

Page Number	Page Title	Page Reference
01-000-TOC	ENGINE, FUEL AND EXHAUST SYSTEM	01-000-TOC
02-000-TOC	AXLES	02-000-TOC
03-000-TOC	STEERING SYSTEM	03-000-TOC
04-000-TOC	DRIVE TRAIN SYSTEM	04-000-TOC
05-000-TOC	COMPRESSED AIR SYSTEM	05-000-TOC
06-000-TOC	HYDRAULIC SYSTEM	06-000-TOC
07-000-TOC	ELECTRICAL SYSTEM	07-000-TOC
08-000-TOC	CAB	08-000-TOC
09-000-TOC	AIR CONDITIONING AND HEATING SYSTEM	09-000-TOC
10-000-TOC	CHASSIS	10-000-TOC
11-000-TOC	WHEELS	11-000-TOC
12-000-TOC	IMPLEMENT LIFT SYSTEM FRONT	12-000-TOC
13-000-TOC	IMPLEMENT LIFT SYSTEM REAR	13-000-TOC
14-000-TOC	FRONT/REAR LOADERS	14-000-TOC
15-000-TOC	ACCESSORIES	15-000-TOC

Page Number	Page Title	Page Reference
01-0001	SPEED CONTROL ENGINE STOP	2010
01-0002	SPEED CONTROL REVERSE DRIVING IMPLEMENT	2020
01-0003	WATER COOLED RADIATOR	2030
01-0004	COOLING SYSTEM CENTRIFUGAL PUMP PIPE	2050
01-0005	FUEL TANK	2070
01-0006	FUEL FILTER FUEL LINES	2075
01-0007	AIR FILTER PICLON	2080
01-0008	AIR FILTER PICO	2090
01-0009	EXHAUST	2100
01-0010	TRACTOMETER SYSTEM	2120
01-0011	COLD STARTING AID	2130
01-0012	CRANKCASE	2170
01-0013	FRONT COVER FLYWHEEL HOUSING	2180
01-0014	CYLINDER HEAD	2190
01-0015	CRANKSHAFT PISTON	2200
01-0016	CAMSHAFT	2210
01-0017	VALVE DRIVE	2220
01-0018	OIL GEAR PUMP OIL FILTER	2230
01-0019	INJECTION PUMP	2240
01-0020	FUEL PUMP	2250
01-0021	INJECTOR VALVE	2260
01-0022	FUEL PRESSURE LINES	2270

FAVORIT 600 (280/00001-99999)
884

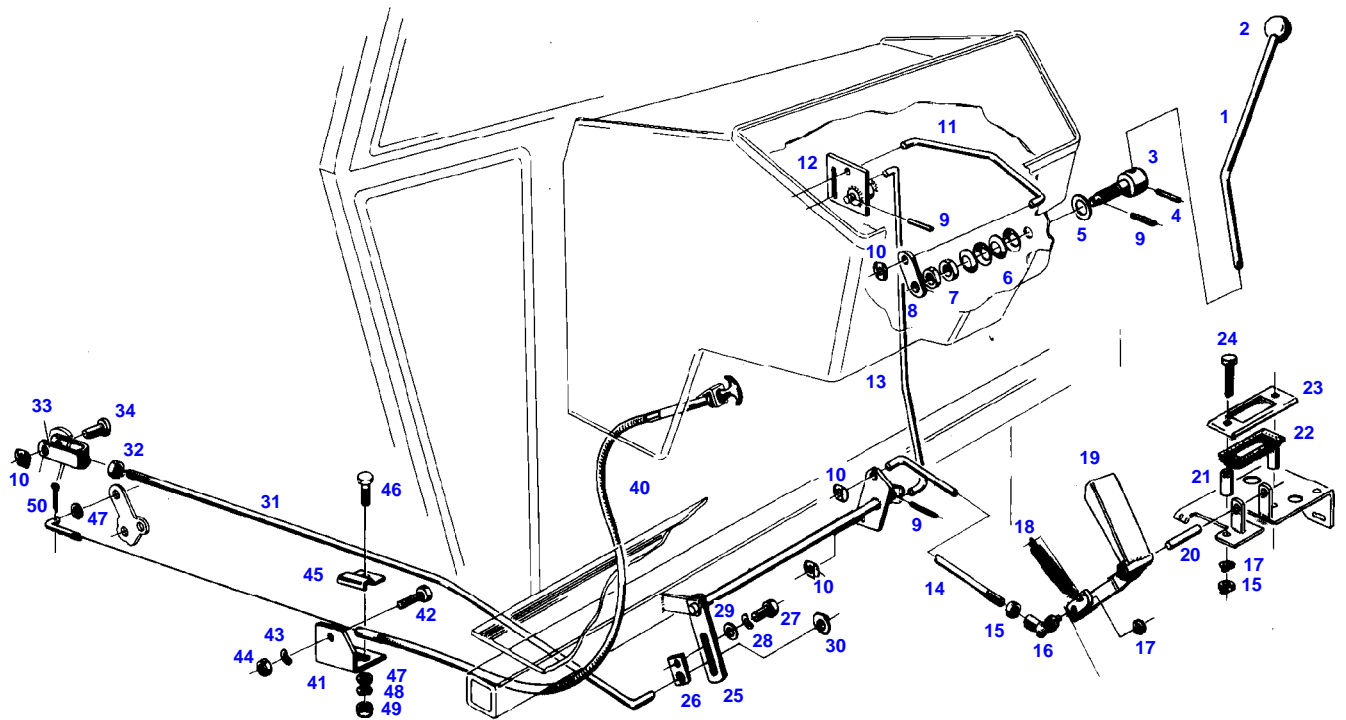

78887

<https://www.ebooklibonline.com>

Hello dear friend!

Thank you very much for reading.

Enter the link into your browser.

The full manual is available for immediate download.

<https://www.ebooklibonline.com>

Item	Part Number	Qty	Description Comments	Technical Specification
ENGINE STOP				
1	72404903	1	LEVER	
2	72393661	1	HANDLE GRIP	
3	72404904	1	BOLT	
4	72375134	1	TENSIONING PIN	ISO8752-4X30-A-ST-OB3 FWN10256
	72428239	2	TENSIONING PIN	ISO8752-2,5X22-OB3
5	72422379	1	FRICION WASHER	
6	72316459	4	DISK SPRING	28X14,2X1,25
7	72372883	2	NUT	DIN 936 M14-17H
8	72404909	1	LEVER	
9	72313803	3	TENSIONING PIN	ISO8752-4X20-A-ST-ZNPHR10F-KOE
10	72311179	5	DUO-CLIP	6 SXN10
11	72404908	1	ROD	
12	72362030	1	REVERSING LEVER	
13	72404907	1	ROD	
14	72404782	1	DRAFT ROD	
15	72313266	3	NUT	DIN 934 M6-8A3L
16	72316303	1	BALL SOCKET	DIN 71805 B10-A3L
			<>	
	72317189	1	SECURING CLIP	DIN71805 S10-A3L
	72313266	1	NUT	DIN 934 M6-8A3L
	72313852	1	BALL PIN	DIN 71803-C10-ST-A3L
17	72315052	3	SPLIT WASHER	FWN 65208-6-A3L
18	72316492	1	PULLING SPRING	
19	72361970	1	PEDAL	
			<>	
	72404789	1	ANGLE	
	72315626	3	HEXAGONAL HEAD BOLT	DIN 933-M6 X 16-8.8-A3L
	72315052	3	SPLIT WASHER	FWN 65208-6-A3L
	72361969	1	BY PASS	
	72313266	3	NUT	DIN 934 M6-8A3L
	72361969	1	BY PASS	
			NOT ILLUSTRATED	
			<>	
	72315626	3	HEXAGONAL HEAD BOLT	DIN 933-M6 X 16-8.8-A3L
	72361970	1	PEDAL	
	72315052	3	SPLIT WASHER	FWN 65208-6-A3L
	72404789	1	ANGLE	
	72313266	3	NUT	DIN 934 M6-8A3L
	72373205	1	PLASTIC RIVET	6
			<-- 280/0425	
			NOT ILLUSTRATED	
	72404789	1	ANGLE	
			<-- 280/0425	
			NOT ILLUSTRATED	
	72315626	1	HEXAGONAL HEAD BOLT	DIN 933-M6 X 16-8.8-A3L
			<-- 280/0425	
			NOT ILLUSTRATED	
	72313266	1	NUT	DIN 934 M6-8A3L
			<-- 280/0425	
			NOT ILLUSTRATED	
	72311787	2	DISC	DIN 125-6,4-ST.A3L
			<-- 280/0425	
			NOT ILLUSTRATED	
	72315052	1	SPLIT WASHER	FWN 65208-6-A3L
			<-- 280/0425	
			NOT ILLUSTRATED	
20	72404783	1	BOLT	
21	72404784	2	SPACER TUBE	
22	72404786	1	SEAL	
23	72404785	1	COVER PLATE	
24	72315637	2	HEXAGONAL HEAD BOLT	DIN 933 M6X45-8.8A3L
25	72362028	1	SHAFT	
			--> 280/0424	

Item	Part Number	Qty	Description Comments	Technical Specification
	72361966	1	SHAFT <-- 280/0425	
26	72404910	1	ADJUSTING PLATE	
27	72315626	1	HEXAGONAL HEAD BOLT	DIN 933-M6 X 16-8.8-A3L
28	72317120	1	SPRING WASHER	DIN 137 B6-MECH.VZK
29	72311787	1	DISC	DIN 125-6,4-ST.A3L
30	72311180	1	DUO-CLIP	8 SXN10
31	72404905	1	ROD	
32	72313268	1	NUT	DIN 934 M8-8A3L
33			NO LONGER AVAILABLE	
34	72372462	1	BOLT	DIN 1436 6H11X22X18-UST36-2A3L
40	72350277	1	STOP CABLE <>	
	72310448	1	BOLT	FWN 64072 6X24 A3L
	72409005	1	ANGLE	
	72311308	1	CLEVIS	DIN 71752 G6X24-A3L
	72343546	1	PULL HANDLE RED NOT ILLUSTRATED	
41	72404902	1	ANGLE	
42	72315653	1	HEXAGONAL HEAD BOLT	DIN 933 M8 X 25-8.8A3L
43	72315053	1	SPLIT WASHER	FWN 65208-8-A3L
44	72313268	1	NUT	DIN 934 M8-8A3L
45			NO LONGER AVAILABLE	
46	72315626	1	HEXAGONAL HEAD BOLT	DIN 933-M6 X 16-8.8-A3L
47	72311787	2	DISC	DIN 125-6,4-ST.A3L
48	72315052	1	SPLIT WASHER	FWN 65208-6-A3L
49	72313266	1	NUT	DIN 934 M6-8A3L
50	72313873	1	COTTER	DIN 94-2X12-ST.A3L

FAVORIT 600 (280/00001-99999)
463

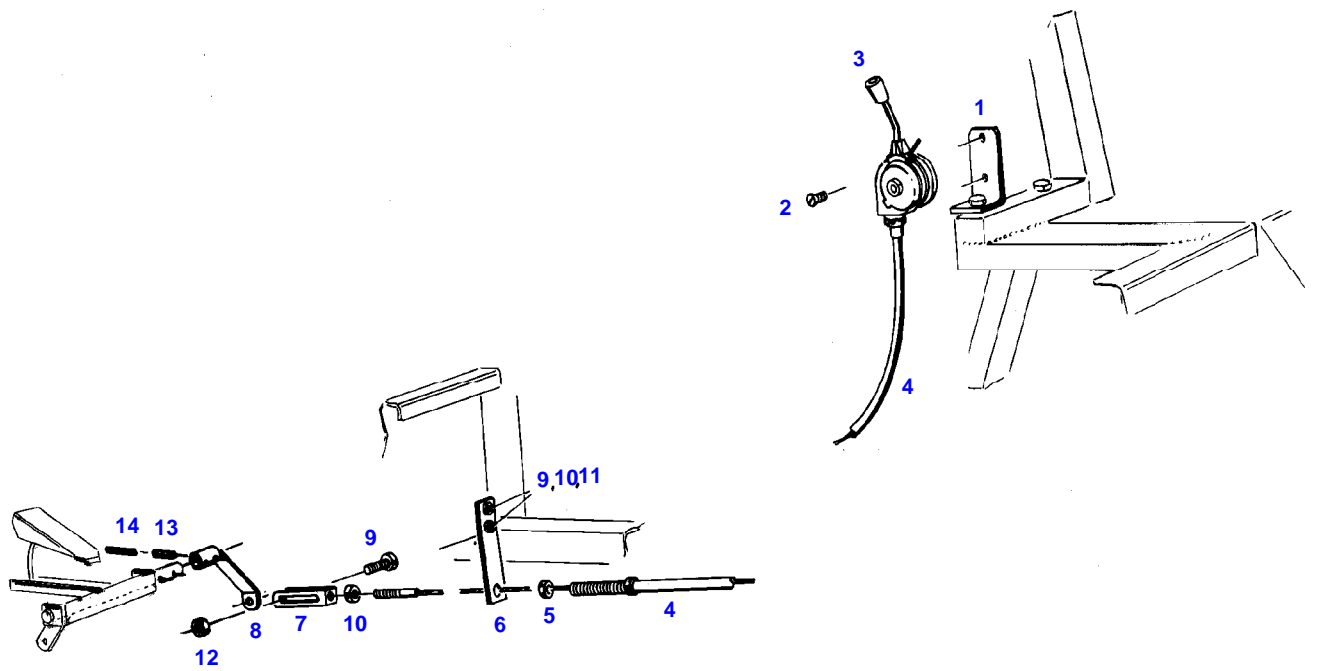

0463

Item	Part Number	Qty	Description Comments	Technical Specification
REVERSE DRIVING IMPLEMENT				
1	72405404	1	RETAINER	
2	72375017	2	COUNTERSUNK CAPSCREW	DIN 7991 M8X12-8.8
3	72332384	1	REGULATOR LEVER	
4	72349753	1	CONTROL CABLE	
5	72372813	1	NUT	DIN 934 M10X1-8A3L
6	72405405	1	RETAINER	
7	72405408	1	FORK	
8	72405407	1	ANGLE --> 280/0424	
	72405406	1	ANGLE <-- 280/0425	
	72315631	2	HEXAGONAL HEAD BOLT --> 280/0424 NOT ILLUSTRATED	DIN 933 M6 X 20-8.8A3L
	72315629	2	HEXAGONAL HEAD BOLT <-- 280/0425 NOT ILLUSTRATED	DIN 933 M6 X 12-8.8A3L
	72313266	2	NUT --> 280/0424 NOT ILLUSTRATED	DIN 934 M6-8A3L
9	72315633	3	HEXAGONAL HEAD BOLT	DIN 933 M6X25-8.8A3L
10	72313266	3	NUT	DIN 934 M6-8A3L
11	72311787	2	DISC	DIN 125-6,4-ST.A3L
12	72313318	1	NUT	DIN6925-M6-8-A3L
13			NOT USED	
14			NOT USED	

FAVORIT 600 (280/00001-99999)
885

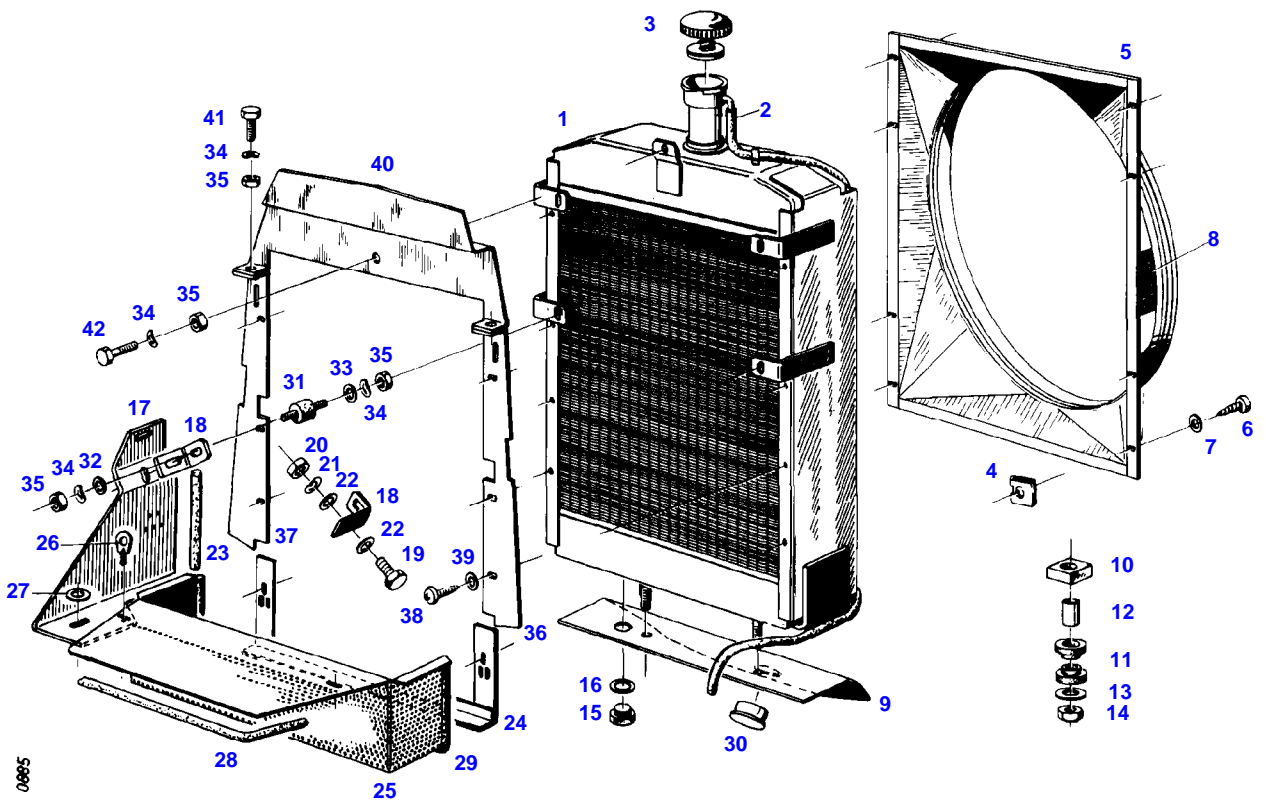

Item	Part Number	Qty	Description Comments	Technical Specification
1	72471948	1	NO LONGER AVAILABLE	
2	72436028	1	HOSE	L=1500FWN65912-10X2-PVC-W-G
3	72478248	1	COLLER LOCKING	
4	72329197	8	SPEED NUT	
5			NO LONGER AVAILABLE	
6	72315819	8	SCREW	DIN7976-ST4,8X13-C-A3L
7	72311818	8	DISC	DIN9021-5,3-140HV-A3L
8	72379109	2	MARKING PLATE	FWN66556-35X68-SCHUTZVORR.N.OE
9			NO LONGER AVAILABLE	
10	72404913	2	DISC	
11	72311639	4	RADIATOR DAMPER	
12	72310742	2	BUSH	
13	72311849	2	DISC	
14	72313327	2	NUT	DIN 980-VM14-8-A3L
15	72315799	1	PLUG	DIN 7604 AM14X1,5-A3L
16	72315094	1	SEALING WASHER	DIN 7603 A14X18-CU
17	72405993	1	RETAINER RIGHT	
	72405991	1	RETAINER LEFT	
18			NO LONGER AVAILABLE	
19	72315650	2	HEXAGONAL HEAD BOLT	DIN 933 M8 X 20-8.8A3L
20	72313268	2	NUT	DIN 934 M8-8A3L
21	72317121	2	SPRING WASHER	DIN 137 B8-MECH.VZK
22	72311788	4	DISC	DIN 125-8,4-ST.A3L
23			NO LONGER AVAILABLE	
24			NO LONGER AVAILABLE	
25			NO LONGER AVAILABLE	
	72405999	1	COVER PLATE NOT ILLUSTRATED	
	72315789	2	SCREW NOT ILLUSTRATED	DIN 7981 ST4,8X9,5-C-H-A3
	72311818	2	DISC NOT ILLUSTRATED	DIN9021-5,3-140HV-A3L
26	72334276	1	CATCH	
27	72311793	2	DISC	DIN 125-17-ST.A3L
28	72451141	1	PROTECTIVE STRIP 1X 690 MM CUT TO LENGTH	L=800 FWN 63040
29	72451141	1	PROTECTIVE STRIP 1X 745 MM CUT TO LENGTH	L=800 FWN 63040
30	72375084	1	LOCKING PLUG	SW-F35
31	72310623	2	BUFFER	
32	72311787	2	DISC	DIN 125-6,4-ST.A3L
33	72311822	2	DISC	DIN9021-6,4-140HV-A3L
34	72317120	7	SPRING WASHER	DIN 137 B6-MECH.VZK
35	72313266	7	NUT	DIN 934 M6-8A3L
36	72404914	1	BARRIER WALL LEFT	
37	72404915	1	BARRIER WALL RIGHT	
38	72315781	6	SCREW	DIN 7981 ST3,5X9,5-C-H-A3
39	72311817	6	DISC	DIN9021-4,3-140HV-A3L
40	72404928	1	SPLASH PANEL	
41	72315629	2	HEXAGONAL HEAD BOLT	DIN 933 M6 X 12-8.8A3L
42	72315631	1	HEXAGONAL HEAD BOLT	DIN 933 M6 X 20-8.8A3L

FAVORIT 600 (280/00001-99999)
1018

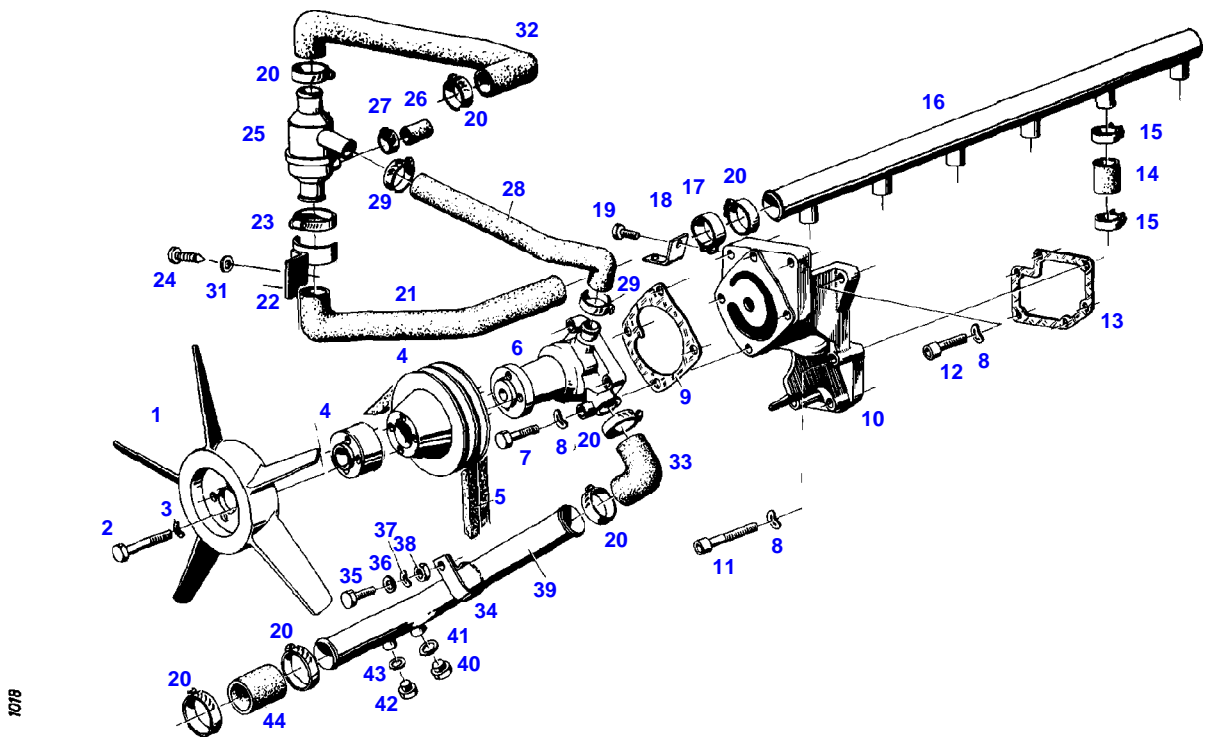

Item	Part Number	Qty	Description Comments	Technical Specification
			CENTRIFUGAL PUMP PIPE	
1	72331755	1	FAN <>	
	72394835	4	DISC	
	72331543	1	FAN TROPICAL VERSION	
2	72315673	4	HEXAGONAL HEAD BOLT	DIN 933 M8X75-8.8A3L
3	72317121	4	SPRING WASHER	DIN 137 B8-MECH.VZK
4	72340154	1	V BELT SHEAVE	
	72409031	1	INTERMEDIATE RING NOT ILLUSTRATED	
5			SEE ALTERNATOR ASSY	
6	72424160	1	CENTRIFUGAL PUMP	
	72340137	1	FACE SEAL NOT ILLUSTRATED	
	72340139	1	COUNTER RING NOT ILLUSTRATED	
7	72315659	4	HEXAGONAL HEAD BOLT	DIN 933 M8X35-8.8
8	72315053	10	SPLIT WASHER	FWN 65208-8-A3L
9	72328678	1	SEAL	
10	72340134	1	INTERMEDIATE PIECE	
11	72315484	4	SOCKET HEAD BOLT	DIN 912 M8X65-10.9A3L
12	72315476	2	SOCKET HEAD BOLT	DIN 912 M8X30-10.9
13			SEE CRANKCASE	
14	72450415	1	HOSE 1X 30MM CUT TO LENGTH	L=900 DIN73411-22X3,5 R
15	72311167	12	HOSE CLIP	
16	72341138	1	PRESSURE LINE	
17	72337051	2	PIPE CLAMP	
18	72326283	1	GUSSET PLATE	
19	72315630	2	HEXAGONAL HEAD BOLT	DIN 933 M6X18-8.8A3L
20	72311162	8	HOSE CLIP	
21	72404920	1	RUBBER ARCH	
22	72362035	1	RETAINER	
23	72311171	1	HOSE CLIP	
24	72315789	2	SCREW	DIN 7981 ST4,8X9,5-C-H-A3
25	72380194	1	THERMOSTAT	
26	72404925	1	CAP NOT NEEDED WITH HEATING	
27	72311167	1	HOSE CLIP NOT NEEDED WITH HEATING	
28	72404921	1	RUBBER ARCH	
29	72311167	2	HOSE CLIP	
31	72311787	2	DISC	DIN 125-6,4-ST.A3L
32	72405866	1	RUBBER ARCH	
33	72399873	1	RUBBER ARCH	
34	72394567	1	FASTENING COLLAR	
35	72315631	1	HEXAGONAL HEAD BOLT	DIN 933 M6 X 20-8.8A3L
36	72311822	1	DISC	DIN9021-6,4-140HV-A3L
37	72317120	1	SPRING WASHER	DIN 137 B6-MECH.VZK
38	72313266	1	NUT	DIN 934 M6-8A3L
39			NO LONGER AVAILABLE	
40	72315802	1	SCREW --> 280/1498 WITHOUT HEATING	DIN 7604 AM22X1,5-ST
41	72315101	1	SEALING WASHER --> 280/1498 WITHOUT HEATING	DIN 7603 A22X27-CU
42	72315799	1	PLUG	DIN 7604 AM14X1,5-A3L

Fendt

FAVORIT 600 (280/00001-99999)

F280000

COOLING SYSTEM

Page01-0004

Item	Part Number	Qty	Description Comments	Technical Specification
43	72315094	1	SEALING WASHER	DIN 7603 A14X18-CU
44	72450416	1	HOSE 1X 60MM CUT TO LENGTH	L=120 DIN73411-35X

FAVORIT 600 (280/00001-99999)
6084

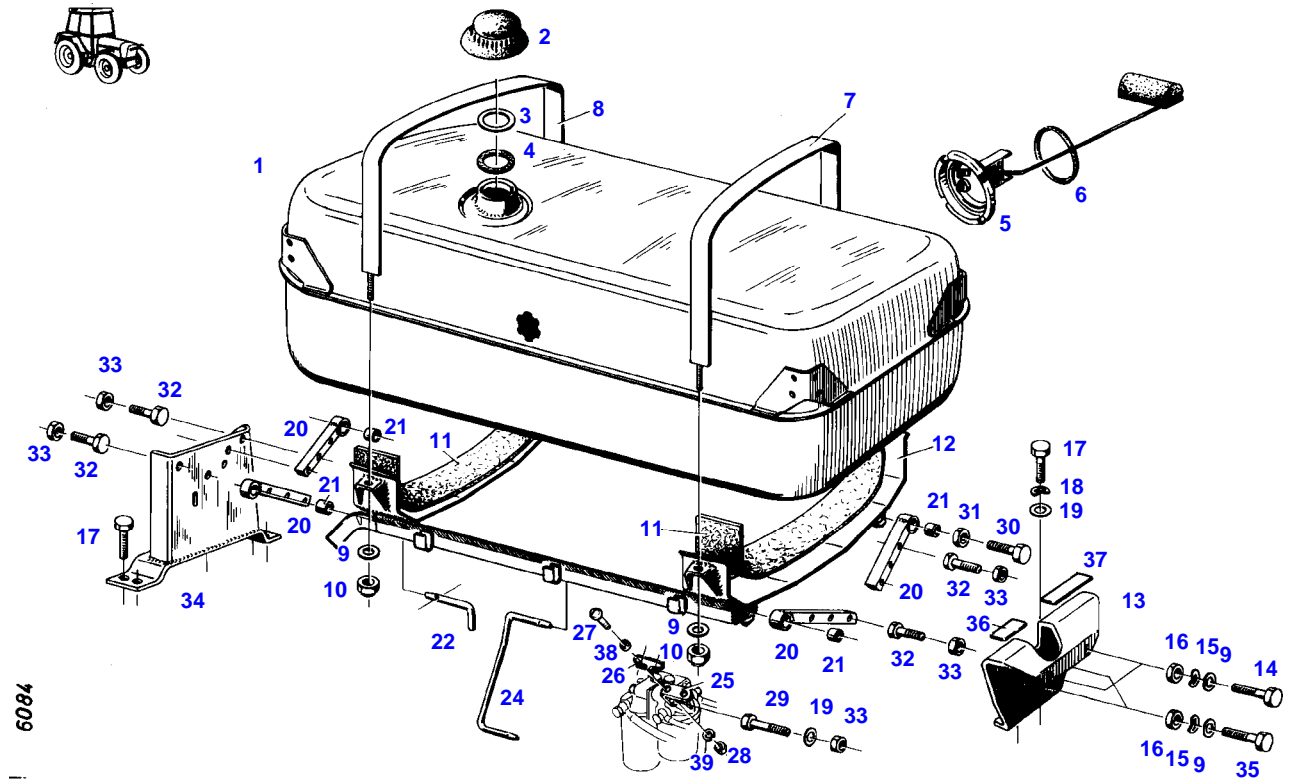

6084

Item	Part Number	Qty	Description Comments	Technical Specification
1	72364691	1	FUEL TANK <>	
	72315101	1	SEALING WASHER	DIN 7603 A22X27-CU
	72315802	1	SCREW	DIN 7604 AM22X1,5-ST
	72315104	1	SEALING WASHER	DIN 7603 A26X31-CU
	72409020	1	REDUCER	
2	72380143	1	FUEL CAP ><3-4 <>	M.BELUEF
	72394572	1	PLASTIC CAP	
	72394572	1	PLASTIC CAP	
3	72330725	1	SEAL BLAU	
4	72330725	1	SEAL BLAU	
	72312304	1	RUBBER SEAL KOEHLER	
5	72613427	1	FUEL LEVEL SENSOR ><5+6	
6	72315169	1	SEALING WASHER	
7	72362041	1	BAND CLAMP	
8	72362042	1	BAND CLAMP	
9	72311788	8	DISC	DIN 125-8,4-ST.A3L
10	72313320	4	NUT	DIN6925-M8-8-A3L
11	72404934	2	FELT TAPE	
12	72364628	1	FRAME	
13	72409303	1	CONSOLE	
14	72315659	2	HEXAGONAL HEAD BOLT	DIN 933 M8X35-8.8
15	72315053	4	SPLIT WASHER	FWN 65208-8-A3L
16	72313268	4	NUT	DIN 934 M8-8A3L
17	72315678	7	HEXAGONAL HEAD BOLT	DIN 933 M10X20-8.8
18	72315054	2	SPLIT WASHER	FWN 65208-10-A3L
19	72311789	3	DISC	DIN 125-10,5-ST.A3L
20	72404942	4	SUPPORT ARM	
21	72310644	4	RUBBER BUSHING	
22	72397322	1	BEARING PIN	
	72311183	2	HAIR COTTER PIN NOT ILLUSTRATED	DIN 11024-4-A3L
24	72404936	1	BEARING PIN	
25	72404938	1	ANGLE	
26	72399331	1	RETAINER	
27	72315619	2	HEXAGONAL HEAD BOLT	DIN 933 M5X16-8.8A3L
28	72313264	2	NUT	DIN 934 M5-8A3L
29	72315689	1	HEXAGONAL HEAD BOLT	DIN 933 M10X35-8.8A3L
30	72374215	2	HEXAGONAL HEAD BOLT	DIN 931 M12X65-8.8
31	72313325	2	NUT	DIN 980-VM12-8-A3L
32	72315693	8	HEXAGONAL HEAD BOLT	DIN 933 M10X45-8.8A3L
33	72313272	9	NUT	DIN 934 M10-8A3L
34	72364688	1	CONSOLE	
35	72315663	3	HEXAGONAL HEAD BOLT	DIN 933 M8X40-8.8A3L
36	72404939	1	BAND 1X 77MM	
37	72404943	1	BAND 1X 67MM	
38	72311818	2	DISC	DIN9021-5,3-140HV-A3L
39	72315051	2	SPLIT WASHER	FWN 65208-5-A3L

FAVORIT 600 (280/00001-99999)
39732

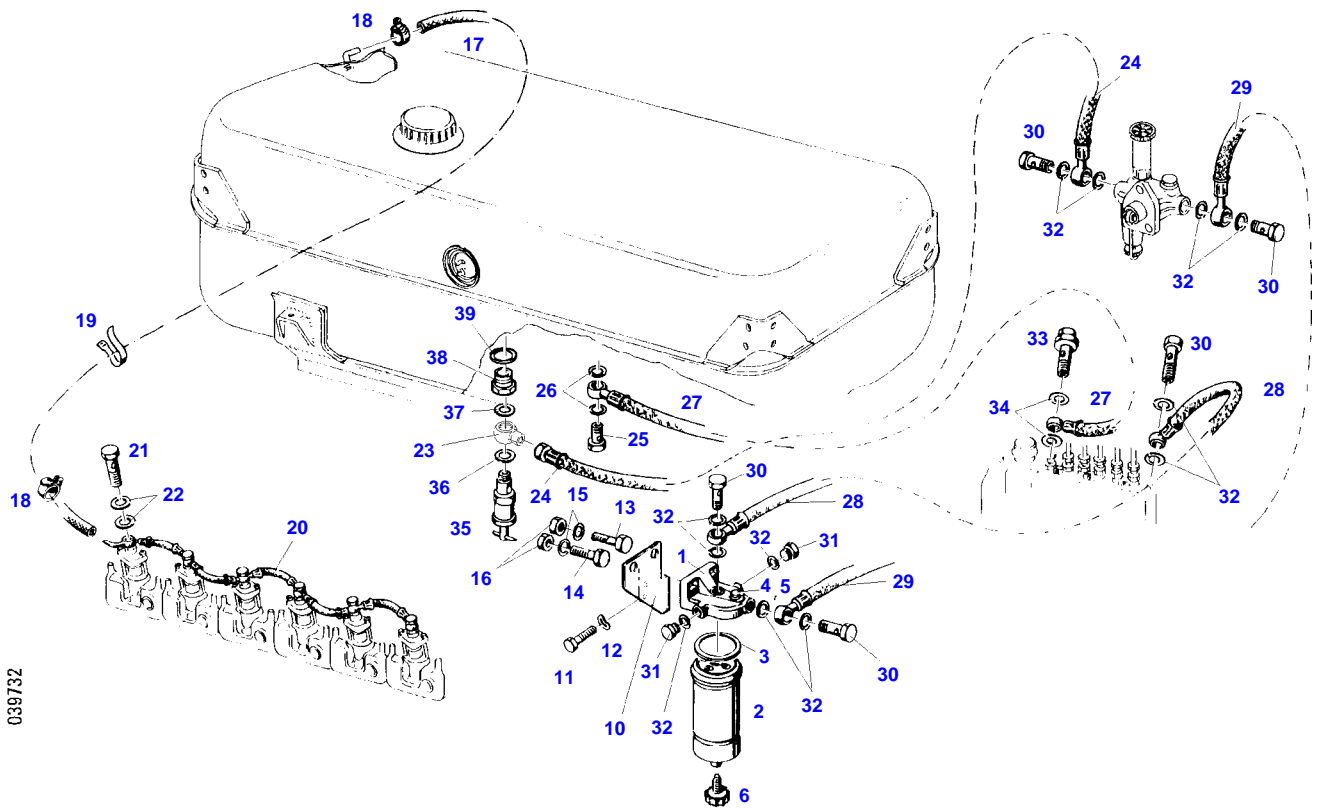

Item	Part Number	Qty	Description Comments	Technical Specification
FUEL LINES				
1	72350307	1	FUEL FILTER ><1-3	
2	72416928	1	FILTER BOX ><2+3	
3	72314995	1	RUBBER RING	
4	72323290	1	BLEED SCREW	
5	72315084	1	SEALING WASHER	DIN 7603 A6X10-CU
6	72330827	1	DRAIN SCREW	
10	72404935	1	RETAINING BRACKET	
11	72315642	2	HEXAGONAL HEAD BOLT	DIN 933 M8 X 16-8.8A3L
12	72315053	2	SPLIT WASHER	FWN 65208-8-A3L
13	72315685	1	HEXAGONAL HEAD BOLT	DIN 933 M10X30-8.8A3L
14			SEE FUEL TANK	
15	72311789	2	DISC	DIN 125-10,5-ST.A3L
16	72313272	2	NUT	DIN 934 M10-8A3L
17	72435830	1	PRESSURE HOSE 1390 MM CUT TO LENGTH	L=2100
18	72438345	2	HOSE CLIP	
19	72316916	3	CABLE STRAP	FWN 66650 B175X4-SW
20	72340112	1	LEAKAGE OIL LINE	
21	72315809	6	BANJO BOLT	DIN 7643-4-5-A3L
22	72315086	12	SEALING WASHER	DIN 7603 A8X11,5-CU
23	72377538	1	BANJO UNION	
24	72364540	1	FUEL LINE	
25	72315807	1	BANJO BOLT	DIN 7643-8-3-A3L
26	72315090	2	SEALING WASHER	DIN 7603 A12X15,5-CU
27	72364689	1	FUEL LINE	
28	72362049	1	FUEL LINE	
29	72362048	1	FUEL LINE	
30	72315808	5	BANJO BOLT	DIN 7643-10-3-A3L
31	72315799	2	PLUG	DIN 7604 AM14X1,5-A3L
32	72315094	12	SEALING WASHER	DIN 7603 A14X18-CU
33	72317103	1	BLEED AND DRAIN VALVE	
34	72315095	2	SEALING WASHER	DIN 7603 A14X20-CU
35	72380161	1	FUEL SHUT-OFF VALVE	
36	72315099	1	SEALING WASHER	DIN 7603 A18X22-CU
37	72315098	1	SEALING WASHER	DIN 7603 A16X22-CU
38	72409020	1	REDUCER	
39	72315104	1	SEALING WASHER	DIN 7603 A26X31-CU
40	72393682	1	MARKING PLATE ARABIAN-ENGLISH NOT ILLUSTRATED	

FAVORIT 600 (280/00001-99999)
340

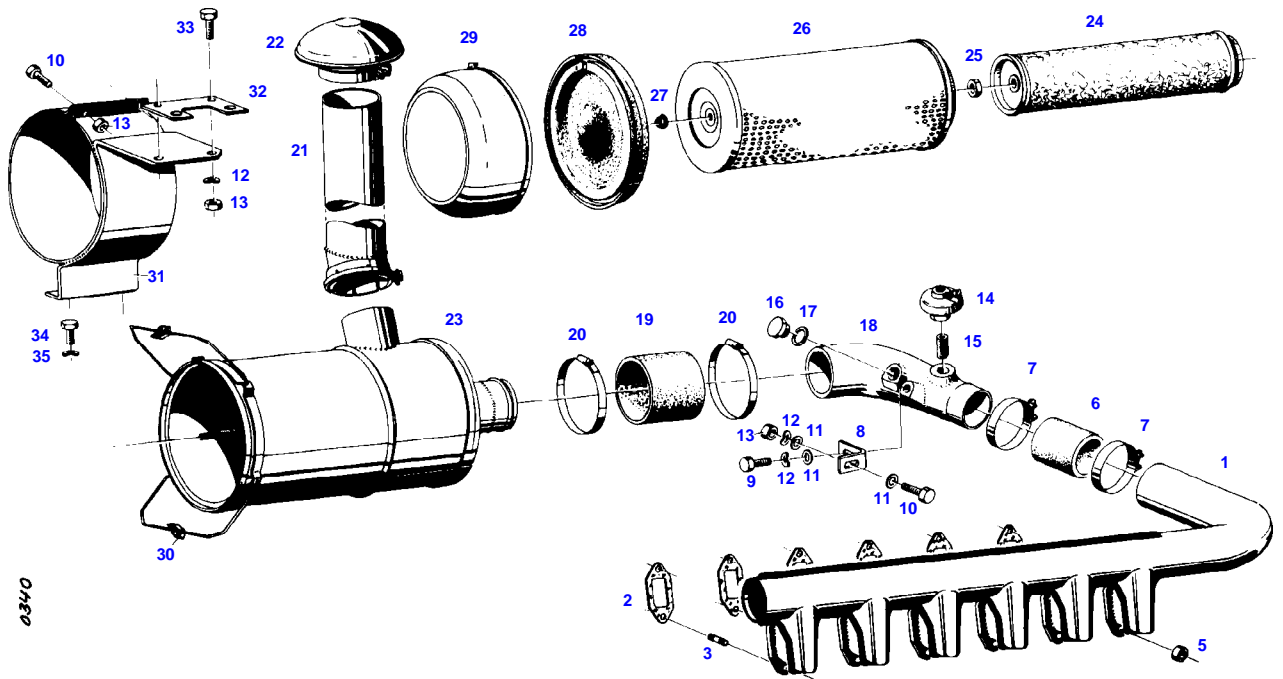

0340

Item	Part Number	Qty	Description Comments	Technical Specification
PICLON				
1	72340719	1	INTAKE MANIFOLD	
	72373975	1	SCREW FOR TEMPERATURE RANGE 2 TRACTORS WITHOUT COLD START DEVICE NOT ILLUSTRATED	DIN 910 M20X1,5-ST
	72376031	1	SEALING WASHER FOR TEMPERATURE RANGE 2 TRACTORS WITHOUT COLD START DEVICE NOT ILLUSTRATED	DIN 7603 A20X24-CU
2	72332145	6	MOLDED SEAL	
3	72373922	12	STUD BOLT	DIN 835-M10X25-8.8
5	72313272	12	NUT	DIN 934 M10-8A3L
6	72450420	1	HOSE 1X 80MM CUT TO LENGTH	L=120 DIN73411-70X5 R
7	72373528	2	HOSE CLIP	
8	72404947	1	ANGLE	
9	72315646	1	HEXAGONAL HEAD BOLT	DIN 933 M8X18-8.8A3L
10	72315653	3	HEXAGONAL HEAD BOLT	DIN 933 M8 X 25-8.8A3L
11	72311788	3	DISC	DIN 125-8,4-ST.A3L
12	72315053	4	SPLIT WASHER	FWN 65208-8-A3L
13	72313268	5	NUT	DIN 934 M8-8A3L
14	72316876	1	MAINTENANCE SWITCH <>	
	72379175	0	WIRE	B1,5 DIN72551/6.51 SCHWARZ
	72380356	1	CABLE LUG	
	72314686	1	PLUG IN SLEEVE	
15	72339032	1	THREADED SOCKET	
16	72315442	1	PLUG	DIN 908 M22X1,5-ST
17	72315101	1	SEALING WASHER	DIN 7603 A22X27-CU
18	72404946	1	INTAKE MANIFOLD	
19	72395094	1	RUBBER PIECE	
20	72311173	2	HOSE CLIP	
21	72340120	1	INTAKE MANIFOLD	
22	72332141	1	RAIN CAP	
23	72349691	1	AIR FILTER ><23-30	
	72340122	1	DIFFUSER NOT ILLUSTRATED	
24	72332148	1	SAFETY CARTRIDGE	
25	72313299	1	NUT	DIN 936-M16X1,5-17H
26	72332142	1	MICRO-TOP CARTRIDGE	
27	72339030	1	COLLAR NUT	
28	72332146	1	INTERMEDIATE PLATE	
29	72340121	1	CUP	
30	72326152	2	TENSIONING DEVICE	
	72340124	2	HOLDER NOT ILLUSTRATED	
	72340123	2	RETAINER NOT ILLUSTRATED	
31	72364630	1	BAND CLAMP <>	
	72409006	1	RETAINING SHEET METAL	
32	72404945	1	RETAINING SHEET METAL	
33	72315642	2	HEXAGONAL HEAD BOLT	DIN 933 M8 X 16-8.8A3L
34	72315645	2	HEXAGONAL HEAD BOLT	DIN 933 M8 X 12-8.8A3L
35	72317121	2	SPRING WASHER	DIN 137 B8-MECH.VZK
36	72404957	1	ABSORPTION INDICATOR (1,3) NOT ILLUSTRATED	

FAVORIT 600 (280/00001-99999)
882

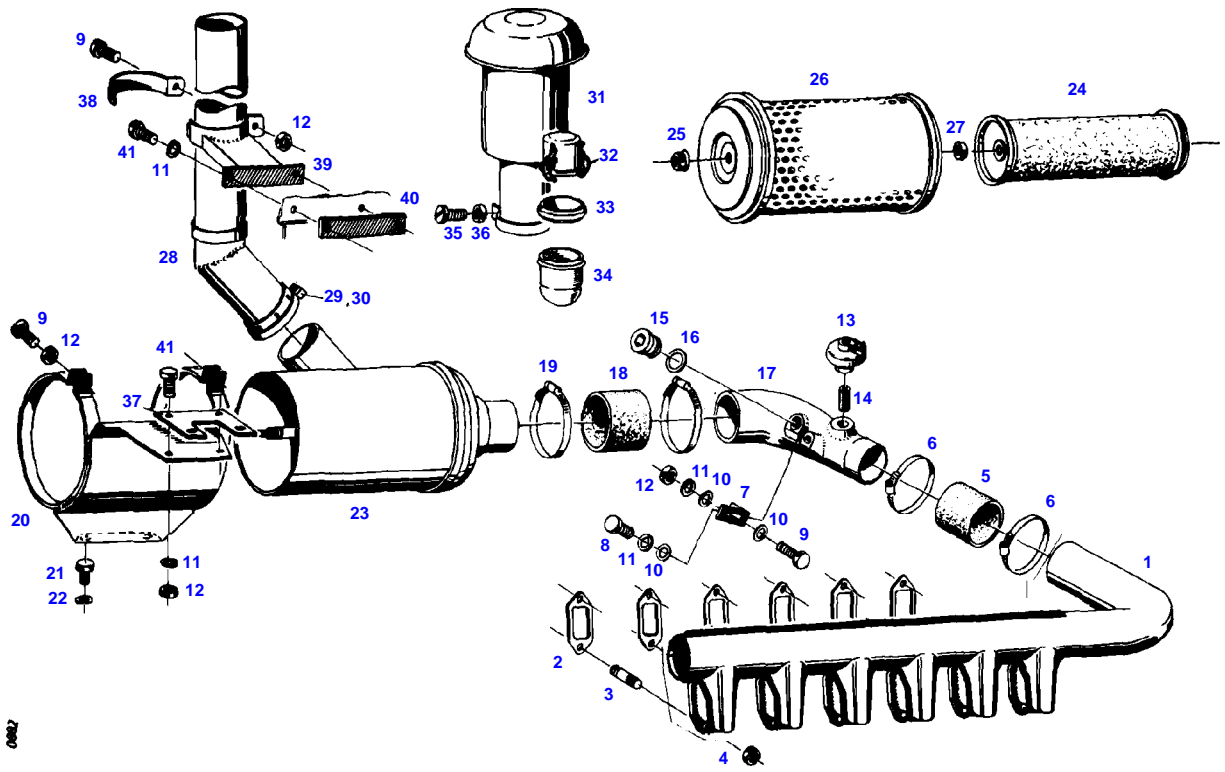

0002

Item	Part Number	Qty	Description Comments	Technical Specification
PICO				
1	72340719	1	INTAKE MANIFOLD	
	72373975	1	SCREW FOR TEMPERATURE RANGE 2 TRACTORS WITHOUT COLD START DEVICE NOT ILLUSTRATED	DIN 910 M20X1,5-ST
	72376031	1	SEALING WASHER FOR TEMPERATURE RANGE 2 TRACTORS WITHOUT COLD START DEVICE NOT ILLUSTRATED	DIN 7603 A20X24-CU
2	72332145	6	MOLDED SEAL	
3	72373922	12	STUD BOLT	DIN 835-M10X25-8.8
4	72313272	12	NUT	DIN 934 M10-8A3L
5	72450420	1	HOSE 1X 80MM CUT TO LENGTH	L=120 DIN73411-70X5 R
6	72373528	2	HOSE CLIP	
7	72404947	1	ANGLE	
8	72315646	1	HEXAGONAL HEAD BOLT	DIN 933 M8X18-8.8A3L
9	72315653	4	HEXAGONAL HEAD BOLT	DIN 933 M8 X 25-8.8A3L
10	72311788	3	DISC	DIN 125-8,4-ST.A3L
11	72315053	6	SPLIT WASHER	FWN 65208-8-A3L
12	72313268	6	NUT	DIN 934 M8-8A3L
13	72316876	1	MAINTENANCE SWITCH <>	
	72314686	1	PLUG IN SLEEVE	
	72380356	1	CABLE LUG	
	72379175	0	WIRE	B1,5 DIN72551/6.51 SCHWARZ
14	72339032	1	THREADED SOCKET	
15	72315442	1	PLUG	DIN 908 M22X1,5-ST
16	72315101	1	SEALING WASHER	DIN 7603 A22X27-CU
17	72404946	1	INTAKE MANIFOLD	
18	72395094	1	RUBBER PIECE	
19	72311173	2	HOSE CLIP	
20	72364631	1	RETAINER <>	
	72409006	1	RETAINING SHEET METAL	
21	72315645	2	HEXAGONAL HEAD BOLT	DIN 933 M8 X 12-8.8A3L
22	72317121	2	SPRING WASHER	DIN 137 B8-MECH.VZK
23	72349678	1	AIR FILTER >>24-27	
24	72339772	1	SAFETY CARTRIDGE	
25	72313243	1	COLLAR NUT	
26	72339771	1	MICRO-TOP CARTRIDGE	
27	72313299	1	NUT	DIN 936-M16X1,5-17H
28	72349681	1	INTAKE MANIFOLD >>29,30 <>	
	72349682	1	CYCLONE AIR CLEANER	
29			NO LONGER AVAILABLE	
30	72372783	1	SQUARE NUT	DIN 557 M6-5 A3L
31	72349680	1	CYCLONE AIR CLEANER >>32-36	
32	72321921	2	CATCH	
33	72330736	1	FUNNEL	
34	72320204	1	CONTAINER	
35	72315685	1	HEXAGONAL HEAD BOLT	DIN 933 M10X30-8.8A3L
36	72313272	1	NUT	DIN 934 M10-8A3L
37	72404945	1	RETAINING SHEET METAL	
38	72404790	1	CLAMP	
39	72361972	1	RETAINER	
40	72409381	1	PLATE LINK	

Fendt

FAVORIT 600 (280/00001-99999)

F280000

AIR FILTER

Page01-0008

Item	Part Number	Qty	Description Comments	Technical Specification
41	72315642	4	HEXAGONAL HEAD BOLT	DIN 933 M8 X 16-8.8A3L
42	72404957	1	ABSORPTION INDICATOR NOT ILLUSTRATED	

FAVORIT 600 (280/00001-99999)
1034

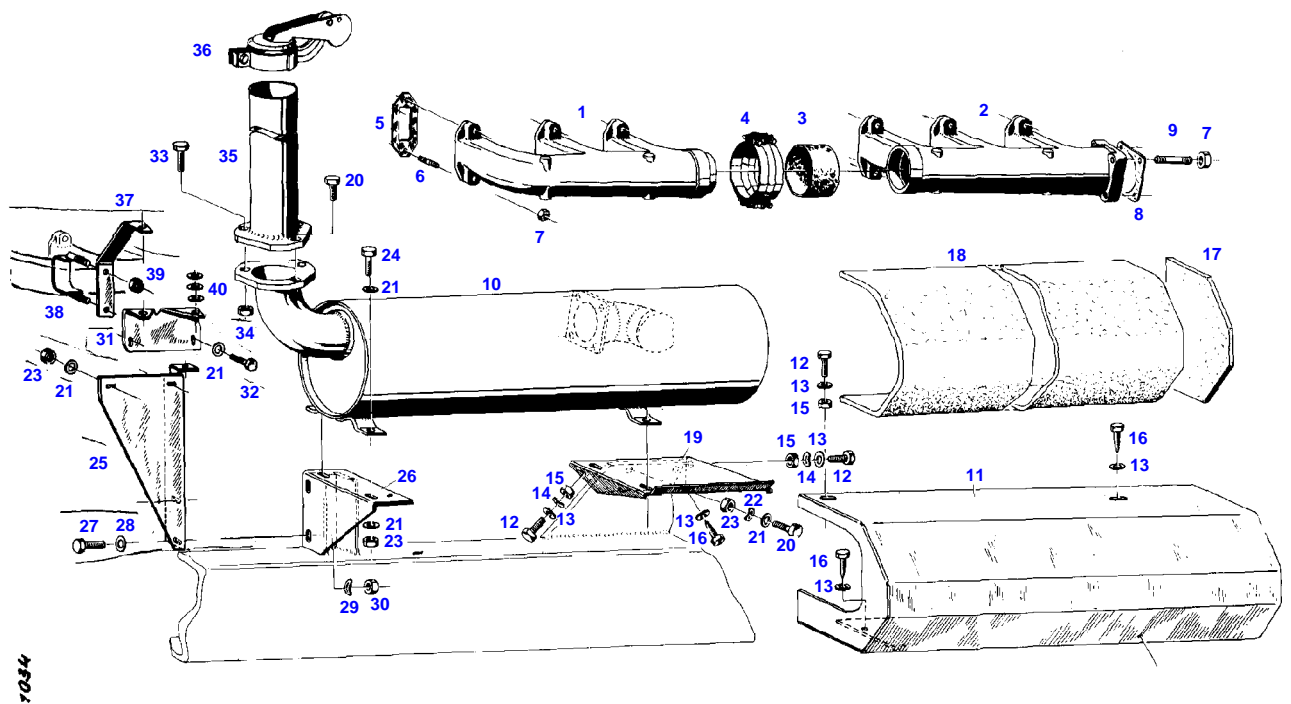



Suggest:

For more complete manuals. Please go to the home page.

<https://www.ebooklibonline.com>

If the above button click is invalid. Please download this document first, and then click the above link to download the complete manual.

Thank you so much for reading

Item	Part Number	Qty	Description Comments	Technical Specification
1	72331546	1	EXHAUST HALF	
2	72340166	1	EXHAUST HALF	
3	72331548	1	ASBESTOS-RING	
4	72331550	1	CRIMPED CLIP	
5	72332145	6	MOLDED SEAL	
6	72374647	12	STUD BOLT	DIN 939-M10X40-8.8
7	72373015	16	NUT	DIN70615-M10-8-A3B
8	72331323	1	SQUARE SEAL	
9	72374644	4	STUD BOLT	DIN 939 M10X25-10.9
10	72362053	1	MUFFLER	
11	72364700	1	TRIM PANEL	
12	72315629	5	HEXAGONAL HEAD BOLT	DIN 933 M6 X 12-8.8A3L
13	72311822	9	DISC	DIN9021-6,4-140HV-A3L
14	72315052	5	SPLIT WASHER	FWN 65208-6-A3L
15	72313266	4	NUT	DIN 934 M6-8A3L
16	72315820	3	SCREW	DIN7976-ST6,3X13-C-A3L
17	72404951	1	INSULATING PLATE	
18	72404952	1	INSULATING PLATE	
19	72404950	1	CONSOLE	
20	72315657	2	HEXAGONAL HEAD BOLT	DIN 933 M8 X 30-8.8A3L
	72315660	1	HEXAGONAL HEAD BOLT	DIN 933 M8X35-8.8A3L
21	72311788	14	DISC	DIN 125-8,4-ST.A3L
22	72315053	4	SPLIT WASHER	FWN 65208-8-A3L
23	72313268	8	NUT	DIN 934 M8-8A3L
24	72315642	4	HEXAGONAL HEAD BOLT	DIN 933 M8 X 16-8.8A3L
25	72406004	1	BRACKET	
26	72404949	1	RETAINING BRACKET	
27	72315685	2	HEXAGONAL HEAD BOLT	DIN 933 M10X30-8.8A3L
28	72311789	2	DISC	DIN 125-10,5-ST.A3L
29	72315054	2	SPLIT WASHER	FWN 65208-10-A3L
30	72313272	2	NUT	DIN 934 M10-8A3L
31	72404948	1	RETAINING BRACKET	
32	72315653	2	HEXAGONAL HEAD BOLT	DIN 933 M8 X 25-8.8A3L
33	72315665	2	HEXAGONAL HEAD BOLT	DIN 933 M8X45-8.8A3L
34	72313269	3	NUT	DIN 934 M8-8C2A
35	72362056	1	EXHAUST PIPE	
	72409384	1	SEAL	
			NOT ILLUSTRATED	
36	72340125	1	EXHAUST WEATHER CAP	
37			NO LONGER AVAILABLE	
38	72356507	1	BAND CLAMP	
39	72313320	2	NUT	DIN6925-M8-8-A3L
40	72311789	3	DISC	DIN 125-10,5-ST.A3L

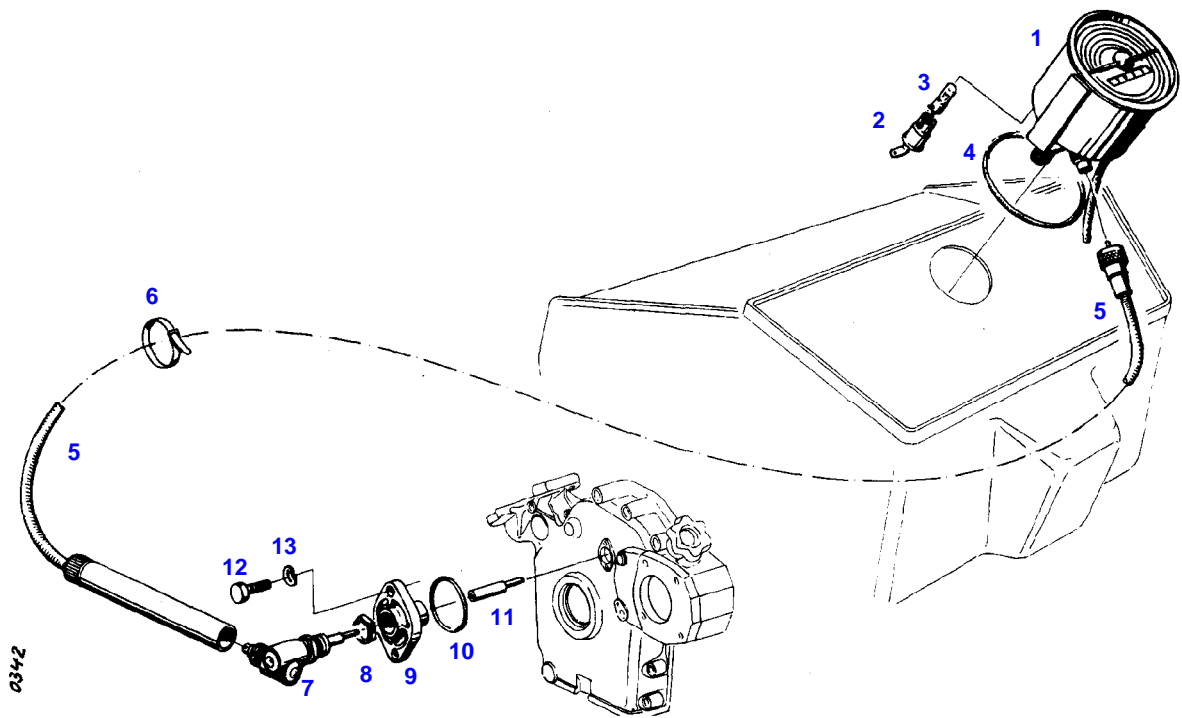

<https://www.ebooklibonline.com>

Hello dear friend!

Thank you very much for reading.

Enter the link into your browser.

The full manual is available for immediate download.

<https://www.ebooklibonline.com>