

Page Number	Page Title	Page Reference
01-000-TOC	ENGINE, FUEL AND EXHAUST SYSTEM	01-000-TOC
02-000-TOC	AXLES	02-000-TOC
03-000-TOC	STEERING SYSTEM	03-000-TOC
04-000-TOC	DRIVE TRAIN SYSTEM	04-000-TOC
05-000-TOC	COMPRESSED AIR SYSTEM	05-000-TOC
06-000-TOC	HYDRAULIC SYSTEM	06-000-TOC
07-000-TOC	ELECTRICAL SYSTEM	07-000-TOC
08-000-TOC	CAB	08-000-TOC
09-000-TOC	AIR CONDITIONING AND HEATING SYSTEM	09-000-TOC
10-000-TOC	CHASSIS	10-000-TOC
11-000-TOC	WHEELS	11-000-TOC
12-000-TOC	IMPLEMENT LIFT SYSTEM FRONT	12-000-TOC
13-000-TOC	IMPLEMENT LIFT SYSTEM REAR	13-000-TOC
14-000-TOC	FRONT/REAR LOADERS	14-000-TOC
15-000-TOC	ACCESSORIES	15-000-TOC

FAVORIT 511 (511/00101-99999)
12422

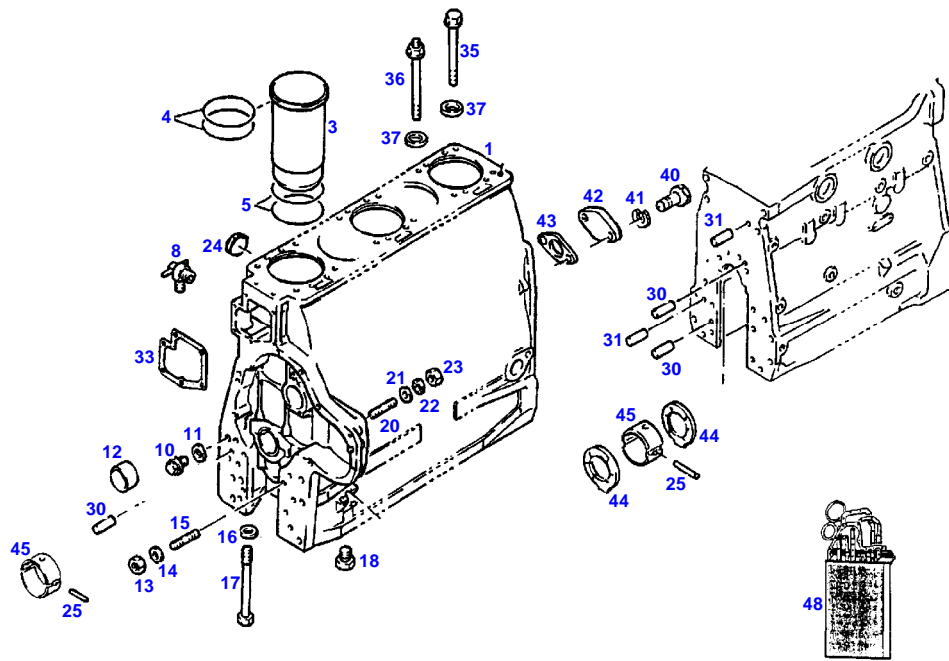

12422

Item	Part Number	Qty	Description Comments	Technical Specification
	72431121	1	DIESEL ENGINE <-- 511/0101 --> 511/0300 <-- 511/1001 --> 511/3000 F511	
	72431122	1	DIESEL ENGINE <-- 511/0301 --> 511/0400 <-- 511/3001 F511	
1	72342950	1	CRANKCASE ><3-24	
3	72425044	6	CYLINDER LINER	
	72416175	6	CYLINDER LINER OVERLAP 0,05 MM	
	72416176	6	CYLINDER LINER OVERLAP 0,1 MM	
4	72329541	12	SEAL	
	72431774	1	REPAIR KIT	
5	72343893	12	SEAL	
	72431774	1	REPAIR KIT	
8	72378063	1	RELIEF VALVE	DIN71401-CM14X1,5KEG
10	72315797	1	PLUG SCREW	DIN 7604 AM10X1-ST A3L
11	72315088	1	SEALING WASHER	DIN 7603 A10X13,5-CU
12	72329540	1	BUSH	
13	72340921	1	MIDGRIP NUT	
14	72340920	1	DISC	
15	72374623	1	STUD BOLT	DIN 939-M8X25-8.8
16	72324592	14	DISC	
17	72327081	14	HEXAGONAL HEAD BOLT	
18	72337035	1	HEXAGONAL HEAD BOLT	
20	72313772	3	STUD BOLT	DIN 939 M8X30-8.8
21	72321257	3	DISC	
22	72315053	3	SPLIT WASHER	FWN 65208-8-A3L
23	72313268	3	NUT	DIN 934 M8-8A3L
24	72377226	5	COVER	DIN 443-50
25	72375130	7	TENSIONING PIN	ISO8752-4X8-A-ST-ZNPH
30	72313859	4	CYLINDER PIN	DIN 7-8M6X18-ST50K
31	72375324	2	CYLINDER PIN	DIN 7-10M6X28-ST50K
33	72327042	1	MOLDED SEAL	
35	72333013	20	SOCKET HEAD BOLT	
36	72333014	4	HEXAGONAL HEAD BOLT	
37	72324592	24	DISC	
40	72315650	2	HEXAGONAL HEAD BOLT	DIN 933 M8 X 20-8.8A3L
41	72315053	2	SPLIT WASHER	FWN 65208-8-A3L
42	72343896	1	COVER	
43	72333001	1	SEAL	
44	72343910	2	THRUST RING 70,00 MM	
	72343911	2	THRUST RING 69,79 MM	
	72343912	2	THRUST RING 69,54 MM	
	72343913	2	THRUST RING 69,04 MM	
45	72341078	7	MAIN BEARING 70,00 MM	
	72341079	7	MAIN BEARING 69,79 MM	
	72341080	7	MAIN BEARING 69,54 MM	
	72341081	7	MAIN BEARING 69,29 MM	
	72341082	7	MAIN BEARING 69,04 MM	

<https://www.ebooklibonline.com>

Hello dear friend!

Thank you very much for reading.

Enter the link into your browser.

The full manual is available for immediate download.

<https://www.ebooklibonline.com>

Fendt

FAVORIT 511 (511/00101-99999)

F511000

CRANKCASE

Page01-0002

Item	Part Number	Qty	Description Comments	Technical Specification
48	72342951	1	SEAL KIT D 226 B-6	

FAVORIT 511 (511/00101-99999)
8328

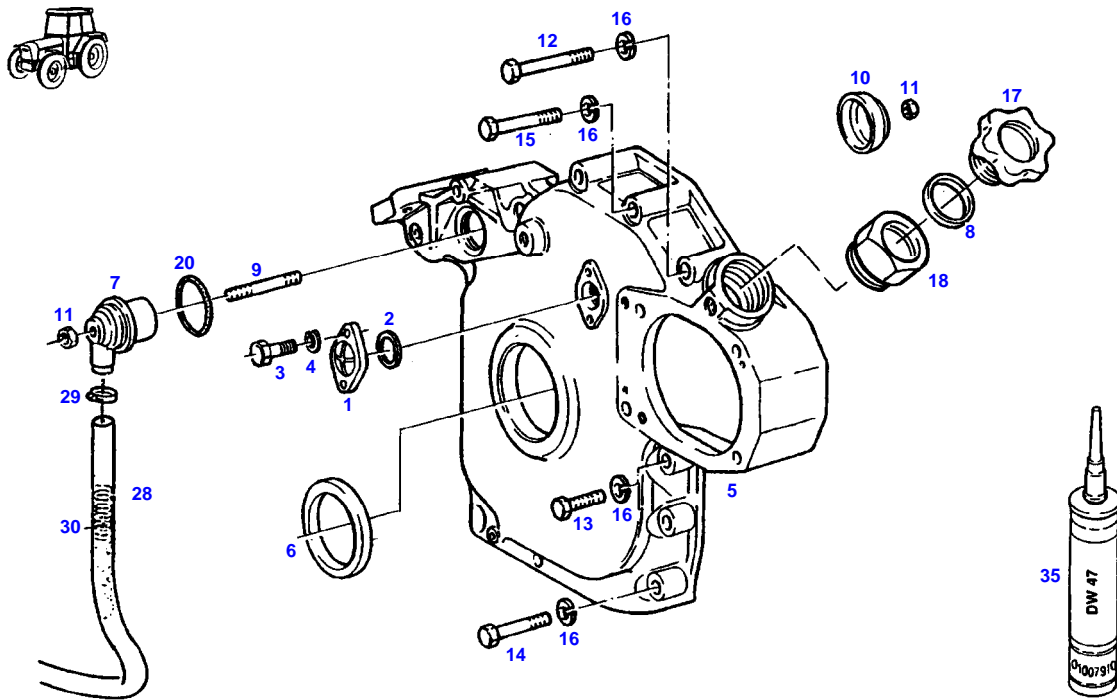

8328

Item	Part Number	Qty	Description Comments	Technical Specification
1	72343896	1	COVER	
2	72376544	1	O-RING	42,2X3-NBR 70 FWN56402
3	72315650	2	HEXAGONAL HEAD BOLT	DIN 933 M8 X 20-8.8A3L
4	72317121	2	SPRING WASHER	DIN 137 B8-MECH.VZK
5	72342971	1	CRANKCASE END COVER	
6	72332982	1	RADIAL SEALING RING	
7	72326907	1	HOUSING	
8	72376514	1	O-RING	32X4-NBR 70 FWN56402
9	72326906	1	THREADED PIN	
10	72326904	1	COVER PANEL	
11	72372804	2	NUT	DIN 934 M6-10
12	72315535	1	HEXAGONAL HEAD BOLT	DIN 931 M8X75 GWA-10.9
13	72315660	1	HEXAGONAL HEAD BOLT	DIN 933 M8X35-8.8A3L
14	72374372	7	HEXAGONAL HEAD BOLT	DIN 931 M8X45S-8.8
15	72315534	5	HEXAGONAL HEAD BOLT	DIN 931 M8 X 70-8.8
16	72315053	13	SPLIT WASHER	FWN 65208-8-A3L
17	72321607	1	PLUG	
18	72342977	1	EXTENSION TUBE	
20	72376538	1	O-RING	40X4
28	72436284	1	HOSE 1X 830MM CUT TO LENGTH	L=1120 FWN65912-19X3-PVC-W-G
29	72311166	1	HOSE CLIP	
30	72407980	1	COMPRESSION SPRING	
35	72311273	1	SEALING COMPOUND	TEROST-63S

FAVORIT 511 (511/00101-99999)
8329

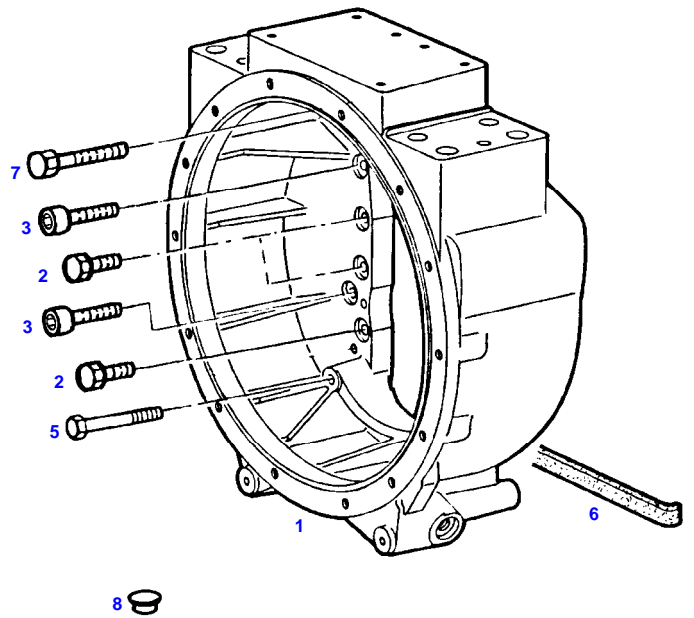
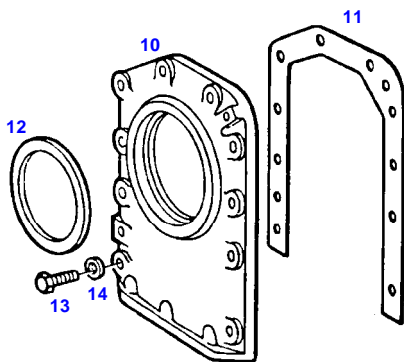

8329

Item	Part Number	Qty	Description Comments	Technical Specification
1	72407273	1	HOUSING	
2	72315686	10	HEXAGONAL HEAD BOLT	DIN 933-M10X35-12.9
3	72374073	4	SOCKET HEAD BOLT ALTERNATIVELY	DIN 912 M12X45-12.9
	72374469	4	HEXAGONAL HEAD BOLT ALTERNATIVELY	DIN 933-M12X45-12.9
5	72374189	2	HEXAGONAL HEAD BOLT	DIN 931 M10X85-12.9
6	72325584	1	RUBBER STRIP	
7	72374220	4	HEXAGONAL HEAD BOLT	DIN 931-M12X80-12.9
8	72314763	4	LOCKING PLUG F211	F211
	72375092	6	LOCKING PLUG F12	V14
	72375075	1	LOCKING PLUG F3	F3
	72314748	4	LOCKING PLUG F11	SW-F11
10	72330754	1	CRANKCASE END COVER ><12	
11	72330755	1	MOLDED SEAL	
12	72376834	1	SHAFT SEAL	110X130X14,5
13	72315652	10	HEXAGONAL HEAD BOLT	DIN 933 M8X25-8.8
14	72317121	10	SPRING WASHER	DIN 137 B8-MECH.VZK

FAVORIT 511 (511/00101-99999)
10873

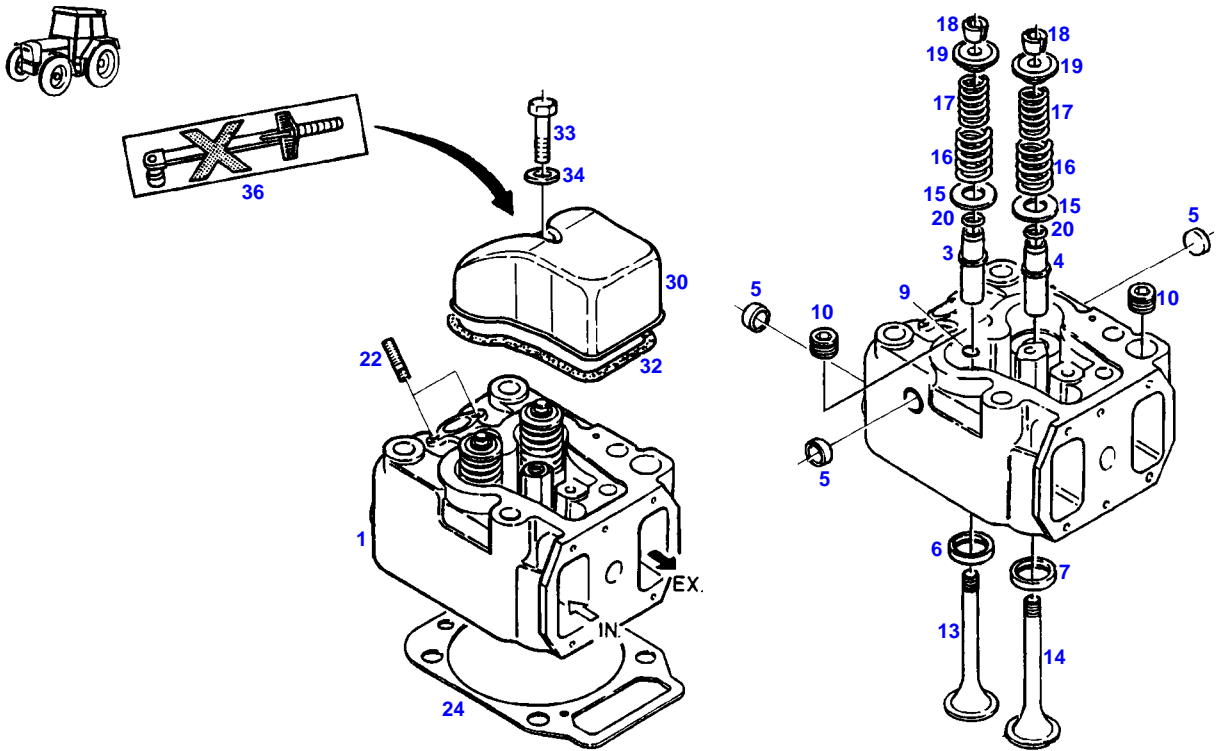

10873

CYLINDER HEAD

Item	Part Number	Qty	Description Comments	Technical Specification
1	72342949	6	CYLINDER HEAD ><3-20	
3	72343644	6	VALVE GUIDE INTAKE	
4	72343645	6	VALVE GUIDE OUTLET	
5	72311455	18	COVER	
6	72332986	6	VALVE SEAT RING INTAKE	
7	72343902	6	VALVE SEAT RING OUTLET	
9	72327100	12	LOCKWASHER	
10	72373948	12	PLUG SCREW	DIN 906 M22X1,5-ST
13	72332984	6	INLET VALVE CONE	
14	72332985	6	OUTLET VALVE CONE	
15	72340915	12	DISC	
16	72340913	12	VALVE SPRING	
17	72340914	12	VALVE SPRING	
18	72327092	24	TAPER PIECE HALF	
19	72327093	12	SPRING RETAINER	
20	72343647	12	SEAL	
22	72374627	12	STUD BOLT	DIN 939 M8X40-8.8
24	72343992	6	CYLINDER HEAD GASKET	
	72431774	1	REPAIR KIT	
30	72343906	6	CYLINDER HEAD COVER	
32	72343908	6	MOLDED SEAL	
33	72315659	6	HEXAGONAL HEAD BOLT	DIN 933 M8X35-8.8
34	72315087	6	SEALING WASHER	DIN 7603 A8X14-CU
36	72342973	6	LABEL	

FAVORIT 511 (511/00101-99999)
8796

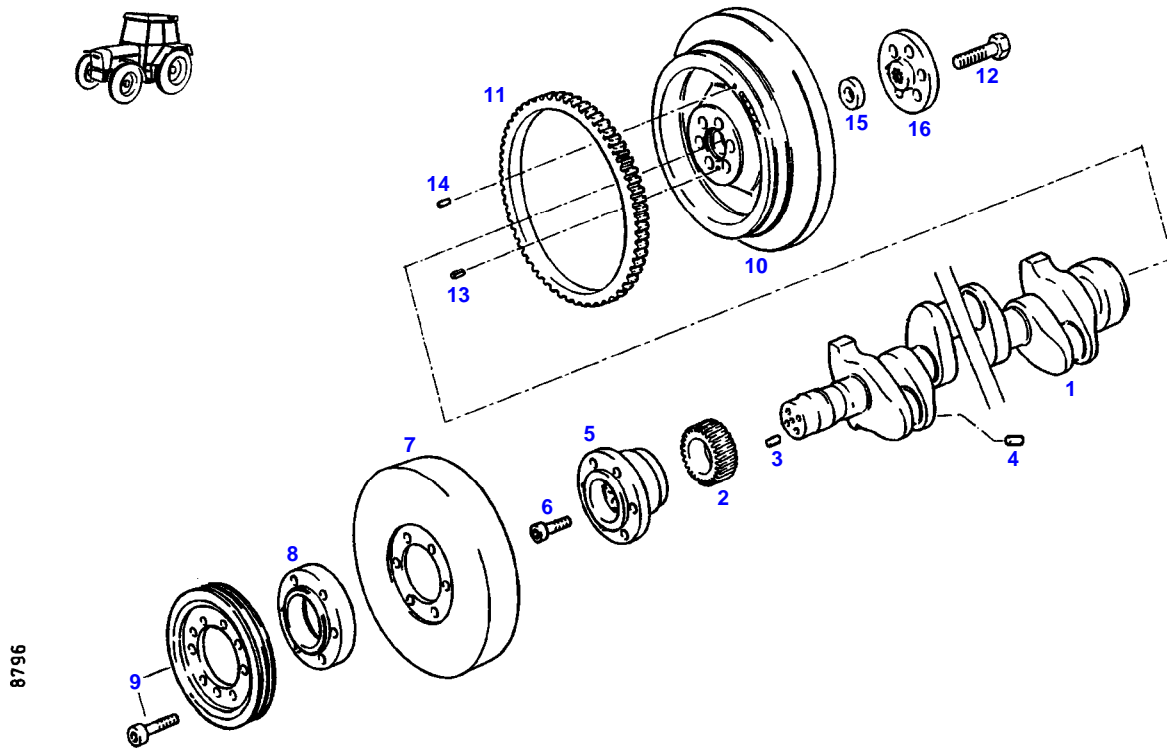

Item	Part Number	Qty	Description Comments	Technical Specification
1	72342979	1	CRANKSHAFT ><2-4	
2	72341105	1	SPUR GEAR	
3	72313801	1	TENSIONING PIN	ISO8752-4X14-A-ST
4	72337059	6	PLUG	
5	72332604	1	HUB	
6	72374113	4	SOCKET HEAD BOLT	DIN 912 M16X50-10.9
7	72344802	1	VIBRATION DAMPER	
8	72332603	1	INTERMEDIATE FLANGE	
9			SEE V-BELT	
10	72344803	1	FLYWHEEL ><11,14	
11	72330772	1	RING GEAR	
12	72315736	6	HEXAGONAL HEAD BOLT	DIN 933 M16X50 GWA-10.9
13	72375149	1	TENSIONING PIN	ISO8752-6X10-A-ST
14	72344730	1	PIN	
15	72341111	1	FLANGE BUSHING	
16	72410758	1	COUPLING FLANGE	

FAVORIT 511 (511/00101-99999)
3119

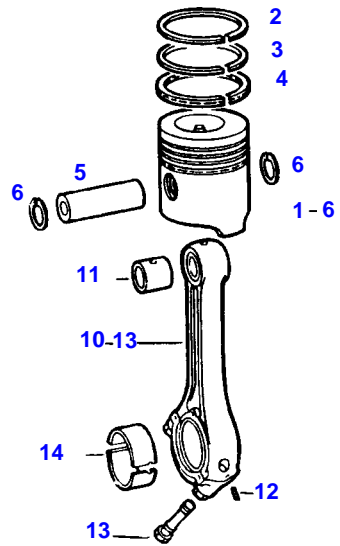

3119

Item	Part Number	Qty	Description Comments	Technical Specification
1	72333002	6	PISTON ><2-6	
2	72342952	6	PISTON RING KIT ><2-4	
3			NOT AVAILABLE IN SINGLE PARTS	
4			NOT AVAILABLE IN SINGLE PARTS	
5			NOT AVAILABLE IN SINGLE PARTS	
6	72332584	12	LOCKWASHER	
10	72343926	6	PISTON ROD ><11-13	
11	72341118	6	SMALL-END BUSH	
12	72313802	6	TENSIONING PIN	ISO8752-4X16-A-ST-ZNPHR10F-KOE
13	72327143	13	CONNECTING ROD BOLT	
14	72341119	6	CONNECTING ROD BEARING 63,00 MM	
	72341120	6	CONNECTING ROD BEARING 62,75 MM	
	72341121	6	CONNECTING ROD BEARING 62,50 MM	
	72341122	6	CONNECTING ROD BEARING 62,25 MM	
	72341123	6	CONNECTING ROD BEARING 62,00 MM	

FAVORIT 511 (511/00101-99999)
4689

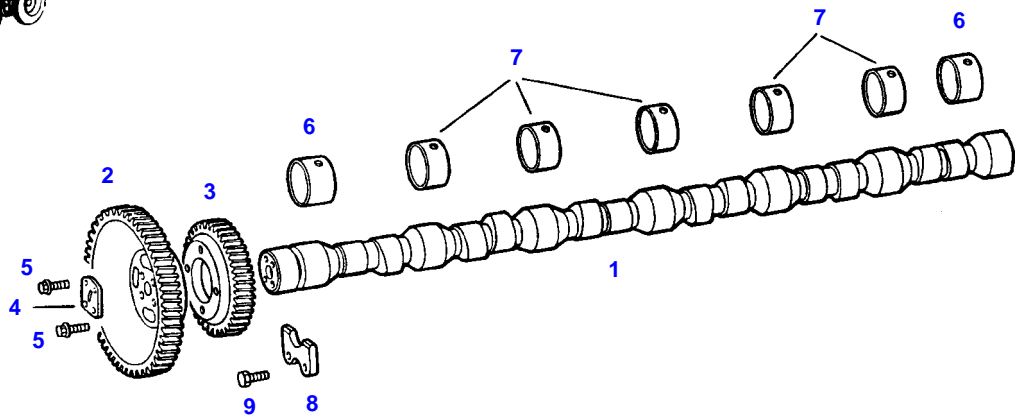

4689

Item	Part Number	Qty	Description Comments	Technical Specification
1	72333000	1	CAMSHAFT	
2	72343928	1	SPUR GEAR	
3	72343929	1	SPUR GEAR	
4	72331325	1	PROFILED FLANGE	
5	72375063	8	LOCK SCREW	FWN 64993 M8X22-12.9
6	72332989	2	BUSH REPAIR STEP	
7	72332990	5	BUSH REPAIR STEP	
8	72343930	1	SEGMENT	
9	72375061	2	LOCK SCREW	W151.12 M8X16-90

FAVORIT 511 (511/00101-99999)
3121

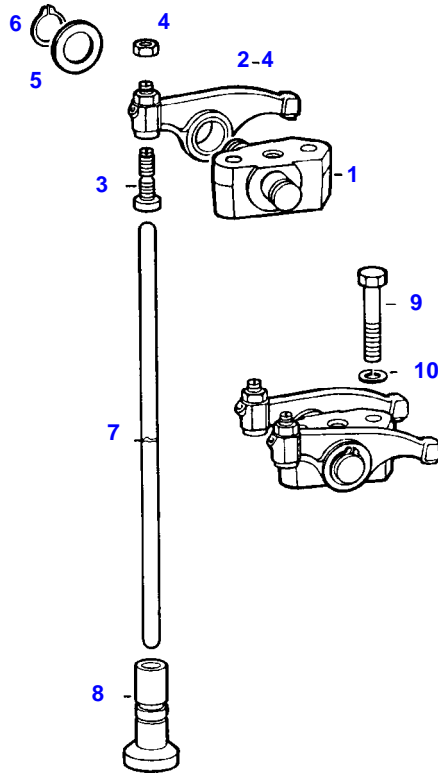

3121

Item	Part Number	Qty	Description Comments	Technical Specification
1	72343933	6	ROCKER ARM SUPPORT	
2	72343934	12	ROCKER ARM ><3+4	
3	72343935	12	ADJUSTING SCREW	
4	72343936	12	NUT	
5	72321237	24	DISC	
6	72375559	12	LOCK WASHER	DIN 471-16X1
7	72330785	12	BUMPER	
8	72343937	12	MUSHROOM TAPPET	
	72423816	12	MUSHROOM TAPPET OVERSIZE 19,5 MM	
9	72315691	12	HEXAGONAL HEAD BOLT	DIN 933 M10X40-8.8A3L
10	72315054	12	SPLIT WASHER	FWN 65208-10-A3L

FAVORIT 511 (511/00101-99999)
9452

9452

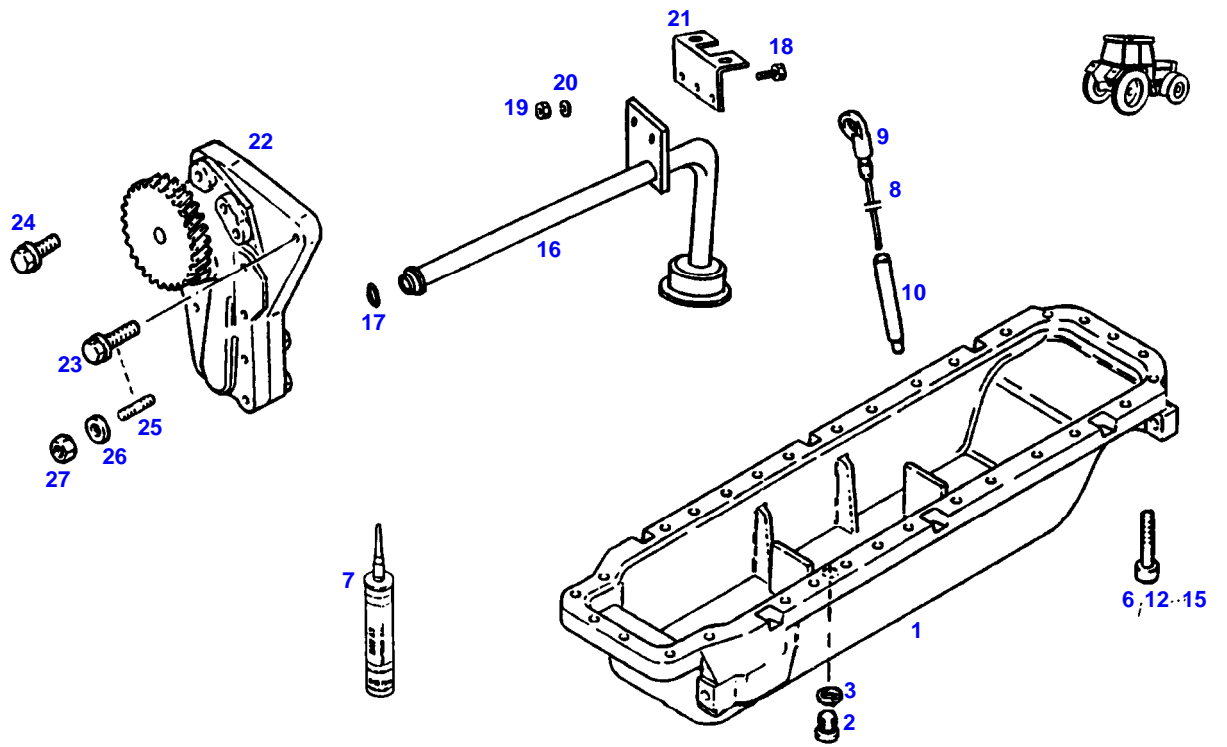

Item	Part Number	Qty	Description Comments	Technical Specification
1	72344731	1	OIL PAN ><2,3	
2	72373963	1	HEX CAP SCREW	DIN 908-G1/2A-ST
3	72332580	1	SEALING WASHER	
6	72374041	3	SOCKET HEAD BOLT	DIN 912-M8X170-10.9
7	72311273	1	SEALING COMPOUND	TEROST-63S
8	72344732	1	DIPSTICK	
9	72376384	1	O-RING	7,3X2,4
10	72329118	1	PIPE	
11	72374024	7	SOCKET HEAD BOLT	DIN 912-M8X45-10.9
12	72315484	18	SOCKET HEAD BOLT	DIN 912 M8X65-10.9A3L
13	72374032	2	SOCKET HEAD BOLT	DIN 912 M8X100-10.9
14	72374038	3	SOCKET HEAD BOLT	DIN 912 M8X140-10.9
15	72374073	4	SOCKET HEAD BOLT	DIN 912 M12X45-12.9
16	72340916	1	LUBE OIL LINE	
17	72376491	1	O-RING 25X4	25X4-FPM 70 FWN56402
	72376462	1	O-RING 20X4	20X4-FPM 70 FWN56402
18	72315642	2	HEXAGONAL HEAD BOLT	DIN 933 M8 X 16-8.8A3L
19	72313268	2	NUT	DIN 934 M8-8A3L
20	72315053	2	SPLIT WASHER	FWN 65208-8-A3L
21	72330779	1	GUSSET PLATE	
22	72332187	1	OIL GEAR PUMP	
23	72375067	1	LOCK SCREW	FWN 64993 M8X35-90
24	72375063	1	LOCK SCREW	FWN 64993 M8X22-12.9
25	72374623	1	STUD BOLT	DIN 939-M8X25-8.8
26	72340920	1	DISC	
27	72340921	1	MIDGRIP NUT	

FAVORIT 511 (511/00101-99999)
7705

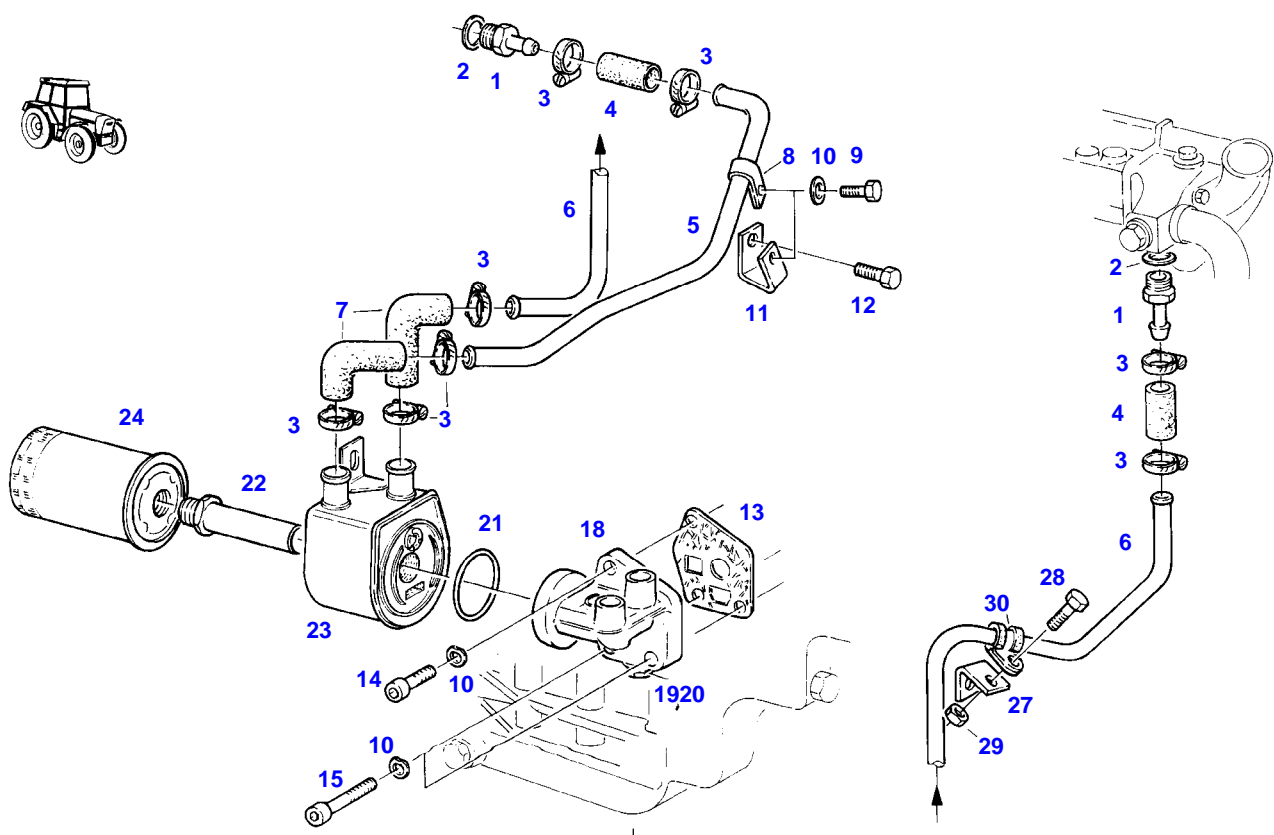

7705

Item	Part Number	Qty	Description Comments	Technical Specification
			<-- 511/0101 --> 511/0300 <-- 511/1001 --> 511/3000	
1	72396595	2	HOSE BARB	
2	72315101	2	SEALING WASHER	DIN 7603 A22X27-CU
3	72311167	8	HOSE CLIP	
4	72396335	2	HOSE PIECE	
5	72397336	1	COOLANT LINE	
6	72397337	1	COOLANT LINE	
7	72435869	2	RUBBER ARCH	
8	72386726	1	PIPE CLAMP	
9	72315675	1	HEXAGONAL HEAD BOLT	DIN 933 M10X16-8.8A3L
10	72317122	4	SPRING WASHER	DIN 137 B10-MECH.VZK
11	72397289	1	RETAINER	
12	72315704	1	HEXAGONAL HEAD BOLT	DIN 933 M12X16-8.8A3L
13	72327148	1	MOLDED SEAL	
14	72315494	1	SOCKET HEAD BOLT	DIN 912 M10X30-8.8
15	72315498	2	SOCKET HEAD BOLT	DIN 912 M10X40-8.8 OB1-SW
18	72325601	1	FILTER HEAD ><19+20 <-- G510.201.900.100	
19	72325606	1	VALVE	
20	72376031	1	SEALING WASHER	DIN 7603 A20X24-CU
21	72396334	1	O-RING	
22	72395901	1	SCREW PIECE	
23	72348781	1	OIL COOLER <>	
	72327148	1	MOLDED SEAL	
	72315797	1	PLUG SCREW	DIN 7604 AM10X1-ST A3L
	72315088	1	SEALING WASHER	DIN 7603 A10X13,5-CU
24	72334900	1	OIL FILTER	
27	72397338	1	ANGLE	
28	72315626	1	HEXAGONAL HEAD BOLT	DIN 933-M6 X 16-8.8-A3L
29	72313266	1	NUT	DIN 934 M6-8A3L
30	72311247	1	PIPE CLAMP	

FAVORIT 511 (511/00101-99999)
10429

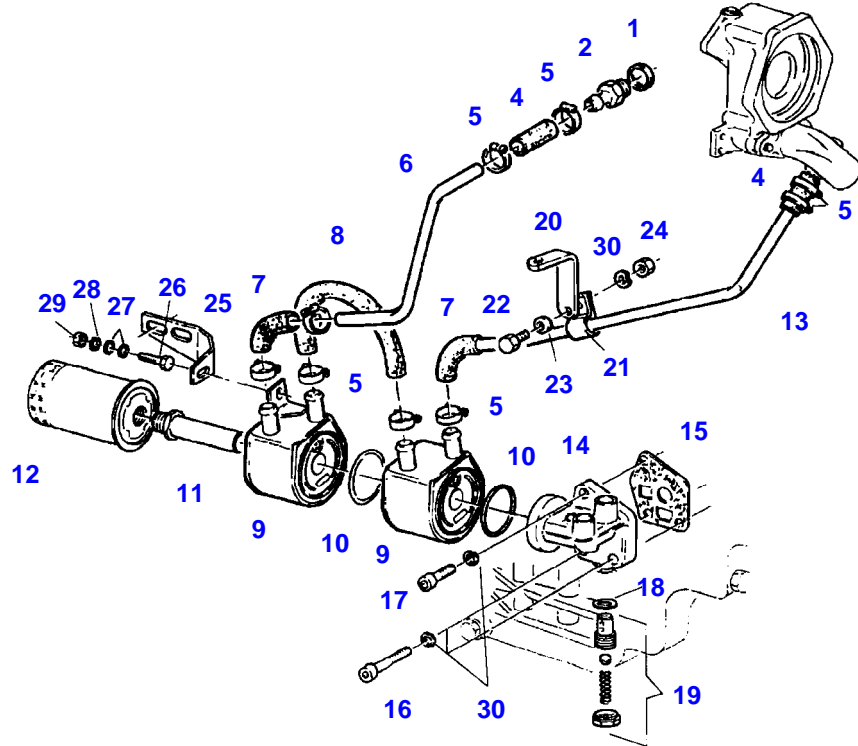

010429

Item	Part Number	Qty	Description Comments	Technical Specification
			<-- 511/0301 --> 511/0400 <-- 511/3001 --> 511/3131	
1	72315101	1	SEALING WASHER	DIN 7603 A22X27-CU
2	72396595	1	HOSE BARB	
4	72396335	2	HOSE PIECE	
5	72311167	10	HOSE CLIP	
6	72410910	1	COOLANT LINE	
7	72435869	2	RUBBER ARCH	
8	72395937	1	HOSE ARCH	
9	72350047	1	OIL COOLER SUPERSESION CONTENTS 2 PCE.	
	72315797	1	PLUG SCREW	DIN 7604 AM10X1-ST A3L
	72315088	1	SEALING WASHER	DIN 7603 A10X13,5-CU
10	72396334	2	O-RING	
11	72409108	1	SCREW PIECE	
12	72311026	1	OIL FILTER	
13	72407560	1	COOLANT LINE	
14	72350653	1	FILTER HEAD ><18,19	
15	72327148	1	MOLDED SEAL	
16	72374992	2	SOCKET HEAD BOLT	DIN 7984 M10X40-8.8
17	72374991	1	SOCKET HEAD BOLT	DIN 7984 M10X30-8.8
18	72376031	1	SEALING WASHER	DIN 7603 A20X24-CU
19	72341135	1	VALVE	
20	72407558	1	ANGLE	
21	72386726	1	PIPE CLAMP	
22	72315679	1	HEXAGONAL HEAD BOLT	DIN 933 M10X20-8.8A3L
23	72311789	1	DISC	DIN 125-10,5-ST.A3L
24	72313272	1	NUT	DIN 934 M10-8A3L
25	72395940	1	RETAINER	
26	72315642	1	HEXAGONAL HEAD BOLT	DIN 933 M8 X 16-8.8A3L
27	72311788	2	DISC	DIN 125-8,4-ST.A3L
28	72317121	1	SPRING WASHER	DIN 137 B8-MECH.VZK
29	72313268	1	NUT	DIN 934 M8-8A3L
30	72317122	4	SPRING WASHER	DIN 137 B10-MECH.VZK

FAVORIT 511 (511/00101-99999)
31795

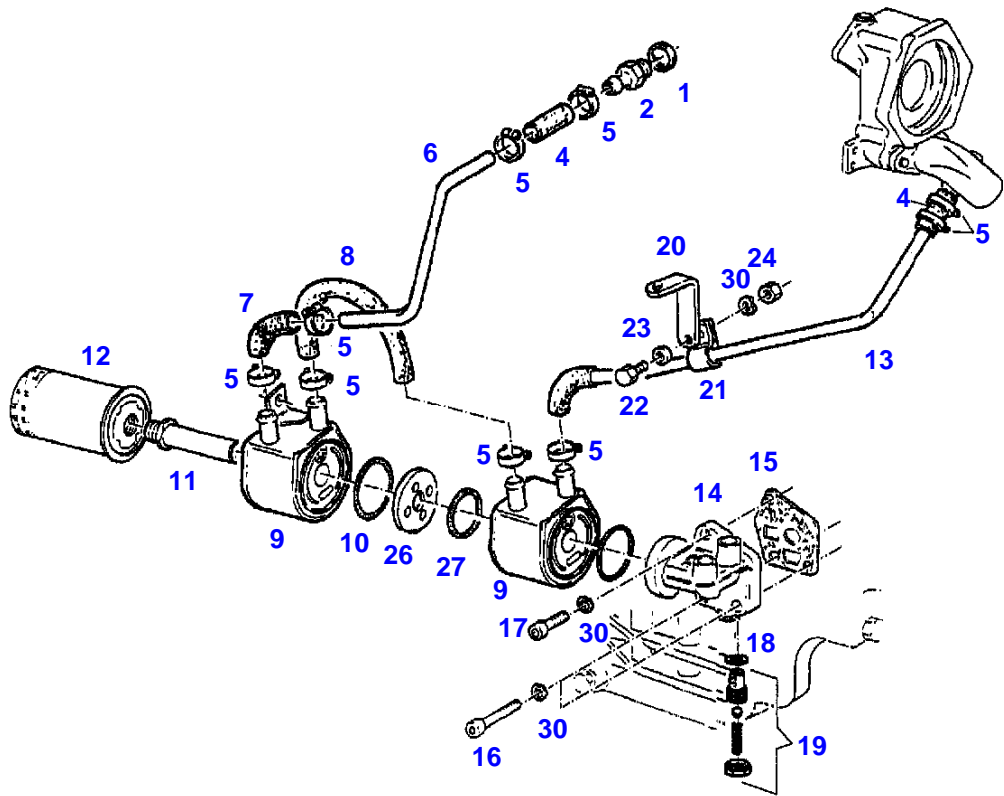

031795

Item	Part Number	Qty	Description Comments	Technical Specification
			<-- 511/3132	
1	72315101	1	SEALING WASHER	DIN 7603 A22X27-CU
2	72396595	1	HOSE BARB	
4	72396335	2	HOSE PIECE	
5	72311167	10	HOSE CLIP	
6	72410910	1	COOLANT LINE	
7	72435869	2	RUBBER ARCH	
8	72395937	1	HOSE ARCH	
9	72350652	2	OIL COOLER	
	72315797	2	PLUG SCREW	DIN 7604 AM10X1-ST A3L
	72315088	2	SEALING WASHER	DIN 7603 A10X13,5-CU
10	72410911	2	SEALING RING	
11	72410909	1	SCREW PIECE	
12	72311026	1	OIL FILTER	
13	72407560	1	COOLANT LINE	
14	72350565	1	FILTER HEAD	
			><18,19	
15	72327148	1	MOLDED SEAL	
16	72374992	2	SOCKET HEAD BOLT	DIN 7984 M10X40-8.8
17	72374991	1	SOCKET HEAD BOLT	DIN 7984 M10X30-8.8
18	72376031	1	SEALING WASHER	DIN 7603 A20X24-CU
19	72325606	1	VALVE	
20	72407558	1	ANGLE	
21	72386726	1	PIPE CLAMP	
22	72315679	1	HEXAGONAL HEAD BOLT	DIN 933 M10X20-8.8A3L
23	72311789	1	DISC	DIN 125-10,5-ST.A3L
24	72313272	1	NUT	DIN 934 M10-8A3L
26	72410908	1	INTERMEDIATE PLATE	
27	72410912	1	SEAL	
30	72317122	4	SPRING WASHER	DIN 137 B10-MECH.VZK



Suggest:

For more complete manuals. Please go to the home page.

<https://www.ebooklibonline.com>

If the above button click is invalid. Please download this document first, and then click the above link to download the complete manual.

Thank you so much for reading

FAVORIT 511 (511/00101-99999)
11782

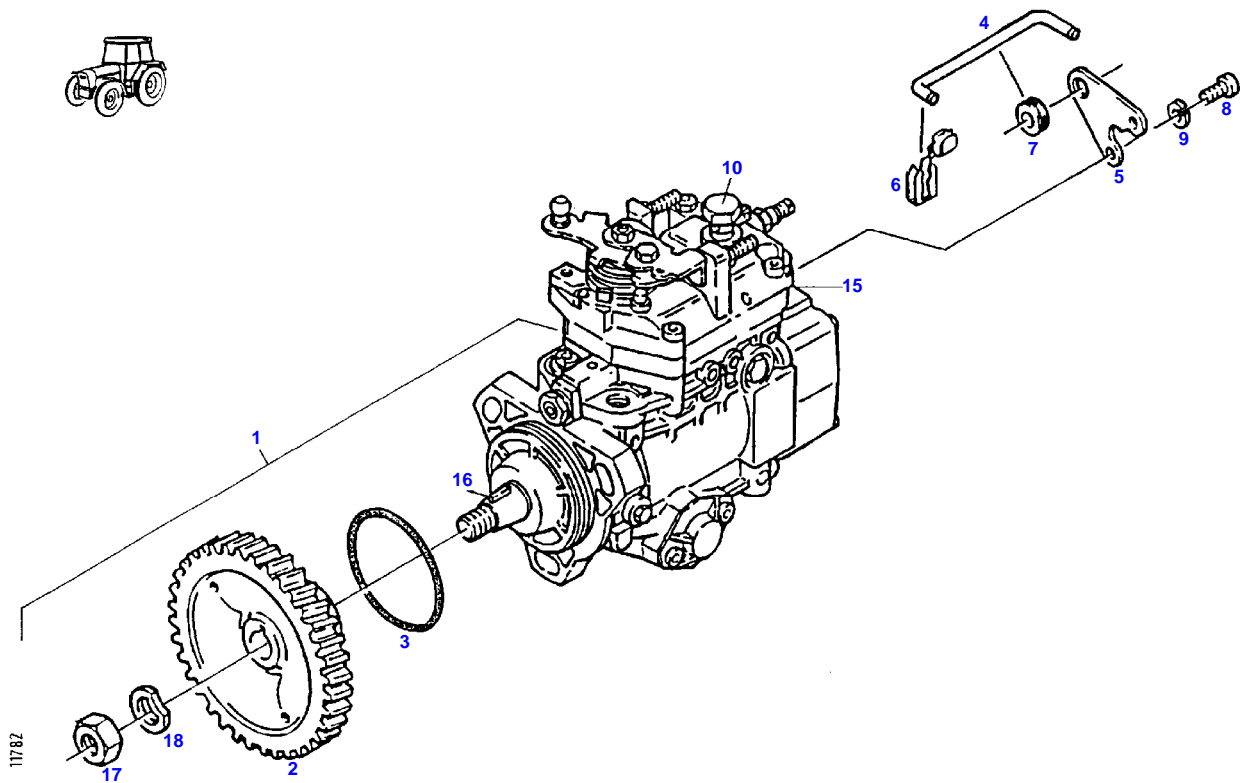

Item	Part Number	Qty	Description Comments	Technical Specification
			<-- 511/0101 --> 511/0400 <-- 511/1001 --> 511/3176	
1	72342990	1	INJECTION PUMP >>10,15-18	
2	72342991	1	SPUR GEAR	
3	72342992	1	O-RING	
4	72410862	1	ROD <>	
	72310445	1	BOLT	FWN 64072 6X12 A3L
	72410863	1	RETAINING SHEET METAL	
	72311306	1	CLEVIS	DIN 71752 G6X12-A3L
	72313266	1	NUT	DIN 934 M6-8A3L
5	72410863	1	RETAINING SHEET METAL <>	
	72311306	1	CLEVIS	DIN 71752 G6X12-A3L
	72310445	1	BOLT	FWN 64072 6X12 A3L
	72410862	1	ROD	
	72313266	1	NUT	DIN 934 M6-8A3L
6	72342995	1	LOCK SPRING	
7	72316354	1	CABLE BUSHING	9X12X16
8	72374005	1	SOCKET HEAD BOLT	DIN 912 M6X16-10.9
9	72315052	1	SPLIT WASHER	FWN 65208-6-A3L
10	72315350	1	BANJO BOLT	
15	72316840	1	SOLENOID SWITCH	
16	72416161	1	FITTING KEY	
17	72313281	1	NUT	DIN 934 M14X1,5-8A3L
18	72315056	1	SPLIT WASHER	FWN 65208-14-A3L

<https://www.ebooklibonline.com>

Hello dear friend!

Thank you very much for reading.

Enter the link into your browser.

The full manual is available for immediate download.

<https://www.ebooklibonline.com>