

Page Number	Page Title	Page Reference
01-000-TOC	ENGINE, FUEL AND EXHAUST SYSTEM	01-000-TOC
02-000-TOC	AXLES	02-000-TOC
03-000-TOC	STEERING SYSTEM	03-000-TOC
04-000-TOC	DRIVE TRAIN SYSTEM	04-000-TOC
05-000-TOC	COMPRESSED AIR SYSTEM	05-000-TOC
06-000-TOC	HYDRAULIC SYSTEM	06-000-TOC
07-000-TOC	ELECTRICAL SYSTEM	07-000-TOC
08-000-TOC	CAB	08-000-TOC
09-000-TOC	AIR CONDITIONING AND HEATING SYSTEM	09-000-TOC
10-000-TOC	CHASSIS	10-000-TOC
11-000-TOC	WHEELS	11-000-TOC
12-000-TOC	IMPLEMENT LIFT SYSTEM FRONT	12-000-TOC
13-000-TOC	IMPLEMENT LIFT SYSTEM REAR	13-000-TOC
14-000-TOC	FRONT/REAR LOADERS	14-000-TOC
15-000-TOC	ACCESSORIES	15-000-TOC

FARMER 409 (409/00101-99999)
33869

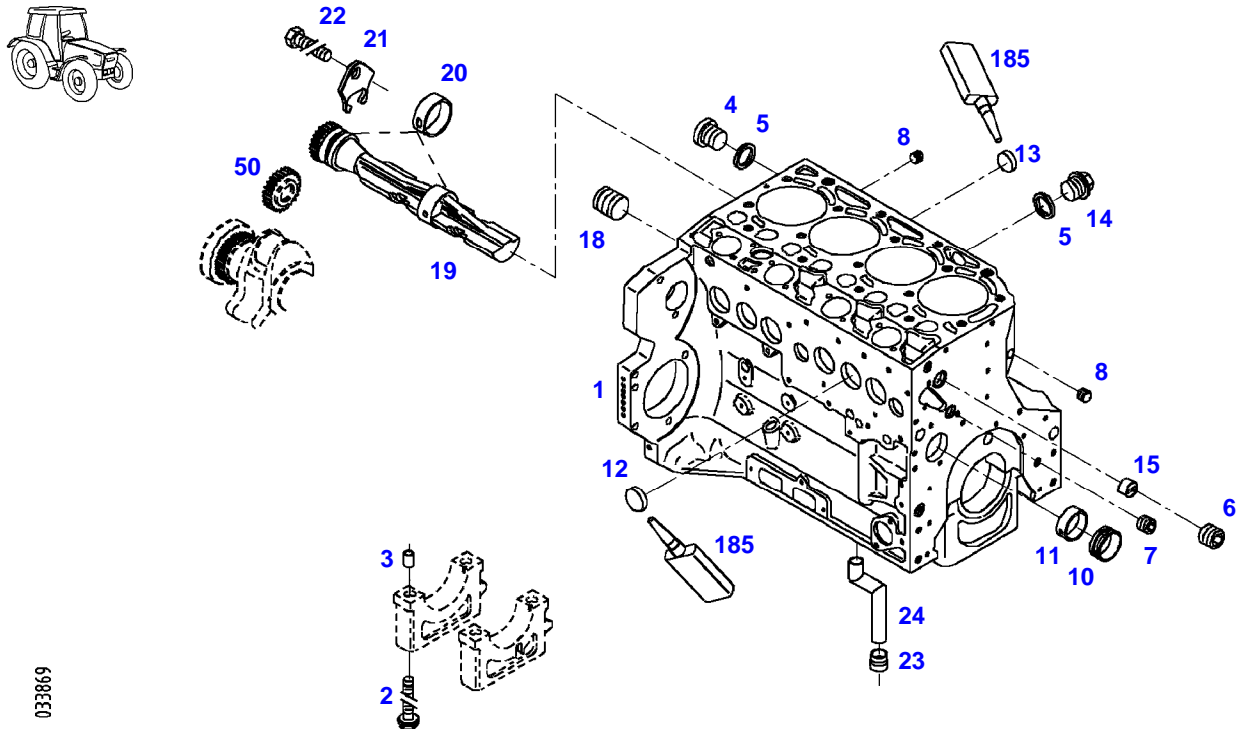

033869

Item	Part Number	Qty	Description Comments	Technical Specification
			ENGINE NUMBER <-- 1065824	
	72426998	1	ENGINE ENGINE NEW FLYWHEEL MUST BE CHANGED IF A NEW ENGINE IS SUPPLIED --> 409/4895 <-- Z409.202.010.010 ENGINE EXCHANGE WHEN ORDERING ALWAYS INDICATE ENGINE NO. AND KILOWATT RATING	BF04M2013C
	72604526	1	REMANUFACTURED SHORT BLOCK ENGINE --> 409/4895	
	72451247	1	ENGINE ENGINE NEW <-- 409/4896 <-- Z409.202.010.011 ENGINE EXCHANGE	BF04M2013C
	72604526	1	REMANUFACTURED SHORT BLOCK ENGINE <-- 409/4896	
1	72609289	1	CRANKCASE ><2-15,18-24	
2	72416467	10	HEXAGONAL HEAD BOLT	
3	72344342	10	ADAPTER BUSH	
4	72315438	1	PLUG SCREW	DIN 908 M14X1,5-ST
5	72315095	3	SEALING WASHER	DIN 7603 A14X20-CU
6	72325319	1	PLUG 30X1,5	
7	72325321	1	PLUG 22X1,5	
8	72429347	2	SCREW 14X1,5	M14X1,5
10	72416469	4	BEARING BUSHING	
11	72416470	1	BEARING BUSHING	
12	72325325	6	CORE HOLE PLUG	
13	72325326	4	CORE HOLE PLUG	
14	72315799	2	PLUG	DIN 7604 AM14X1,5-A3L
15	72325327	1	GUIDE SLEEVE	
18	72431135	1	LOCKING PLUG	
19	72429813	2	GANG SHAFT	
20	72325339	4	BUSH	
21	72415943	2	THRUST WASHER	
22	72423137	2	HEXAGONAL HEAD BOLT M8X16	
23	72420773	1	LOCKING PART	
24	72420774	1	LINE	
50				
185	72325403	1	SEE BALANCER GEARS SAFE.LOCK AGENT	

<https://www.ebooklibonline.com>

Hello dear friend!

Thank you very much for reading.

Enter the link into your browser.

The full manual is available for immediate download.

<https://www.ebooklibonline.com>



Fendt

FARMER 409 (409/00101-99999)

F409000

CRANKCASE

Page01-0006

Item	Part Number	Qty	Description Comments	Technical Specification
BLANKING PARTS				
1	72627515	1	CORE HOLE PLUG	
2	72315088	2	SEALING WASHER	DIN 7603 A10X13,5-CU
3	72323677	2	PLUG	
4	72631860	2	SLUG	
185	72325403	1	SAFE.LOCK AGENT	

FARMER 409 (409/00101-99999)
30094

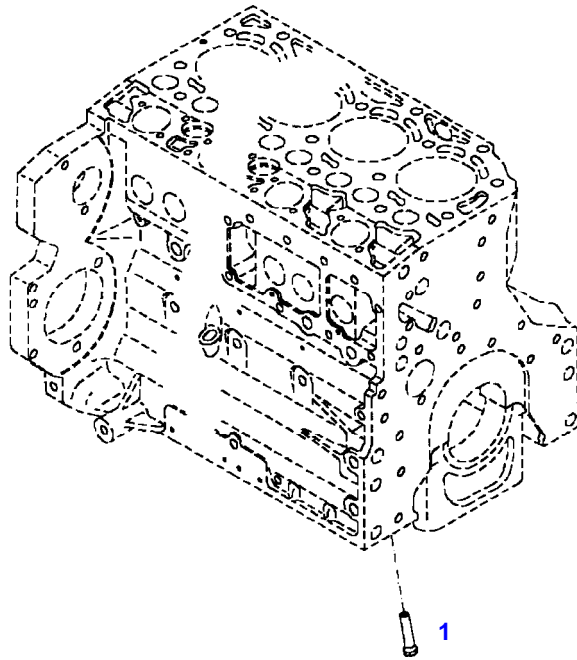

030004

Fendt

FARMER 409 (409/00101-99999)

F409000

CRANKCASE

Page01-0007

Item	Part Number	Qty	Description Comments
			PISTON COOL.NOZZLE
1	72415140	4	PISTON COOLING JET

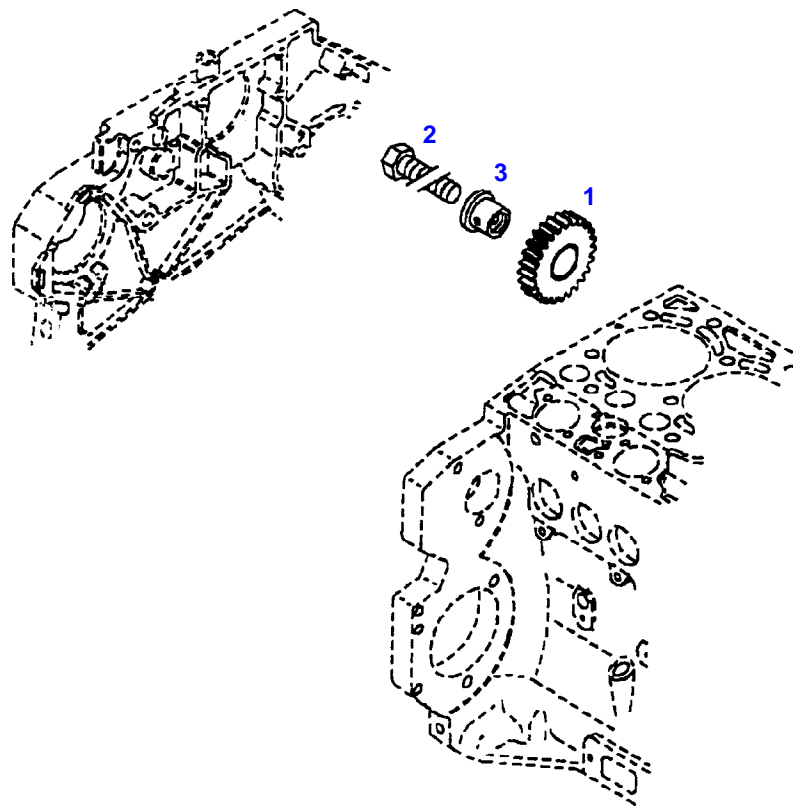

12057

Fendt

FARMER 409 (409/00101-99999)

F409000

CRANKCASE

Page01-0008

Item	Part Number	Qty	Description Comments	Technical Specification
			INTERM. GEAR WHEEL	
1	72325335	1	GEAR WHEEL	
2	72315658	1	HEXAGONAL HEAD BOLT	DIN 933 M8X35-10.9
3	72325336	1	PIVOT	

FARMER 409 (409/00101-99999)
40194

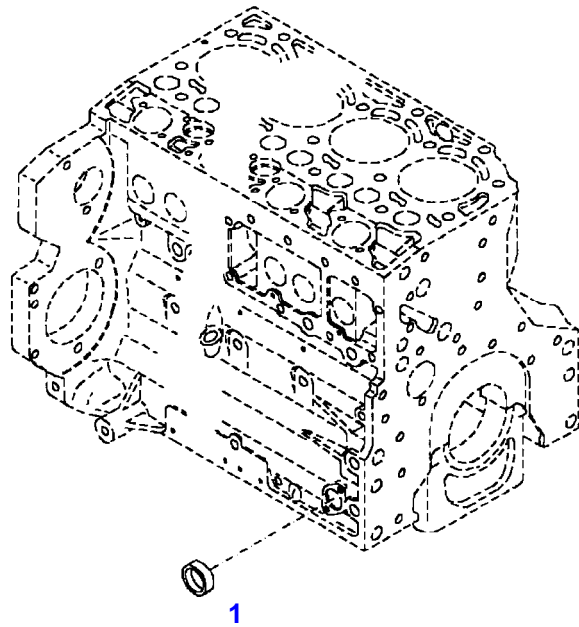

040194

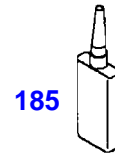

Fendt

FARMER 409 (409/00101-99999)

F409000

CRANKCASE

Page01-0009

Item	Part Number	Qty	Description Comments
			LOCKING PLUG
1	72325326	1	CORE HOLE PLUG
185	72325403	1	SAFE.LOCK AGENT

FARMER 409 (409/00101-99999)
F51551

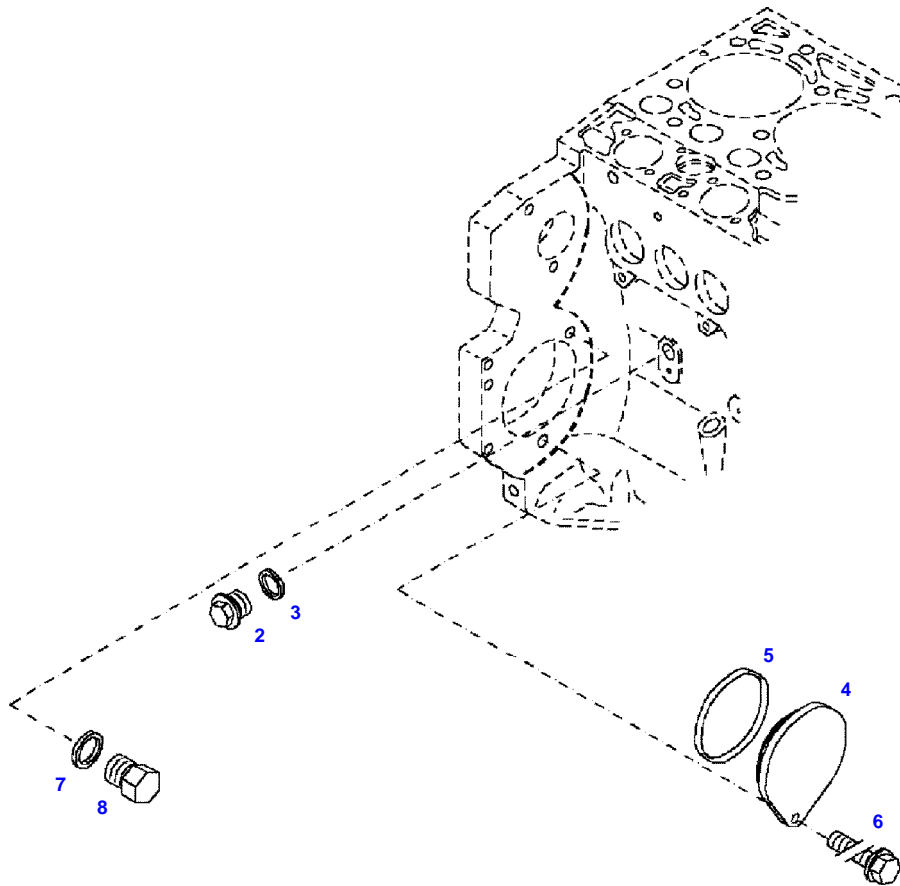

051551



Item	Part Number	Qty	Description Comments	Technical Specification
			BLANKING PARTS ENGINE NUMBER --> 825775	
2	72315799	1	PLUG NOT NEEDED WITH AIR BRAKE	DIN 7604 AM14X1,5-A3L
3	72315094	1	SEALING WASHER NOT NEEDED WITH AIR BRAKE	DIN 7603 A14X18-CU
4	72431648	1	COVER NOT NEEDED WITH AIR BRAKE	
5	72416472	1	SEAL 96X4MM NOT NEEDED WITH AIR BRAKE	
6	72621034	1	HEXAGONAL HEAD BOLT NOT NEEDED WITH AIR BRAKE	M10X20
7	72315088	1	SEALING WASHER	DIN 7603 A10X13,5-CU
8	72323677	1	PLUG	

FARMER 409 (409/00101-99999)
F51552

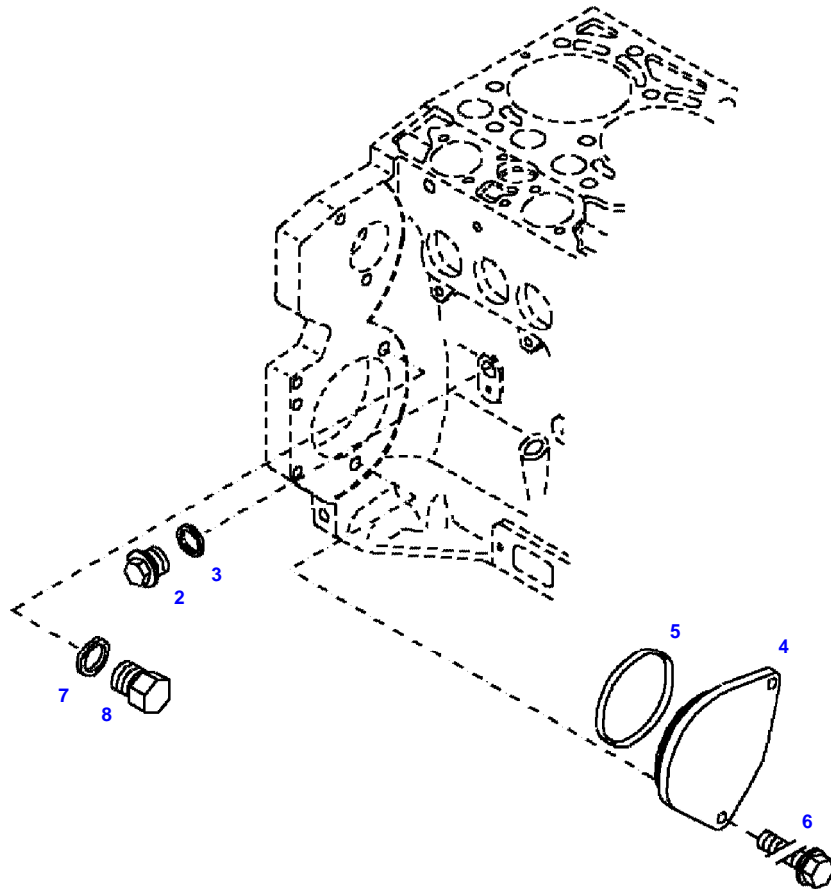

051552



Item	Part Number	Qty	Description Comments	Technical Specification
			BLANKING PARTS ENGINE NUMBER <-- 825776	
2	72315799	1	PLUG NOT NEEDED WITH AIR BRAKE	DIN 7604 AM14X1,5-A3L
3	72315094	1	SEALING WASHER NOT NEEDED WITH AIR BRAKE	DIN 7603 A14X18-CU
4	72431648	1	COVER NOT NEEDED WITH AIR BRAKE	
5	72416472	1	SEAL 96X4MM NOT NEEDED WITH AIR BRAKE	
6	72621034	2	HEXAGONAL HEAD BOLT NOT NEEDED WITH AIR BRAKE	M10X20
7	72315088	1	SEALING WASHER	DIN 7603 A10X13,5-CU
8	72323677	1	PLUG	

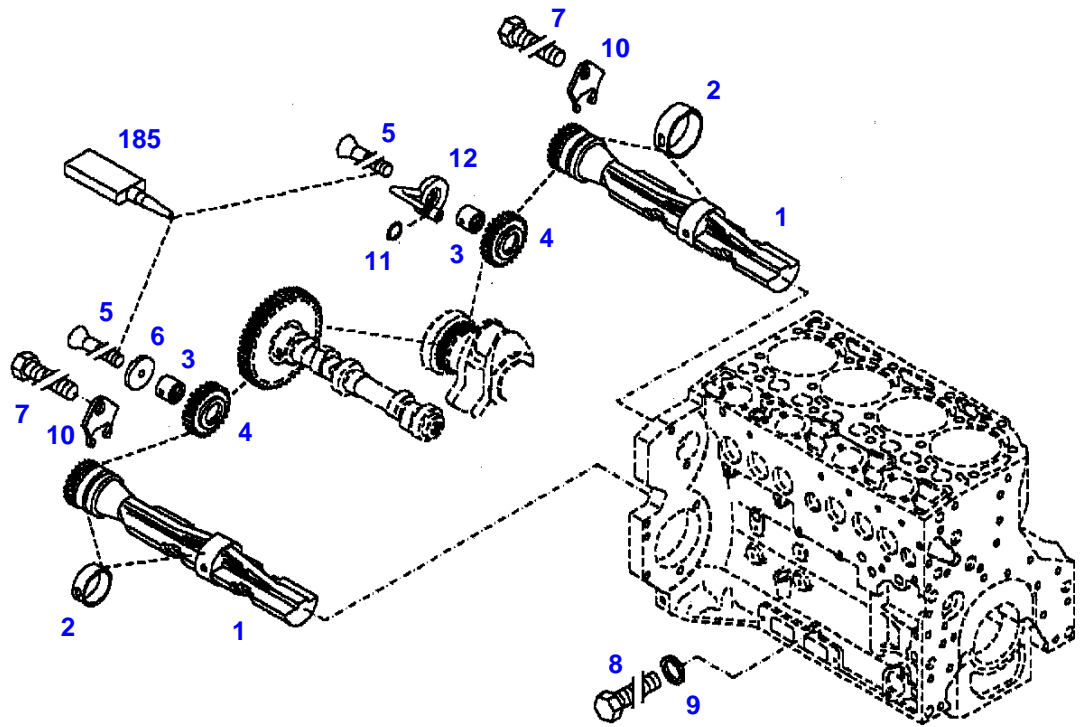

031426

Item	Part Number	Qty	Description Comments	Technical Specification
			ENGINE NUMBER --> 860751	
1	72429813	1	GANG SHAFT	
2	72325339	4	BUSH	
3	72415940	2	PIVOT	
4	72415941	2	GEAR WHEEL	
5	72423136	2	COUNTERSUNK CAPSCREW M8X45	
6	72415942	1	FIXING SHIM	
7	72423137	2	HEXAGONAL HEAD BOLT M8X16	
8	72315644	2	HEXAGONAL HEAD BOLT	DIN 933 M8X10-8.8A3L
9	72315086	2	SEALING WASHER	DIN 7603 A8X11,5-CU
10	72415943	2	THRUST WASHER	
11	72423138	1	SEAL 7X1,5MM	
12	72415945	1	PIVOT	
185	72381391	1	THREADLOCKER	LOCTITE 243 10ML

FARMER 409 (409/00101-99999)
33867

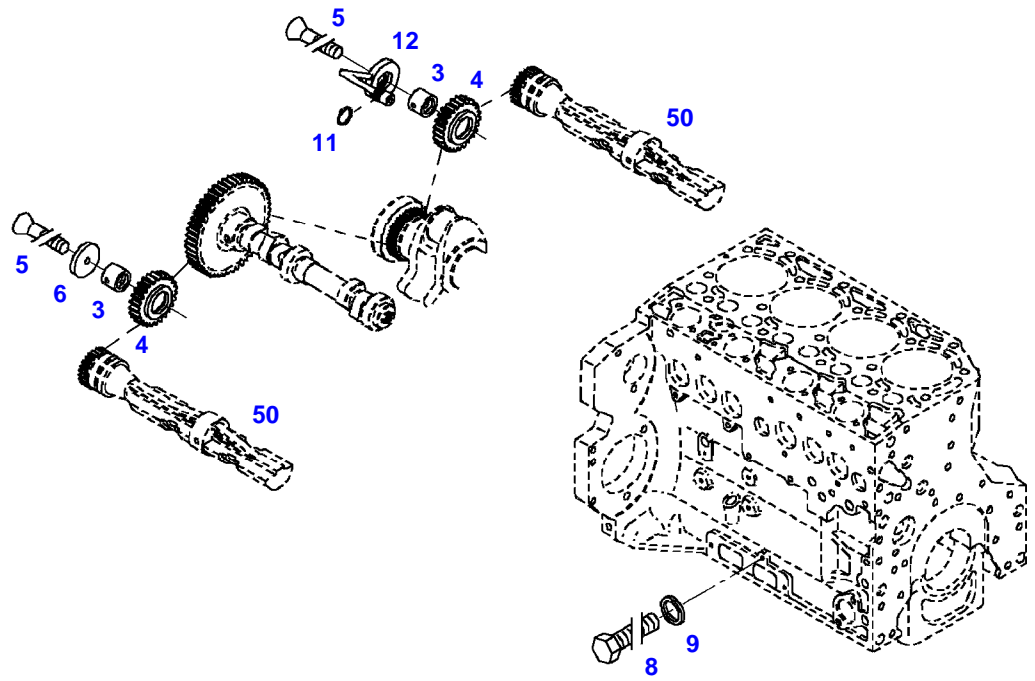

033867

Item	Part Number	Qty	Description Comments	Technical Specification
			ENGINE NUMBER <-- 860752	
3	72415940	2	PIVOT	
4	72415941	2	GEAR WHEEL	
5	72423136	2	COUNTERSUNK CAPSCREW M8X45	
6	72415942	1	FIXING SHIM	
8	72315644	2	HEXAGONAL HEAD BOLT	DIN 933 M8X10-8.8A3L
9	72315087	2	SEALING WASHER	DIN 7603 A8X14-CU
11	72423138	1	SEAL 7X1,5MM	
12	72415945	1	PIVOT	
50			SEE CRANKCASE	

FARMER 409 (409/00101-99999)
40029

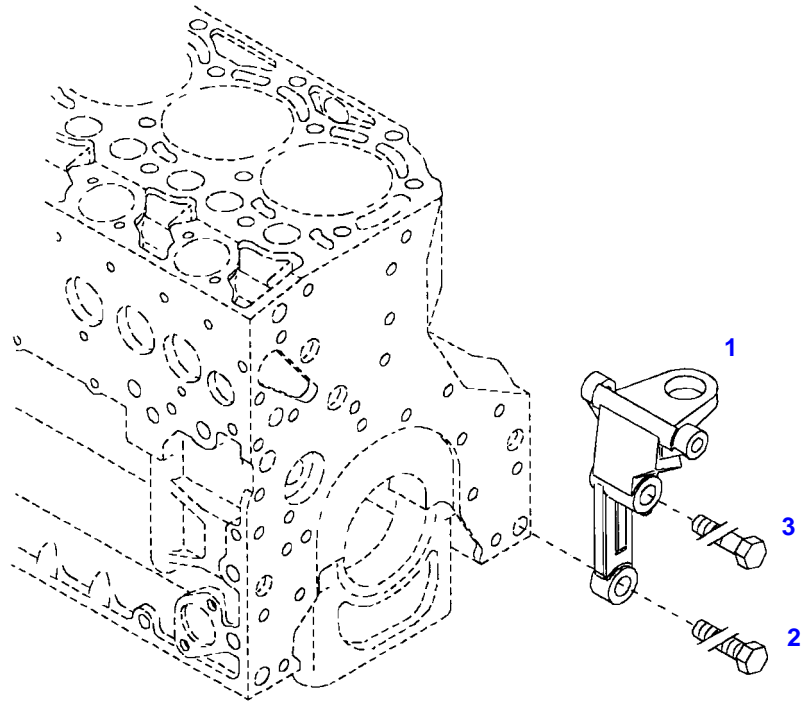

040029

Fendt

FARMER 409 (409/00101-99999)

F409000

ENGINE MOUNTINGS

Page01-0014

Item	Part Number	Qty	Description Comments	Technical Specification
			LEFT	
1	72428791	1	ENGINE SUSPENSION	
2	72418408	1	HEXAGONAL HEAD BOLT	DIN 933 M16X40 GWA-10.9
3	72374294	1	HEXAGONAL HEAD BOLT	DIN 931-M16X85 GWA-10.9

FARMER 409 (409/00101-99999)
40030

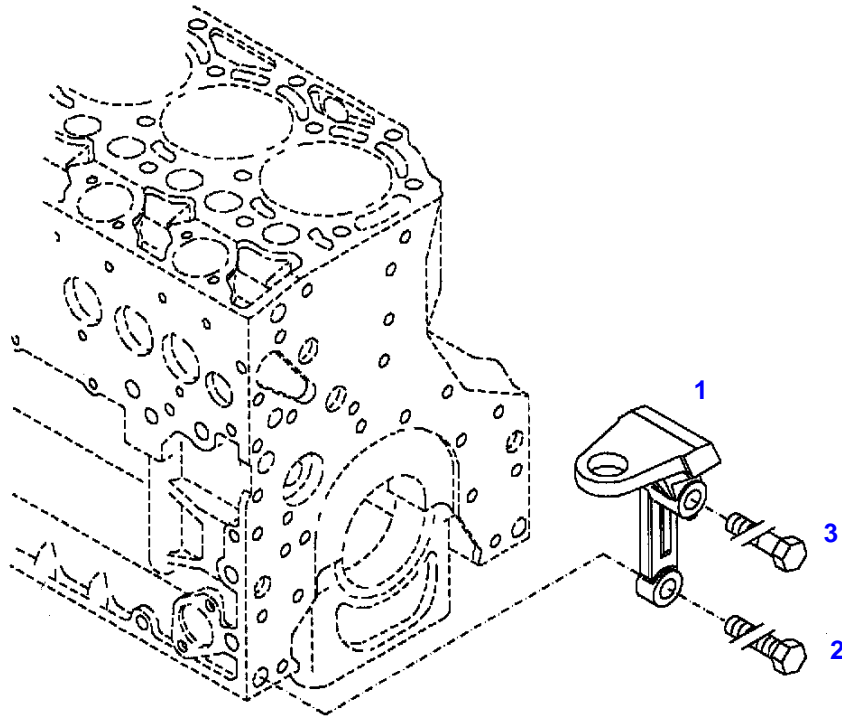

040030

Fendt

FARMER 409 (409/00101-99999)

F409000

ENGINE MOUNTINGS

Page01-0015

Item	Part Number	Qty	Description Comments	Technical Specification
			RIGHT	
1	72423955	1	ENGINE SUSPENSION	
2	72418408	1	HEXAGONAL HEAD BOLT	DIN 933 M16X40 GWA-10.9
3	72374294	1	HEXAGONAL HEAD BOLT	DIN 931-M16X85 GWA-10.9

FARMER 409 (409/00101-99999)
35107

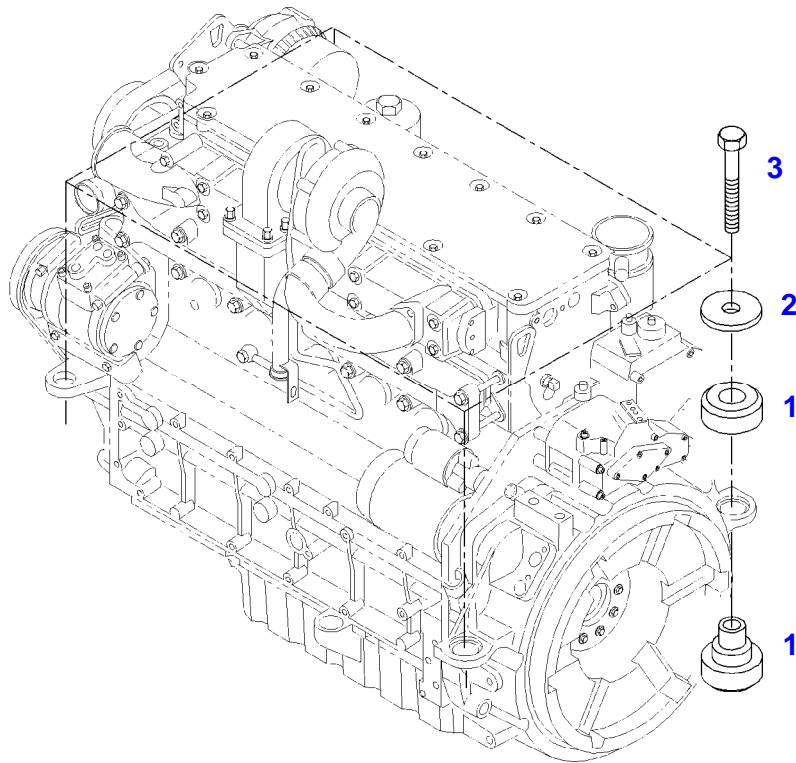

035107

Fendt

FARMER 409 (409/00101-99999)

F409000

ENGINE BEARINGS

Page01-0016

Item	Part Number	Qty	Description Comments	Technical Specification
1	72423988	4	ENGINE MOUNT	
2	72318110	4	DISC	
3	72315563	4	HEXAGONAL HEAD BOLT	DIN 931 M12X80-8.8A3L

FARMER 409 (409/00101-99999)
36448

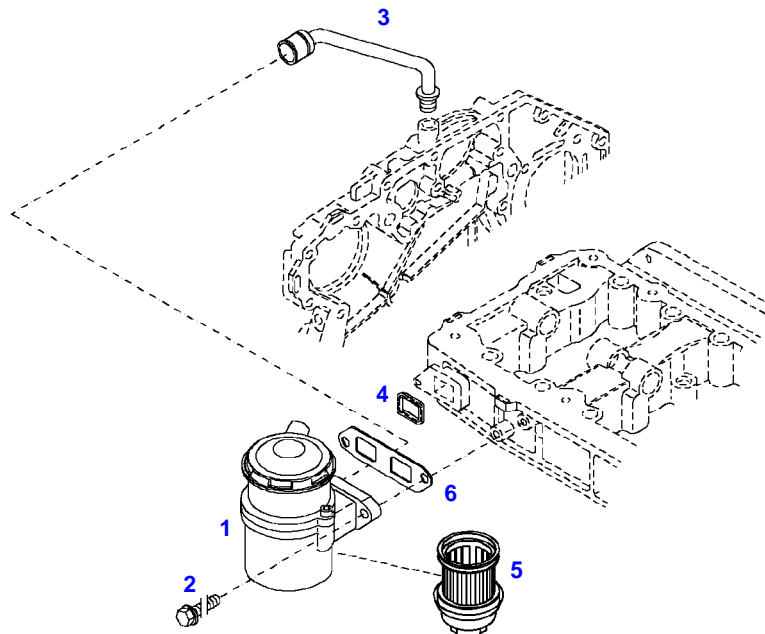

036448

Item	Part Number	Qty	Description Comments	Technical Specification
			ENGINE NUMBER --> 673449	
1	72416476	1	BREATHER ><4,5	
2	72325449	2	HEXAGONAL HEAD BOLT M8X25	M8X25
3	72416477	1	RUBBER-JACKET CORD	
4	72416500	1	MOLDED SEAL	
5	72416501	1	FILTER ELEMENT	
6			NOT USED	

FARMER 409 (409/00101-99999)
12566

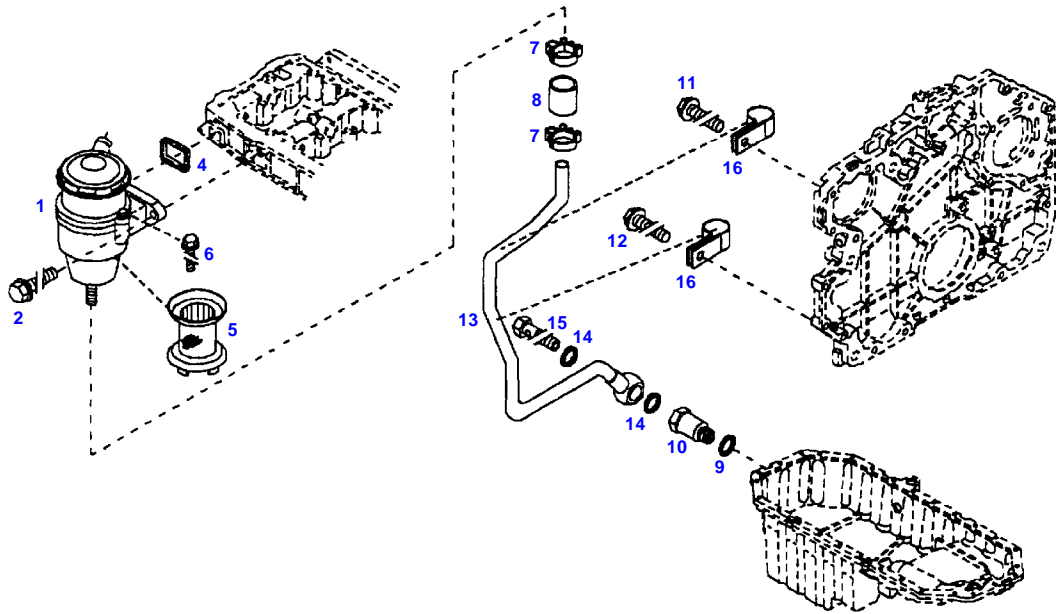

12566

Item	Part Number	Qty	Description Comments	Technical Specification
			ENGINE NUMBER <-- 673450 --> 409/3097	
1	72425784	1	BREATHER ><4-6 <-- F718.202.210.130	
2	72325449	2	HEXAGONAL HEAD BOLT M8X25	M8X25
4	72416500	1	MOLDED SEAL	
5	72425767	1	FILTER ELEMENT	
6	72425768	2	HEXAGONAL HEAD BOLT M5X20	
7	72325537	2	HOSE CLIP	
8	72425769	1	THIMBLE	
9	72315101	1	SEALING WASHER	DIN 7603 A22X27-CU
10	72425770	1	LOCK VALVE	
11	72325453	1	HEXAGONAL HEAD BOLT M8X50	
12	72325457	1	HEXAGONAL HEAD BOLT M8X40	
13	72425771	1	BREATHER LINE ><14-16	
14	72416578	2	SEALING WASHER	
15	72323517	1	BANJO BOLT	
16	72425772	2	PIPE CLAMP	

FARMER 409 (409/00101-99999)
12566

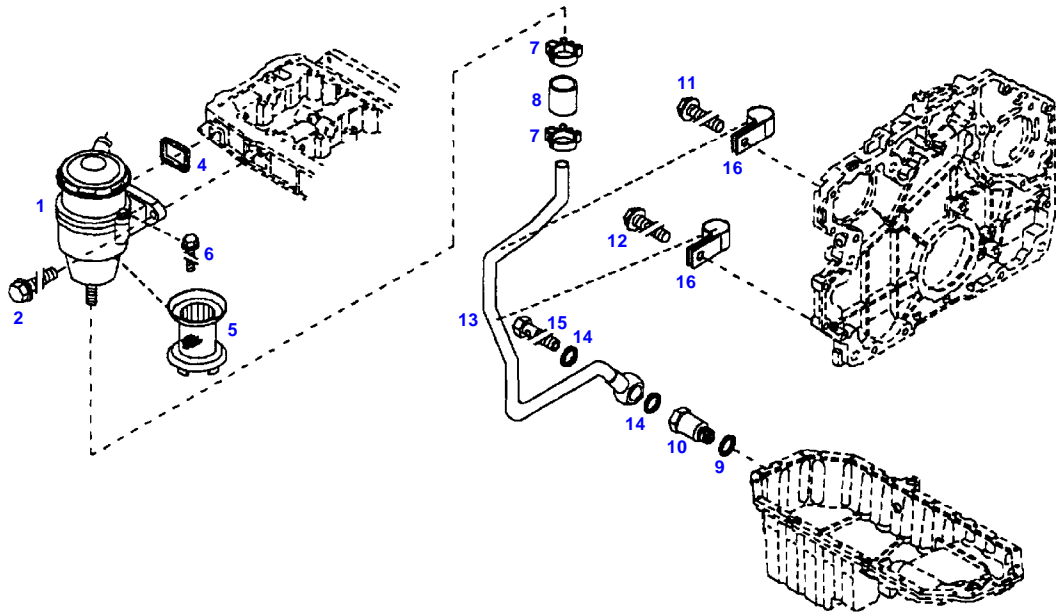

12566

Item	Part Number	Qty	Description Comments	Technical Specification
			<-- 409/3098	
1	72426699	1	BREATHER ><4-6 ENG.NO. --> 1001259 <-- F718.202.210.130	
	72434609	1	BREATHER WITHOUT SERVICEABLE FILTER ><4,6 <-- 1001260	
2	72325449	2	HEXAGONAL HEAD BOLT M8X25	M8X25
4	72416500	1	MOLDED SEAL	
5	72426653	1	FILTER ELEMENT ENG.NO. --> 1001259	
			NOT AVAILABLE IN SINGLE PARTS ENG.NO. <-- 1001260	
6	72425768	2	HEXAGONAL HEAD BOLT M5X20	
7	72325537	2	HOSE CLIP	
8	72425769	1	THIMBLE	
9	72315101	1	SEALING WASHER	DIN 7603 A22X27-CU
10	72425770	1	LOCK VALVE	
11	72325453	1	HEXAGONAL HEAD BOLT M8X50	
12	72325457	1	HEXAGONAL HEAD BOLT M8X40	
13	72425771	1	BREATHER LINE ><14-16	
14	72416578	2	SEALING WASHER	
15	72323517	1	BANJO BOLT	
16	72425772	2	PIPE CLAMP	

FARMER 409 (409/00101-99999)
30820

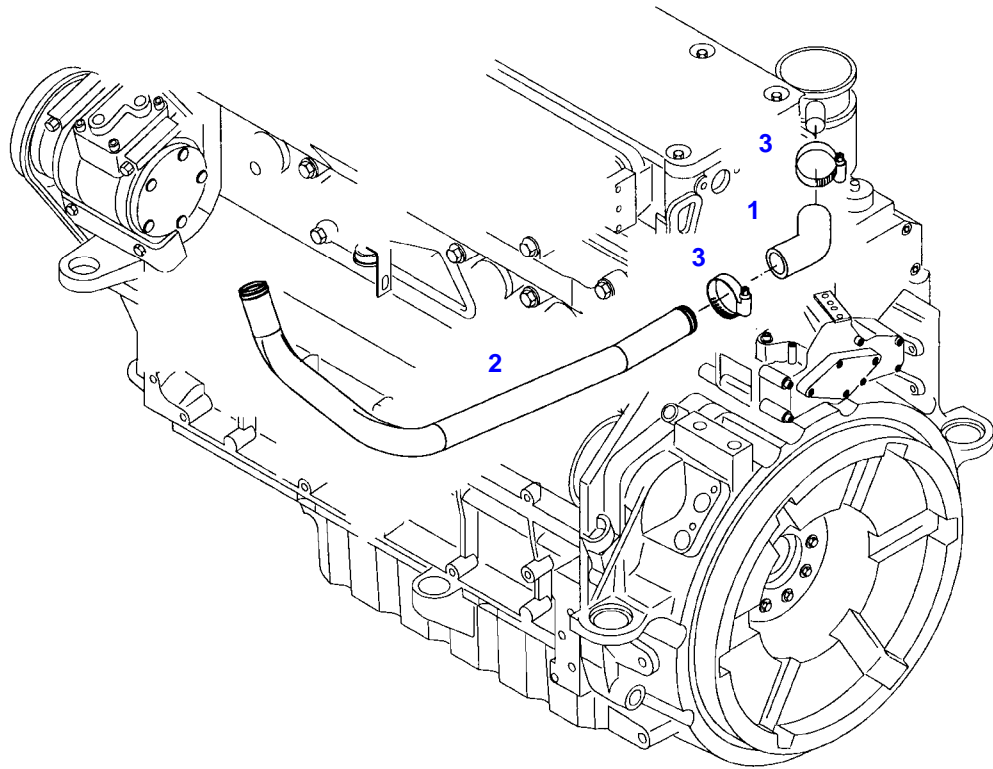

030820

Fendt

FARMER 409 (409/00101-99999)

F409000

CRANKCASE BREATHER

Page01-0020

Item	Part Number	Qty	Description Comments
			PIPE
1	72318111	1	RUBBER ARCH
2	72424489	1	PIPE
3	72311167	2	HOSE CLIP

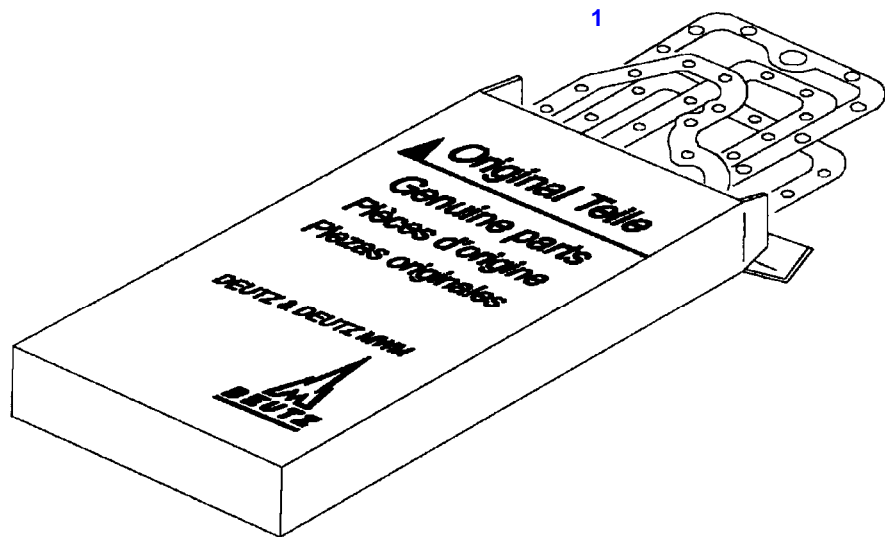

030100



Suggest:

For more complete manuals. Please go to the home page.

<https://www.ebooklibonline.com>

If the above button click is invalid. Please download this document first, and then click the above link to download the complete manual.

Thank you so much for reading

Item	Part Number	Qty	Description Comments
			ENGINE
1	72487661	1	SEAL KIT WITHOUT CYLINDER HEAD GASKET FOR VALVE COVER ALUMINIUM ENG.NO. --> 560367
	72487667	1	SEAL KIT WITHOUT CYLINDER HEAD GASKET FOR VALVE COVER PLASTIC ENG.NO. <-- 560368

FARMER 409 (409/00101-99999)
40475

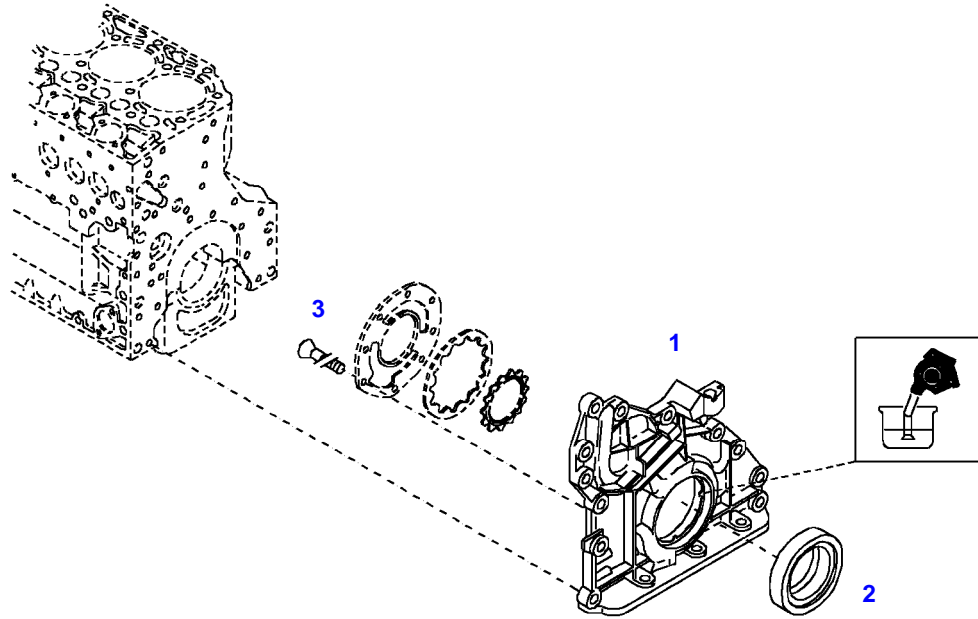

040475

<https://www.ebooklibonline.com>

Hello dear friend!

Thank you very much for reading.

Enter the link into your browser.

The full manual is available for immediate download.

<https://www.ebooklibonline.com>