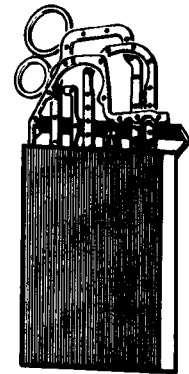
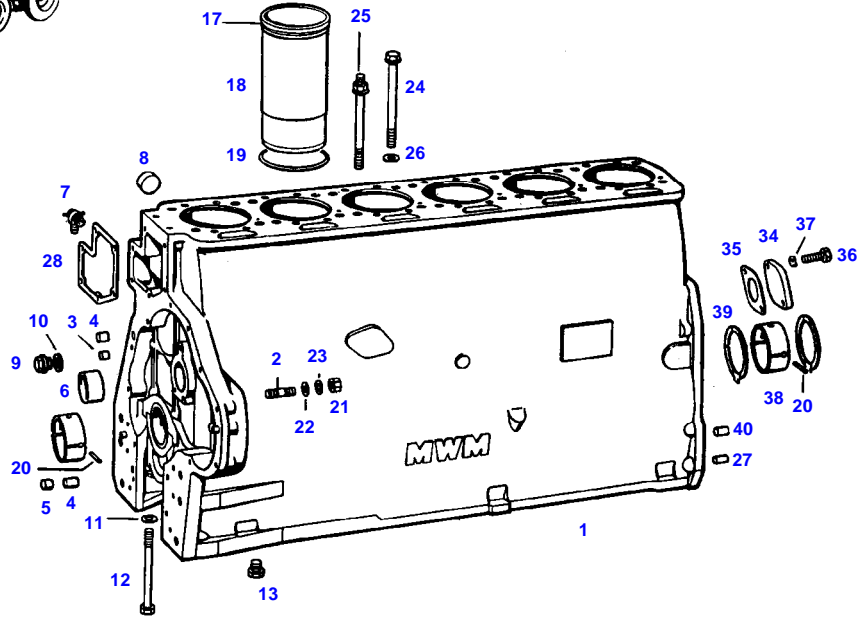

TABLE OF CONTENT

Page Number	Page Title	Page Reference
01-000-TOC	ENGINE, FUEL AND EXHAUST SYSTEM	01-000-TOC
02-000-TOC	AXLES	02-000-TOC
03-000-TOC	STEERING SYSTEM	03-000-TOC
04-000-TOC	DRIVE TRAIN SYSTEM	04-000-TOC
05-000-TOC	COMPRESSED AIR SYSTEM	05-000-TOC
06-000-TOC	HYDRAULIC SYSTEM	06-000-TOC
07-000-TOC	ELECTRICAL SYSTEM	07-000-TOC
08-000-TOC	CAB	08-000-TOC
09-000-TOC	AIR CONDITIONING AND HEATING SYSTEM	09-000-TOC
10-000-TOC	CHASSIS	10-000-TOC
11-000-TOC	WHEELS	11-000-TOC
12-000-TOC	IMPLEMENT LIFT SYSTEM FRONT	12-000-TOC
13-000-TOC	IMPLEMENT LIFT SYSTEM REAR	13-000-TOC
14-000-TOC	FRONT/REAR LOADERS	14-000-TOC
15-000-TOC	ACCESSORIES	15-000-TOC

FARMER 311 (198/05001-07700)
4685



4685

Item	Part Number	Qty	Description Comments	Technical Specification
	72431088	1	DIESEL ENGINE	
1	72332981	1	CRANKCASE ><1-13,20-23	
2	72313777	4	STUD BOLT	DIN 939 M10X35-8.8
3	72327772	9	PLUG 10 MM	
4	72327773	3	PLUG 14 MM	
5	72327068	2	PLUG 16 MM	
6	72329540	1	BUSH	
7	72378063	1	RELIEF VALVE	DIN71401-CM14X1,5KEG
8	72377226	5	COVER	DIN 443-50
9	72315436	1	SCREW	DIN 908 M10X1-ST A3L
10	72315088	1	SEALING WASHER	DIN 7603 A10X13,5-CU
11	72324592	14	DISC	
12	72327081	14	HEXAGONAL HEAD BOLT	
13	72373972	1	PLUG	DIN 910 M16X1,5-ST
17	72329541	12	SEAL	
18	72425044	6	CYLINDER LINER	
19	72343893	12	SEAL	
20	72375130	7	TENSIONING PIN	ISO8752-4X8-A-ST-ZNPH
21	72372810	4	NUT	DIN 934 M10-10
22	72311789	4	DISC	DIN 125-10,5-ST.A3L
23	72375420	4	TOOTHLOCK WASHER	DIN 6797 A10,5
24	72333013	22	SOCKET HEAD BOLT MUST NOT BE RETIGHTENED	
25	72333014	2	HEXAGONAL HEAD BOLT MUST NOT BE RETIGHTENED	
26	72324592	24	DISC	
27	72313859	4	CYLINDER PIN	DIN 7-8M6X18-ST50K
28	72327043	1	MOLDED SEAL	
34	72343896	1	COVER	
35	72333001	1	SEAL	
36	72315650	2	HEXAGONAL HEAD BOLT	DIN 933 M8 X 20-8.8A3L
37	72315053	2	SPLIT WASHER	FWN 65208-8-A3L
38	72341078	7	MAIN BEARING 70,00 MM	
	72341079	7	MAIN BEARING 69,79 MM	
	72341080	7	MAIN BEARING 69,54 MM	
	72341081	7	MAIN BEARING 69,29 MM	
	72341082	7	MAIN BEARING 69,04 MM	
39	72343910	2	THRUST RING 70,00 MM	
	72343911	2	THRUST RING 69,79 MM	
	72343912	2	THRUST RING 69,54 MM	
	72343913	2	THRUST RING 69,04 MM	
40	72375324	2	CYLINDER PIN	DIN 7-10M6X28-ST50K
41	72376240	1	SEAL KIT D 226 B-6	D226B-6

<https://www.ebooklibonline.com>

Hello dear friend!

Thank you very much for reading.

Enter the link into your browser.

The full manual is available for immediate download.

<https://www.ebooklibonline.com>

Item	Part Number	Qty	Description Comments	Technical Specification
1	72343896	1	COVER	
2	72376544	1	O-RING	42,2X3-NBR 70 FWN56402
3	72315650	2	HEXAGONAL HEAD BOLT	DIN 933 M8 X 20-8.8A3L
4	72317121	2	SPRING WASHER	DIN 137 B8-MECH.VZK
5	72340126	1	CRANKCASE END COVER	
6	72332982	1	RADIAL SEALING RING	
7	72326907	1	HOUSING	
8	72376514	1	O-RING	32X4-NBR 70 FWN56402
9	72326906	1	THREADED PIN	
10	72326904	1	COVER PANEL	
11	72372804	2	NUT	DIN 934 M6-10
12	72330757	1	MOLDED SEAL	
13	72315660	1	HEXAGONAL HEAD BOLT	DIN 933 M8X35-8.8A3L
14	72374372	7	HEXAGONAL HEAD BOLT	DIN 931 M8X45S-8.8
15	72315534	5	HEXAGONAL HEAD BOLT	DIN 931 M8 X 70-8.8
16	72315053	13	SPLIT WASHER	FWN 65208-8-A3L
17	72321607	1	PLUG	
18	72315087	1	SEALING WASHER	DIN 7603 A8X14-CU
19	72315644	1	HEXAGONAL HEAD BOLT	DIN 933 M8X10-8.8A3L
20	72376538	1	O-RING	40X4
28	72436284	1	HOSE 1X 830MM CUT TO LENGTH	L=1120 FWN65912-19X3-PVC-W-G
29	72311166	1	HOSE CLIP	
30	72407980	1	COMPRESSION SPRING	
31	72312910	1	DECAL	

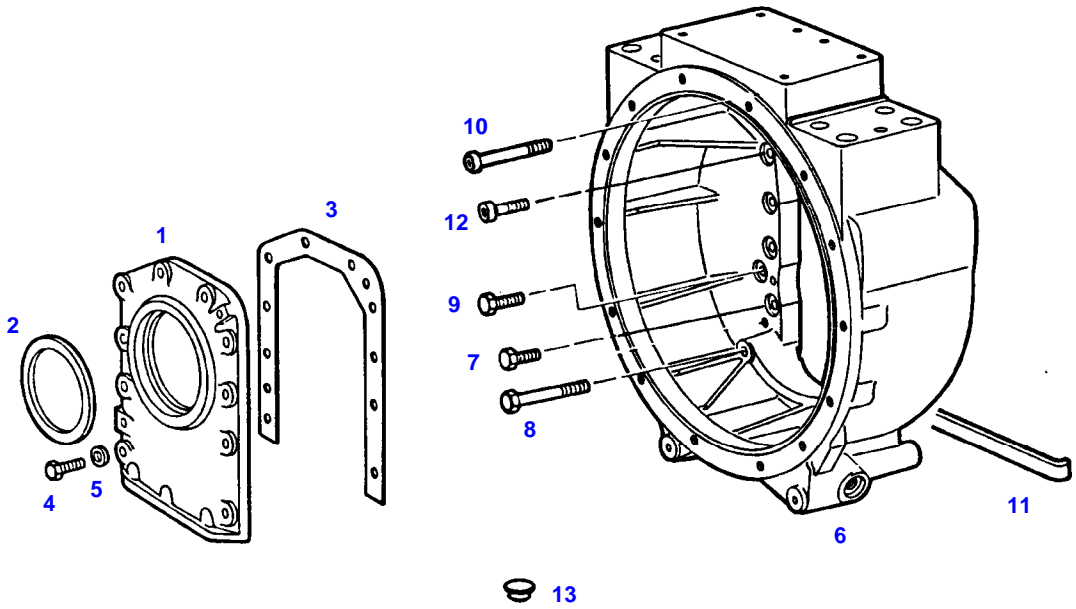

4687

Item	Part Number	Qty	Description Comments	Technical Specification
1	72330754	1	CRANKCASE END COVER >>2	
2	72376834	1	SHAFT SEAL	110X130X14,5
3	72330755	1	MOLDED SEAL	
4	72315759	10	HEXAGONAL HEAD BOLT	DIN 933 M8X25 SK-8.8
5	72317121	10	SPRING WASHER	DIN 137 B8-MECH.VZK
6	72397268	1	HOUSING <> X487 531 800 10X <>	
	72374220	4	HEXAGONAL HEAD BOLT	DIN 931-M12X80-12.9
	72315686	10	HEXAGONAL HEAD BOLT	DIN 933-M10X35-12.9
	72374189	2	HEXAGONAL HEAD BOLT	DIN 931 M10X85-12.9
	72374073	4	SOCKET HEAD BOLT	DIN 912 M12X45-12.9
7	72374435	10	HEXAGONAL HEAD BOLT	DIN933 M10X33 GWA-10.9
8	72374189	2	HEXAGONAL HEAD BOLT	DIN 931 M10X85-12.9
9	72315713	3	HEXAGONAL HEAD BOLT	DIN 933 M12X40 GWA-10.9
10	72374080	2	SOCKET HEAD BOLT	DIN 912 M12X75-12.9
11	72325584	1	RUBBER STRIP	
12	72374074	3	SOCKET HEAD BOLT	DIN 912 M12X50-12.9
13	72375092	6	LOCKING PLUG F12	V14
	72375075	1	LOCKING PLUG F3	F3
	72314748	4	LOCKING PLUG F11	SW-F11
	72314763	4	LOCKING PLUG F211	F211

FARMER 311 (198/05001-07700)
4690

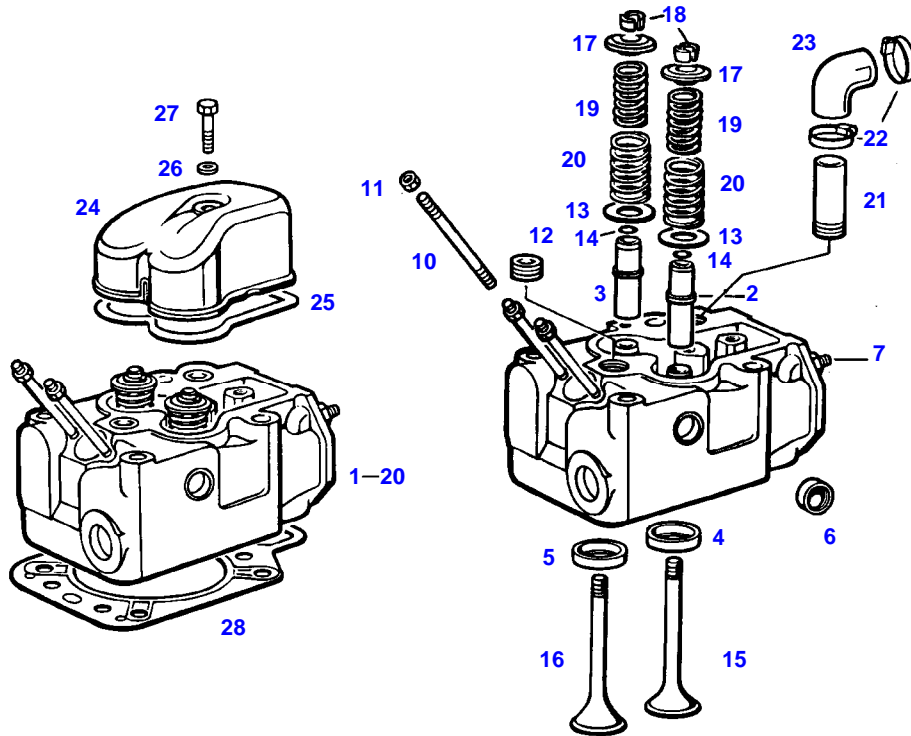

4690

Item	Part Number	Qty	Description Comments	Technical Specification
1	72332983	6	CYLINDER HEAD ><2-20	
2	72343644	6	VALVE GUIDE ><14 INTAKE	
3	72343645	6	VALVE GUIDE ><14 OUTLET	
4	72332986	6	VALVE SEAT RING INTAKE	
5	72343902	6	VALVE SEAT RING OUTLET	
6	72311455	24	COVER	
7			SEE AIRFILTER	
10	72374627	12	STUD BOLT	DIN 939 M8X40-8.8
11	72313268	12	NUT	DIN 934 M8-8A3L
12	72373948	6	PLUG SCREW	DIN 906 M22X1,5-ST
13	72340915	12	DISC	
14	72343647	12	SEAL	
15	72332984	6	INLET VALVE CONE	
16	72332985	6	OUTLET VALVE CONE	
17	72327093	12	SPRING RETAINER	
18	72327092	24	TAPER PIECE HALF	
19	72340914	12	VALVE SPRING	
20	72340913	12	VALVE SPRING	
21	72397409	1	PIPE PIECE	
22	72311167	12	HOSE CLIP	
23	72332971	6	RUBBER ARCH	
24	72343906	6	CYLINDER HEAD COVER	
25	72343908	6	MOLDED SEAL	
26	72315087	6	SEALING WASHER	DIN 7603 A8X14-CU
27	72315659	6	HEXAGONAL HEAD BOLT	DIN 933 M8X35-8.8
28	72343992	6	CYLINDER HEAD GASKET	

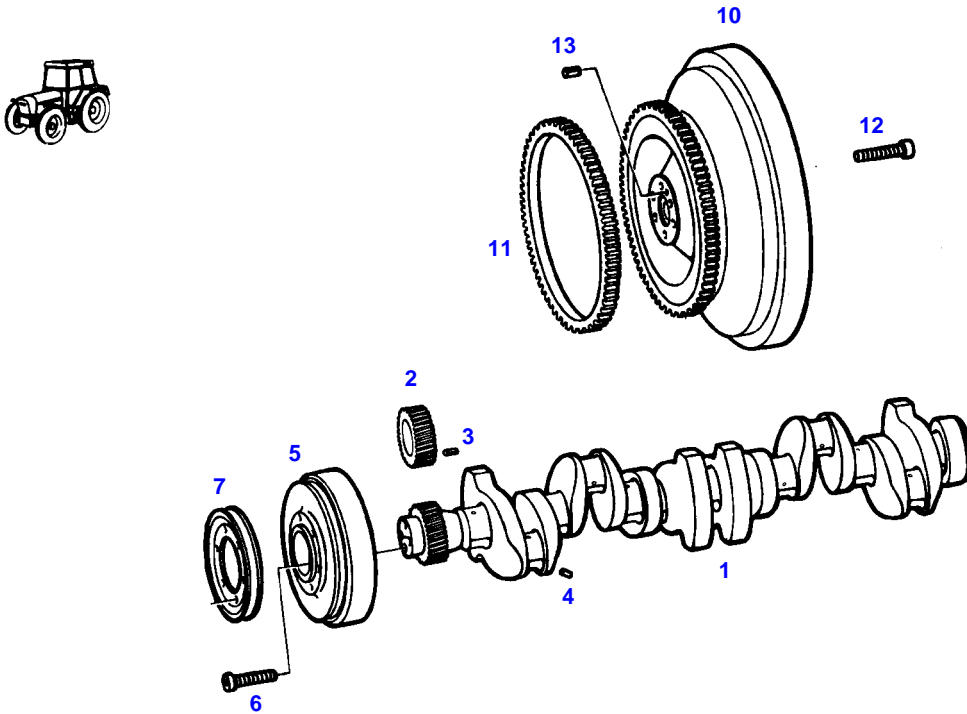

4688

Item	Part Number	Qty	Description Comments	Technical Specification
1	72332581	1	CRANKSHAFT ><2-4 <-- F312.200.310.010 1X	
2	72341105	1	SPUR GEAR	
3	72375132	1	TENSIONING PIN	ISO8752-4X18-A-ST-ZNPHR10F-KOE
4	72337059	6	PLUG	
5	72332582	1	VIBRATION DAMPER	
6	72374113	4	SOCKET HEAD BOLT	DIN 912 M16X50-10.9
7			SEE V-BELT	
10	72332583	1	FLYWHEEL ><11	
11	72330772	1	RING GEAR	
12	72315739	6	HEXAGONAL HEAD BOLT	DIN 933 M16X60 GWA-10.9
13	72375149	1	TENSIONING PIN	ISO8752-6X10-A-ST

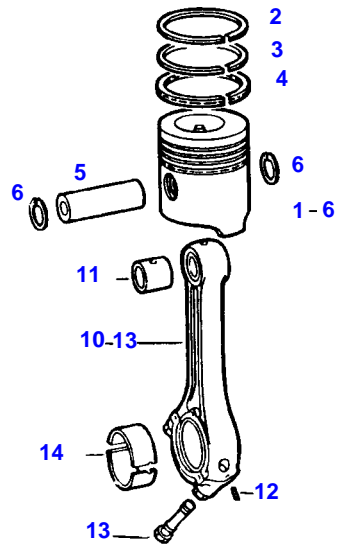

3119

Item	Part Number	Qty	Description Comments	Technical Specification
1	72332988	6	PISTON ><1-6	
2	72333027	6	PISTON RING KIT ><2-4	
5			NOT AVAILABLE IN SINGLE PARTS	
6	72332584	12	LOCKWASHER	
10	72343926	6	PISTON ROD ><10-13	
11	72341118	6	SMALL-END BUSH	
12	72313802	6	TENSIONING PIN	ISO8752-4X16-A-ST-ZNPHR10F-KOE
13	72327143	12	CONNECTING ROD BOLT	
14	72341119	6	CONNECTING ROD BEARING 63,00 MM	
	72341120	6	CONNECTING ROD BEARING 62,75 MM	
	72341121	6	CONNECTING ROD BEARING 62,50 MM	
	72341122	6	CONNECTING ROD BEARING 62,25 MM	
	72341123	6	CONNECTING ROD BEARING 62,00 MM	

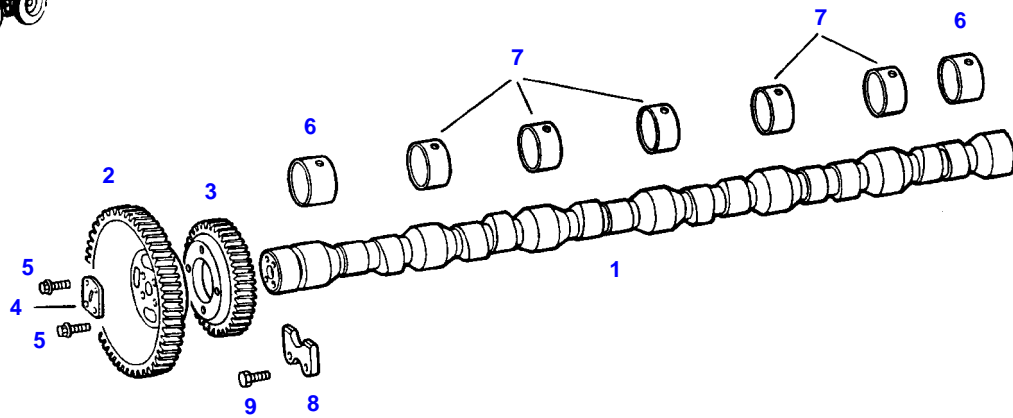

4689

Item	Part Number	Qty	Description Comments	Technical Specification
1	72333000	1	CAMSHAFT	
2	72343928	1	SPUR GEAR	
3	72343929	1	SPUR GEAR	
4	72331325	1	PROFILED FLANGE	
5	72375063	8	LOCK SCREW	FWN 64993 M8X22-12.9
6	72332989	2	BUSH REPAIR STEP	
7	72332990	5	BUSH REPAIR STEP	
8	72343930	1	SEGMENT	
9	72375061	2	LOCK SCREW	W151.12 M8X16-90

FARMER 311 (198/05001-07700)
3121

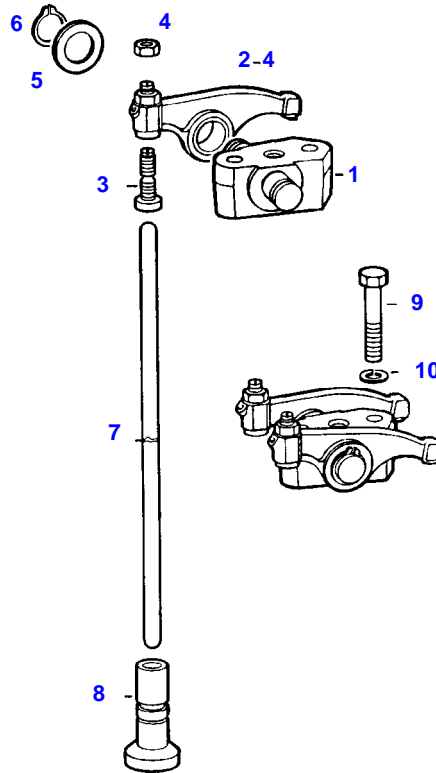

3121

Item	Part Number	Qty	Description Comments	Technical Specification
1	72343933	6	ROCKER ARM SUPPORT	
2	72343934	12	ROCKER ARM ><3+4	
3	72343935	12	ADJUSTING SCREW	
4	72343936	12	NUT	
5	72321237	24	DISC	
6	72375559	12	LOCK WASHER	DIN 471-16X1
7	72330785	12	BUMPER	
8	72343937	12	MUSHROOM TAPPET	
	72423816	12	MUSHROOM TAPPET OVERSIZE 19,5 MM	
9	72315691	12	HEXAGONAL HEAD BOLT	DIN 933 M10X40-8.8A3L
10	72315054	12	SPLIT WASHER	FWN 65208-10-A3L

FARMER 311 (198/05001-07700)
3124

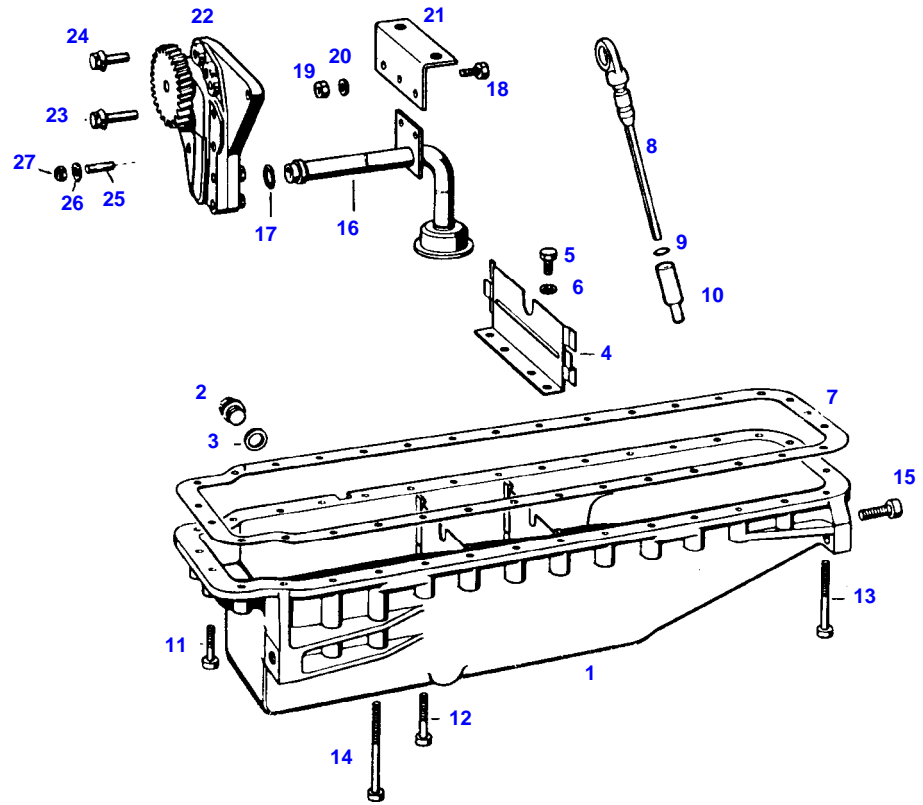

3124

Item	Part Number	Qty	Description Comments	Technical Specification
1	72332579	1	OIL PAN ><2-6	
2	72373986	1	SCREW	
3	72332580	1	SEALING WASHER	
4	72340912	2	WASHER PLATE	
5	72374587	4	HEXAGONAL HEAD BOLT	DIN 933 M8X12 SZ-8.8
6	72315053	4	SPLIT WASHER	FWN 65208-8-A3L
7	72340911	1	MOLDED SEAL	
8	72343547	1	DIPSTICK ><9	
9	72376384	1	O-RING	7,3X2,4
10	72326139	1	PIPE PIECE	
11	72374024	7	SOCKET HEAD BOLT	DIN 912-M8X45-10.9
12	72315484	18	SOCKET HEAD BOLT	DIN 912 M8X65-10.9A3L
13	72374032	2	SOCKET HEAD BOLT	DIN 912 M8X100-10.9
14	72374038	6	SOCKET HEAD BOLT	DIN 912 M8X140-10.9
15	72315511	4	SOCKET HEAD BOLT	DIN 912 M12X40-10.9
16	72340916	1	LUBE OIL LINE	
17	72376491	1	O-RING 25X4	25X4-FPM 70 FWN56402
	72376462	1	O-RING 20X4	20X4-FPM 70 FWN56402
18	72315642	2	HEXAGONAL HEAD BOLT	DIN 933 M8 X 16-8.8A3L
19	72313268	2	NUT	DIN 934 M8-8A3L
20	72315053	2	SPLIT WASHER	FWN 65208-8-A3L
21	72330779	1	GUSSET PLATE	
22	72332187	1	OIL GEAR PUMP	
23	72375067	1	LOCK SCREW	FWN 64993 M8X35-90
24	72375063	1	LOCK SCREW	FWN 64993 M8X22-12.9
25	72374623	1	STUD BOLT	DIN 939-M8X25-8.8
26	72340920	1	DISC	
27	72340921	1	MIDGRIP NUT	

FARMER 311 (198/05001-07700)
4565

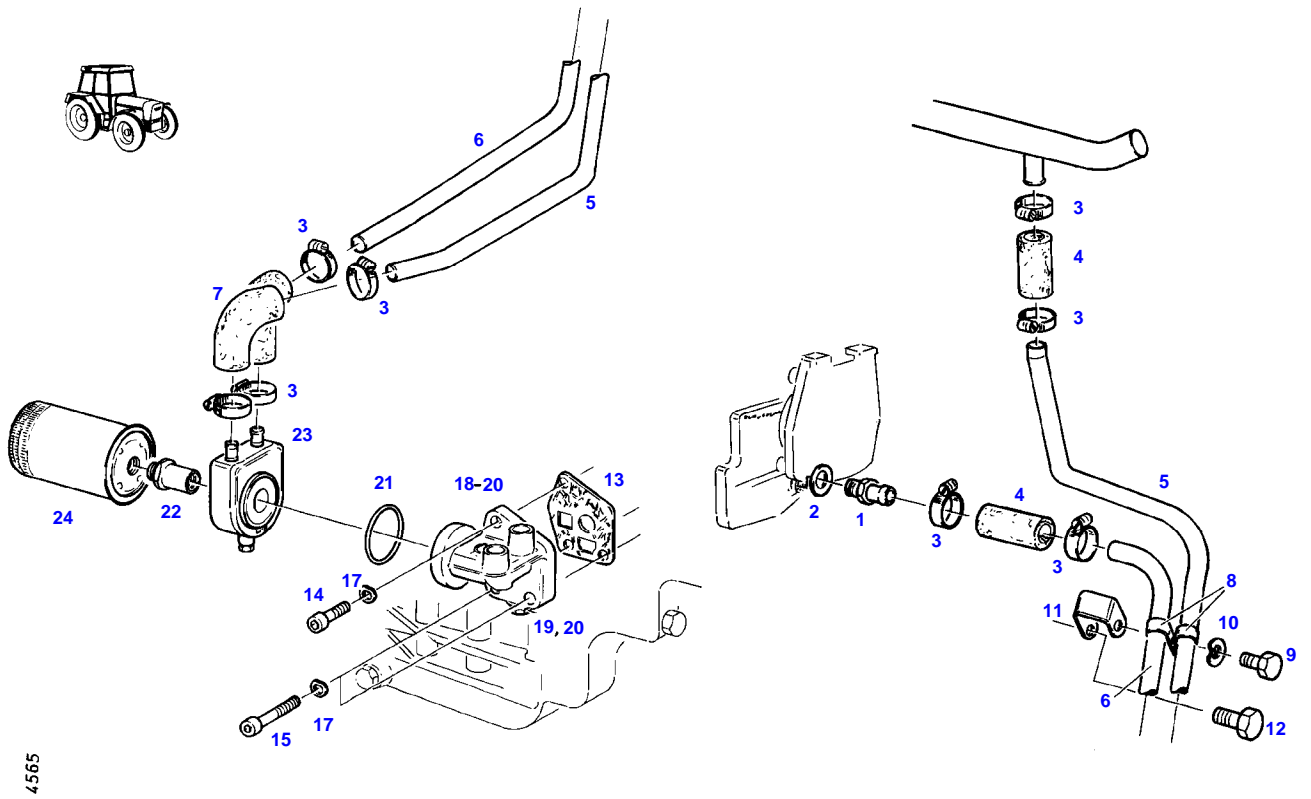

4565

Item	Part Number	Qty	Description Comments	Technical Specification
1	72396595	1	HOSE BARB	
2	72315101	1	SEALING WASHER	DIN 7603 A22X27-CU
3	72311167	8	HOSE CLIP	
4	72396335	2	HOSE PIECE	
5	72397288	1	COOLANT LINE --> 199/2199	
6	72396332	1	COOLANT LINE	
7	72435869	2	RUBBER ARCH	
8	72386726	2	PIPE CLAMP	
9	72315675	1	HEXAGONAL HEAD BOLT	DIN 933 M10X16-8.8A3L
10	72317122	1	SPRING WASHER	DIN 137 B10-MECH.VZK
11	72397289	1	RETAINER	
12	72315704	1	HEXAGONAL HEAD BOLT	DIN 933 M12X16-8.8A3L
13	72327148	1	MOLDED SEAL	
14	72315494	1	SOCKET HEAD BOLT	DIN 912 M10X30-8.8
15	72315498	2	SOCKET HEAD BOLT	DIN 912 M10X40-8.8 OB1-SW
17	72317122	3	SPRING WASHER	DIN 137 B10-MECH.VZK
18	72325601	1	FILTER HEAD ><18-20 <-- G510.201.900.100	
19	72325606	1	VALVE	
20	72376031	1	SEALING WASHER	DIN 7603 A20X24-CU
21	72396334	1	O-RING	
22	72396333	1	SCREW PIECE	
23	72348781	1	OIL COOLER <>	
	72327148	1	MOLDED SEAL	
	72315797	1	PLUG SCREW	DIN 7604 AM10X1-ST A3L
	72315088	1	SEALING WASHER	DIN 7603 A10X13,5-CU
24	72334900	1	OIL FILTER	

FARMER 311 (198/05001-07700)
4695

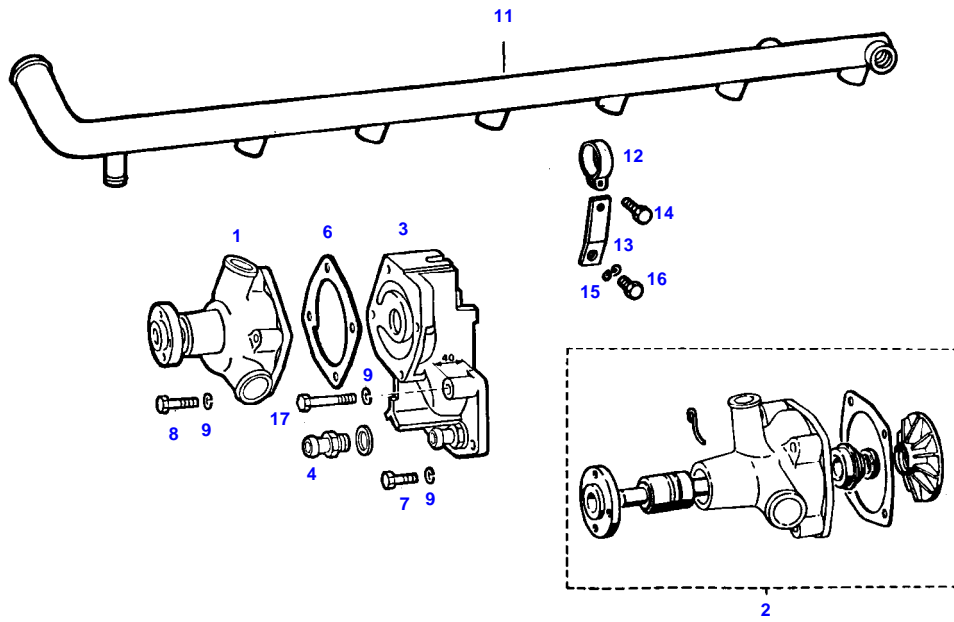

4695

Item	Part Number	Qty	Description Comments	Technical Specification
1	72340133	1	CENTRIFUGAL PUMP	
	72343555	1	CENTRIFUGAL PUMP AIR CONDITION	
2	72340135	1	REPAIR KIT <-- F281 200 610 010 NO SPARE PART	
	72343940	1	REPAIR KIT AIR CONDITION	
3	72332991	1	INTERMEDIATE PIECE	
4			SEE OIL COOLER	
6	72328678	1	SEAL	
7	72315653	4	HEXAGONAL HEAD BOLT	DIN 933 M8 X 25-8.8A3L
8	72315659	4	HEXAGONAL HEAD BOLT	DIN 933 M8X35-8.8
9	72315053	10	SPLIT WASHER	FWN 65208-8-A3L
11	72332992	1	COOLANT LINE	
12	72332993	2	PIPE CLAMP	
13	72332994	2	PLATE LINK	
14	72315630	2	HEXAGONAL HEAD BOLT	DIN 933 M6X18-8.8A3L
15	72315052	2	SPLIT WASHER	FWN 65208-6-A3L
16	72315462	2	SOCKET HEAD BOLT	DIN 912 M6X12-8.8A3L
17	72374429	2	HEXAGONAL HEAD BOLT	DIN 933 M8X55-8.8

FARMER 311 (198/05001-07700)
4586

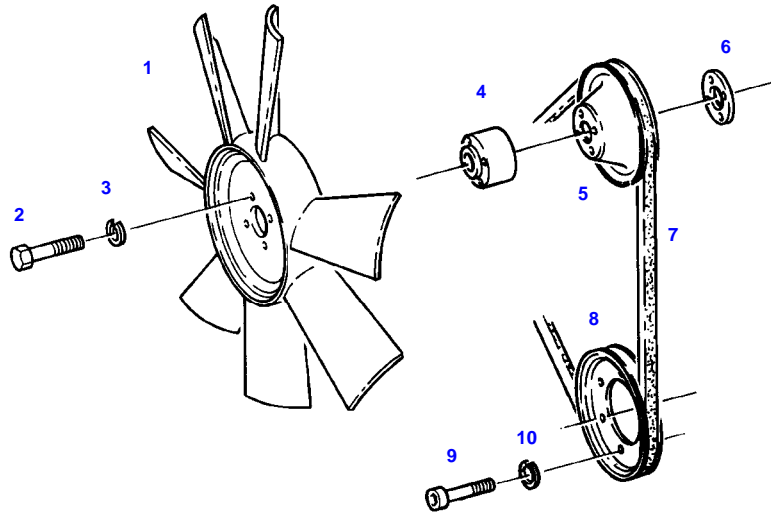

4586

Item	Part Number	Qty	Description Comments	Technical Specification
			RANGE OF TEMPERATURE 1	
1	72357743	1	FAN <>	
	72313268	4	NUT	DIN 934 M8-8A3L
	72393710	1	FLANGE	
	72315646	4	HEXAGONAL HEAD BOLT	DIN 933 M8X18-8.8A3L
	72315053	4	SPLIT WASHER	FWN 65208-8-A3L
2	72315668	4	HEXAGONAL HEAD BOLT	DIN 933 M8X50-8.8A3L
3	72315053	4	SPLIT WASHER	FWN 65208-8-A3L
4	72397273	1	RING	
5	72330787	1	V BELT SHEAVE	
6			NOT USED	
7	72379382	1	V-BELT	FWN66966-AVX10X1310LA
8	72337036	1	V BELT SHEAVE	
9	72374044	6	SOCKET HEAD BOLT	DIN 912 M10X16-10.9
10	72315054	6	SPLIT WASHER	FWN 65208-10-A3L

FARMER 311 (198/05001-07700)
4586

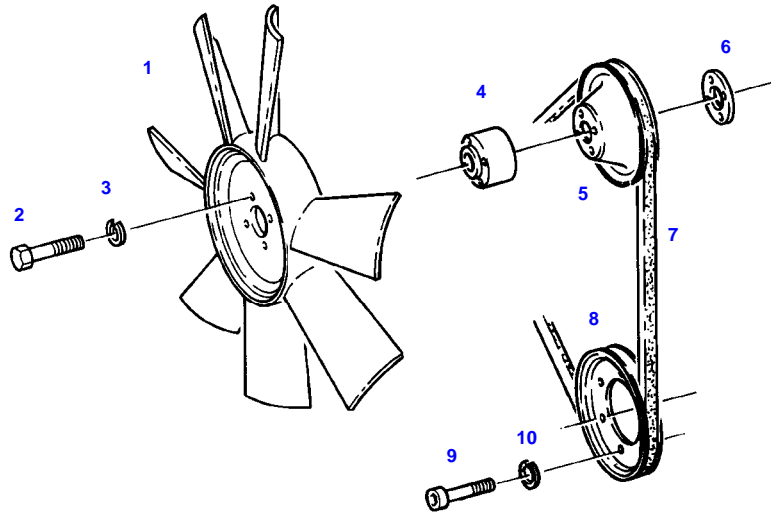

4586

Item	Part Number	Qty	Description Comments	Technical Specification
RANGE OF TEMPERATURE 2				
1	72357743	1	FAN	
			<>	
	72315646	4	HEXAGONAL HEAD BOLT	DIN 933 M8X18-8.8A3L
	72313268	4	NUT	DIN 934 M8-8A3L
	72393710	1	FLANGE	
	72315053	4	SPLIT WASHER	FWN 65208-8-A3L
2	72315669	4	HEXAGONAL HEAD BOLT	DIN 933 M8X55-8.8A3L
3	72315053	4	SPLIT WASHER	FWN 65208-8-A3L
4	72399875	1	INTERMEDIATE RING	
5	72399923	1	V BELT SHEAVE	
6			NOT USED	
7	72379427	1	V-BELT	FWN66966-AVX10X1275LA
8	72337036	1	V BELT SHEAVE	
9	72374044	6	SOCKET HEAD BOLT	DIN 912 M10X16-10.9
10	72315054	6	SPLIT WASHER	FWN 65208-10-A3L

FARMER 311 (198/05001-07700)
4587

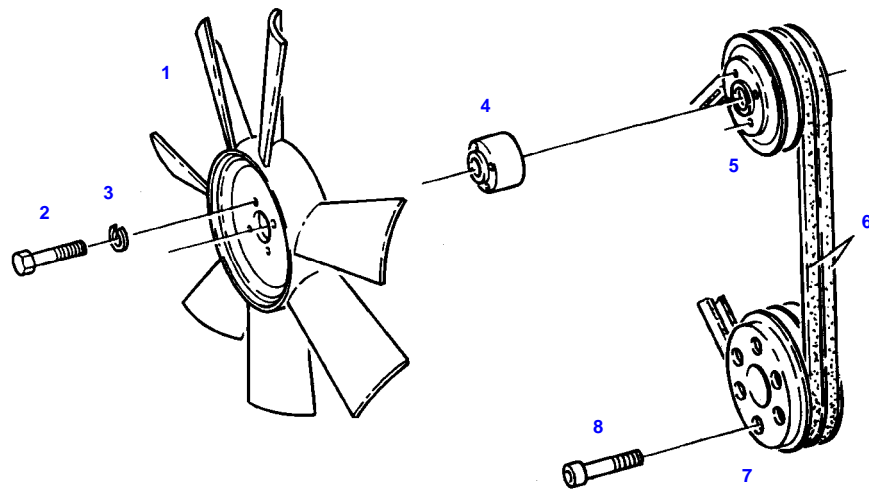

4587

Item	Part Number	Qty	Description Comments	Technical Specification
			RANGE OF TEMPERATURE 1+2 WITH AIR CONDITION	
1	72357743	1	FAN <>	
	72393710	1	FLANGE	
	72313268	4	NUT	DIN 934 M8-8A3L
	72315646	4	HEXAGONAL HEAD BOLT	DIN 933 M8X18-8.8A3L
	72315053	4	SPLIT WASHER	FWN 65208-8-A3L
2	72315668	4	HEXAGONAL HEAD BOLT	DIN 933 M8X50-8.8A3L
3	72315053	4	SPLIT WASHER	FWN 65208-8-A3L
4	72399875	1	INTERMEDIATE RING	
5	72397274	1	V BELT SHEAVE	
6	72379380	1	V-BELT SET (2 PIECE)	FWN66966-2XAVX10X1310LA
7	72396002	1	V BELT SHEAVE	
8	72315498	6	SOCKET HEAD BOLT	DIN 912 M10X40-8.8 OB1-SW

FARMER 311 (198/05001-07700)
4588

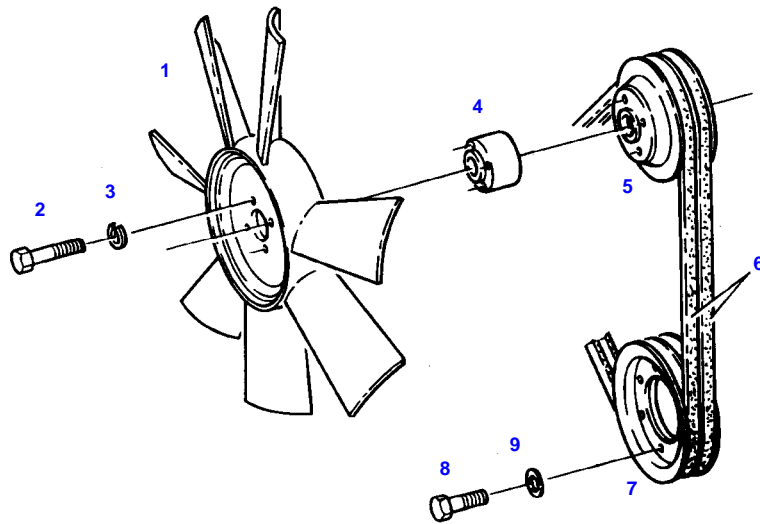

4588

Item	Part Number	Qty	Description Comments	Technical Specification
			RANGE OF TEMPERATURE 1+2 WITH AIR BRAKE SUPPLY EQUIPEMENT	
1	72357744	1	FAN	
			<>	
	72313268	4	NUT	DIN 934 M8-8A3L
	72393710	1	FLANGE	
	72315646	4	HEXAGONAL HEAD BOLT	DIN 933 M8X18-8.8A3L
	72315053	4	SPLIT WASHER	FWN 65208-8-A3L
2	72315668	4	HEXAGONAL HEAD BOLT	DIN 933 M8X50-8.8A3L
3	72315053	4	SPLIT WASHER	FWN 65208-8-A3L
4	72399875	1	INTERMEDIATE RING	
5	72395921	1	V BELT SHEAVE	
6	72379418	1	V-BELT SET (2 PIECE)	FWN66966-2XAVX10X1350LA
7	72394219	1	V BELT SHEAVE	
8	72315688	6	HEXAGONAL HEAD BOLT	M10 X 35 CL10.9
9	72315054	6	SPLIT WASHER	FWN 65208-10-A3L

FARMER 311 (198/05001-07700)
6652

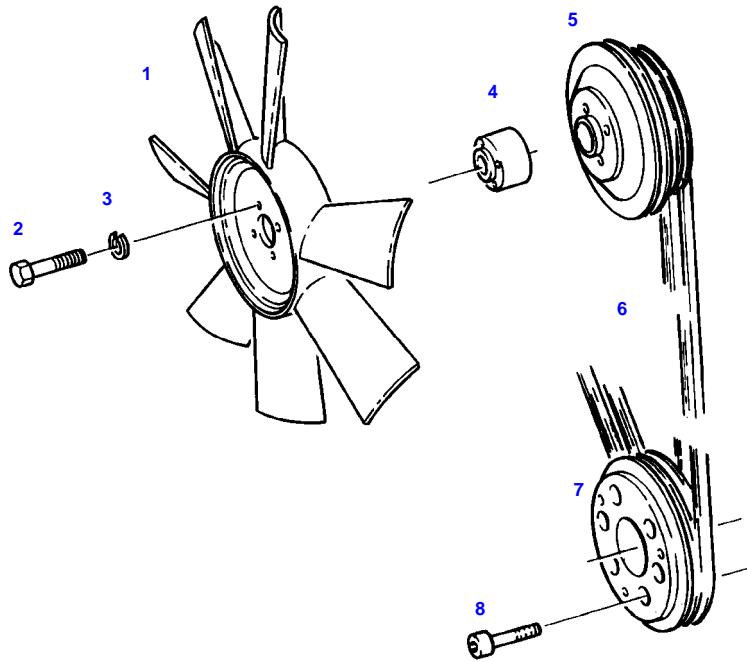

6652

Item	Part Number	Qty	Description Comments	Technical Specification
			RANGE OF TEMPERATURE 1+2 WITH AIR BRAKE EQU./AIR CONDITION	
1	72357744	1	FAN	
			<>	
	72393710	1	FLANGE	
	72315053	4	SPLIT WASHER	FWN 65208-8-A3L
	72315646	4	HEXAGONAL HEAD BOLT	DIN 933 M8X18-8.8A3L
	72313268	4	NUT	DIN 934 M8-8A3L
2	72315668	4	HEXAGONAL HEAD BOLT	DIN 933 M8X50-8.8A3L
3	72315053	4	SPLIT WASHER	FWN 65208-8-A3L
4	72399875	1	INTERMEDIATE RING	
5	72396359	1	V BELT SHEAVE	
6	72379418	1	V-BELT SET (2 PIECE)	FWN66966-2XAVX10X1350LA
7	72396002	1	V BELT SHEAVE	
8	72315498	6	SOCKET HEAD BOLT	DIN 912 M10X40-8.8 OB1-SW

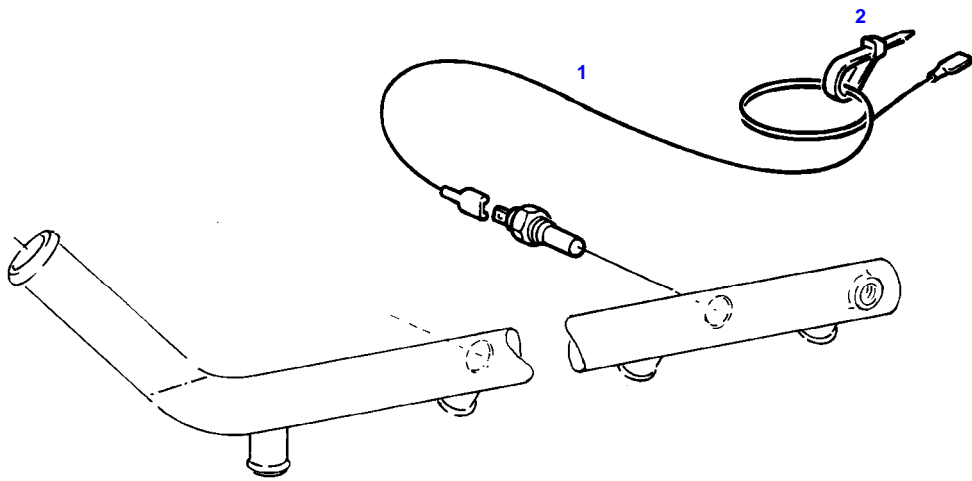

4584



Suggest:

For more complete manuals. Please go to the home page.

<https://www.ebooklibonline.com>

If the above button click is invalid. Please download this document first, and then click the above link to download the complete manual.

Thank you so much for reading

Fendt

FARMER 311 (198/05001-07700)

F198001

RESISTOR CABLE

Page01-0034

Item	Part Number	Qty	Description Comments	Technical Specification
			RANGE OF TEMPERATURE 2 WITH AIR BRAKE EQU./AIR CONDITION	
1	72357742	1	RESISTOR CABLE	
2	72316916	1	CABLE STRAP	FWN 66650 B175X4-SW

FARMER 311 (198/05001-07700)
4691

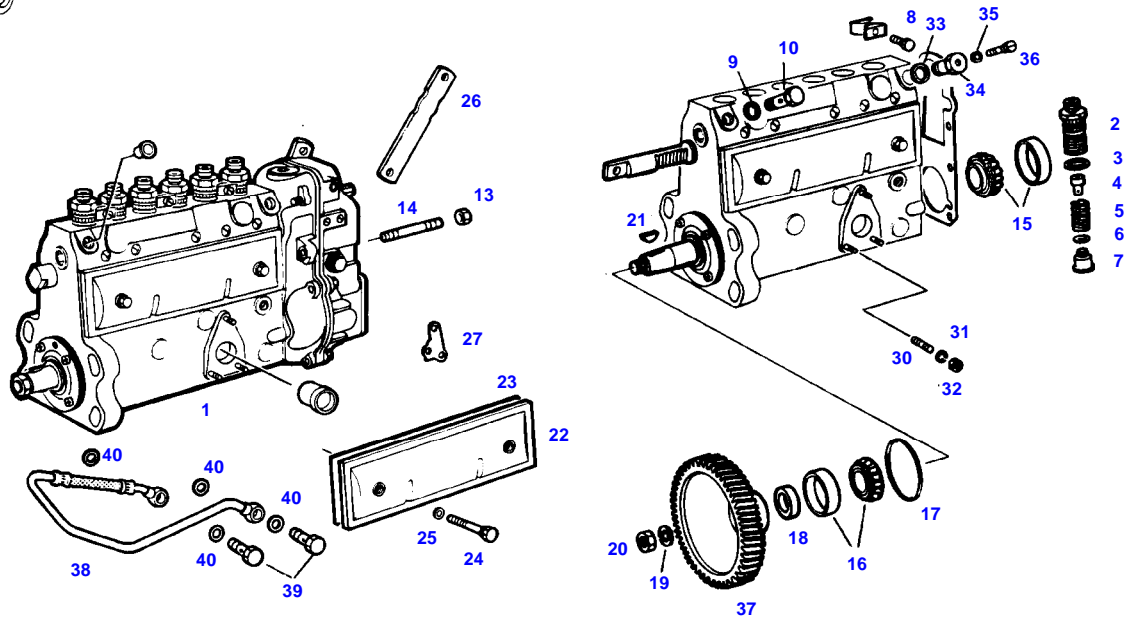

4691

<https://www.ebooklibonline.com>

Hello dear friend!

Thank you very much for reading.

Enter the link into your browser.

The full manual is available for immediate download.

<https://www.ebooklibonline.com>