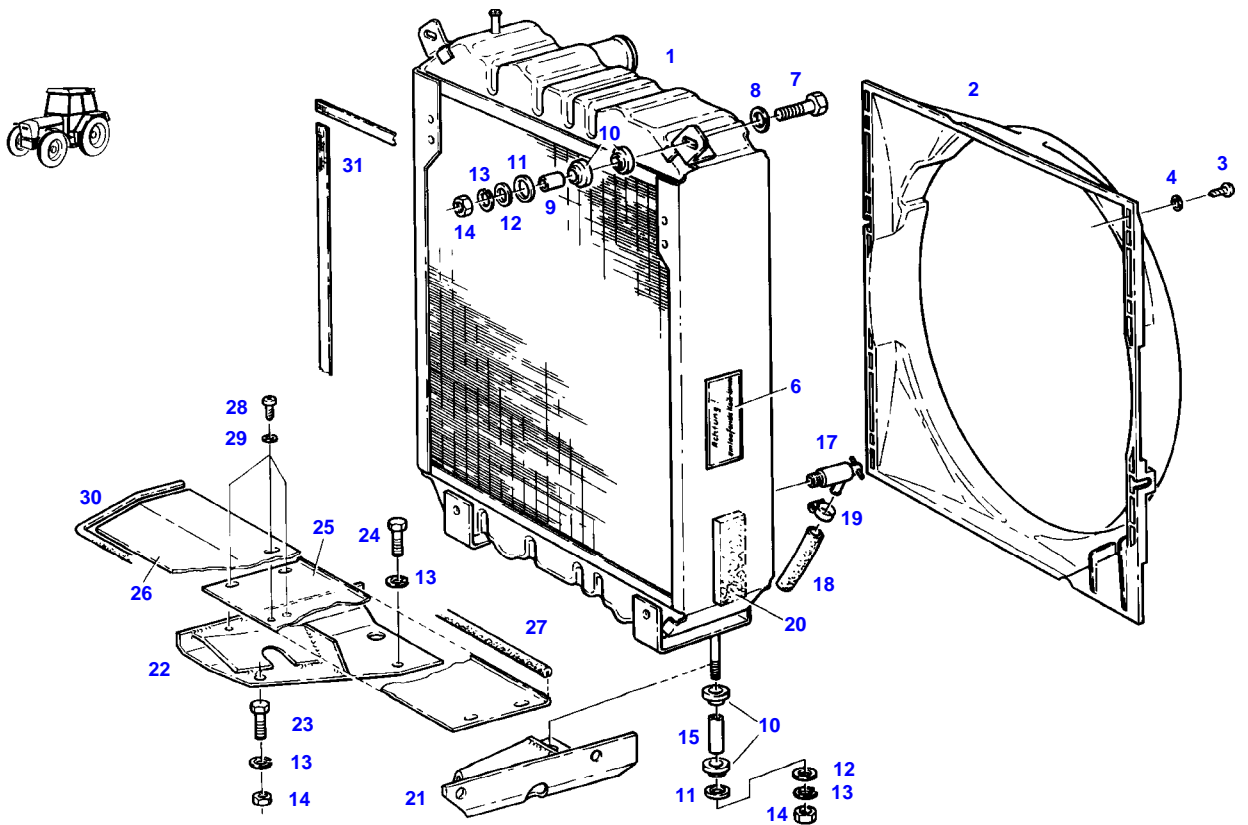

TABLE OF CONTENT

Page Number	Page Title	Page Reference
01-000-TOC	ENGINE, FUEL AND EXHAUST SYSTEM	01-000-TOC
02-000-TOC	AXLES	02-000-TOC
03-000-TOC	STEERING SYSTEM	03-000-TOC
04-000-TOC	DRIVE TRAIN SYSTEM	04-000-TOC
05-000-TOC	COMPRESSED AIR SYSTEM	05-000-TOC
06-000-TOC	HYDRAULIC SYSTEM	06-000-TOC
07-000-TOC	ELECTRICAL SYSTEM	07-000-TOC
08-000-TOC	CAB	08-000-TOC
09-000-TOC	AIR CONDITIONING AND HEATING SYSTEM	09-000-TOC
10-000-TOC	CHASSIS	10-000-TOC
11-000-TOC	WHEELS	11-000-TOC
12-000-TOC	IMPLEMENT LIFT SYSTEM FRONT	12-000-TOC
13-000-TOC	IMPLEMENT LIFT SYSTEM REAR	13-000-TOC
14-000-TOC	FRONT/REAR LOADERS	14-000-TOC
15-000-TOC	ACCESSORIES	15-000-TOC

FARMER 310 (192/03401-99999)
4581



4581

Item	Part Number	Qty	Description Comments	Technical Specification
			--> 192/20000	
1	72348671	1	RADIATOR RANGE OF TEMPERATURE 1+2 / 1+2 WITH RANGE OF TEMPERATURE 2+2 WITH AIR AIR BRAKE SUPPLY EQUIPEMENT	
	72348773	1	RADIATOR RANGE OF TEMPERATURE 2 WITH AIR CONDITION	
2	72396340	1	FAN COVER	
3	72315818	8	SCREW	DIN7976-ST4,2X25-C-A3L
4	72311817	8	DISC	DIN9021-4,3-140HV-A3L
6	72386100	2	WARNING SIGN D	
	72388085	2	WARNING SIGN GB	
	72388086	2	WARNING SIGN F	
	72388087	2	WARNING SIGN I	
	72388088	2	WARNING SIGN E	
7	72315663	2	HEXAGONAL HEAD BOLT	DIN 933 M8X40-8.8A3L
8	72311788	2	DISC	DIN 125-8,4-ST.A3L
9	72310718	2	BUSH	
10	72312479	8	UNIVERSAL SPOUT	
11	72311793	4	DISC	DIN 125-17-ST.A3L
12	72311824	4	DISC	DIN9021-8,4-140HV-A3L
13	72315053	8	SPLIT WASHER	FWN 65208-8-A3L
14	72313268	6	NUT	DIN 934 M8-8A3L
15	72396348	2	BUSH	
17	72378063	1	RELIEF VALVE	DIN71401-CM14X1,5KEG
18	72389310	1	HOSE	
19	72438345	1	HOSE CLIP	
20	72450582	1	SEALING STRIP 2X 120 MM CUT TO LENGTH	L=10M
21	72357349	1	BRACKET	
22	72357350	1	BRACKET	
23	72315665	2	HEXAGONAL HEAD BOLT	DIN 933 M8X45-8.8A3L
24	72315657	2	HEXAGONAL HEAD BOLT	DIN 933 M8 X 30-8.8A3L
25	72396346	1	COVER PLATE	
26	72396302	1	SPLASH PANEL	
27	72450971	1	SHAPED CORD 1X 510 MM CUT TO LENGTH	L=1000 FWN 63040 C02
28	72315820	6	SCREW	DIN7976-ST6,3X13-C-A3L
29	72311822	9	DISC	DIN9021-6,4-140HV-A3L
30	72450971	1	SHAPED CORD 1X 735 MM CUT TO LENGTH	L=1000 FWN 63040 C02
31	72450581	1	SEALING STRIP 2X 480 MM 2X 510 MM 1X 515 MM CUT TO LENGTH	L=20M

<https://www.ebooklibonline.com>

Hello dear friend!

Thank you very much for reading.

Enter the link into your browser.

The full manual is available for immediate download.

<https://www.ebooklibonline.com>

FARMER 310 (192/03401-99999)
7485

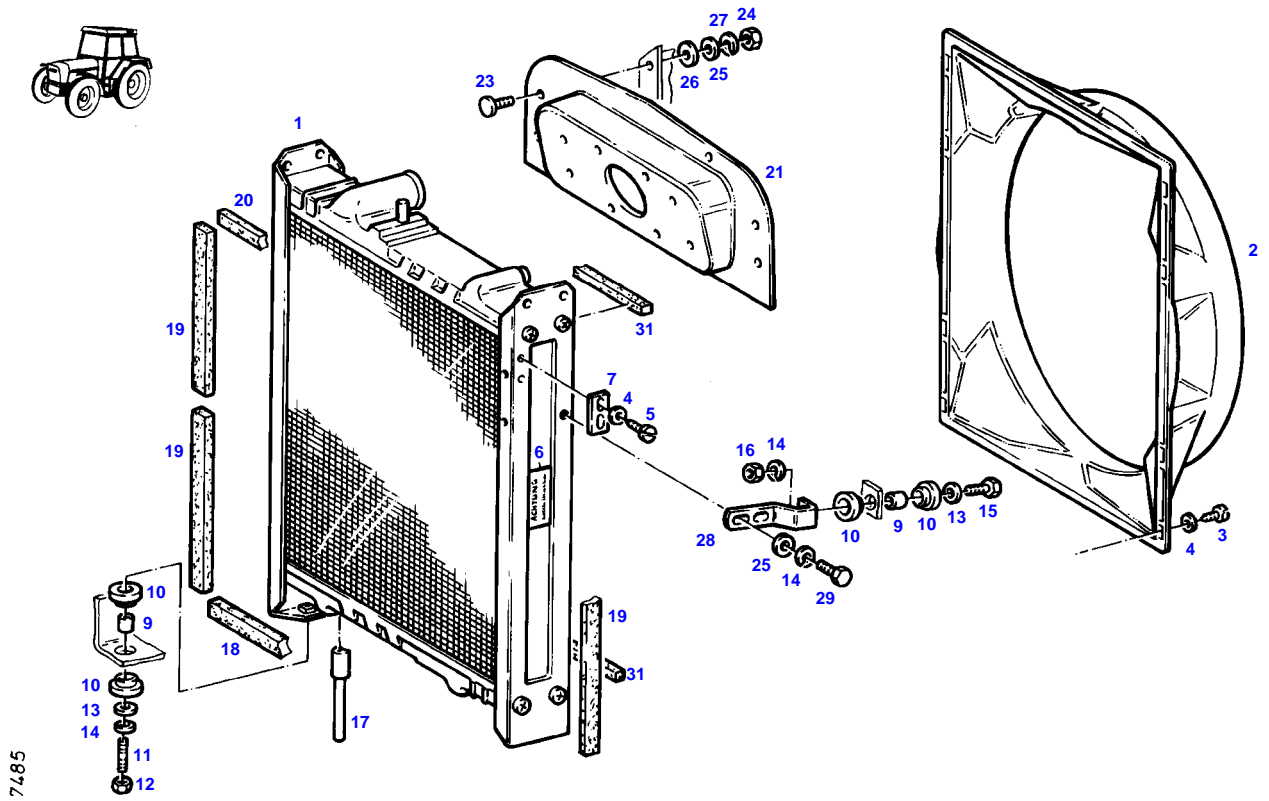

Item	Part Number	Qty	Description Comments	Technical Specification
			<-- 192/20001	
1	72348783	1	RADIATOR ><1	
	72436126	1	DRAIN PLUG	
2	72410558	1	FAN COVER	
3	72315818	8	SCREW	DIN7976-ST4,2X25-C-A3L
4	72311817	12	DISC	DIN9021-4,3-140HV-A3L
5	72374965	4	SCREW	DIN7976-ST4,2X9,5-C-A3L
6	72379109	1	MARKING PLATE	FWN66556-35X68-SCHUTZVORR.N.OE
7	72397311	1	ANGLE	
9	72310718	4	BUSH	
10	72312479	8	UNIVERSAL SPOUT	
11	72313772	2	STUD BOLT	DIN 939 M8X30-8.8
12	72313320	2	NUT	DIN6925-M8-8-A3L
13	72311824	4	DISC	DIN9021-8,4-140HV-A3L
14	72315053	4	SPLIT WASHER	FWN 65208-8-A3L
15	72315660	2	HEXAGONAL HEAD BOLT	DIN 933 M8X35-8.8A3L
16	72313268	2	NUT	DIN 934 M8-8A3L
17	72397310	1	DRAINAGE PIPING	
18	72310182	1	STRAP	
19	72397315	4	STRAP	
20	72397316	1	STRAP	
21	72397306	1	BARRIER WALL	
23	72373806	5	TRUSS HEAD SCREW	DIN 603 M6X16-A3L
24	72313266	5	NUT	DIN 934 M6-8A3L
25	72311787	7	DISC	DIN 125-6,4-ST.A3L
26	72311788	5	DISC	DIN 125-8,4-ST.A3L
27	72315052	5	SPLIT WASHER	FWN 65208-6-A3L
28	72397309	2	HOLDER	
29	72315642	4	HEXAGONAL HEAD BOLT	DIN 933 M8 X 16-8.8A3L
31	72450560	1	SEALING STRIP 2X 470MM CUT TO LENGTH	

FARMER 310 (192/03401-99999)
5787

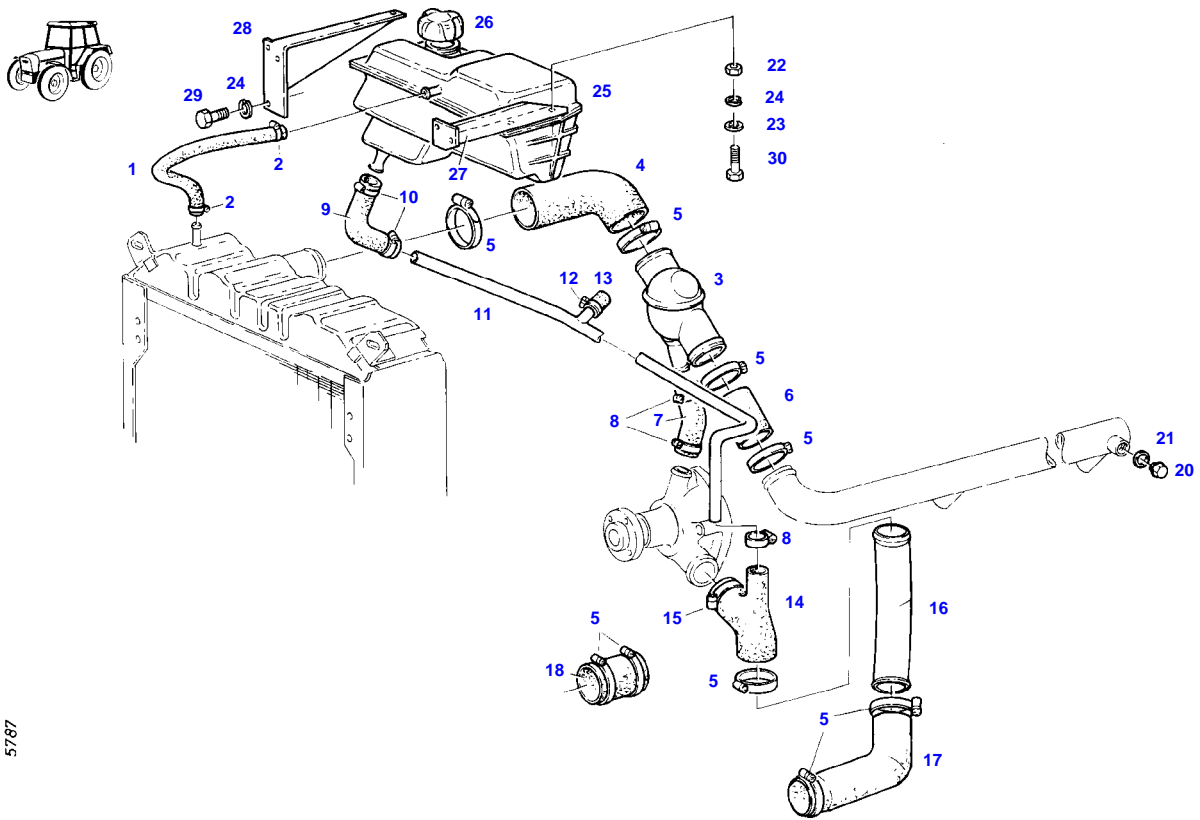

5787

Item	Part Number	Qty	Description Comments	Technical Specification
			--> 192/20000	
1	72622024	1	PRESSURE HOSE 300 MM CUT TO LENGTH	L=0,50M 8X3,5-FWN65911
2	72438345	2	HOSE CLIP	
3	72456610	1	THERMOSTAT	
	72343978	1	THERMOSTAT 85 C	
4	72396343	1	RUBBER ARCH	
5	72311163	7	HOSE CLIP	
6	72450417	1	HOSE 1X 60MM CUT TO LENGTH	L=100 DIN73411-45X5 R
7	72396344	1	RUBBER ARCH	
8	72311167	3	HOSE CLIP	
9	72396345	1	RUBBER ARCH	
10	72311166	2	HOSE CLIP	
11	72357352	1	PIPE	
12	72311166	1	HOSE CLIP	
13	72404925	1	CAP	
14	72396342	1	RUBBER ARCH	
15	72311162	1	HOSE CLIP	
16	72396356	1	SUCTION PIPE	
17	72396357	1	RUBBER ARCH	
18	72450417	1	HOSE 1X 60MM CUT TO LENGTH --> 192/2169	L=100 DIN73411-45X5 R
20	72315802	1	SCREW	DIN 7604 AM22X1,5-ST
21	72315101	2	SEALING WASHER	DIN 7603 A22X27-CU
22	72315821	4	SCREW	DIN7976-ST6,3X19-C-A3L
23	72311822	4	DISC	DIN9021-6,4-140HV-A3L
24	72315052	2	SPLIT WASHER	FWN 65208-6-A3L
25	72316897	1	EXPANSION TANK <>	
	72409370	1	CAP	
	72438345	1	HOSE CLIP	
26	72348672	1	COLLER LOCKING	
27	72395909	1	RETAINER	
28	72395908	1	RETAINER	
29	72315629	2	HEXAGONAL HEAD BOLT	DIN 933 M6 X 12-8.8A3L

FARMER 310 (192/03401-99999)
7486

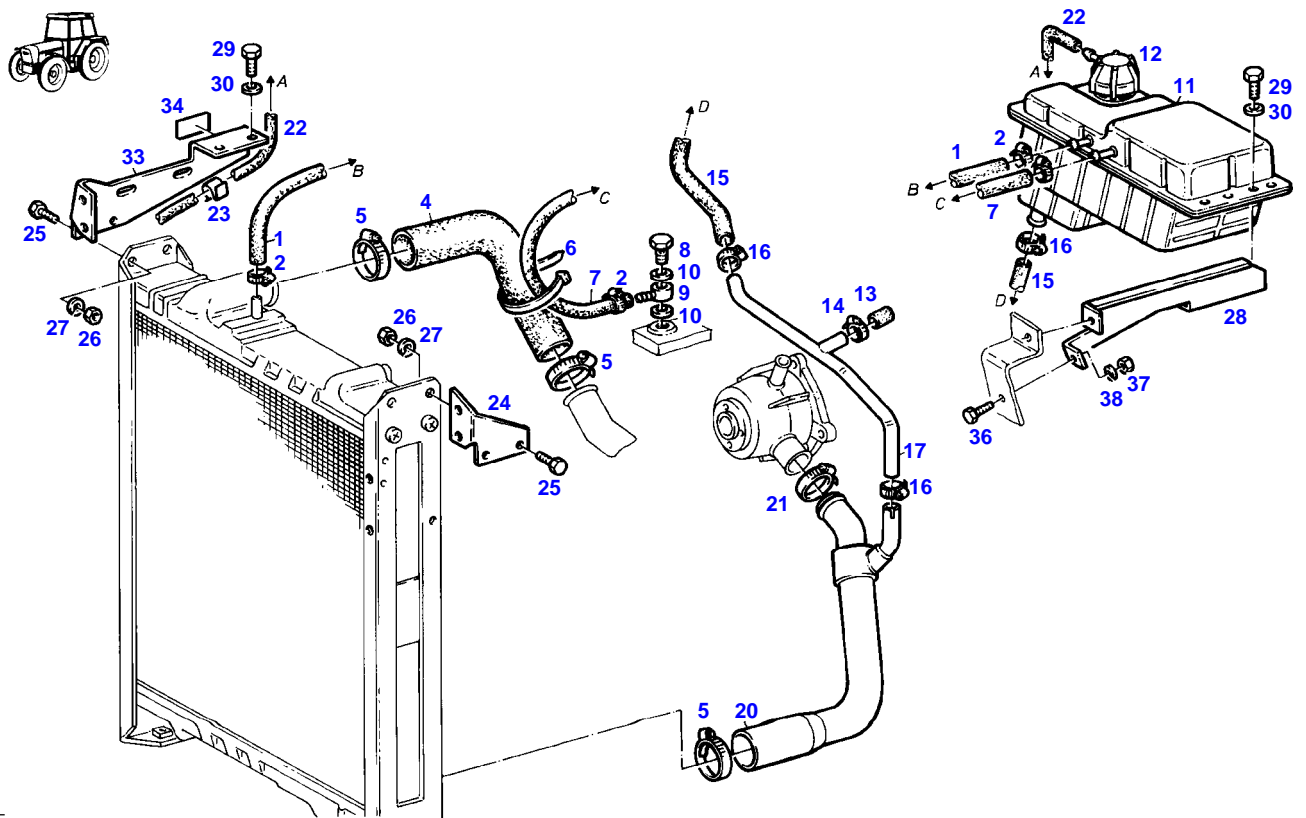

7486

Item	Part Number	Qty	Description Comments	Technical Specification
			<-- 192/20001	
1	72622024	1	PRESSURE HOSE 220 MM CUT TO LENGTH	L=0,50M 8X3,5-FWN65911
2	72438345	4	HOSE CLIP	
4	72397313	1	RUBBER ARCH	
5	72311170	3	HOSE CLIP	
6	72316915	1	CABLE STRAP	FWN 66650 B290X4,8-SW
7	72450289	1	PRESSURE HOSE 540 MM CUT TO LENGTH	L=550 FWN 66041-M4
8	72315806	1	BANJO BOLT	DIN 7643-6-3-A3L
9	72377528	1	RING HOSE NIPPLE	FWN65910-A-DN4
10	72315088	2	SEALING WASHER	DIN 7603 A10X13,5-CU
11	72316897	1	EXPANSION TANK	
12	72310924	1	COLLER LOCKING	
13	72404925	1	CAP	
14	72311166	1	HOSE CLIP	
15	72435840	1	HOSE ARCH	
16	72311166	3	HOSE CLIP	
17	72357764	1	PIPE	
20	72397314	1	COOLANT LINE	
21	72311162	1	HOSE CLIP	
22	72442422	1	HOSE 1100 MM CUT TO LENGTH	L=1500MM
23	72312049	3	HOSE RETAINER	
24	72397308	1	RETAINER	
25	72315642	2	HEXAGONAL HEAD BOLT	DIN 933 M8 X 16-8.8A3L
26	72313268	6	NUT	DIN 934 M8-8A3L
27	72315053	6	SPLIT WASHER	FWN 65208-8-A3L
28	72397312	1	BRACKET	
29	72315821	4	SCREW	DIN7976-ST6,3X19-C-A3L
30	72311822	4	DISC	DIN9021-6,4-140HV-A3L
33	72423219	1	RETAINER	
34	72397318	1	MARKING PLATE	
36	72315629	1	HEXAGONAL HEAD BOLT	DIN 933 M6 X 12-8.8A3L
37	72313266	1	NUT	DIN 934 M6-8A3L
38	72315052	1	SPLIT WASHER	FWN 65208-6-A3L

FARMER 310 (192/03401-99999)
7132

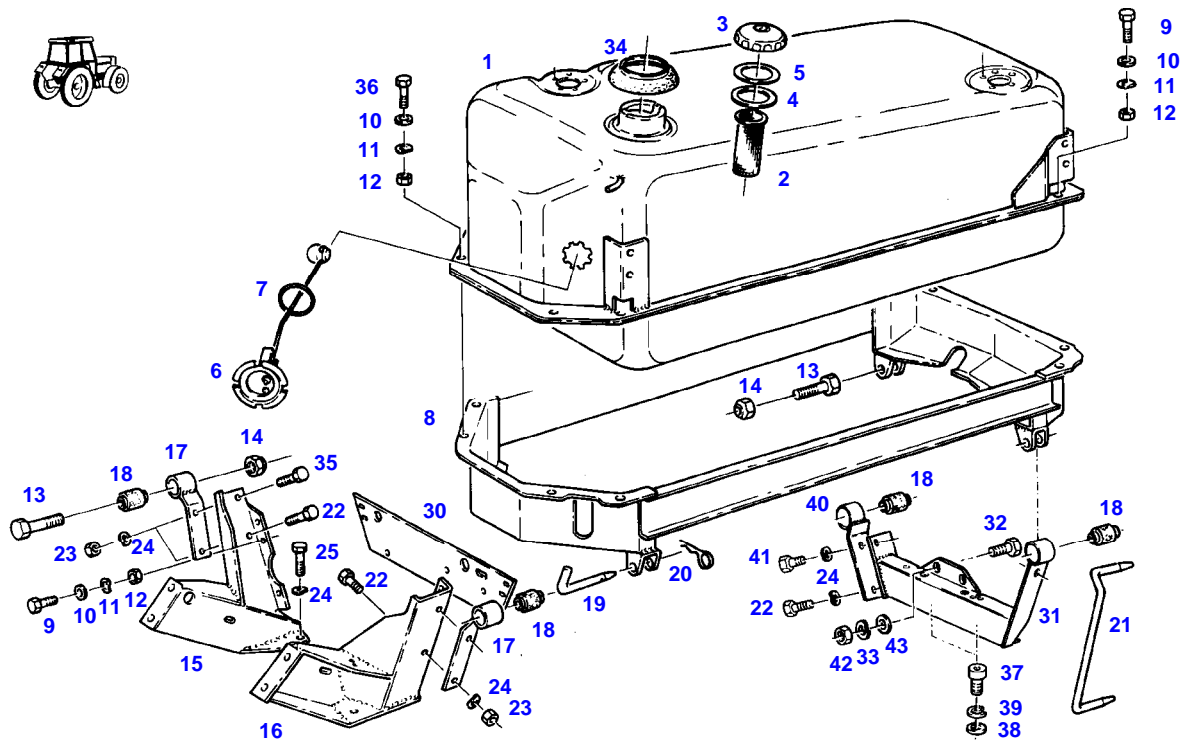

7132

Item	Part Number	Qty	Description Comments	Technical Specification
			--> 192/20000	
1	72349994	1	FUEL TANK	
2	72433112	1	STRAINER	60X100-MS
3	72380143	1	FUEL CAP KOEHLER	M.BELUEF
	72348297	1	><4 FUEL CAP LOCKABLE BLAU	
			><4+5	
4	72330725	1	SEAL BLAU	
	72312304	1	RUBBER SEAL KOEHLER	
5	72330726	1	SEAL	
6	72613427	1	FUEL LEVEL SENSOR ><7	
7	72315169	1	SEALING WASHER	
8	72357106	1	TANK FRAME	
9	72315626	9	HEXAGONAL HEAD BOLT	DIN 933-M6 X 16-8.8-A3L
10	72311822	20	DISC	DIN9021-6,4-140HV-A3L
11	72317120	15	SPRING WASHER	DIN 137 B6-MECH.VZK
12	72313266	15	NUT	DIN 934 M6-8A3L
13	72315719	2	HEXAGONAL HEAD BOLT	DIN 933 M12X60-8.8A3L
14	72313325	2	NUT	DIN 980-VM12-8-A3L
15	72355440	1	BRACKET	
16	72355441	1	BRACKET	
17	72357100	2	BEARING	
18	72310644	4	RUBBER BUSHING	
19	72404932	2	BEARING PIN	
20	72311183	2	HAIR COTTER PIN	DIN 11024-4-A3L
21	72393681	1	BEARING PIN	
22	72315657	5	HEXAGONAL HEAD BOLT	DIN 933 M8 X 30-8.8A3L
23	72313268	4	NUT	DIN 934 M8-8A3L
24	72317121	11	SPRING WASHER	DIN 137 B8-MECH.VZK
25	72315642	6	HEXAGONAL HEAD BOLT	DIN 933 M8 X 16-8.8A3L
30	72395911	1	SHEET METAL	
31	72357098	1	CROSSMEMBER	
	72357101	1	CROSSMEMBER AIR CONDITION	
32	72315689	2	HEXAGONAL HEAD BOLT	DIN 933 M10X35-8.8A3L
33	72317122	2	SPRING WASHER	DIN 137 B10-MECH.VZK
34	72397269	1	SLEEVE	
36	72315631	2	HEXAGONAL HEAD BOLT	DIN 933 M6 X 20-8.8A3L
37	72374066	2	SOCKET HEAD BOLT	DIN 912 M12X20-8.8
38	72311804	2	DISC	DIN 433-13-ST.A3L
39	72315055	2	SPLIT WASHER	FWN 65208-12-A3L
40	72357099	1	SUPPORT ARM	
41	72315653	1	HEXAGONAL HEAD BOLT	DIN 933 M8 X 25-8.8A3L
42	72313272	2	NUT	DIN 934 M10-8A3L
43	72311789	2	DISC	DIN 125-10,5-ST.A3L

FARMER 310 (192/03401-99999)
7697

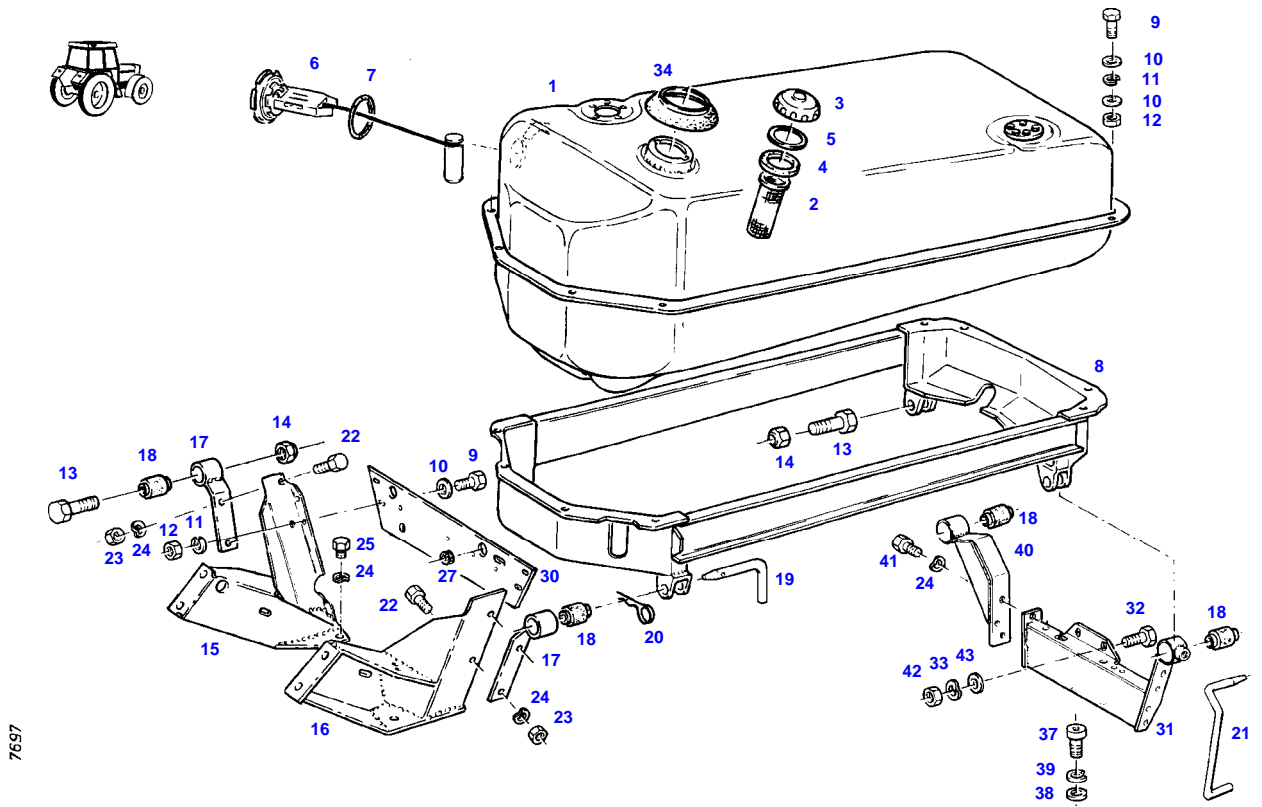

Item	Part Number	Qty	Description Comments	Technical Specification
			<-- 192/20001	
1	72357113	1	FUEL TANK	
2	72433112	1	STRAINER	60X100-MS
3	72380143	1	FUEL CAP KOEHLER	M.BELUEF
	72348297	1	><4 FUEL CAP LOCKABLE BLAU	
			><4+5	
4	72330725	1	SEAL BLAU	
	72312304	1	RUBBER SEAL KOEHLER	
5	72330726	1	SEAL	
6	72613427	1	FUEL LEVEL SENSOR ><7	
7	72315169	1	SEALING WASHER	
8	72357106	1	TANK FRAME	
9	72315626	11	HEXAGONAL HEAD BOLT	DIN 933-M6 X 16-8.8-A3L
10	72311822	20	DISC	DIN9021-6,4-140HV-A3L
11	72317120	13	SPRING WASHER	DIN 137 B6-MECH.VZK
12	72313266	13	NUT	DIN 934 M6-8A3L
13	72315719	2	HEXAGONAL HEAD BOLT	DIN 933 M12X60-8.8A3L
14	72313325	2	NUT	DIN 980-VM12-8-A3L
15	72355440	1	BRACKET	
16	72355441	1	BRACKET	
17	72357100	2	BEARING	
18	72310644	4	RUBBER BUSHING	
19	72407288	2	BEARING PIN	
20	72311183	2	HAIR COTTER PIN	DIN 11024-4-A3L
21	72393681	1	BEARING PIN	
22	72315657	5	HEXAGONAL HEAD BOLT	DIN 933 M8 X 30-8.8A3L
23	72313268	4	NUT	DIN 934 M8-8A3L
24	72317121	12	SPRING WASHER	DIN 137 B8-MECH.VZK
25	72315642	6	HEXAGONAL HEAD BOLT	DIN 933 M8 X 16-8.8A3L
27	72379152	1	CABLE BUSHING	HV1305
30	72397321	1	SHEET METAL	
31	72363528	1	CROSSMEMBER	
32	72315689	2	HEXAGONAL HEAD BOLT	DIN 933 M10X35-8.8A3L
33	72317122	2	SPRING WASHER	DIN 137 B10-MECH.VZK
34	72397269	1	SLEEVE	
37	72374066	2	SOCKET HEAD BOLT	DIN 912 M12X20-8.8
38	72311804	2	DISC	DIN 433-13-ST.A3L
39	72315055	2	SPLIT WASHER	FWN 65208-12-A3L
40	72357109	1	SUPPORT ARM	
41	72315653	1	HEXAGONAL HEAD BOLT	DIN 933 M8 X 25-8.8A3L
42	72313272	2	NUT	DIN 934 M10-8A3L
43	72311789	2	DISC	DIN 125-10,5-ST.A3L

FARMER 310 (192/03401-99999)
6662

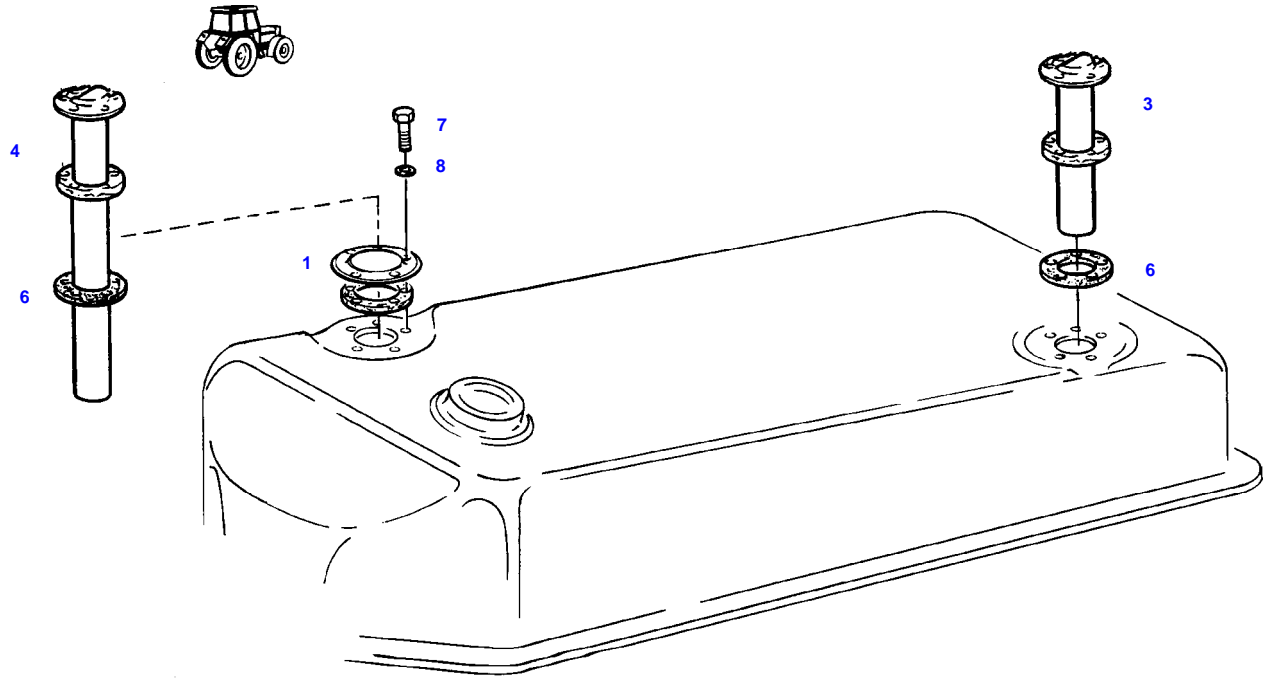

6662

Item	Part Number	Qty	Description Comments	Technical Specification
			--> 192/20000	
1	72409022	2	FLANGE	
3	72380155	1	FUEL LEVEL SENSOR BOARD COMPUTER	
4	72380154	1	FUEL LEVEL SENSOR BOARD COMPUTER	
6	72376132	2	SEALING WASHER	
7	72315619	10	HEXAGONAL HEAD BOLT	DIN 933 M5X16-8.8A3L
8	72376017	10	SEALING WASHER	DIN 7603-A5X7,5-CU

FARMER 310 (192/03401-99999)
40847

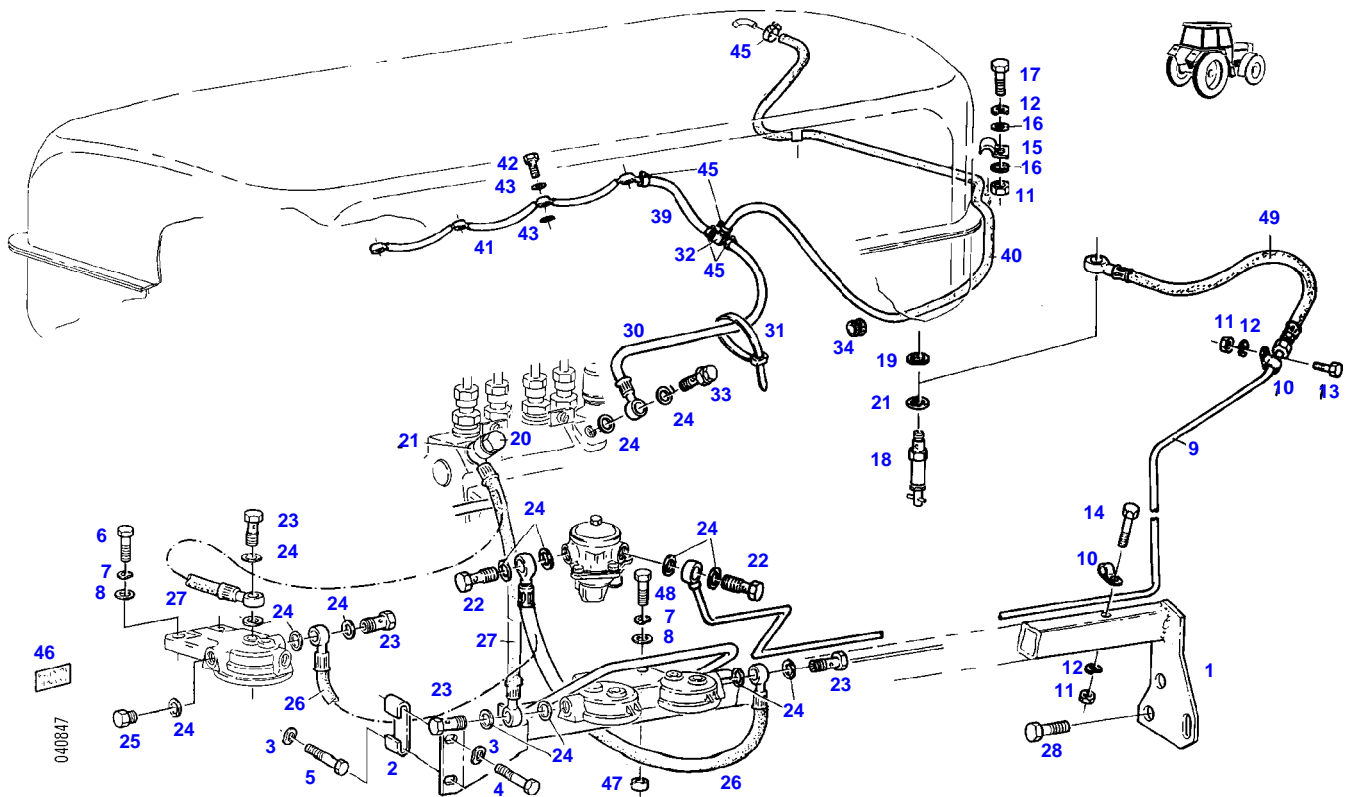

Item	Part Number	Qty	Description Comments	Technical Specification
			--> 192/20000	
1	72356743	1	RETAINER	
2	72399913	1	HOLDER	
3	72317122	2	SPRING WASHER	DIN 137 B10-MECH.VZK
4	72315689	1	HEXAGONAL HEAD BOLT	DIN 933 M10X35-8.8A3L
5	72315691	1	HEXAGONAL HEAD BOLT	DIN 933 M10X40-8.8A3L
6	72315657	2	HEXAGONAL HEAD BOLT	DIN 933 M8 X 30-8.8A3L
7	72317121	2	SPRING WASHER	DIN 137 B8-MECH.VZK
8	72311824	2	DISC	DIN9021-8,4-140HV-A3L
9	72356707	1	TUBING	
10	72311241	2	PIPE CLAMP	
11	72313266	2	NUT	DIN 934 M6-8A3L
12	72317120	2	SPRING WASHER	DIN 137 B6-MECH.VZK
13	72315626	1	HEXAGONAL HEAD BOLT	DIN 933-M6 X 16-8.8-A3L
14	72315637	1	HEXAGONAL HEAD BOLT	DIN 933 M6X45-8.8A3L
15	72398941	2	FASTENING COLLAR	
16	72311822	2	DISC	DIN9021-6,4-140HV-A3L
17	72315631	2	HEXAGONAL HEAD BOLT	DIN 933 M6 X 20-8.8A3L
18	72380159	1	FUEL SHUT-OFF VALVE	
19	72315093	1	SEALING WASHER	DIN 7603 A12X18-CU
20	72310187	1	DOUBLE BOLT	
21	72315095	2	SEALING WASHER	DIN 7603 A14X20-CU
22	72315808	2	BANJO BOLT	DIN 7643-10-3-A3L
23	72315808	2	BANJO BOLT	DIN 7643-10-3-A3L
24	72315095	14	SEALING WASHER	DIN 7603 A14X20-CU
25	72315799	2	PLUG	DIN 7604 AM14X1,5-A3L
26	72356760	1	FUEL LINE	
27	72355537	1	FUEL LINE	
28	72374490	2	HEXAGONAL HEAD BOLT	DIN 933 M14X20-8.8
	72374493	2	HEXAGONAL HEAD BOLT	DIN 933 M14X30-8.8
30	72356761	1	FUEL LINE	
			<>	
31	72316916	2	CABLE STRAP	FWN 66650 B175X4-SW
32	72380023	1	TEE FITTING	
33	72380268	1	BLEED AND DRAIN VALVE	
34	72379152	1	CABLE BUSHING	HV1305
39	72450301	1	PRESSURE HOSE	L=1000
			260 MM	
			CUT TO LENGTH	
40	72435830	1	PRESSURE HOSE	L=2100
			1100 MM	
			CUT TO LENGTH	
41			SEE FUEL LININGS	
42	72315809	4	BANJO BOLT	DIN 7643-4-5-A3L
	72342985	4	SCREW	
			ENGINE B	
43	72315086	8	SEALING WASHER	DIN 7603 A8X11,5-CU
	72315084	8	SEALING WASHER	DIN 7603 A6X10-CU
			ENGINE B	
45	72438345	5	HOSE CLIP	
46	72393682	1	MARKING PLATE	
			ARABIAN-ENGLISH	
47	72311848	2	DISC	
48	72315660	2	HEXAGONAL HEAD BOLT	DIN 933 M8X35-8.8A3L
49	72357312	1	HOSE LINE	

FARMER 310 (192/03401-99999)
7689

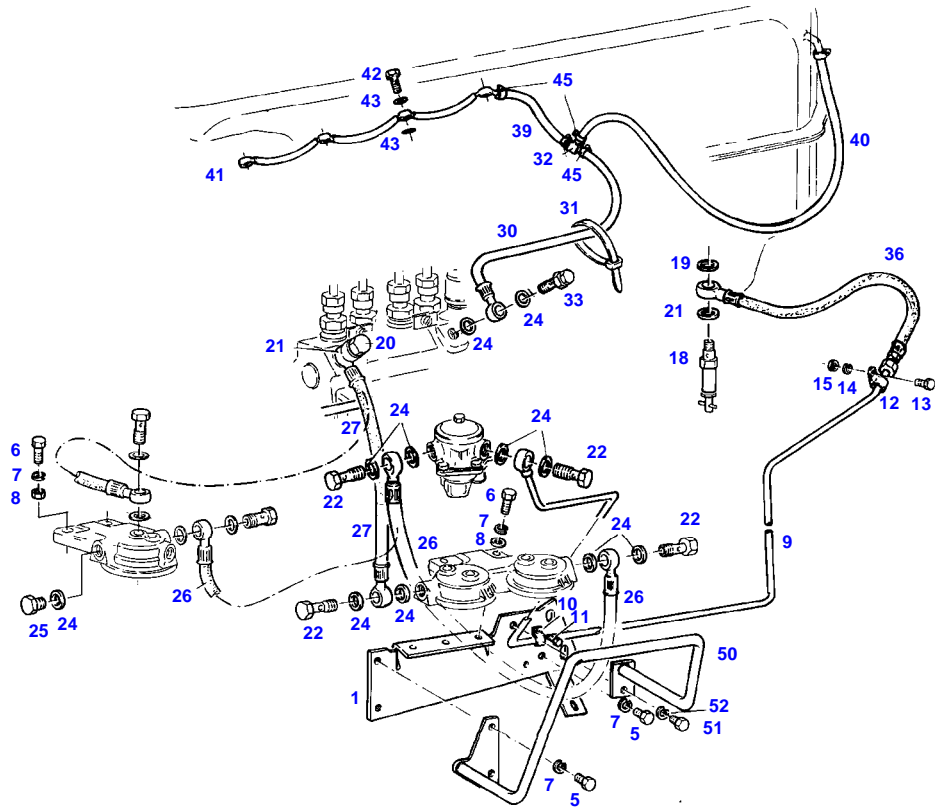

7689

Item	Part Number	Qty	Description Comments	Technical Specification
			<-- 192/20001	
1	72357112	1	FILTER RETAINER	
			<>	
	72310699	1	BUSH	
	72374969	1	SCREW	DIN7976-ST4,8X19-C-A3L
5	72315642	3	HEXAGONAL HEAD BOLT	DIN 933 M8 X 16-8.8A3L
6	72315657	2	HEXAGONAL HEAD BOLT	DIN 933 M8 X 30-8.8A3L
7	72315053	5	SPLIT WASHER	FWN 65208-8-A3L
8	72311824	2	DISC	DIN9021-8,4-140HV-A3L
9	72356707	1	TUBING	
10	72311241	2	PIPE CLAMP	
11	72315819	1	SCREW	DIN7976-ST4,8X13-C-A3L
	72311785	1	DISC	DIN 125-5,3-ST.A3L
12	72311241	1	PIPE CLAMP	
13	72315626	1	HEXAGONAL HEAD BOLT	DIN 933-M6 X 16-8.8-A3L
14	72315052	1	SPLIT WASHER	FWN 65208-6-A3L
15	72313266	1	NUT	DIN 934 M6-8A3L
18	72380159	1	FUEL SHUT-OFF VALVE	
19	72315093	1	SEALING WASHER	DIN 7603 A12X18-CU
20	72310187	1	DOUBLE BOLT	
21	72315095	2	SEALING WASHER	DIN 7603 A14X20-CU
22	72315808	4	BANJO BOLT	DIN 7643-10-3-A3L
24	72315095	14	SEALING WASHER	DIN 7603 A14X20-CU
25	72315799	2	PLUG	DIN 7604 AM14X1,5-A3L
26	72356760	1	FUEL LINE	
27	72356760	1	FUEL LINE	
30	72356761	1	FUEL LINE	
31	72316916	1	CABLE STRAP	FWN 66650 B175X4-SW
32	72380023	1	TEE FITTING	
33	72380268	1	BLEED AND DRAIN VALVE	
36	72356762	1	FUEL LINE	
39	72450301	1	PRESSURE HOSE 260 MM CUT TO LENGTH	L=1000
40	72450301	1	PRESSURE HOSE 750 MM CUT TO LENGTH	L=1000
41			SEE FUEL LININGS	
42	72315809	4	BANJO BOLT	DIN 7643-4-5-A3L
43	72315086	8	SEALING WASHER	DIN 7603 A8X11,5-CU
45	72438345	4	HOSE CLIP	
	72438345	1	HOSE CLIP	
50	72357121	1	PROTECTION BAR	
51	72315642	1	HEXAGONAL HEAD BOLT	DIN 933 M8 X 16-8.8A3L
52	72315053	1	SPLIT WASHER	FWN 65208-8-A3L

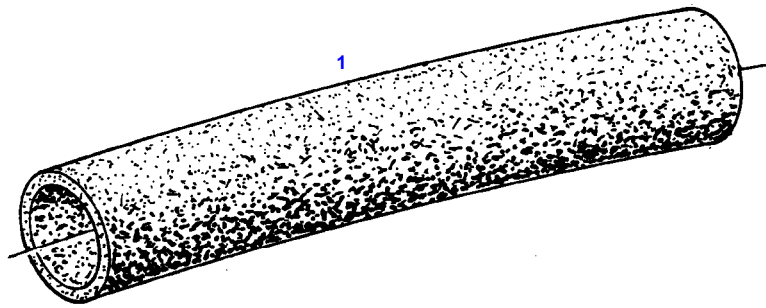

8555

Item	Part Number	Qty	Description Comments	Technical Specification
			RAPE SEED OIL METHYLATED ESTER	
1	72436293	1	HEAT SHRINK TUBING 1X 2500 MM CUT TO LENGTH	L=2600
	72436294	X	HEAT SHRINK TUBING 1X 3000 MM CUT TO LENGTH	L=3100
	72436295	1	HEAT SHRINK TUBING 1X 2000 MM CUT TO LENGTH	L=2100

FARMER 310 (192/03401-99999)
4952

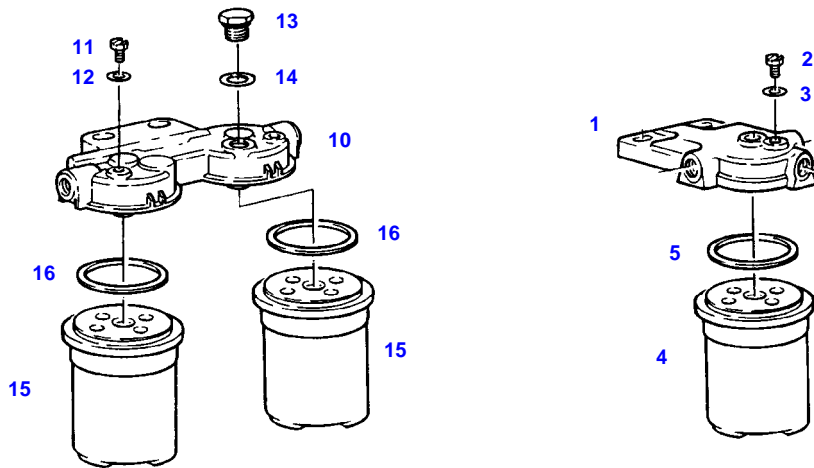

4952

Item	Part Number	Qty	Description Comments	Technical Specification
1	72615599	1	FILTER LID ><2,3	
2	72323290	1	BLEED SCREW	
3	72315084	1	SEALING WASHER	DIN 7603 A6X10-CU
4	72416928	1	FILTER BOX ><5	
5	72314995	1	RUBBER RING PARALLEL-FILTER	
10	72380173	1	PARALLEL FILTER BOSCH ><11-16 <-- X810.190.166.000 1X <>	
	72416928	2	FILTER BOX	
	72451307	1	COVER KNECHT ><11,12 <>	PARALLELFILT.
	72416928	2	FILTER BOX	
11	72323290	2	BLEED SCREW BOSCH	
	72314699	2	BLEED SCREW KNECHT	
12	72315084	2	SEALING WASHER BOSCH	DIN 7603 A6X10-CU
	72315086	2	SEALING WASHER KNECHT	DIN 7603 A8X11,5-CU
13	72326250	1	SCREW BOSCH	
14	72315095	1	SEALING WASHER BOSCH	DIN 7603 A14X20-CU
15	72416928	2	FILTER BOX ><16	
16	72314995	2	RUBBER RING	

FARMER 310 (192/03401-99999)
5273

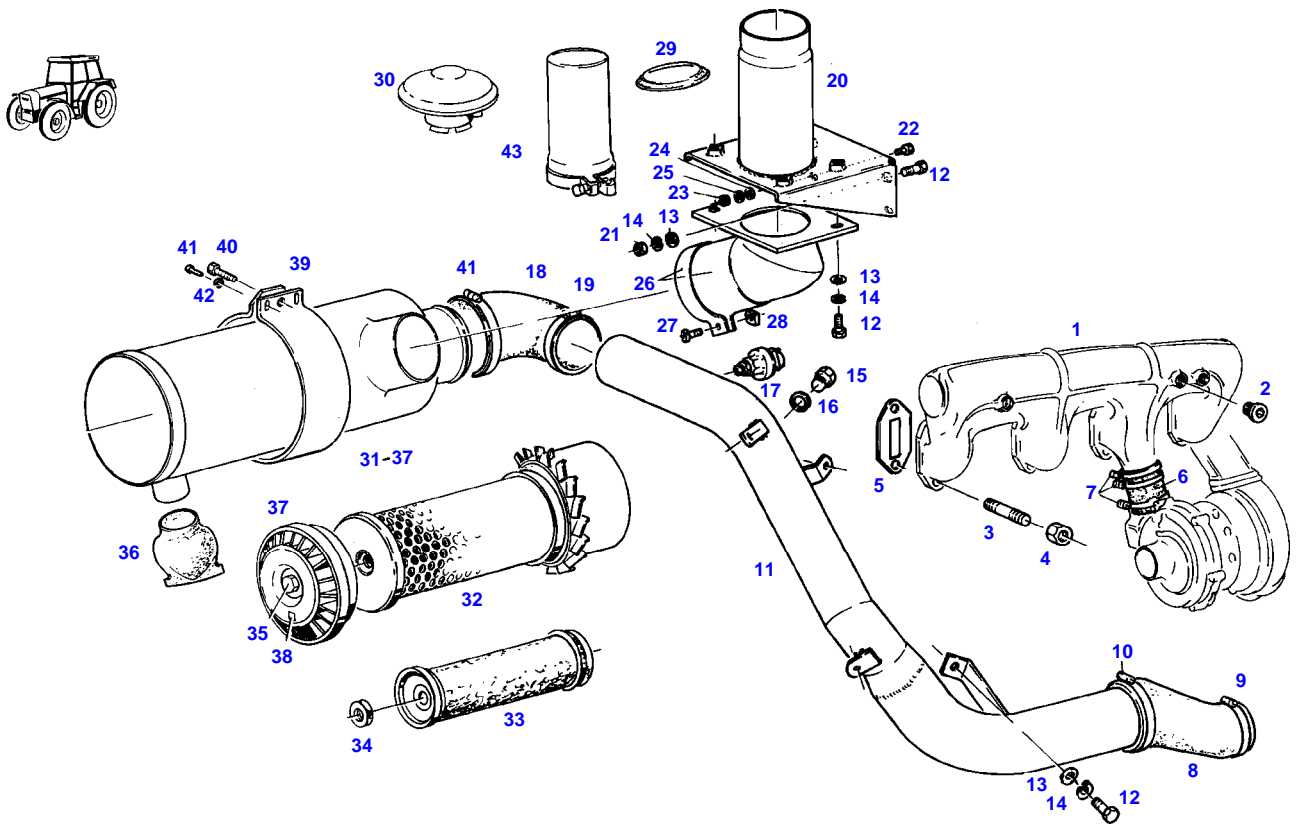

5273

Item	Part Number	Qty	Description Comments	Technical Specification
			PICLON --> 192/20000	
1	72395925	1	INTAKE MANIFOLD	
2	72315433	1	SCREW	DIN 906 M14X1,5-ST
3	72373922	8	STUD BOLT	DIN 835-M10X25-8.8
4	72373015	8	NUT	DIN70615-M10-8-A3B
5	72332145	4	MOLDED SEAL	
6	72332526	1	HOSE PIECE	
7	72311163	3	HOSE CLIP	
8	72395924	1	REDUCER	
9	72311163	1	HOSE CLIP	
10	72311171	2	HOSE CLIP	
11	72357103	1	INTAKE MANIFOLD	
12	72315650	4	HEXAGONAL HEAD BOLT	DIN 933 M8 X 20-8.8A3L
13	72311788	6	DISC	DIN 125-8,4-ST.A3L
14	72315053	4	SPLIT WASHER	FWN 65208-8-A3L
15	72315802	1	SCREW	DIN 7604 AM22X1,5-ST
16	72315101	1	SEALING WASHER	DIN 7603 A22X27-CU
17	72379892	1	MAINTENANCE SWITCH	
18	72395912	1	RUBBER ARCH	
19	72311170	1	HOSE CLIP	
20	72357730	1	CONSOLE	
21	72313268	2	NUT	DIN 934 M8-8A3L
22	72315626	1	HEXAGONAL HEAD BOLT	DIN 933-M6 X 16-8.8-A3L
23	72313266	1	NUT	DIN 934 M6-8A3L
24	72311787	2	DISC	DIN 125-6,4-ST.A3L
25	72315052	1	SPLIT WASHER	FWN 65208-6-A3L
26	72357729	1	PIPE BEND	
27	72374982	1	OVAL HEAD SCREW	DIN 7985 M6X25-4.8A3L
28	72372783	1	SQUARE NUT	DIN 557 M6-5 A3L
29	72396307	1	SEALING RING	
30	72331302	1	RAIN CAP	
31	72348775	1	AIR FILTER MANN + HUMMEL ><32-37	
	72348775	1	AIR FILTER KNECHT ><32-37	
32	72332577	1	MICRO-TOP CARTRIDGE	
33	72332126	1	SAFETY CARTRIDGE	
34	72372827	1	NUT	DIN 934 M16X1,5-10A3L
	72372763	1	MANN + HUMMEL NUT KNECHT	DIN 439 BM16-04A3L
35	72339030	1	COLLAR NUT MANN + HUMMEL	
	72332977	1	FASTENING NUT KNECHT	
36	72332513	1	DUST DISCHARGE VALVE MANN + HUMMEL	
	72332975	1	VALVE KNECHT	
37	72332518	1	COVER MANN + HUMMEL	
	72332976	1	COVER KNECHT <-- G199.200.090.010	
38	72395907	1	ABSORPTION INDICATOR	
39	72396306	1	CLAMP	
40	72315634	1	HEXAGONAL HEAD BOLT	DIN 933 M6X30-8.8A3L
41	72315814	2	SCREW	DIN7976-ST4,8X16-F-A3L
42	72311785	2	DISC	DIN 125-5,3-ST.A3L
43	72348666	1	CONNECTING PIPE	

FARMER 310 (192/03401-99999)
7491

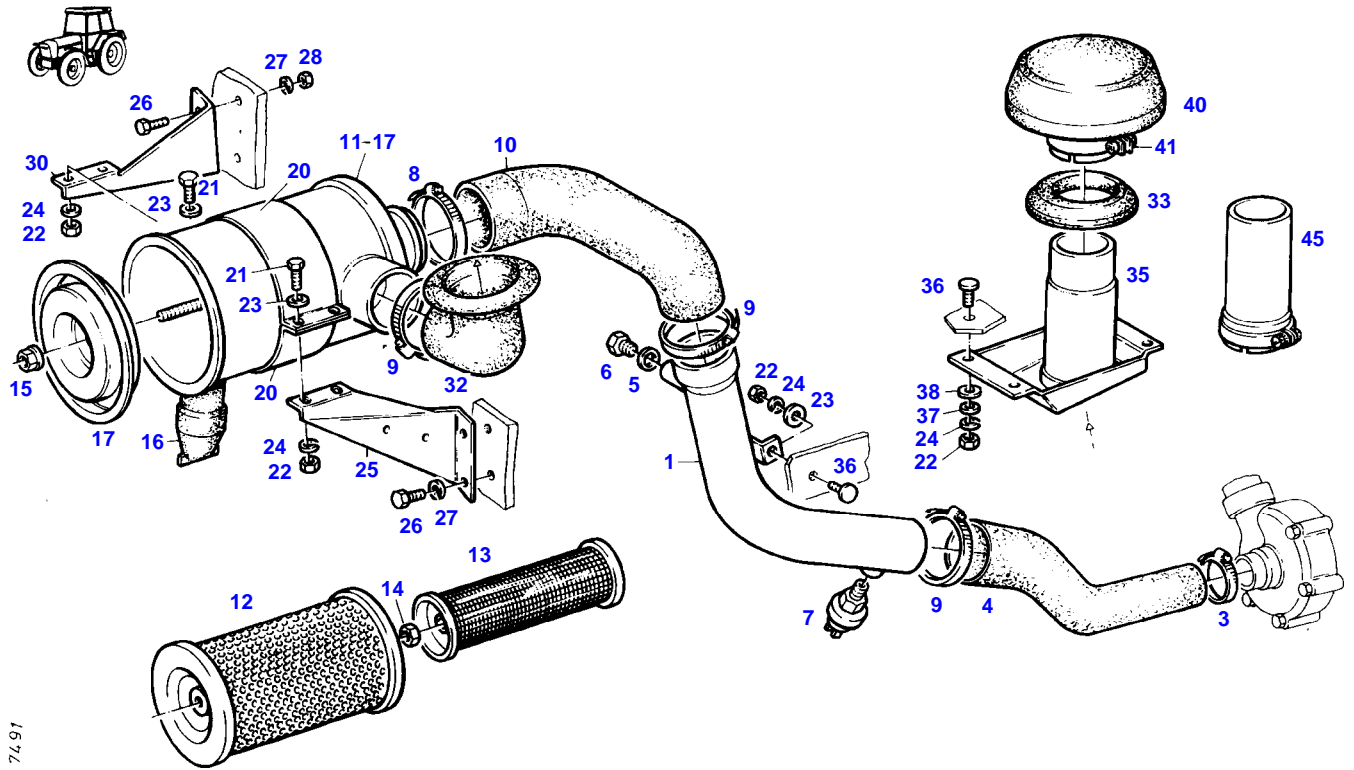

7491

Item	Part Number	Qty	Description Comments	Technical Specification
			PICLON <-- 192/20001	
1	72357114	1	INTAKE MANIFOLD	
3	72311170	1	HOSE CLIP	
4	72395931	1	REDUCER	
5	72315101	1	SEALING WASHER	DIN 7603 A22X27-CU
6	72315802	1	SCREW	DIN 7604 AM22X1,5-ST
7	72316876	1	MAINTENANCE SWITCH	
8	72311172	1	HOSE CLIP	
9	72311171	3	HOSE CLIP	
10	72395930	1	RUBBER ARCH	
11	72348775	1	AIR FILTER MANN + HUMMEL ><12-17	
	72348775	1	AIR FILTER KNECHT ><12-17	
12	72332577	1	MICRO-TOP CARTRIDGE	
13	72332126	1	SAFETY CARTRIDGE	
14	72313299	1	NUT	DIN 936-M16X1,5-17H
	72372763	1	NUT MANN + HUMMEL KNECHT	DIN 439 BM16-04A3L
15	72339030	1	COLLAR NUT MANN + HUMMEL	
	72332977	1	FASTENING NUT KNECHT	
16	72332513	1	DUST DISCHARGE VALVE MANN + HUMMEL	
	72332975	1	VALVE KNECHT	
17	72332518	1	COVER MANN + HUMMEL	
	72332976	1	COVER KNECHT <-- G199.200.090.010	
20	72397325	2	CLAMP	
21	72315626	4	HEXAGONAL HEAD BOLT	DIN 933-M6 X 16-8.8-A3L
22	72313266	9	NUT	DIN 934 M6-8A3L
23	72311822	7	DISC	DIN9021-6,4-140HV-A3L
24	72315052	8	SPLIT WASHER	FWN 65208-6-A3L
25	72407293	1	RETAINER	
26	72315642	4	HEXAGONAL HEAD BOLT	DIN 933 M8 X 16-8.8A3L
27	72315053	4	SPLIT WASHER	FWN 65208-8-A3L
28	72313268	2	NUT	DIN 934 M8-8A3L
30	72407295	1	RETAINER	
32	72397326	1	BELLOWS	
33	72397329	1	SEALING RING	
35	72357774	1	AIR INTAKE	
36	72373809	5	TRUSS HEAD SCREW	DIN 603 M6X20-A3L
37	72311787	4	DISC	DIN 125-6,4-ST.A3L
38	72311788	4	DISC	DIN 125-8,4-ST.A3L
40	72348784	1	RAIN CAP ><41	
41	72333025	1	PIPE CLAMP	
45	72348666	1	CONNECTING PIPE	

FARMER 310 (192/03401-99999)
7780

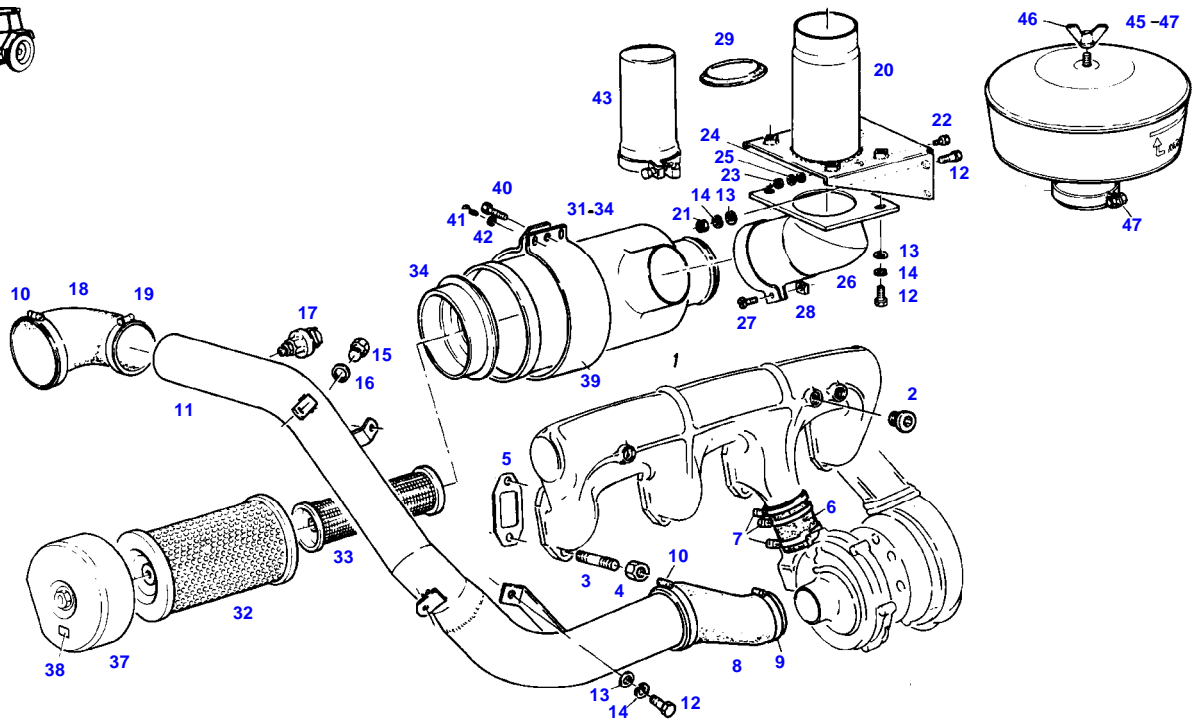

7780

Item	Part Number	Qty	Description Comments	Technical Specification
			PICO --> 192/20000	
1	72395925	1	INTAKE MANIFOLD	
2	72315433	1	SCREW	DIN 906 M14X1,5-ST
3	72373922	8	STUD BOLT	DIN 835-M10X25-8.8
4	72373015	8	NUT	DIN70615-M10-8-A3B
5	72332145	4	MOLDED SEAL	
6	72332526	1	HOSE PIECE	
7	72311163	3	HOSE CLIP	
8	72395924	1	REDUCER	
9	72311163	1	HOSE CLIP	
10	72311171	2	HOSE CLIP	
11	72357103	1	INTAKE MANIFOLD	
12	72315650	4	HEXAGONAL HEAD BOLT	DIN 933 M8 X 20-8.8A3L
13	72311788	6	DISC	DIN 125-8,4-ST.A3L
14	72315053	4	SPLIT WASHER	FWN 65208-8-A3L
15	72315802	1	SCREW	DIN 7604 AM22X1,5-ST
16	72315101	1	SEALING WASHER	DIN 7603 A22X27-CU
17	72379892	1	MAINTENANCE SWITCH	
18	72395912	1	RUBBER ARCH	
19	72311170	1	HOSE CLIP	
20	72357730	1	CONSOLE	
21	72313268	2	NUT	DIN 934 M8-8A3L
22	72315626	1	HEXAGONAL HEAD BOLT	DIN 933-M6 X 16-8.8-A3L
23	72313266	1	NUT	DIN 934 M6-8A3L
24	72311787	2	DISC	DIN 125-6,4-ST.A3L
25	72315052	1	SPLIT WASHER	FWN 65208-6-A3L
26	72357729	1	PIPE BEND	
27	72374982	1	OVAL HEAD SCREW	DIN 7985 M6X25-4.8A3L
28	72372783	1	SQUARE NUT	DIN 557 M6-5 A3L
29	72396307	1	SEALING RING	
31	72348780	1	AIR FILTER ><32-34	
32	72332577	1	MICRO-TOP CARTRIDGE	
33	72332126	1	SAFETY CARTRIDGE	
34	72332999	1	GUIDE RING	
37			NO SPARE PART	
38	72395907	1	ABSORPTION INDICATOR	
39	72396306	1	CLAMP	
40	72315634	1	HEXAGONAL HEAD BOLT	DIN 933 M6X30-8.8A3L
41	72315814	2	SCREW	DIN7976-ST4,8X16-F-A3L
42	72311785	2	DISC	DIN 125-5,3-ST.A3L
43	72348666	1	CONNECTING PIPE	
45	72348552	1	PRE-CLEANER ><45-47	
	72311582	1	DUST CUP	
46	72313238	1	WING NUT	
47	72332464	1	HOSE CLIP	

Item	Part Number	Qty	Description Comments	Technical Specification
			PICO <-- 192/20001	
1	72357114	1	INTAKE MANIFOLD	
3	72311170	1	HOSE CLIP	
4	72395931	1	REDUCER	
5	72315101	1	SEALING WASHER	DIN 7603 A22X27-CU
6	72315802	1	SCREW	DIN 7604 AM22X1,5-ST
7	72316876	1	MAINTENANCE SWITCH	
8	72311172	1	HOSE CLIP	
9	72311171	3	HOSE CLIP	
10	72395930	1	RUBBER ARCH	
11	72348780	1	AIR FILTER ><12-17	
12	72332577	1	MICRO-TOP CARTRIDGE	
13	72332126	1	SAFETY CARTRIDGE	
14	72332999	1	GUIDE RING	
15	72372763	1	NUT	DIN 439 BM16-04A3L
17			NO SPARE PART	
20	72397325	2	CLAMP	
21	72315626	4	HEXAGONAL HEAD BOLT	DIN 933-M6 X 16-8.8-A3L
22	72313266	9	NUT	DIN 934 M6-8A3L
23	72311822	7	DISC	DIN9021-6,4-140HV-A3L
24	72315052	8	SPLIT WASHER	FWN 65208-6-A3L
25	72407293	1	RETAINER	
26	72315642	4	HEXAGONAL HEAD BOLT	DIN 933 M8 X 16-8.8A3L
27	72315053	4	SPLIT WASHER	FWN 65208-8-A3L
28	72313268	2	NUT	DIN 934 M8-8A3L
30	72407295	1	RETAINER	
32	72397326	1	BELLOWS	
33	72397329	1	SEALING RING	
35	72357774	1	AIR INTAKE	
36	72373809	5	TRUSS HEAD SCREW	DIN 603 M6X20-A3L
37	72311787	4	DISC	DIN 125-6,4-ST.A3L
38	72311788	4	DISC	DIN 125-8,4-ST.A3L
40	72348552	1	PRE-CLEANER >>40-42	
	72311582	1	DUST CUP	
41	72313238	1	WING NUT	
42	72332464	1	HOSE CLIP	

FARMER 310 (192/03401-99999)
7781

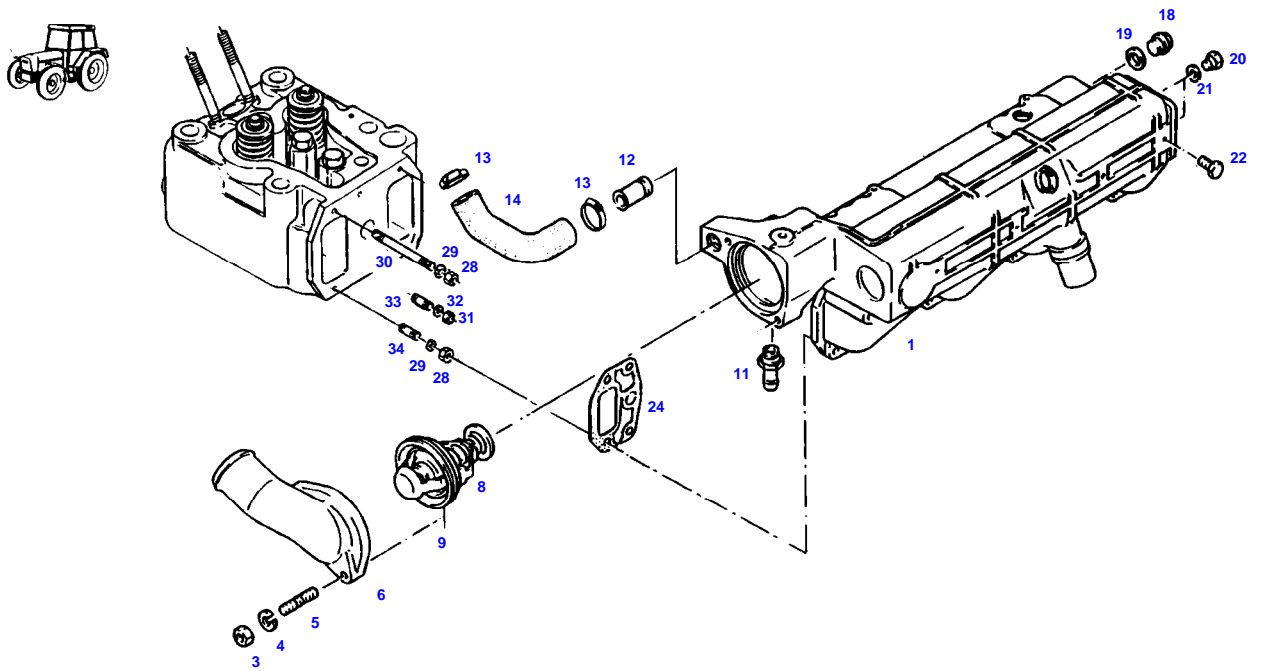

7781

Item	Part Number	Qty	Description Comments	Technical Specification
			<-- 192/20001	
1	72395928	1	INTAKE MANIFOLD	
3	72372805	2	NUT	DIN 934 M8-10 C2A
4	72315053	2	SPLIT WASHER	FWN 65208-8-A3L
5	72373904	2	STUD BOLT	DIN 835-M8X30-8.8
6	72397293	1	COVER	
8	72348782	1	THERMOSTAT	
	72333024	1	THERMOSTAT ><9 85 C SCANDINAVIA	
9	72397296	1	BRUSH SEALING	
11	72396595	1	HOSE BARB	
12	72411402	1	HOSE BARB	
	72315101	1	SEALING WASHER	DIN 7603 A22X27-CU
13	72311168	2	HOSE CLIP	
14	72397294	1	RUBBER ARCH 130MM	
	72395453	1	RUBBER ARCH 145MM	
18	72315802	1	SCREW	DIN 7604 AM22X1,5-ST
19	72315101	1	SEALING WASHER	DIN 7603 A22X27-CU
20	72315798	1	PLUG	DIN 7604 AM12X1,5-ST
21	72315093	1	SEALING WASHER	DIN 7603 A12X18-CU
22	72315614	1	HEXAGONAL HEAD BOLT	DIN 933-M4X8-8.8-A3L
24	72397295	4	MOLDED SEAL	
28	72373015	8	NUT	DIN70615-M10-8-A3B
29	72315054	8	SPLIT WASHER	FWN 65208-10-A3L
30	72374658	4	STUD BOLT	DIN 939-M10X100-8.8
31	72313269	4	NUT	DIN 934 M8-8C2A
32	72315053	4	SPLIT WASHER	FWN 65208-8-A3L
33	72397298	4	STUD BOLT	
34	72374646	4	STUD BOLT	DIN 939 M10X30-8.8

FARMER 310 (192/03401-99999)
5274

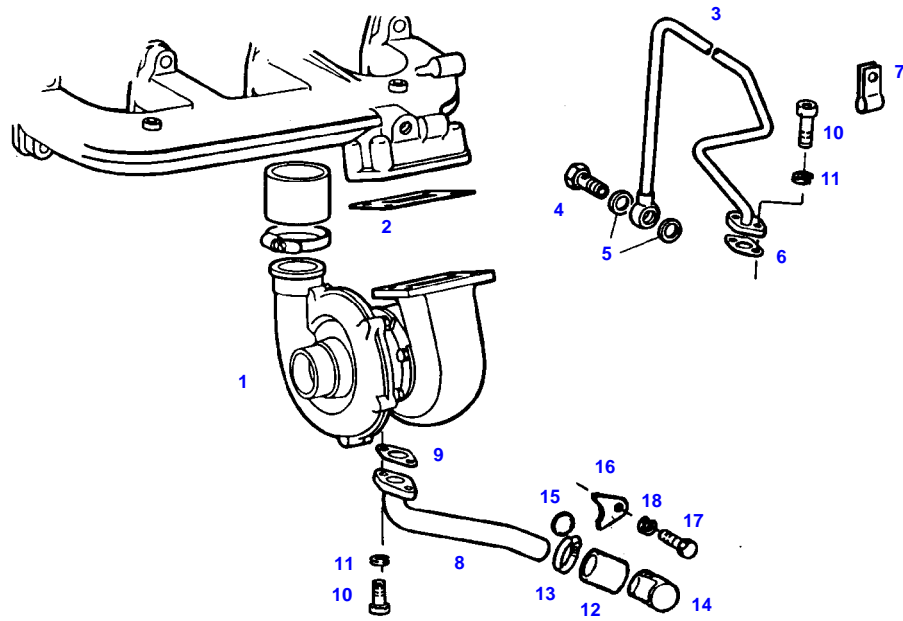

5274

Item	Part Number	Qty	Description Comments	Technical Specification
			--> 192/20000	
1	72332433	1	TURBOCHARGER	
	72332434	1	SPARE PARTS KIT	
2			SEE EXHAUST	
3	72332435	1	LUBE OIL LINE	
4	72374956	1	BANJO BOLT	DIN7623/3.70-A10-6.8
5	72315098	2	SEALING WASHER	DIN 7603 A16X22-CU
6	72332436	1	OVAL GASKET	
7	72332437	1	PIPE CLAMP	
8	72332438	1	LUBE OIL LINE	
9	72332161	1	OVAL GASKET	
10	72374020	2	SOCKET HEAD BOLT	DIN 912 M8X20-10.9
	72315474	2	SOCKET HEAD BOLT	
11	72315053	4	SPLIT WASHER	FWN 65208-8-A3L
12	72332160	1	HOSE PIECE	
13	72311167	2	HOSE CLIP	
14	72343888	1	MANIFOLD	
15	72343889	1	SEAL	
16	72343890	1	RETAINING SHEET METAL	
17	72315489	1	SOCKET HEAD BOLT	DIN 912-M8 X 16-8.8-A3L
18	72315053	1	SPLIT WASHER	FWN 65208-8-A3L



Suggest:

For more complete manuals. Please go to the home page.

<https://www.ebooklibonline.com>

If the above button click is invalid. Please download this document first, and then click the above link to download the complete manual.

Thank you so much for reading

FARMER 310 (192/03401-99999)
7692

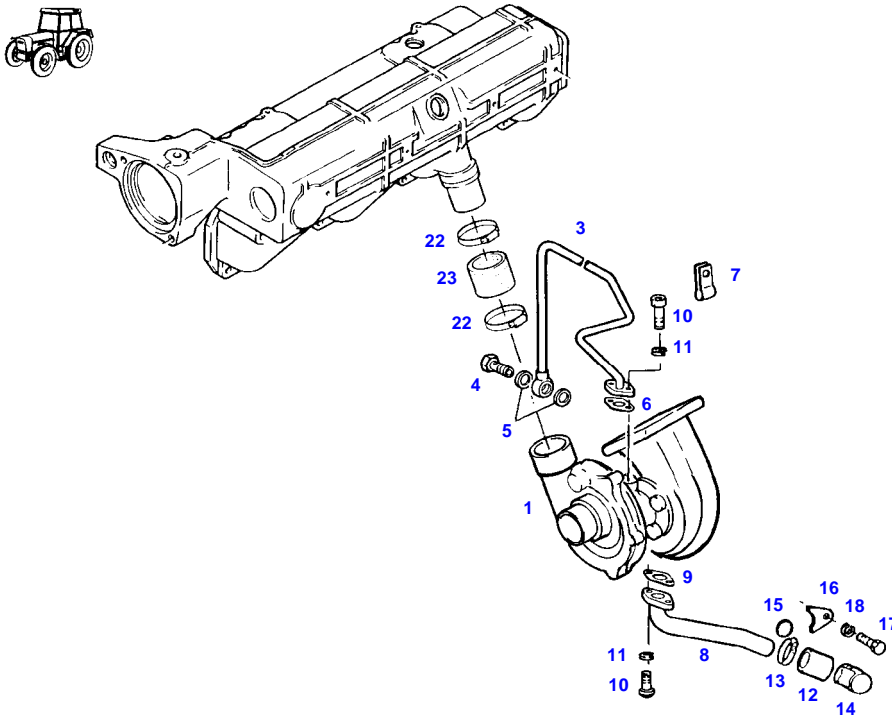

7692

Item	Part Number	Qty	Description Comments	Technical Specification
			<-- 192/20001	
1	72332433	1	TURBOCHARGER	
	72332434	1	SPARE PARTS KIT	
3	72332435	1	LUBE OIL LINE	
4	72374956	1	BANJO BOLT	DIN7623/3.70-A10-6.8
5	72315098	2	SEALING WASHER	DIN 7603 A16X22-CU
6	72332436	1	OVAL GASKET	
7	72332437	1	PIPE CLAMP	
8	72332438	1	LUBE OIL LINE	
9	72332161	1	OVAL GASKET	
10	72374020	2	SOCKET HEAD BOLT	DIN 912 M8X20-10.9
	72315474	2	SOCKET HEAD BOLT	
11	72315053	4	SPLIT WASHER	FWN 65208-8-A3L
12	72332160	1	HOSE PIECE	
13	72311167	2	HOSE CLIP	
14	72343888	1	MANIFOLD	
15	72343889	1	SEAL	
16	72343890	1	RETAINING SHEET METAL	
17	72315489	1	SOCKET HEAD BOLT	DIN 912-M8 X 16-8.8-A3L
18	72315053	1	SPLIT WASHER	FWN 65208-8-A3L
22	72311163	2	HOSE CLIP	
23	72332526	1	HOSE PIECE	

<https://www.ebooklibonline.com>

Hello dear friend!

Thank you very much for reading.

Enter the link into your browser.

The full manual is available for immediate download.

<https://www.ebooklibonline.com>