

<b>Page Number</b>	<b>Page Title</b>	<b>Page Reference</b>
01-000-TOC	ENGINE, FUEL AND EXHAUST SYSTEM	01-000-TOC
02-000-TOC	AXLES	02-000-TOC
03-000-TOC	STEERING SYSTEM	03-000-TOC
04-000-TOC	DRIVE TRAIN SYSTEM	04-000-TOC
05-000-TOC	COMPRESSED AIR SYSTEM	05-000-TOC
06-000-TOC	HYDRAULIC SYSTEM	06-000-TOC
07-000-TOC	ELECTRICAL SYSTEM	07-000-TOC
08-000-TOC	CAB	08-000-TOC
09-000-TOC	AIR CONDITIONING AND HEATING SYSTEM	09-000-TOC
10-000-TOC	CHASSIS	10-000-TOC
11-000-TOC	WHEELS	11-000-TOC
12-000-TOC	IMPLEMENT LIFT SYSTEM FRONT	12-000-TOC
13-000-TOC	IMPLEMENT LIFT SYSTEM REAR	13-000-TOC
14-000-TOC	FRONT/REAR LOADERS	14-000-TOC
15-000-TOC	ATTACHMENTS	15-000-TOC
16-000-TOC	ACCESSORIES	16-000-TOC

FARMER 309 (186/00001-11500)  
4267

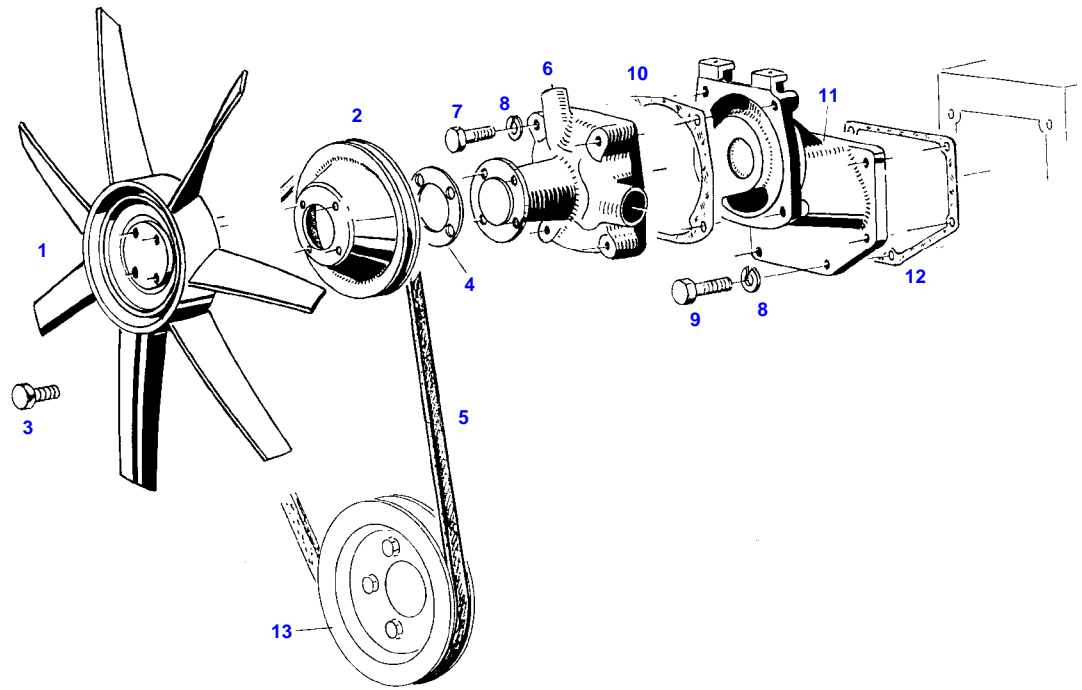

4267

Item	Part Number	Qty	Description Comments	Technical Specification
<b>RANGE OF TEMPERATURE 1</b>				
1	72331298	1	FAN	
2	72327206	1	V BELT SHEAVE	
3	72375063	4	LOCK SCREW	FWN 64993 M8X22-12.9
4	72394835	1	DISC	
5				
6	72340133	1	SEE ALTERNATOR ASSY CENTRIFUGAL PUMP --> 186/8000 <-- 186/9379 --> 178/10455	
	72343555	1	CENTRIFUGAL PUMP <-- 186/8001 --> 186/9378	
	72340135	1	REPAIR KIT --> 186/8000 <-- 186/9379 --> 178/10455 <-- F281.200.610.010	
	72343940	1	REPAIR KIT <-- 186/8001 --> 186/9378	
7	72315659	4	HEXAGONAL HEAD BOLT	DIN 933 M8X35-8.8
8	72315053	10	SPLIT WASHER	FWN 65208-8-A3L
9	72315654	6	HEXAGONAL HEAD BOLT	DIN 933 M8X28-8.8A3L
10	72328678	1	SEAL	
11	72330788	1	INTERMEDIATE PIECE --> 186/9378 <-- F162.204.610.010	
	72332585	1	INTERMEDIATE PIECE <-- 186/9379	
12			SEE CRANKCASE	
13			SEE CRANKSHAFT	

**<https://www.ebooklibonline.com>**

Hello dear friend!

Thank you very much for reading.

Enter the link into your browser.

The full manual is available for immediate download.

**<https://www.ebooklibonline.com>**

FARMER 309 (186/00001-11500)  
4267

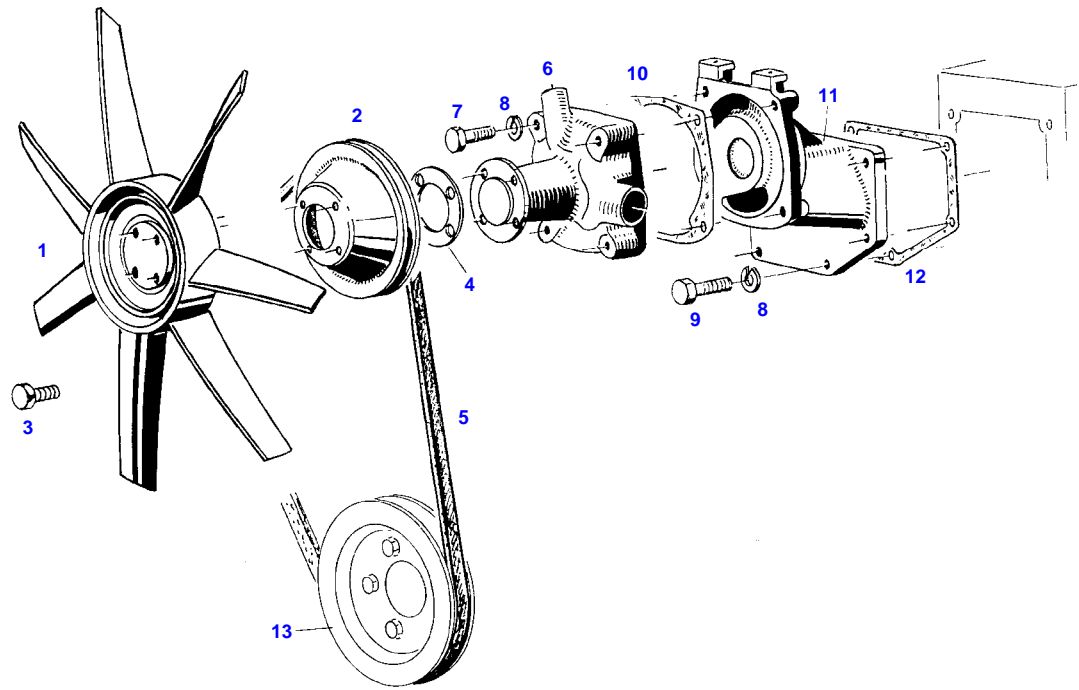

4267

Item	Part Number	Qty	Description Comments	Technical Specification
<b>RANGE OF TEMPERATURE 2</b>				
1	72380200	1	FAN	455/7
2	72399923	1	V BELT SHEAVE	
3	72375067	4	LOCK SCREW	FWN 64993 M8X35-90
4				
5			NOT USED	
6	72340133	1	SEE ALTERNATOR ASSY CENTRIFUGAL PUMP --> 186/8000 <-- 186/9379	
	72343555	1	CENTRIFUGAL PUMP <-- 186/8001 --> 186/9378	
	72340135	1	REPAIR KIT --> 186/8000 <-- 186/9379 <-- F281.200.610.010	
	72343940	1	REPAIR KIT <-- 186/8001 --> 186/9378	
7	72315659	4	HEXAGONAL HEAD BOLT	DIN 933 M8X35-8.8
8	72315053	10	SPLIT WASHER	FWN 65208-8-A3L
9	72315654	6	HEXAGONAL HEAD BOLT	DIN 933 M8X28-8.8A3L
10	72328678	1	SEAL	
11	72330788	1	INTERMEDIATE PIECE <-- F162.204.610.010	
12			SEE CRANKCASE	
13			SEE CRANKSHAFT	

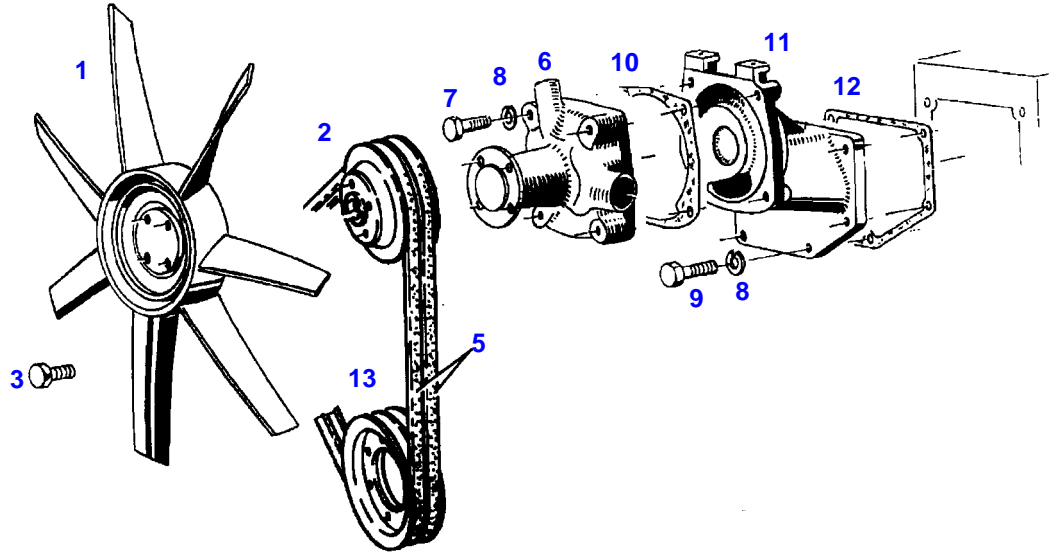

011160

Item	Part Number	Qty	Description Comments	Technical Specification
<b>AIR BRAKIN SYSTEM</b>				
1	72331298	1	FAN	
2	72393674	1	V BELT SHEAVE	
3	72375066	4	LOCK SCREW	FWN 64993-M8X30-90
5			SEE COMPRESSOR INSTALLAT	
6	72340133	1	CENTRIFUGAL PUMP --> 186/8000 <-- 186/9379	
	72343555	1	CENTRIFUGAL PUMP <-- 186/8001 --> 186/9378	
	72340135	1	REPAIR KIT --> 186/8000 <-- 186/9379 <-- F281.200.610.010	
	72343940	1	REPAIR KIT <-- 186/8001 --> 186/9378	
7	72315659	4	HEXAGONAL HEAD BOLT	DIN 933 M8X35-8.8
8	72315053	10	SPLIT WASHER	FWN 65208-8-A3L
9	72315654	6	HEXAGONAL HEAD BOLT	DIN 933 M8X28-8.8A3L
10	72328678	1	SEAL	
11	72330788	1	INTERMEDIATE PIECE <-- F162.204.610.010	
12			SEE CRANKCASE	
13			SEE COMPRESSOR INSTALLAT	

FARMER 309 (186/00001-11500)  
11170

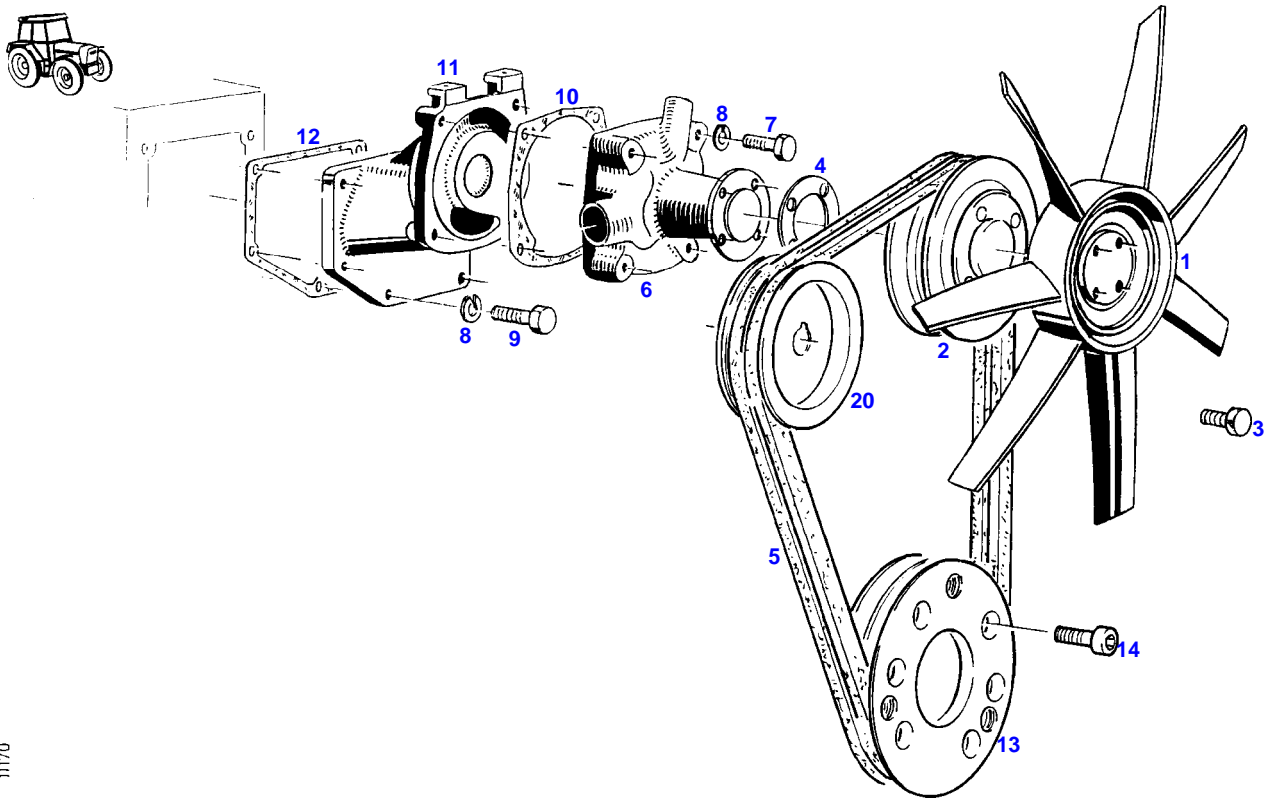

11170

Item	Part Number	Qty	Description Comments	Technical Specification
			<b>AIR CONDITION</b> <-- 186/8001	
1	72331298	1	FAN RANGE OF TEMPERATURE 1	
	72380200	1	FAN RANGE OF TEMPERATURE 2	455/7
2	72396003	1	V BELT SHEAVE	
3	72375063	4	LOCK SCREW RANGE OF TEMPERATURE 1	FWN 64993 M8X22-12.9
	72375067	4	LOCK SCREW RANGE OF TEMPERATURE 2	FWN 64993 M8X35-90
4	72394835	1	DISC RANGE OF TEMPERATURE 1	
5	72379399	1	V-BELT SET (2 PIECE)	FWN66966-2XAVX10X1215LA
6	72343555	1	CENTRIFUGAL PUMP	
	72343940	1	REPAIR KIT	
7	72315659	4	HEXAGONAL HEAD BOLT	DIN 933 M8X35-8.8
8	72315053	10	SPLIT WASHER	FWN 65208-8-A3L
9	72315654	6	HEXAGONAL HEAD BOLT	DIN 933 M8X28-8.8A3L
10	72328678	1	SEAL	
11	72332585	1	INTERMEDIATE PIECE	
12			SEE CRANKCASE	
13	72396002	1	V BELT SHEAVE	
14	72315498	6	SOCKET HEAD BOLT	DIN 912 M10X40-8.8 OB1-SW
20			SEE ALTERNATOR ASSY	

FARMER 309 (186/00001-11500)  
1603

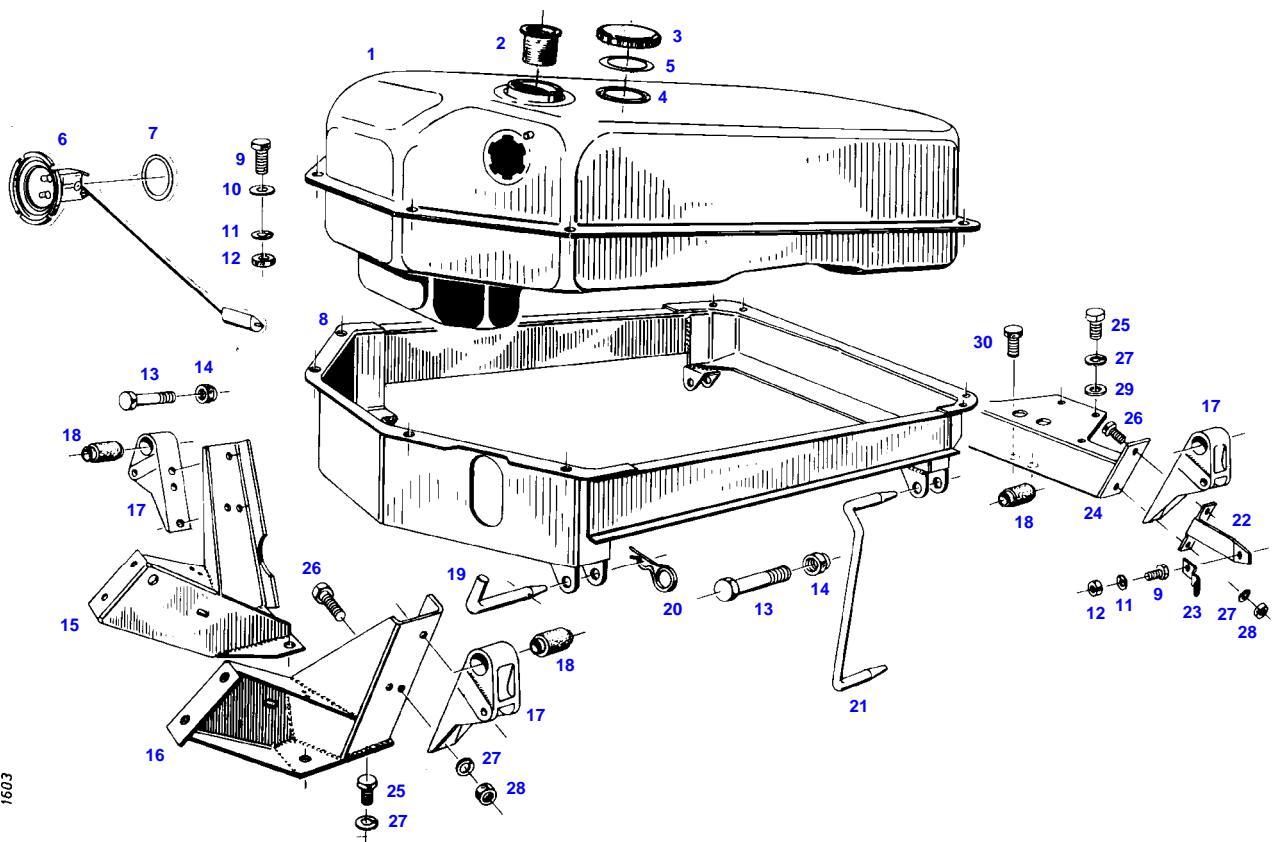

Item	Part Number	Qty	Description Comments	Technical Specification
			--> 186/4816	
1	72349985	1	FUEL TANK ><3 <>	
	72409022	2	FLANGE	
	72376132	2	SEALING WASHER	
	72376018	10	SEALING WASHER	DIN 7603 A5X9-VF
	72315619	10	HEXAGONAL HEAD BOLT	DIN 933 M5X16-8.8A3L
	72348556	1	FUEL LEVEL SENSOR	
	72376017	2	SEALING WASHER	DIN 7603-A5X7,5-CU
2	72380019	1	STRAINER 49MM --> 186/3281	
	72433112	1	STRAINER 99MM	60X100-MS
3	72348405	1	FUEL CAP ><4-5 BLAU <-- X810.110.050 1X	
	72348297	1	FUEL CAP ><4-5 LOCKABLE BLAU	
4	72312304	1	RUBBER SEAL KOEHLER	
	72330725	1	SEAL BLAU	
5	72330726	1	SEAL BLAU	
6	72613041	1	FUEL LEVEL SENSOR ><6-7	
7	72315169	1	SEALING WASHER	
8	72357106	1	TANK FRAME	
9	72315626	9	HEXAGONAL HEAD BOLT	DIN 933-M6 X 16-8.8-A3L
	72315631	2	HEXAGONAL HEAD BOLT	DIN 933 M6 X 20-8.8A3L
10	72311822	16	DISC	DIN9021-6,4-140HV-A3L
11	72315052	9	SPLIT WASHER	FWN 65208-6-A3L
12	72313266	9	NUT	DIN 934 M6-8A3L
13	72315719	2	HEXAGONAL HEAD BOLT	DIN 933 M12X60-8.8A3L
14	72313325	2	NUT	DIN 980-VM12-8-A3L
15	72355440	1	BRACKET	
16	72355441	1	BRACKET	
17	72356758	4	SUPPORT ARM <>	
	72315653	1	HEXAGONAL HEAD BOLT	DIN 933 M8 X 25-8.8A3L
	72313268	1	NUT	DIN 934 M8-8A3L
	72311788	1	DISC	DIN 125-8,4-ST.A3L
	72393683	1	ANGLE	
18	72310644	4	RUBBER BUSHING	
19	72407288	1	BEARING PIN	
20	72311183	1	HAIR COTTER PIN	DIN 11024-4-A3L
21	72393676	1	BEARING PIN	
	72393681	1	BEARING PIN WITH FRONTLOADER	
22	72393677	1	RETAINING BRACKET	
23	72393680	1	LEAF SPRING	
24	72355727	1	CROSSMEMBER	
25	72315642	8	HEXAGONAL HEAD BOLT	DIN 933 M8 X 16-8.8A3L
26	72315657	8	HEXAGONAL HEAD BOLT	DIN 933 M8 X 30-8.8A3L
27	72315053	16	SPLIT WASHER	FWN 65208-8-A3L
28	72313268	8	NUT	DIN 934 M8-8A3L
29	72311788	2	DISC	DIN 125-8,4-ST.A3L
30	72315675	2	HEXAGONAL HEAD BOLT	DIN 933 M10X16-8.8A3L

FARMER 309 (186/00001-11500)  
4920

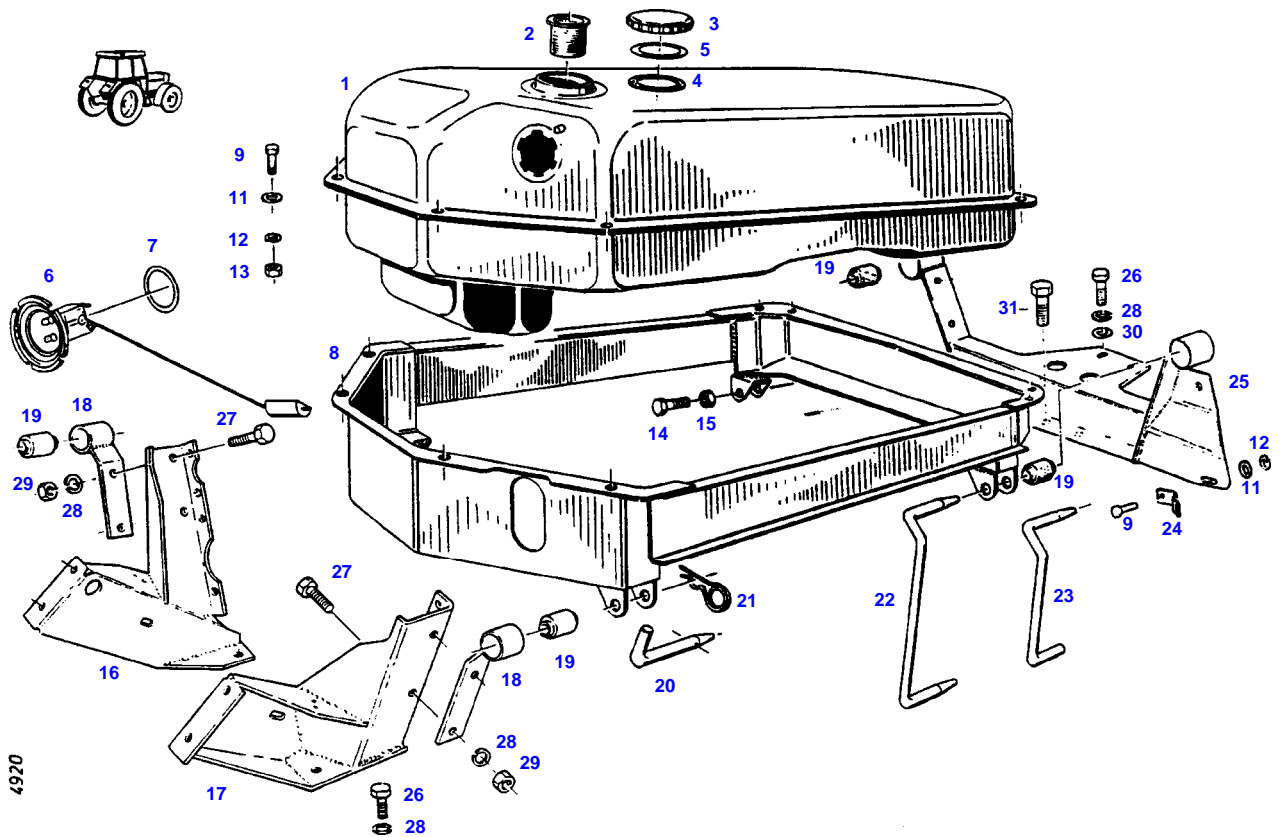

Item	Part Number	Qty	Description Comments	Technical Specification
			<-- 186/4817	
1	72349985	1	FUEL TANK <>	
	72348556	1	FUEL LEVEL SENSOR	
	72376018	8	SEALING WASHER	DIN 7603 A5X9-VF
2	72433112	1	STRAINER	60X100-MS
3	72380143	1	FUEL CAP KOEHLER	M.BELUEF
			><3+4	
	72348297	1	FUEL CAP LOCKABLE BLAU	
			><3-5	
4	72330725	1	SEAL BLAU	
	72312304	1	RUBBER SEAL KOEHLER	
5	72330726	1	SEAL BLAU	
6	72613041	1	FUEL LEVEL SENSOR	
7	72315169	1	SEALING WASHER	
8	72357106	1	TANK FRAME	
9	72315626	7	HEXAGONAL HEAD BOLT	DIN 933-M6 X 16-8.8-A3L
	72315631	2	HEXAGONAL HEAD BOLT	DIN 933 M6 X 20-8.8A3L
11	72311822	12	DISC	DIN9021-6,4-140HV-A3L
12	72315052	8	SPLIT WASHER	FWN 65208-6-A3L
13	72313266	8	NUT	DIN 934 M6-8A3L
14	72315719	2	HEXAGONAL HEAD BOLT	DIN 933 M12X60-8.8A3L
15	72313325	2	NUT	DIN 980-VM12-8-A3L
16	72355440	1	BRACKET	
17	72355441	1	BRACKET	
18	72356758	2	SUPPORT ARM	
19	72310644	4	RUBBER BUSHING	
20	72404932	1	BEARING PIN	
21	72311183	1	HAIR COTTER PIN	DIN 11024-4-A3L
22	72393676	1	BEARING PIN	
23	72393681	1	BEARING PIN	
24	72393680	1	LEAF SPRING	
25	72355727	1	CROSSMEMBER	
26	72315642	8	HEXAGONAL HEAD BOLT	DIN 933 M8 X 16-8.8A3L
27	72315657	4	HEXAGONAL HEAD BOLT	DIN 933 M8 X 30-8.8A3L
28	72315053	12	SPLIT WASHER	FWN 65208-8-A3L
29	72313268	4	NUT	DIN 934 M8-8A3L
30	72311788	2	DISC	DIN 125-8,4-ST.A3L
31	72315675	2	HEXAGONAL HEAD BOLT	DIN 933 M10X16-8.8A3L

FARMER 309 (186/00001-11500)  
1604

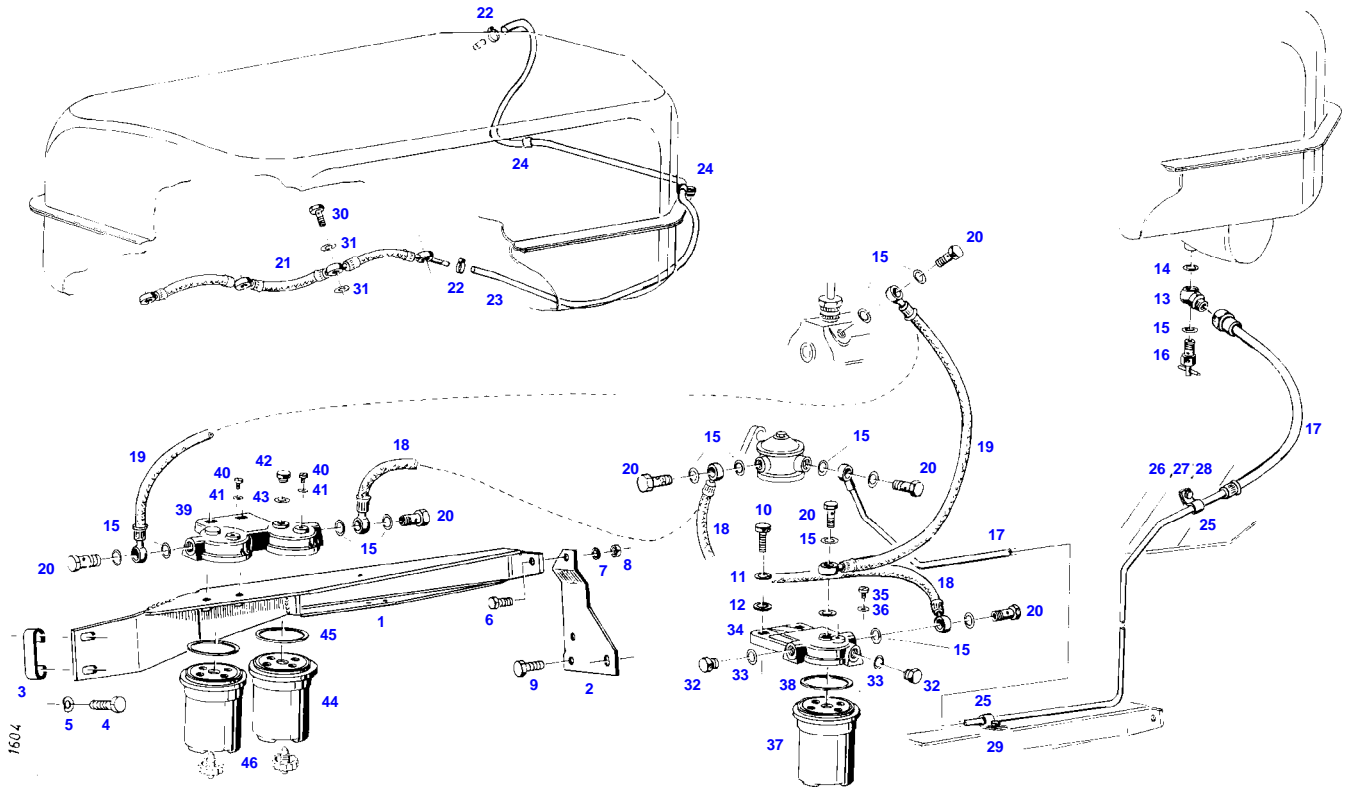

Item	Part Number	Qty	Description Comments	Technical Specification
			--> 186/8000	
1	72356706	1	RETAINER	
2	72393679	1	RETAINING SHEET METAL	
3	72399913	1	HOLDER	
4	72315689	1	HEXAGONAL HEAD BOLT	DIN 933 M10X35-8.8A3L
	72315691	1	HEXAGONAL HEAD BOLT	DIN 933 M10X40-8.8A3L
5	72317122	2	SPRING WASHER	DIN 137 B10-MECH.VZK
6	72315642	1	HEXAGONAL HEAD BOLT	DIN 933 M8 X 16-8.8A3L
7	72315053	1	SPLIT WASHER	FWN 65208-8-A3L
8	72313268	1	NUT	DIN 934 M8-8A3L
9	72374490	2	HEXAGONAL HEAD BOLT	DIN 933 M14X20-8.8
10	72315689	2	HEXAGONAL HEAD BOLT	DIN 933 M10X35-8.8A3L
11	72315054	2	SPLIT WASHER	FWN 65208-10-A3L
12	72311789	2	DISC	DIN 125-10,5-ST.A3L
13	72316302	1	NOZZLE	LL10 DIN7641/12.69 A3L
			--> 186/1926	
14	72315093	1	SEALING WASHER	DIN 7603 A12X18-CU
15	72315095	11	SEALING WASHER	DIN 7603 A14X20-CU
16	72380159	1	FUEL SHUT-OFF VALVE	
17	72348543	1	TUBING	
			--> 186/1926 <>	
			<>	
	72311241	2	PIPE CLAMP	
18	72365147	1	FUEL LINE	
19	72355537	1	FUEL LINE	
20	72315808	5	BANJO BOLT	DIN 7643-10-3-A3L
21	72339360	1	LEAKAGE OIL LINE	
22	72438345	2	HOSE CLIP	
23	72435830	1	PRESSURE HOSE	L=2100
			1150 MM	
			CUT TO LENGTH	
24	72398941	2	FASTENING COLLAR	
25	72373547	2	PIPE CLAMP	
			--> 186/1926	
	72311241	2	PIPE CLAMP	
			<-- 186/1927	
26	72315626	1	HEXAGONAL HEAD BOLT	DIN 933-M6 X 16-8.8-A3L
27	72315052	1	SPLIT WASHER	FWN 65208-6-A3L
	72311787	1	DISC	DIN 125-6,4-ST.A3L
28	72313266	1	NUT	DIN 934 M6-8A3L
29	72315629	1	HEXAGONAL HEAD BOLT	DIN 933 M6 X 12-8.8A3L
	72313266	1	NUT	DIN 934 M6-8A3L
	72315052	1	SPLIT WASHER	FWN 65208-6-A3L
30	72315809	4	BANJO BOLT	DIN 7643-4-5-A3L
31	72315086	8	SEALING WASHER	DIN 7603 A8X11,5-CU
32	72315799	2	PLUG	DIN 7604 AM14X1,5-A3L
33	72315095	2	SEALING WASHER	DIN 7603 A14X20-CU
34			SEE FUEL FILTER	
35			SEE FUEL FILTER	
36			SEE FUEL FILTER	
37			SEE FUEL FILTER	
38			SEE FUEL FILTER	
39			SEE FUEL FILTER	
40			SEE FUEL FILTER	
41			SEE FUEL FILTER	

---

Fendt

FARMER 309 (186/00001-11500)

F186000

FUEL LINES

Page01-0017

---

Item	Part Number	Qty	Description Comments	Technical Specification
42			SEE FUEL FILTER	
43			SEE FUEL FILTER	
44			SEE FUEL FILTER	
45			SEE FUEL FILTER	
46	72380174	1	SCREW	

FARMER 309 (186/00001-11500)  
40848

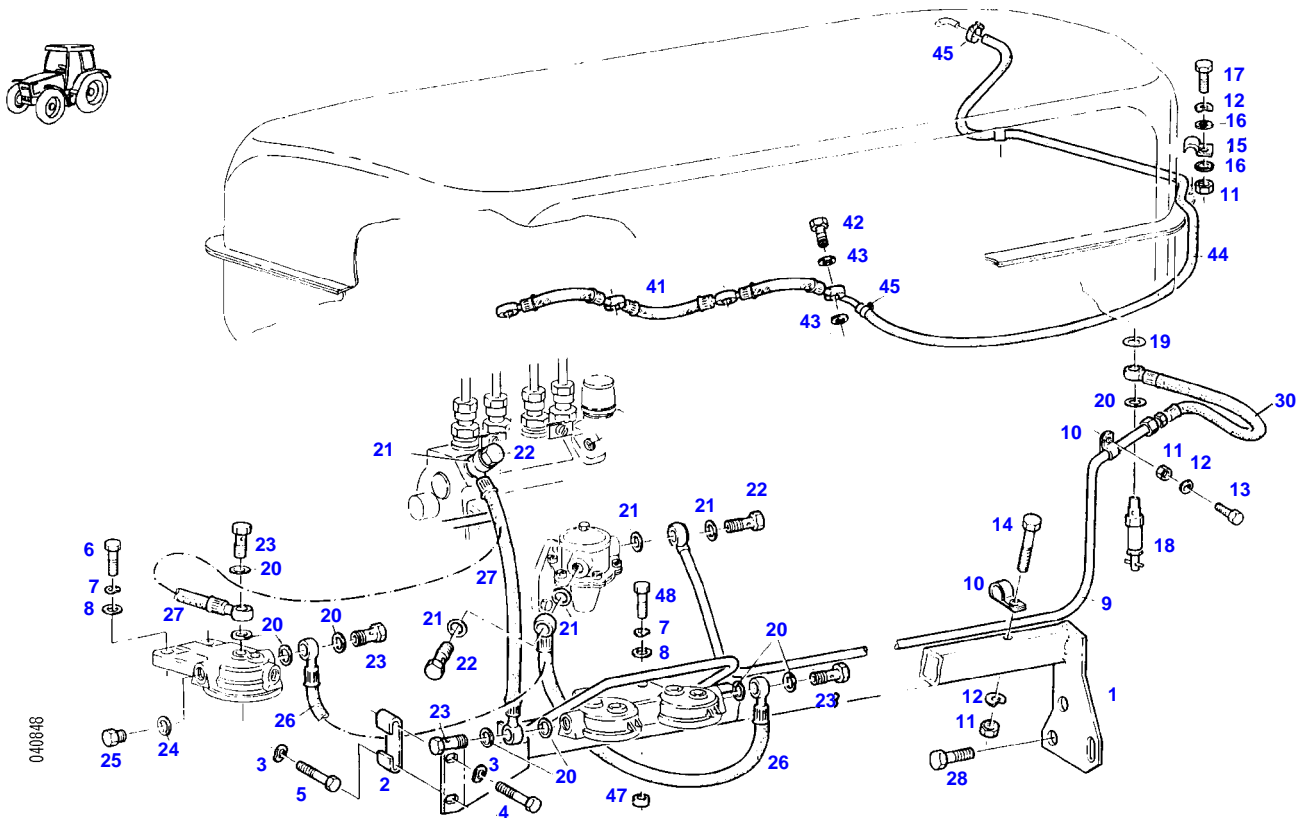

Item	Part Number	Qty	Description Comments	Technical Specification
			<-- 186/8001	
1	72356743	1	RETAINER	
2	72399913	1	HOLDER	
3	72317122	2	SPRING WASHER	DIN 137 B10-MECH.VZK
4	72315689	1	HEXAGONAL HEAD BOLT	DIN 933 M10X35-8.8A3L
5	72315691	1	HEXAGONAL HEAD BOLT	DIN 933 M10X40-8.8A3L
6	72315657	2	HEXAGONAL HEAD BOLT	DIN 933 M8 X 30-8.8A3L
7	72315053	2	SPLIT WASHER	FWN 65208-8-A3L
8	72311824	2	DISC	DIN9021-8,4-140HV-A3L
9	72356707	1	TUBING	
10	72311241	2	PIPE CLAMP	
11	72313266	3	NUT	DIN 934 M6-8A3L
12	72315052	3	SPLIT WASHER	FWN 65208-6-A3L
13	72315626	1	HEXAGONAL HEAD BOLT	DIN 933-M6 X 16-8.8-A3L
	72311787	1	DISC	DIN 125-6,4-ST.A3L
			NOT ILLUSTRATED	
14	72315637	1	HEXAGONAL HEAD BOLT	DIN 933 M6X45-8.8A3L
15	72398941	2	FASTENING COLLAR	
16	72311822	4	DISC	DIN9021-6,4-140HV-A3L
17	72315631	2	HEXAGONAL HEAD BOLT	DIN 933 M6 X 20-8.8A3L
18	72380159	1	FUEL SHUT-OFF VALVE	
19	72315093	1	SEALING WASHER	DIN 7603 A12X18-CU
20	72315095	5	SEALING WASHER	DIN 7603 A14X20-CU
21	72315095	6	SEALING WASHER	DIN 7603 A14X20-CU
22	72315808	3	BANJO BOLT	DIN 7643-10-3-A3L
23	72315808	2	BANJO BOLT	DIN 7643-10-3-A3L
24	72315095	2	SEALING WASHER	DIN 7603 A14X20-CU
25	72315799	2	PLUG	DIN 7604 AM14X1,5-A3L
26	72356760	1	FUEL LINE	
27	72355537	1	FUEL LINE	
28	72374490	2	HEXAGONAL HEAD BOLT	DIN 933 M14X20-8.8
	72374493	2	HEXAGONAL HEAD BOLT	DIN 933 M14X30-8.8
30	72357312	1	HOSE LINE	
41	72339360	1	LEAKAGE OIL LINE	
42	72315809	4	BANJO BOLT	DIN 7643-4-5-A3L
43	72315086	8	SEALING WASHER	DIN 7603 A8X11,5-CU
44	72378086	1	PRESSURE HOSE	FWN 66041-P4
45	72438345	2	HOSE CLIP	
47	72311848	2	DISC	
48	72315660	2	HEXAGONAL HEAD BOLT	DIN 933 M8X35-8.8A3L

FARMER 309 (186/00001-11500)  
4952

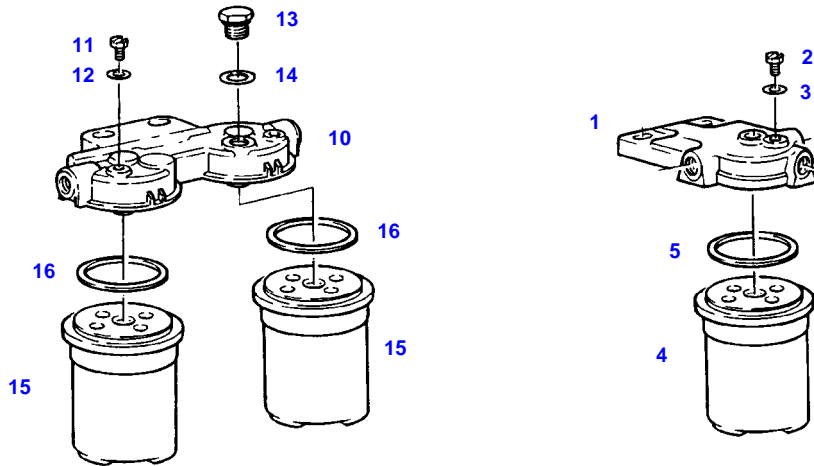

4952

Item	Part Number	Qty	Description Comments	Technical Specification
1	72615599	1	FILTER LID ><2,3	
2	72323290	1	BLEED SCREW	
3	72315084	1	SEALING WASHER	DIN 7603 A6X10-CU
4	72416928	1	FILTER BOX ><5	
5	72314995	1	RUBBER RING PARALLEL-FILTER	
10	72380173	1	PARALLEL FILTER BOSCH ><11-16 <-- X810.190.166.000 1X <>	
	72416928	2	FILTER BOX	
	72451307	1	COVER KNECHT ><11,12 <>	PARALLELFILT.
	72416928	2	FILTER BOX	
11	72323290	2	BLEED SCREW BOSCH	
	72314699	2	BLEED SCREW KNECHT	
12	72315084	2	SEALING WASHER BOSCH	DIN 7603 A6X10-CU
	72315086	2	SEALING WASHER KNECHT	DIN 7603 A8X11,5-CU
13	72326250	1	SCREW BOSCH	
14	72315095	1	SEALING WASHER BOSCH	DIN 7603 A14X20-CU
15	72416928	2	FILTER BOX ><16	
16	72314995	2	RUBBER RING	

FARMER 309 (186/00001-11500)  
3648

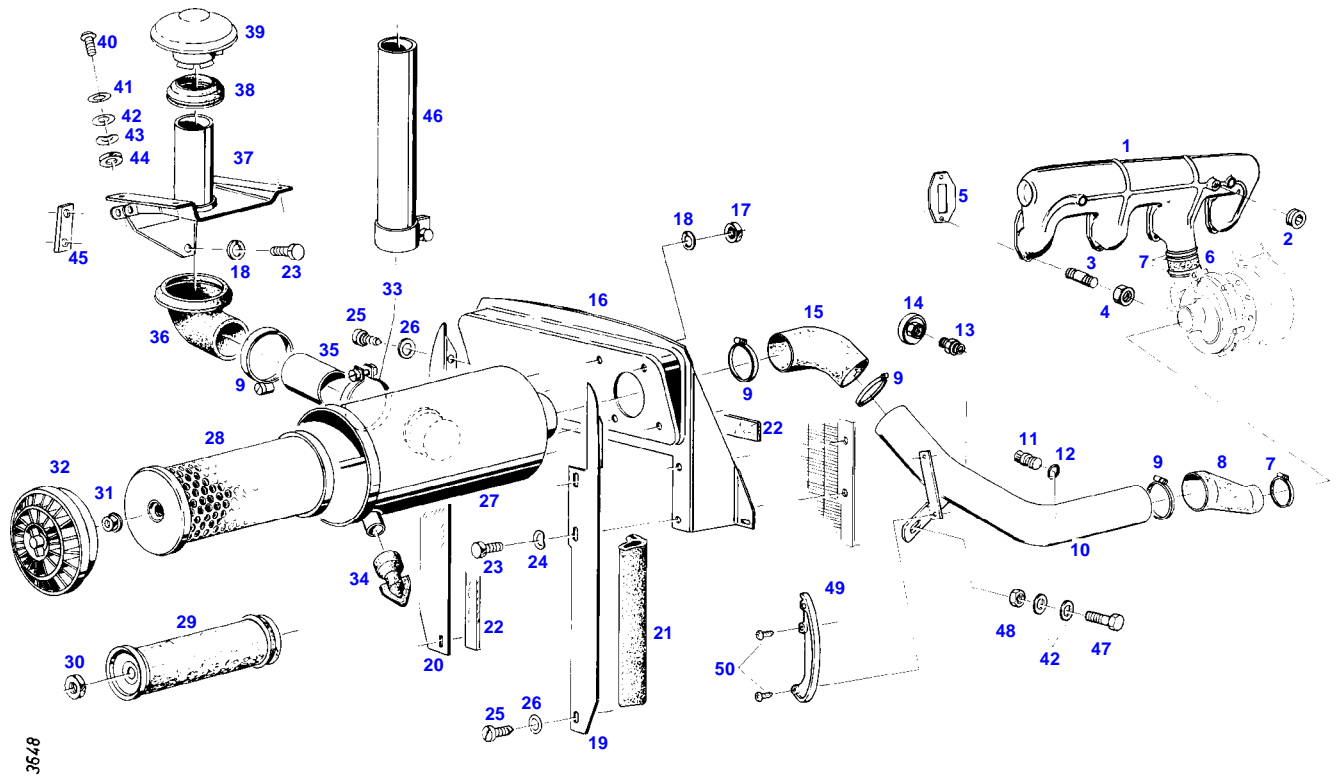

Item	Part Number	Qty	Description Comments	Technical Specification
			--> 186/9378	
1	72395914	1	INTAKE MANIFOLD --> 186/1926 <> <>	
	72373975	1	SCREW	DIN 910 M20X1,5-ST
	72376031	1	SEALING WASHER	DIN 7603 A20X24-CU
	72356711	1	INTAKE MANIFOLD --> 186/1926 WITH AIR BRAKING SYSTEM	
	72356715	1	INTAKE MANIFOLD <-- 186/1927 WITH AIR BRAKING SYSTEM	
2	72315433	1	SCREW	DIN 906 M14X1,5-ST
3	72373922	8	STUD BOLT	DIN 835-M10X25-8.8
4	72373015	8	NUT	DIN70615-M10-8-A3B
5	72332145	4	MOLDED SEAL	
6	72332139	1	HOSE PIECE	
7	72311163	4	HOSE CLIP	
8	72395415	1	REDUCER	
9	72373528	4	HOSE CLIP	
10	72356709	1	INTAKE MANIFOLD --> 186/1926	
	72356713	1	INTAKE MANIFOLD <-- 186/1927	
11	72373975	1	SCREW --> 186/1926	DIN 910 M20X1,5-ST
12	72376031	1	SEALING WASHER --> 186/1926	DIN 7603 A20X24-CU
13	72339032	1	THREADED SOCKET	
14	72316876	1	MAINTENANCE SWITCH --> 186/8246 <> <>	
	72380356	1	CABLE LUG	
	72314686	1	PLUG IN SLEEVE	
	72379171	0	WIRE	B1 DIN72551/6.51 SCHWARZ
	72380356	1	CABLE LUG	
	72314686	1	PLUG IN SLEEVE	
15	72395414	1	RUBBER ARCH	
16	72392142	1	FILTER BRACKET --> 186/9060 <> <>	
	72311787	1	DISC	DIN 125-6,4-ST.A3L
	72315052	1	SPLIT WASHER	FWN 65208-6-A3L
	72314744	1	LOCKING PLUG	F4
	72313266	1	NUT	DIN 934 M6-8A3L
	72315626	1	HEXAGONAL HEAD BOLT	DIN 933-M6 X 16-8.8-A3L
	72315626	1	HEXAGONAL HEAD BOLT <-- 186/9061	DIN 933-M6 X 16-8.8-A3L
	72313266	1	NUT <-- 186/9061	DIN 934 M6-8A3L
	72311787	1	DISC <-- 186/9061	DIN 125-6,4-ST.A3L
	72315052	1	SPLIT WASHER <-- 186/9061	FWN 65208-6-A3L
	72314744	1	LOCKING PLUG <-- 186/9061	F4
17	72313268	4	NUT	DIN 934 M8-8A3L
18	72315053	7	SPLIT WASHER	FWN 65208-8-A3L
19	72392834	1	SPLASH PANEL	
20	72392835	1	SPLASH PANEL	
21	72393692	1	SEALING PROFILE	
22			NO SPARE PART	
23	72315645	6	HEXAGONAL HEAD BOLT	DIN 933 M8 X 12-8.8A3L



**Suggest:**

**For more complete manuals. Please go to the home page.**

**<https://www.ebooklibonline.com>**

**If the above button click is invalid. Please download this document first, and then click the above link to download the complete manual.**

**Thank you so much for reading**

Item	Part Number	Qty	Description Comments	Technical Specification
24	72317121	3	SPRING WASHER	DIN 137 B8-MECH.VZK
25	72315785	4	SCREW	DIN 7981 ST4,2X9,5-C-H-A3
26	72311817	4	DISC	DIN9021-4,3-140HV-A3L
27	72348100	1	AIR FILTER ><28-34 NOT AVAILABLE IN SINGLE PARTS	
28	72329734	1	MICRO-TOP CARTRIDGE	
29	72329735	1	SAFETY CARTRIDGE	
30	72372827	1	NUT	DIN 934 M16X1,5-10A3L
31	72339030	1	COLLAR NUT	
32	72329736	1	FLOOR	
	72395403	1	ABSORPTION INDICATOR	
33	72329737	1	PIPE CLAMP <-- X458.648.500.000	
34	72326122	1	DUST DISCHARGE VALVE	
35	72393687	1	CONNECTING PIPE	
36	72393688	1	BELLOWS	
37	72355730	1	AIR INTAKE	
38	72393690	1	SEALING RING	
39	72330730	1	RAIN CAP	
40	72373806	4	TRUSS HEAD SCREW	DIN 603 M6X16-A3L
41	72311788	4	DISC	DIN 125-8,4-ST.A3L
42	72311787	6	DISC	DIN 125-6,4-ST.A3L
43	72315052	4	SPLIT WASHER	FWN 65208-6-A3L
44	72313266	4	NUT	DIN 934 M6-8A3L
45	72393790	1	THREADED PLATE	
46			NO LONGER AVAILABLE	
47	72315630	1	HEXAGONAL HEAD BOLT	DIN 933 M6X18-8.8A3L
48	72313318	1	NUT	DIN6925-M6-8-A3L
49	72395417	1	SKID <-- 186/0093	
50	72315814	2	SCREW <-- 186/0093	DIN7976-ST4,8X16-F-A3L

FARMER 309 (186/00001-11500)  
2794

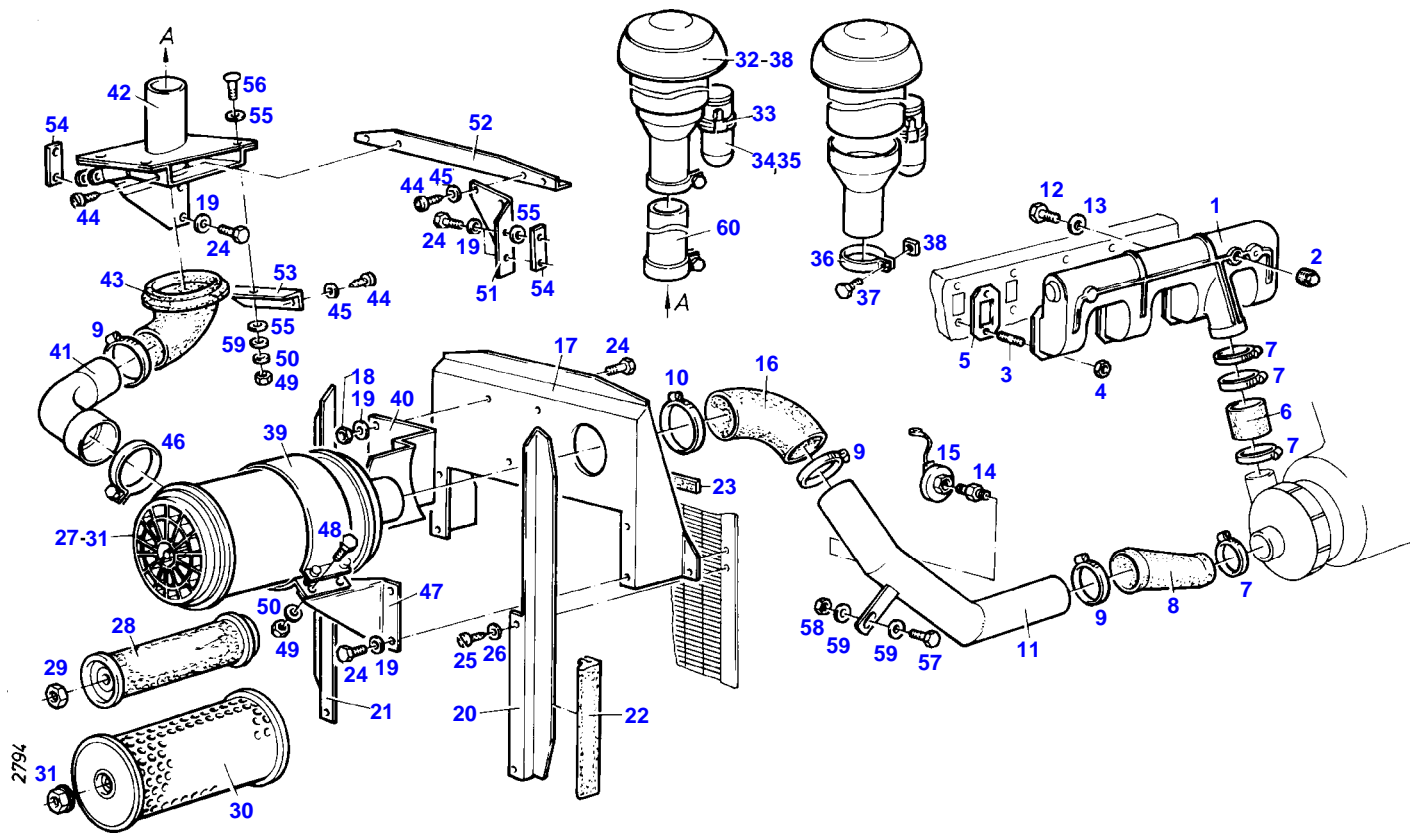

**<https://www.ebooklibonline.com>**

Hello dear friend!

Thank you very much for reading.

Enter the link into your browser.

The full manual is available for immediate download.

**<https://www.ebooklibonline.com>**