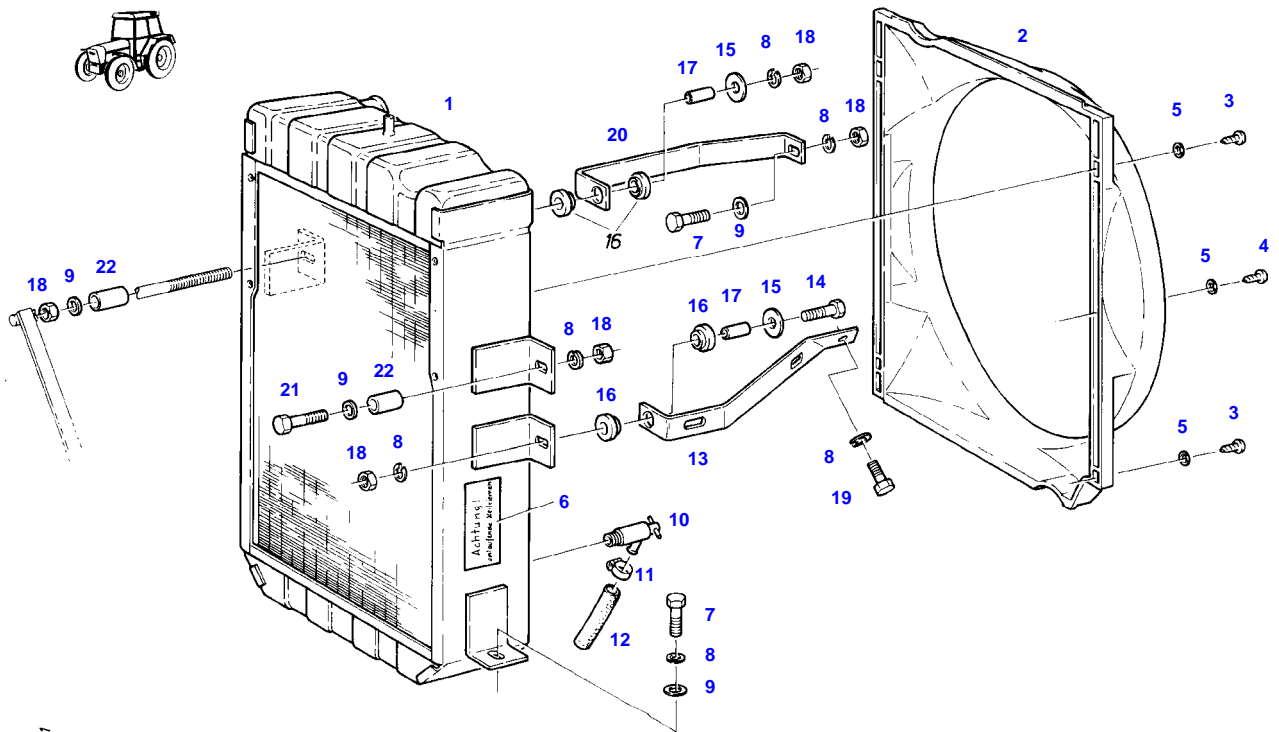

TABLE OF CONTENT

Page Number	Page Title	Page Reference
01-000-TOC	ENGINE, FUEL AND EXHAUST SYSTEM	01-000-TOC
02-000-TOC	AXLES	02-000-TOC
03-000-TOC	STEERING SYSTEM	03-000-TOC
04-000-TOC	DRIVE TRAIN SYSTEM	04-000-TOC
05-000-TOC	COMPRESSED AIR SYSTEM	05-000-TOC
06-000-TOC	HYDRAULIC SYSTEM	06-000-TOC
07-000-TOC	ELECTRICAL SYSTEM	07-000-TOC
08-000-TOC	CAB	08-000-TOC
09-000-TOC	AIR CONDITIONING AND HEATING SYSTEM	09-000-TOC
10-000-TOC	CHASSIS	10-000-TOC
11-000-TOC	WHEELS	11-000-TOC
12-000-TOC	IMPLEMENT LIFT SYSTEM FRONT	12-000-TOC
13-000-TOC	IMPLEMENT LIFT SYSTEM REAR	13-000-TOC
14-000-TOC	FRONT/REAR LOADERS	14-000-TOC
15-000-TOC	ATTACHMENTS	15-000-TOC
16-000-TOC	ACCESSORIES	16-000-TOC

FARMER 307 (175/00001-00800)
6331



Item	Part Number	Qty	Description Comments	Technical Specification
1	72348232	1	RADIATOR RANGE OF TEMPERATURE 1+2 / 1+2 WITH AIR BRAKE SUPPLY EQUIPEMENT <-- G186.205.050.010 1X AIR BRAKE SUPPLY EQUIPEMENT <>	
	72315663	1	HEXAGONAL HEAD BOLT	DIN 933 M8X40-8.8A3L
	72395450	1	BRACKET	
	72400314	1	BUSH	
	72348553	1	RADIATOR TEMP.RANGE 1 WITH AIR CONDITION RANGE OF TEMPERATURE 1+2 WITH AIR TEMP.RANGE 1 WITH AIR CONDITION KLIMAAANLAGE 1 M.KLIMAAANLAGE	
2	72393668	1	FAN COVER	
3	72315818	4	SCREW	DIN7976-ST4,2X25-C-A3L
4	72315787	2	SCREW	DIN 7981 B4,2X16-A3L
5	72311817	6	DISC	DIN9021-4,3-140HV-A3L
6	72386100	2	WARNING SIGN D	
	72388085	2	WARNING SIGN GB	
	72388086	2	WARNING SIGN F	
	72388087	2	WARNING SIGN I	
	72388088	2	WARNING SIGN E	
7	72315650	3	HEXAGONAL HEAD BOLT	DIN 933 M8 X 20-8.8A3L
8	72315053	7	SPLIT WASHER	FWN 65208-8-A3L
9	72311788	5	DISC	DIN 125-8,4-ST.A3L
10	72378063	1	RELIEF VALVE	DIN71401-CM14X1,5KEG
11	72438345	1	HOSE CLIP	
12	72389310	1	HOSE	
13	72395409	1	BRACE	
14	72315660	1	HEXAGONAL HEAD BOLT	DIN 933 M8X35-8.8A3L
15	72311888	2	DISC	
16	72312479	4	UNIVERSAL SPOUT	
17	72310718	2	BUSH	
18	72313268	5	NUT	DIN 934 M8-8A3L
19	72315653	1	HEXAGONAL HEAD BOLT	DIN 933 M8 X 25-8.8A3L
20	72393671	1	BRACE	
21	72315650	1	HEXAGONAL HEAD BOLT RANGE OF TEMPERATURE 1+2 / 1+2 WITH AIR BRAKE SUPPLY EQUIPEMENT AIR BRAKE SUPPLY EQUIPEMENT	DIN 933 M8 X 20-8.8A3L
	72315663	1	HEXAGONAL HEAD BOLT TEMP.RANGE 1 WITH AIR CONDITION RANGE OF TEMPERATURE 1+2 WITH AIR TEMP.RANGE 1 WITH AIR CONDITION KLIMAAANLAGE 1 M.KLIMAAANLAGE	DIN 933 M8X40-8.8A3L
22	72400314	2	BUSH TEMP.RANGE 1 WITH AIR CONDITION RANGE OF TEMPERATURE 1+2 WITH AIR TEMP.RANGE 1 WITH AIR CONDITION KLIMAAANLAGE 1 M.KLIMAAANLAGE	

<https://www.ebooklibonline.com>

Hello dear friend!

Thank you very much for reading.

Enter the link into your browser.

The full manual is available for immediate download.

<https://www.ebooklibonline.com>

FARMER 307 (175/00001-00800)
6336

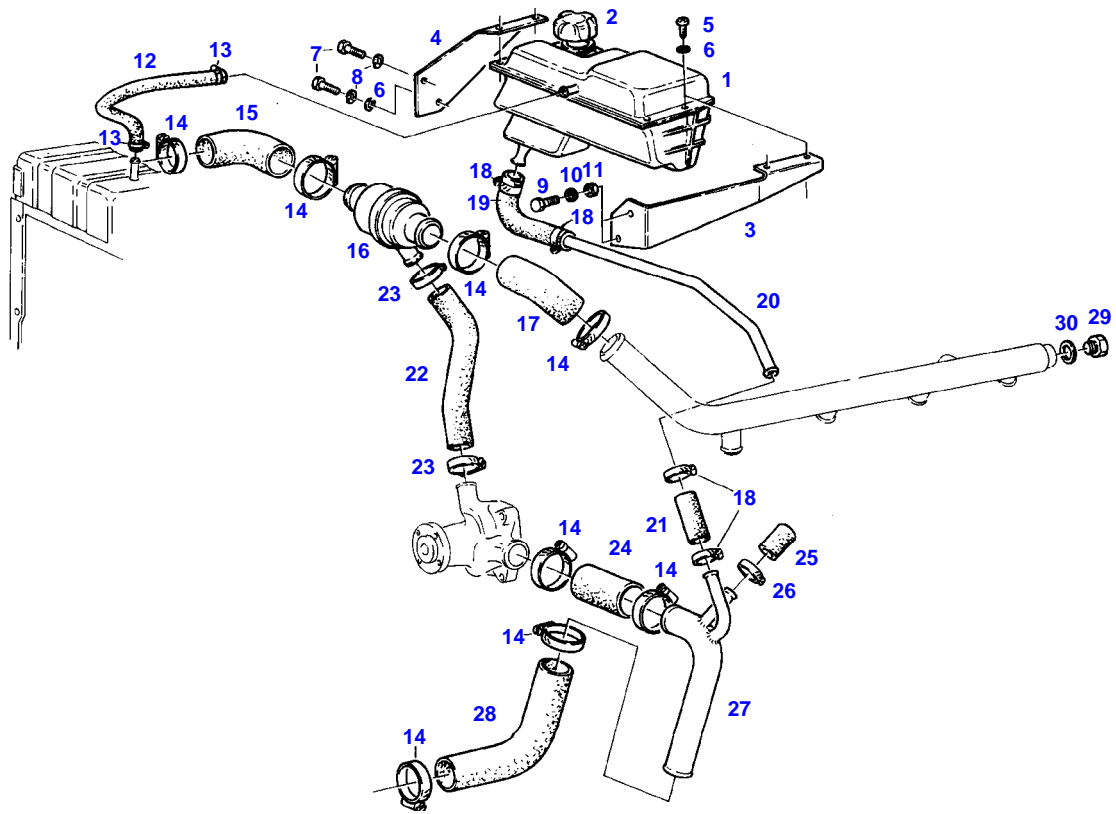

6336

Item	Part Number	Qty	Description Comments	Technical Specification
1	72316897	1	EXPANSION TANK <>	
	72409370	1	CAP	
	72438345	1	HOSE CLIP	
2	72348672	1	COLLER LOCKING	
3	72392987	1	BRACKET RANGE OF TEMPERATURE 1+2 / 1+2 WITH AIR BRAKE SUPPLY EQUIPEMENT AIR BRAKE SUPPLY EQUIPEMENT	
	72395450	1	BRACKET TEMP.RANGE 1 WITH AIR CONDITION RANGE OF TEMPERATURE 1+2 WITH AIR TEMP.RANGE 1 WITH AIR CONDITION KLIMAANLAGE 1 M.KLIMAANLAGE	
4	72392988	1	BRACKET	
5	72315821	4	SCREW	DIN7976-ST6,3X19-C-A3L
6	72311822	5	DISC	DIN9021-6,4-140HV-A3L
7	72315629	2	HEXAGONAL HEAD BOLT	DIN 933 M6 X 12-8.8A3L
8	72315052	2	SPLIT WASHER	FWN 65208-6-A3L
9	72315642	2	HEXAGONAL HEAD BOLT	DIN 933 M8 X 16-8.8A3L
10	72315053	2	SPLIT WASHER	FWN 65208-8-A3L
11	72313268	2	NUT	DIN 934 M8-8A3L
12	72622024	1	PRESSURE HOSE 1X 185MM CUT TO LENGTH	L=0,50M 8X3,5-FWN65911
13	72438345	2	HOSE CLIP	
14	72311162	8	HOSE CLIP	
15	72393666	1	RUBBER ARCH	
16	72380193	1	THERMOSTAT	75GR+-2GR
17	72392140	1	RUBBER ARCH	
18	72311166	4	HOSE CLIP	
19	72435869	1	RUBBER ARCH	
20	72392830	1	PIPE	
21	72450412	1	HOSE 1X 50MM CUT TO LENGTH	L=1000 18X3,5 R DIN 73411
22	72436027	1	HOSE 1X 120MM CUT TO LENGTH	L=320 DIN73411-25X3,5 R
23	72311167	2	HOSE CLIP	
24	72393672	1	REDUCER	
25	72404925	1	CAP	
26	72311166	1	HOSE CLIP	
27	72357308	1	SUCTION LINE	
28	72395412	1	RUBBER ARCH	
29	72315802	1	SCREW	DIN 7604 AM22X1,5-ST
30	72315101	1	SEALING WASHER	DIN 7603 A22X27-CU

FARMER 307 (175/00001-00800)
5179

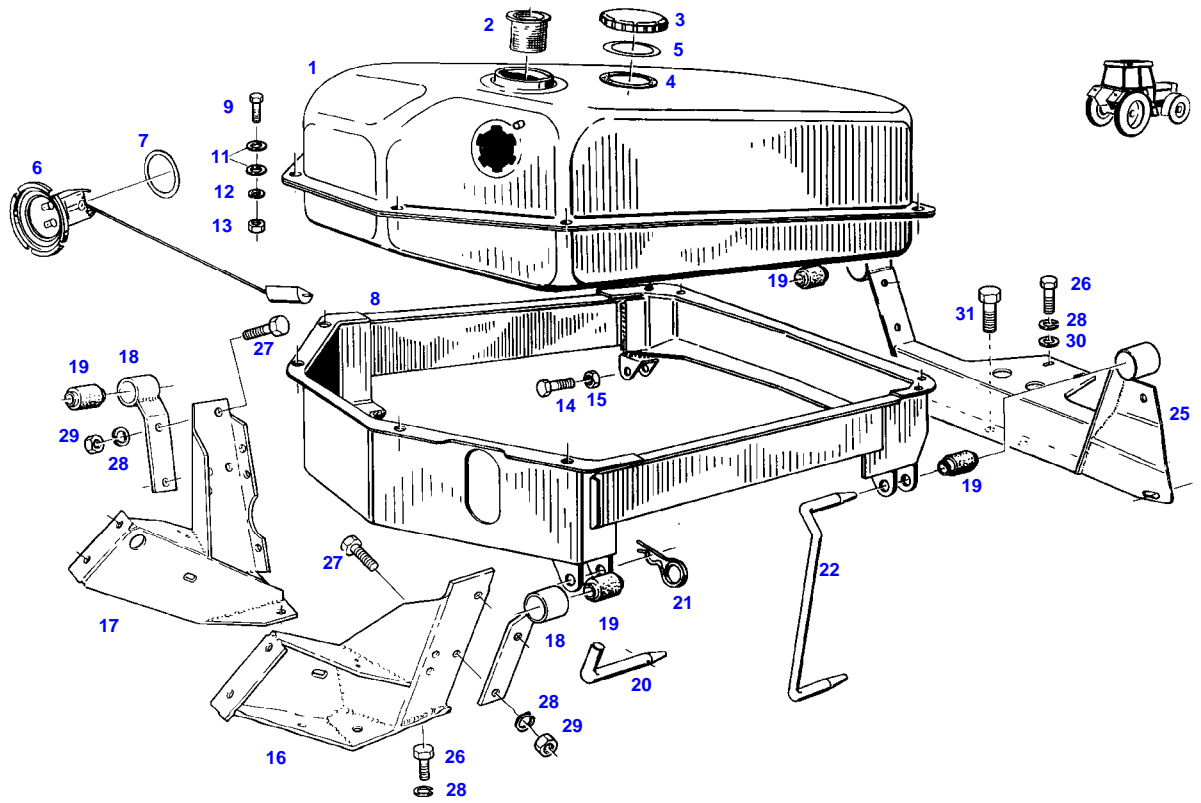

5179

Item	Part Number	Qty	Description Comments	Technical Specification
1	72348236	1	FUEL TANK <>	
	72348556	1	FUEL LEVEL SENSOR	
2	72433112	1	STRAINER	60X100-MS
3	72380143	1	FUEL CAP KOEHLER ><4	M.BELUEF
	72348297	1	FUEL CAP LOCKABLE BLAU ><4+5	
4	72330725	1	SEAL BLAU	
	72312304	1	RUBBER SEAL KOEHLER	
5	72330726	1	SEAL BLAU	
6	72613041	1	FUEL LEVEL SENSOR ><7	
7	72315169	1	SEALING WASHER	
8	72355536	1	TANK FRAME	
9	72315626	8	HEXAGONAL HEAD BOLT	DIN 933-M6 X 16-8.8-A3L
11	72311822	16	DISC	DIN9021-6,4-140HV-A3L
12	72315052	8	SPLIT WASHER	FWN 65208-6-A3L
13	72313266	8	NUT	DIN 934 M6-8A3L
14	72315719	2	HEXAGONAL HEAD BOLT	DIN 933 M12X60-8.8A3L
15	72313325	2	NUT	DIN 980-VM12-8-A3L
16	72355440	1	BRACKET	
17	72355441	1	BRACKET	
18	72356758	2	SUPPORT ARM	
19	72310644	4	RUBBER BUSHING	
20	72404932	2	BEARING PIN	
21	72311183	2	HAIR COTTER PIN	DIN 11024-4-A3L
22	72393676	1	BEARING PIN	
25	72355727	1	CROSSMEMBER	
26	72315642	8	HEXAGONAL HEAD BOLT	DIN 933 M8 X 16-8.8A3L
27	72315653	4	HEXAGONAL HEAD BOLT	DIN 933 M8 X 25-8.8A3L
28	72315053	12	SPLIT WASHER	FWN 65208-8-A3L
29	72313268	4	NUT	DIN 934 M8-8A3L
30	72311788	2	DISC	DIN 125-8,4-ST.A3L
31	72315675	2	HEXAGONAL HEAD BOLT	DIN 933 M10X16-8.8A3L

FARMER 307 (175/00001-00800)
6337

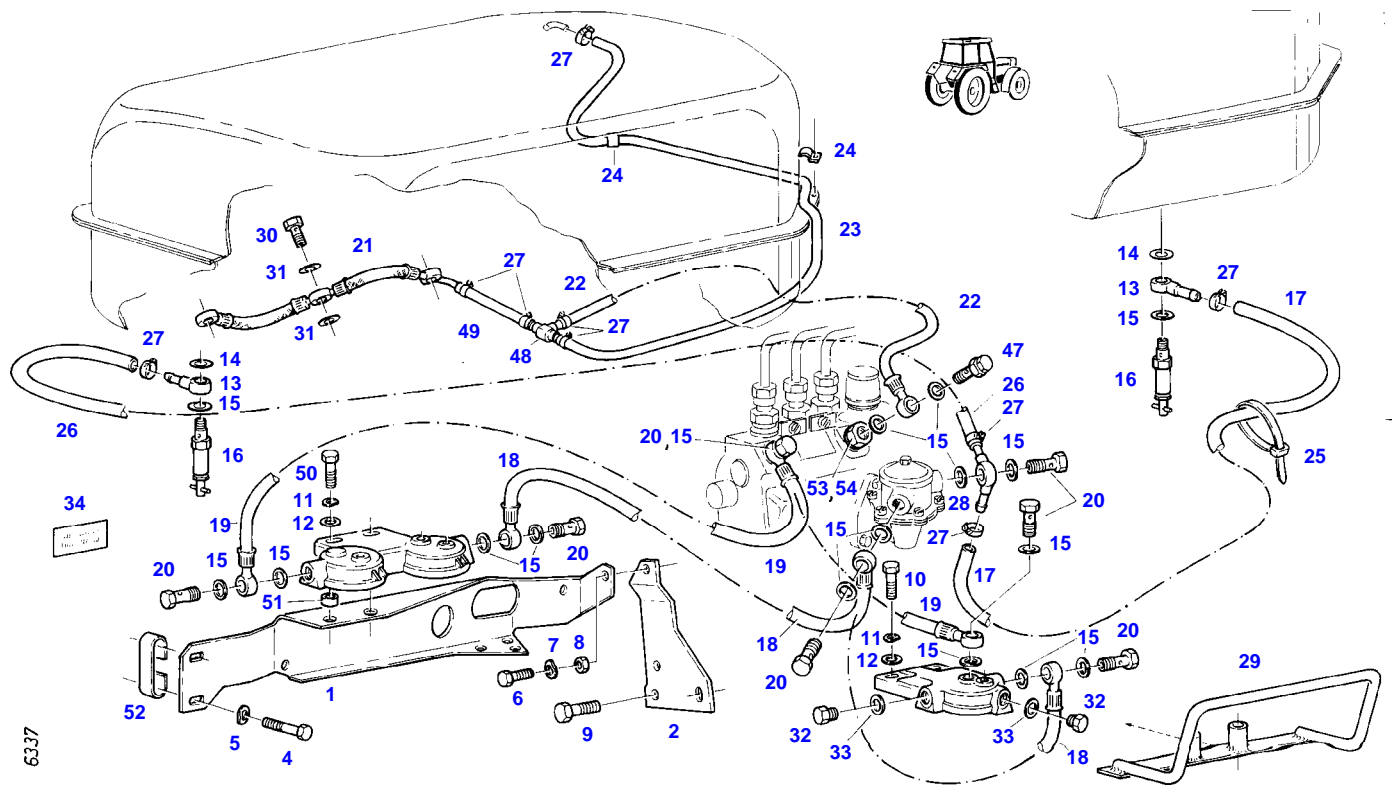

Item	Part Number	Qty	Description Comments	Technical Specification
1	72354920	1	FILTER RETAINER	
2	72393679	1	RETAINING SHEET METAL	
4	72315691	1	HEXAGONAL HEAD BOLT	DIN 933 M10X40-8.8A3L
	72315689	1	HEXAGONAL HEAD BOLT	DIN 933 M10X35-8.8A3L
5	72317122	2	SPRING WASHER	DIN 137 B10-MECH.VZK
6	72315642	1	HEXAGONAL HEAD BOLT	DIN 933 M8 X 16-8.8A3L
7	72315053	1	SPLIT WASHER	FWN 65208-8-A3L
8	72313268	1	NUT	DIN 934 M8-8A3L
9	72374490	2	HEXAGONAL HEAD BOLT	DIN 933 M14X20-8.8
	72374493	2	HEXAGONAL HEAD BOLT	DIN 933 M14X30-8.8
10	72315547	2	HEXAGONAL HEAD BOLT	DIN 931 M10X60-8.8A3L
	72315681	2	HEXAGONAL HEAD BOLT	DIN 933 M10X25-8.8A3L
11	72315054	2	SPLIT WASHER	FWN 65208-10-A3L
12	72311789	2	DISC	DIN 125-10,5-ST.A3L
13	72377531	2	RING HOSE NIPPLE	FWN65910-A-DN8
14	72315093	2	SEALING WASHER	DIN 7603 A12X18-CU
15	72315095	14	SEALING WASHER	DIN 7603 A14X20-CU
16	72380159	2	FUEL SHUT-OFF VALVE	
17	72450303	1	PRESSURE HOSE 980 MM CUT TO LENGTH	L=1000
18	72356760	1	FUEL LINE	
19	72355537	1	FUEL LINE	
20	72315808	4	BANJO BOLT	DIN 7643-10-3-A3L
21	72329530	1	LEAKAGE OIL LINE	
22	72356761	1	FUEL LINE	
23	72378086	-	PRESSURE HOSE	FWN 66041-P4
24	72398941	2	FASTENING COLLAR	
25	72316916	3	CABLE STRAP	FWN 66650 B175X4-SW
26	72450303	1	PRESSURE HOSE 880 MM CUT TO LENGTH	L=1000
27	72438345	4	HOSE CLIP	
	72438345	5	HOSE CLIP	
28	72377533	1	DOUBLE NIPPLE	FWN65910-DN8-120GR
29	72355462	1	HOLDER	
30			NOT USED	
31			NOT USED	
32	72315799	2	PLUG	DIN 7604 AM14X1,5-A3L
33	72315095	2	SEALING WASHER	DIN 7603 A14X20-CU
34	72393682	1	MARKING PLATE ARABIAN-ENGLISH	
47	72380268	1	BLEED AND DRAIN VALVE	
48	72380023	1	TEE FITTING	
49	72450301	1	PRESSURE HOSE 150 MM CUT TO LENGTH	L=1000
51	72310738	2	BUSH	
52	72399913	1	HOLDER	
53			NOT USED	
54			NOT USED	

FARMER 307 (175/00001-00800)
4952

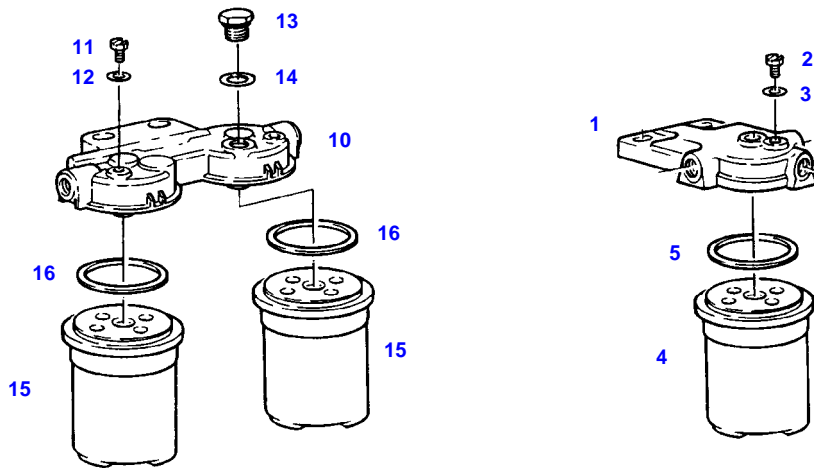

4952

Item	Part Number	Qty	Description Comments	Technical Specification
1	72615599	1	FILTER LID ><2,3	
2	72323290	1	BLEED SCREW	
3	72315084	1	SEALING WASHER	DIN 7603 A6X10-CU
4	72416928	1	FILTER BOX ><5	
5	72314995	1	RUBBER RING PARALLEL-FILTER	
10	72380173	1	PARALLEL FILTER BOSCH ><11-16 <-- X810.190.166.000 1X <>	
	72416928	2	FILTER BOX	
	72451307	1	COVER KNECHT ><11-12 <>	PARALLELFILT.
	72416928	2	FILTER BOX	
11	72323290	2	BLEED SCREW BOSCH	
	72314699	2	BLEED SCREW KNECHT	
12	72315084	2	SEALING WASHER BOSCH	DIN 7603 A6X10-CU
	72315086	2	SEALING WASHER KNECHT	DIN 7603 A8X11,5-CU
13	72326250	1	SCREW BOSCH	
14	72315095	1	SEALING WASHER BOSCH	DIN 7603 A14X20-CU
15	72416928	2	FILTER BOX ><16	
16	72314995	2	RUBBER RING	

FARMER 307 (175/00001-00800)
F060726

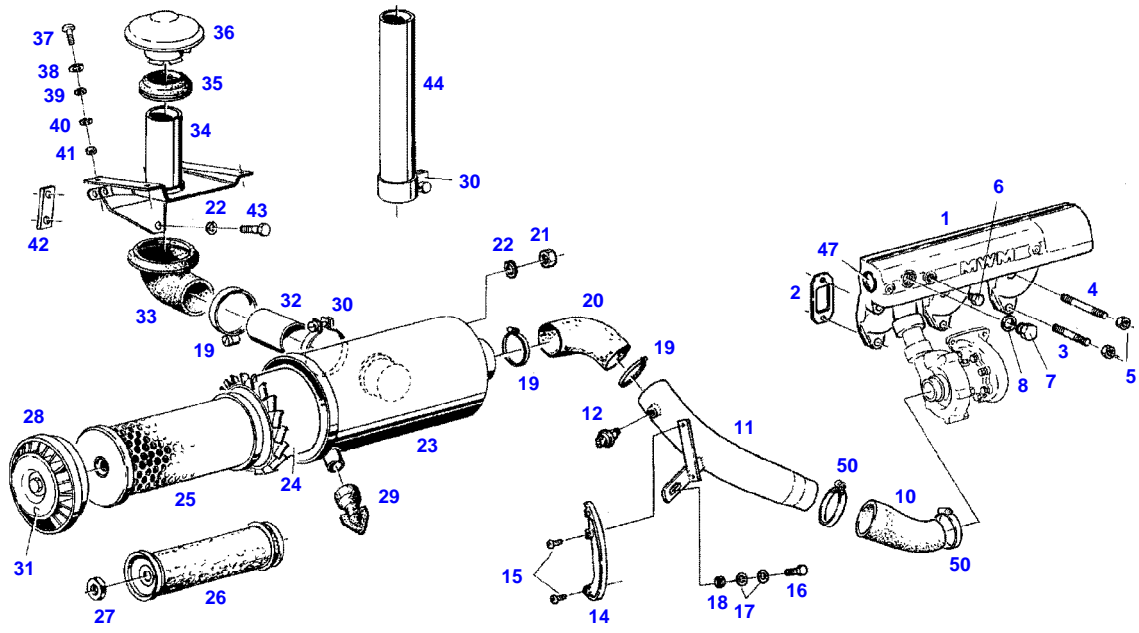

F060726



Item	Part Number	Qty	Description Comments	Technical Specification
PICLON				
1	72392836	1	INTAKE MANIFOLD	
2	72332145	3	MOLDED SEAL	
3	72374648	3	STUD BOLT	DIN 939 M10X40-10.9
4	72374654	3	STUD BOLT	DIN 939 M10X70-10.9
5	72373015	6	NUT	DIN70615-M10-8-A3B
6	72315433	1	SCREW	DIN 906 M14X1,5-ST
7	72373975	1	SCREW	DIN 910 M20X1,5-ST
8	72376031	1	SEALING WASHER	DIN 7603 A20X24-CU
9	72311170	1	HOSE CLIP	
10	72392837	1	RUBBER ARCH	
			<>	
	72492958	1	HOSE CLIP	59-83
11	72355443	1	INTAKE MANIFOLD	
	72420664	1	BOLT	
			AIR BRAKING SYSTEM	
	72436024	1	HOSE	L=920 DIN73411-15X3,5 R
			AIR BRAKING SYSTEM	
			1X 50MM	
	72311166	2	HOSE CLIP	
			AIR BRAKING SYSTEM	
12	72316876	1	MAINTENANCE SWITCH	
			MANN & HUMMEL	
	72379896	1	MAINTENANCE SWITCH	
			KNECHT	
14	72395417	1	SKID	
15	72315814	2	SCREW	DIN7976-ST4,8X16-F-A3L
16	72315630	1	HEXAGONAL HEAD BOLT	DIN 933 M6X18-8.8A3L
17	72311787	2	DISC	DIN 125-6,4-ST.A3L
18	72313318	1	NUT	DIN6925-M6-8-A3L
19	72373528	4	HOSE CLIP	
20	72395414	1	RUBBER ARCH	
21	72313268	4	NUT	DIN 934 M8-8A3L
22	72315053	6	SPLIT WASHER	FWN 65208-8-A3L
23	72348100	1	AIR FILTER	
			>>23-30	
NOT AVAILABLE IN SINGLE PARTS				
24	72329111	1	DIFFUSER	
25	72329734	1	MICRO-TOP CARTRIDGE	
26	72329735	1	SAFETY CARTRIDGE	
27	72372827	1	NUT	DIN 934 M16X1,5-10A3L
28	72329736	1	FLOOR	
			><29	
29	72326122	1	DUST DISCHARGE VALVE	
30	72329737	1	PIPE CLAMP	
			<-- X458.648.500.000	
31	72392986	1	ABSORPTION INDICATOR	
32	72393687	1	CONNECTING PIPE	
33	72393688	1	BELLOWS	
34	72355730	1	AIR INTAKE	
35	72393690	1	SEALING RING	
36	72330730	1	RAIN CAP	
37	72373806	4	TRUSS HEAD SCREW	DIN 603 M6X16-A3L
38	72311788	4	DISC	DIN 125-8,4-ST.A3L
39	72311787	4	DISC	DIN 125-6,4-ST.A3L
40	72315052	4	SPLIT WASHER	FWN 65208-6-A3L
41	72313266	4	NUT	DIN 934 M6-8A3L
42	72393790	1	THREADED PLATE	
43	72315645	2	HEXAGONAL HEAD BOLT	DIN 933 M8 X 12-8.8A3L
44	72384104	1	CONNECTING PIPE	
47	72377222	2	COVER	DIN 443-40
50	72492958	1	HOSE CLIP	59-83

FARMER 307 (175/00001-00800)
F060727

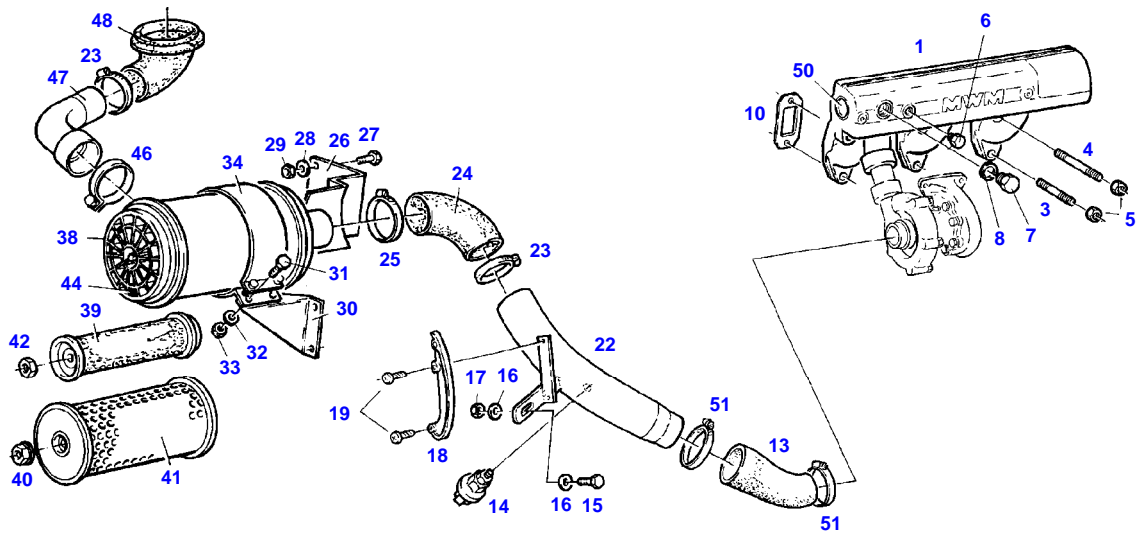

F060727



Item	Part Number	Qty	Description Comments	Technical Specification
PICO				
1	72392836	1	INTAKE MANIFOLD	
3	72374648	3	STUD BOLT	DIN 939 M10X40-10.9
4	72374654	3	STUD BOLT	DIN 939 M10X70-10.9
5	72373015	6	NUT	DIN70615-M10-8-A3B
6	72315433	1	SCREW	DIN 906 M14X1,5-ST
7	72373975	1	SCREW	DIN 910 M20X1,5-ST
8	72376031	1	SEALING WASHER	DIN 7603 A20X24-CU
10	72332145	3	MOLDED SEAL	
12	72311170	1	HOSE CLIP	
13	72392837	1	RUBBER ARCH	
			<>	
	72492958	1	HOSE CLIP	59-83
14	72316876	1	MAINTENANCE SWITCH	
15	72315630	1	HEXAGONAL HEAD BOLT	DIN 933 M6X18-8.8A3L
16	72311787	2	DISC	DIN 125-6,4-ST.A3L
17	72313318	1	NUT	DIN6925-M6-8-A3L
18	72395417	1	SKID	
19	72315814	2	SCREW	DIN7976-ST4,8X16-F-A3L
22	72355442	1	INTAKE MANIFOLD	
	72355443	1	INTAKE MANIFOLD AIR BRAKING SYSTEM	
23	72373528	3	HOSE CLIP	
24	72395421	1	RUBBER ARCH	
25	72311171	1	HOSE CLIP	
26	72356745	1	RETAINER	
27	72315645	3	HEXAGONAL HEAD BOLT	DIN 933 M8 X 12-8.8A3L
28	72315053	3	SPLIT WASHER	FWN 65208-8-A3L
29	72313268	3	NUT	DIN 934 M8-8A3L
30	72395446	1	SUPPORT	
31	72315629	2	HEXAGONAL HEAD BOLT	DIN 933 M6 X 12-8.8A3L
32	72315052	2	SPLIT WASHER	FWN 65208-6-A3L
33	72313266	2	NUT	DIN 934 M6-8A3L
34	72348547	1	PIPE CLAMP	
38	72348545	1	AIR FILTER	
			>>39-42	
39	72332126	1	SAFETY CARTRIDGE	
40	72339030	1	COLLAR NUT	
41	72332441	1	MICRO-TOP CARTRIDGE	
42	72372827	1	NUT	DIN 934 M16X1,5-10A3L
44	72392986	1	ABSORPTION INDICATOR	
46	72373517	1	CLAMPING CLIP	
47	72356718	1	ELBOW FITTING	
48	72393688	1	BELLOWS	
50	72377222	2	COVER	DIN 443-40
51	72492958	1	HOSE CLIP	59-83

FARMER 307 (175/00001-00800)
4270

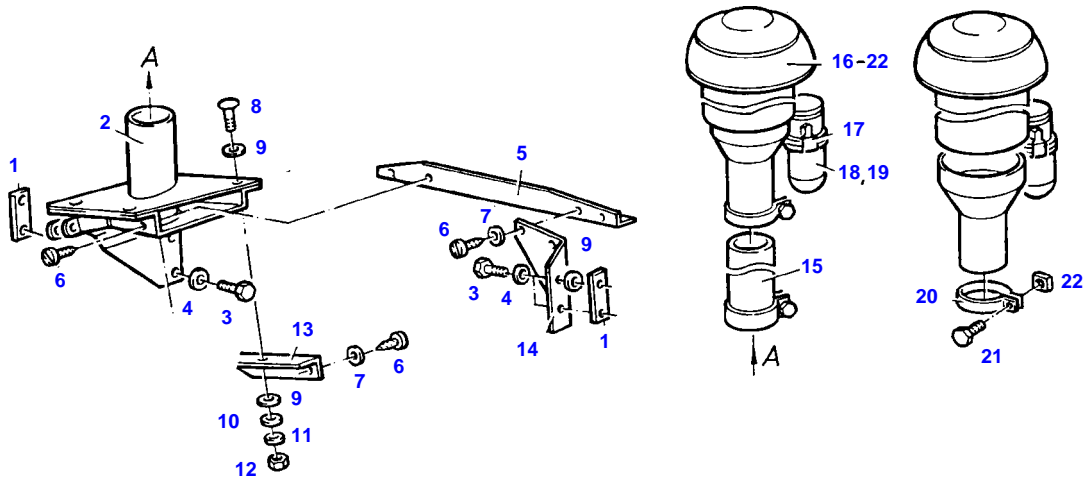

4270

Item	Part Number	Qty	Description Comments	Technical Specification
PICO				
1	72393790	2	THREADED PLATE	
2	72356719	1	AIR INTAKE	
3	72315645	4	HEXAGONAL HEAD BOLT	DIN 933 M8 X 12-8.8A3L
4	72315053	4	SPLIT WASHER	FWN 65208-8-A3L
5	72395424	1	STIFFENING PLATE	
6	72315789	6	SCREW	DIN 7981 ST4,8X9,5-C-H-A3
7	72311785	4	DISC	DIN 125-5,3-ST.A3L
8	72373806	4	TRUSS HEAD SCREW	DIN 603 M6X16-A3L
9	72311788	9	DISC	DIN 125-8,4-ST.A3L
10	72311787	4	DISC	DIN 125-6,4-ST.A3L
11	72315052	4	SPLIT WASHER	FWN 65208-6-A3L
12	72313266	4	NUT	DIN 934 M6-8A3L
13	72395425	1	GUSSET PLATE	
14	72395423	1	GUSSET PLATE	
15	72384104	1	CONNECTING PIPE	
16	72348546	1	CYCLONE AIR CLEANER ><17-22	
17	72321921	1	CATCH	
18	72330736	1	FUNNEL	
19	72320204	1	CONTAINER	
20	72328628	1	PIPE CLAMP	
21	72328615	1	HEXAGONAL HEAD BOLT	
22	72372784	1	SQUARE NUT	DIN 557 M8-5

FARMER 307 (175/00001-00800)
5994

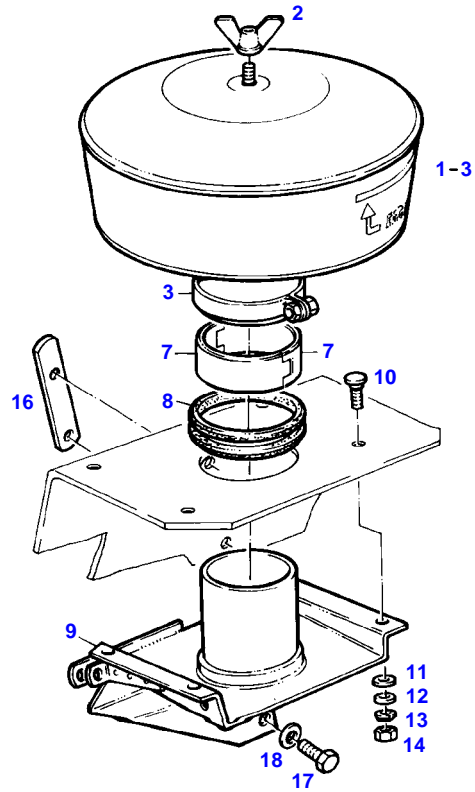

7594

Item	Part Number	Qty	Description Comments	Technical Specification
			PICO	
1	72348552	1	PRE-CLEANER ><1-3	
	72311582	1	DUST CUP	
2	72313238	1	WING NUT	
3	72332464	1	HOSE CLIP	
7	72395448	2	HALF-BEARING	
8	72393690	1	SEALING RING	
9	72356750	1	AIR INTAKE	
10	72373806	4	TRUSS HEAD SCREW	DIN 603 M6X16-A3L
11	72311788	4	DISC	DIN 125-8,4-ST.A3L
12	72311787	4	DISC	DIN 125-6,4-ST.A3L
13	72315052	4	SPLIT WASHER	FWN 65208-6-A3L
14	72313266	4	NUT	DIN 934 M6-8A3L
16	72393790	1	THREADED PLATE	
17	72315645	2	HEXAGONAL HEAD BOLT	DIN 933 M8 X 12-8.8A3L
18	72315053	2	SPLIT WASHER	FWN 65208-8-A3L

FARMER 307 (175/00001-00800)
6338

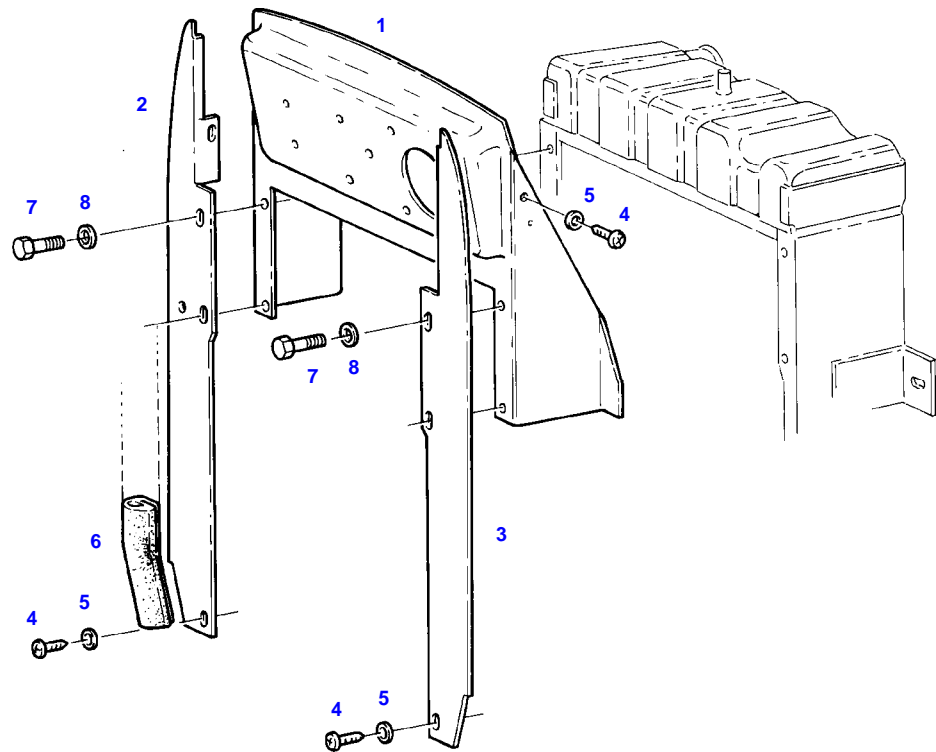

6338

Item	Part Number	Qty	Description Comments	Technical Specification
			RANGE OF TEMPERATURE 1+2 / 1+2 WITH AIR BRAKE SUPPLY EQUIPEMENT	
1	72355533	1	FILTER BRACKET	
2	72393001	1	SPLASH PANEL	
	72393002	1	SPLASH PANEL AIR CONDITION	
3	72392834	1	SPLASH PANEL	
4	72315785	3	SCREW	DIN 7981 ST4,2X9,5-C-H-A3
5	72311817	3	DISC	DIN9021-4,3-140HV-A3L
6	72393692	1	SEALING PROFILE	
7	72315645	4	HEXAGONAL HEAD BOLT	DIN 933 M8 X 12-8.8A3L
8	72317121	4	SPRING WASHER	DIN 137 B8-MECH.VZK

FARMER 307 (175/00001-00800)
6339

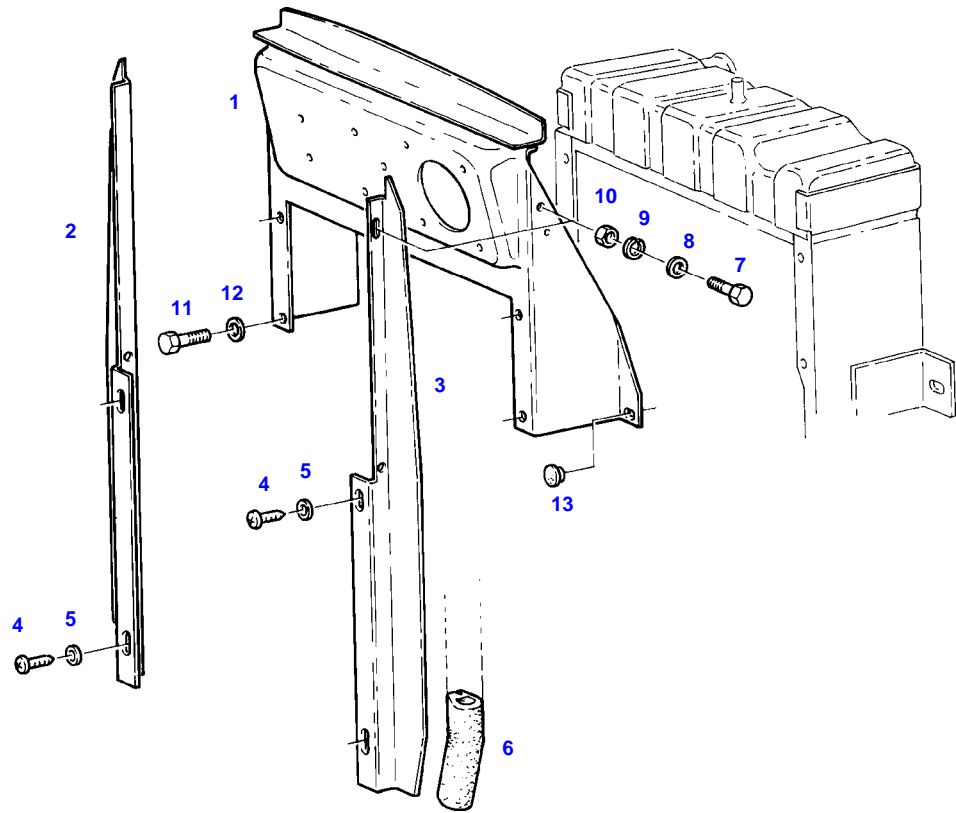

6339

Item	Part Number	Qty	Description Comments	Technical Specification
			RANGE OF TEMPERATURE 1+2 WITH AIR CONDITION	
1	72356752	1	FILTER BRACKET	
2	72392798	1	SPLASH PANEL	
	72392799	1	SPLASH PANEL AIR CONDITION	
3	72392797	1	SPLASH PANEL	
4	72315785	4	SCREW	DIN 7981 ST4,2X9,5-C-H-A3
5	72311817	4	DISC	DIN9021-4,3-140HV-A3L
6	72393692	1	SEALING PROFILE	
7	72315629	2	HEXAGONAL HEAD BOLT	DIN 933 M6 X 12-8.8A3L
8	72311787	2	DISC	DIN 125-6,4-ST.A3L
9	72315052	2	SPLIT WASHER	FWN 65208-6-A3L
10	72313266	2	NUT	DIN 934 M6-8A3L
11	72315645	4	HEXAGONAL HEAD BOLT	DIN 933 M8 X 12-8.8A3L
12	72317121	4	SPRING WASHER	DIN 137 B8-MECH.VZK
13	72314765	1	LOCKING PLUG	

FARMER 307 (175/00001-00800)
4115

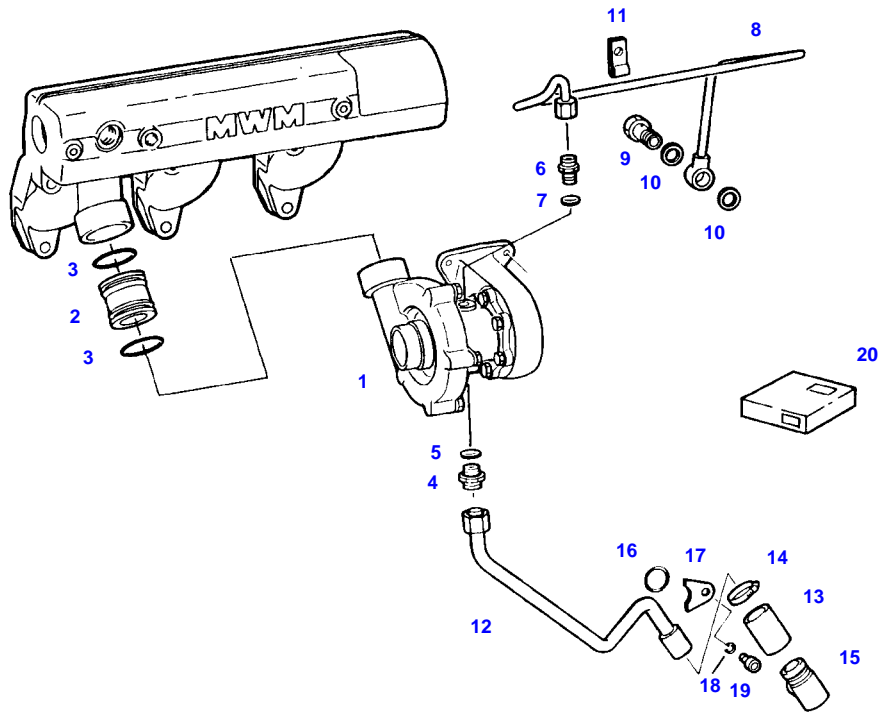

4115

Item	Part Number	Qty	Description Comments	Technical Specification
1	72329531	1	TURBOCHARGER ><20	
2	72329534	1	CONNECTING PIECE	
3	72376526	2	O-RING	35X4
4	72377894	1	SCREW NECK	
5	72376066	1	SEALING WASHER	DIN 7603 D16X20-CU
6	72377895	1	SCREW NECK	DIN 3901-L8A-M-ST-A3L
7	72376065	1	SEALING WASHER	DIN 7603 D12X16-CU
8	72329535	1	LUBE OIL LINE	
9	72374956	1	BANJO BOLT	DIN7623/3.70-A10-6.8
10	72315098	2	SEALING WASHER	DIN 7603 A16X22-CU
11	72329536	1	PIPE CLAMP	
12	72329537	1	LUBE OIL LINE	
13	72332160	1	HOSE PIECE	
14	72311167	2	HOSE CLIP	
15	72343888	1	MANIFOLD	
16	72343889	1	SEAL	
17	72343890	1	RETAINING SHEET METAL	
18	72315053	1	SPLIT WASHER	FWN 65208-8-A3L
19	72315489	1	SOCKET HEAD BOLT	DIN 912-M8 X 16-8.8-A3L
20	72329532	1	SPARE PARTS KIT TURBO CHARGER	
	72329533	1	ROTOR ASSEMBLY SET TURBO CHARGER	

FARMER 307 (175/00001-00800)
6341

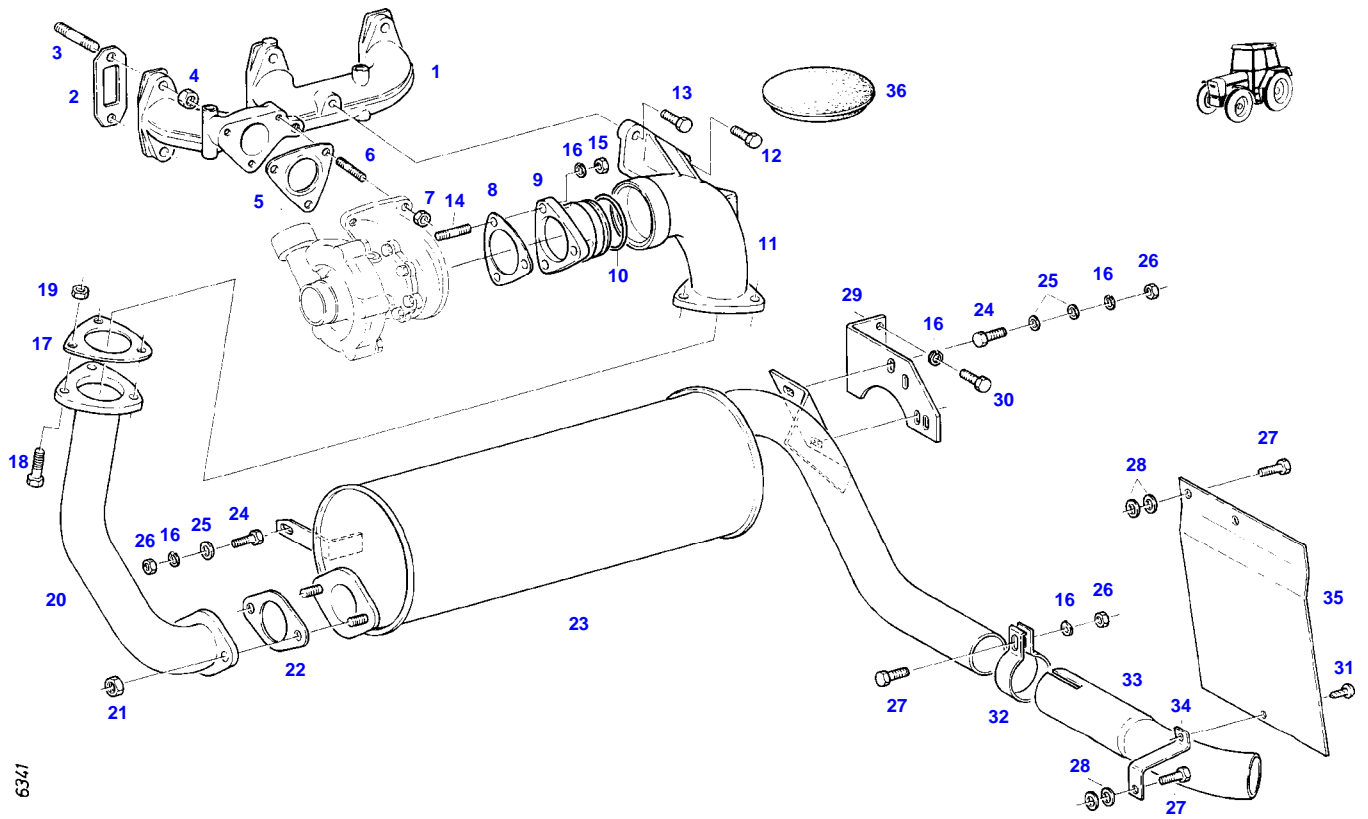

Item	Part Number	Qty	Description Comments	Technical Specification
1	72392839	1	EXHAUST PIPE	
2	72332145	3	MOLDED SEAL	
3	72374648	6	STUD BOLT	DIN 939 M10X40-10.9
4	72373015	6	NUT	DIN70615-M10-8-A3B
5	72329538	1	MOLDED SEAL	
6	72313770	3	STUD BOLT	FWN64891-M8X20-8.8
7	72372805	3	NUT	DIN 934 M8-10 C2A
8	72392991	1	SEAL	
9	72392990	1	FLANGE	
10	72332980	1	LAMELLAR RING	
11	72392989	1	MANIFOLD	
12	72374440	1	HEXAGONAL HEAD BOLT	DIN 933 M10X22-8.8
13	72315681	1	HEXAGONAL HEAD BOLT	DIN 933 M10X25-8.8A3L
14	72313770	3	STUD BOLT	FWN64891-M8X20-8.8
15	72313269	3	NUT	DIN 934 M8-8C2A
16	72315053	9	SPLIT WASHER	FWN 65208-8-A3L
17	72407298	1	MOLDED SEAL	
18	72315657	3	HEXAGONAL HEAD BOLT	DIN 933 M8 X 30-8.8A3L
19	72313269	3	NUT	DIN 934 M8-8C2A
20	72355522	1	EXHAUST PIPE	
	72355530	1	EXHAUST PIPE ENGINE BRAKE	
21	72313273	2	NUT	DIN 934 M10-MS
22	72376173	1	SEAL	DIN71511-56X82X1,5-ST AFM5M.E.
23	72355444	1	EXHAUST MUFFLER	
24	72315646	3	HEXAGONAL HEAD BOLT	DIN 933 M8X18-8.8A3L
25	72311788	6	DISC	DIN 125-8,4-ST.A3L
26	72313268	4	NUT	DIN 934 M8-8A3L
27	72315657	4	HEXAGONAL HEAD BOLT	DIN 933 M8 X 30-8.8A3L
28	72311824	6	DISC	DIN9021-8,4-140HV-A3L
29	72396312	1	RETAINING BRACKET	
30	72315642	2	HEXAGONAL HEAD BOLT	DIN 933 M8 X 16-8.8A3L
31	72315820	1	SCREW	DIN7976-ST6,3X13-C-A3L
32	72373437	1	PIPE CLAMP	DIN71555-63,5 EDELSTAHL
33	72393695	1	EXHAUST TAILPIPE	
34	72393697	1	RETAINER	
35	72395464	1	DEFLECTOR	
36	72395945	1	COVER	

FARMER 307 (175/00001-00800)
7730

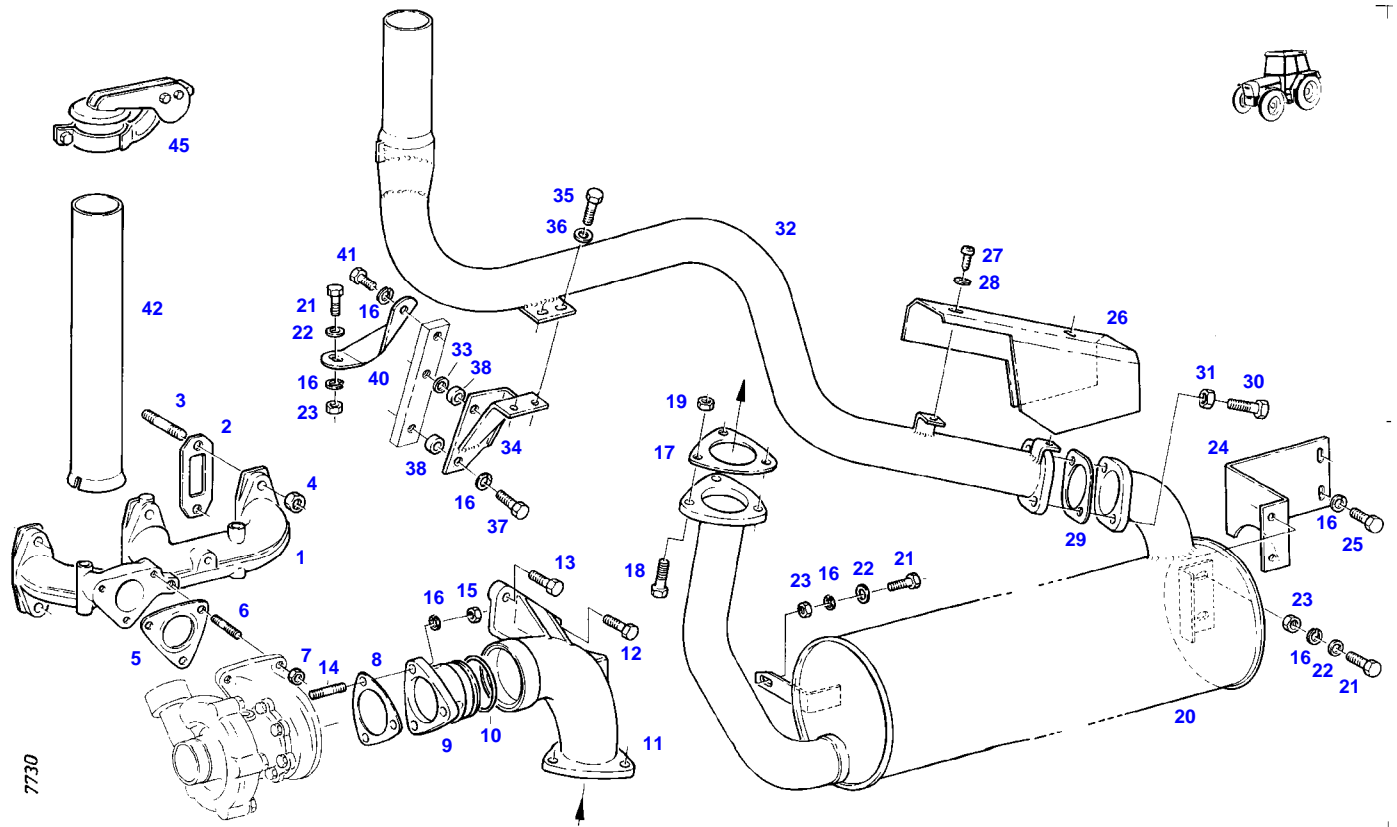

Item	Part Number	Qty	Description Comments	Technical Specification
1	72392839	1	EXHAUST PIPE	
2	72332145	3	MOLDED SEAL	
3	72374648	6	STUD BOLT	DIN 939 M10X40-10.9
4	72373015	6	NUT	DIN70615-M10-8-A3B
5	72329538	1	MOLDED SEAL	
6	72313770	3	STUD BOLT	FWN64891-M8X20-8.8
7	72372805	3	NUT	DIN 934 M8-10 C2A
8	72392991	1	SEAL	
9	72392990	1	FLANGE	
10	72332980	1	LAMELLAR RING	
11	72392989	1	MANIFOLD	
12	72374440	1	HEXAGONAL HEAD BOLT	DIN 933 M10X22-8.8
13	72315681	1	HEXAGONAL HEAD BOLT	DIN 933 M10X25-8.8A3L
14	72313770	3	STUD BOLT	FWN64891-M8X20-8.8
15	72313269	3	NUT	DIN 934 M8-8C2A
16	72315053	12	SPLIT WASHER	FWN 65208-8-A3L
17	72407298	1	MOLDED SEAL	
18	72315657	3	HEXAGONAL HEAD BOLT	DIN 933 M8 X 30-8.8A3L
19	72313269	3	NUT	DIN 934 M8-8C2A
20	72355532	1	EXHAUST MUFFLER	
			<>	
	72407298	2	MOLDED SEAL	
	72393009	1	INTERMEDIATE PIECE	
	72315539	3	HEXAGONAL HEAD BOLT	DIN 931 M8X80-8.8 A3L
	72355532	1	EXHAUST MUFFLER	
			ENGINE BRAKE	
21	72315646	4	HEXAGONAL HEAD BOLT	DIN 933 M8X18-8.8A3L
22	72311788	8	DISC	DIN 125-8,4-ST.A3L
23	72313268	4	NUT	DIN 934 M8-8A3L
24	72392992	1	RETAINING BRACKET	
25	72315642	2	HEXAGONAL HEAD BOLT	DIN 933 M8 X 16-8.8A3L
26	72392994	1	SHROUD PANEL	
27	72315820	2	SCREW	DIN7976-ST6,3X13-C-A3L
28	72311822	2	DISC	DIN9021-6,4-140HV-A3L
29	72376173	1	SEAL	DIN71511-56X82X1,5-ST AFM5M.E.
30	72315685	2	HEXAGONAL HEAD BOLT	DIN 933 M10X30-8.8A3L
31	72313273	2	NUT	DIN 934 M10-MS
32	72355523	1	EXHAUST PIPE	
33	72311809	2	DISC	DIN 440-R9-ST-A3L
34	72355526	1	RETAINER	
35	72315650	2	HEXAGONAL HEAD BOLT	DIN 933 M8 X 20-8.8A3L
36	72311824	2	DISC	DIN9021-8,4-140HV-A3L
37	72315657	2	HEXAGONAL HEAD BOLT	DIN 933 M8 X 30-8.8A3L
38	72400319	2	DISC	
40	72392840	1	ANGLE	
41	72315645	1	HEXAGONAL HEAD BOLT	DIN 933 M8 X 12-8.8A3L
42	72355528	1	END PIPE	
			<>	
	72348670	1	EXTENSION TUBE	
45	72348233	1	EXHAUST WEATHER CAP	

FARMER 307 (175/00001-00800)
6344

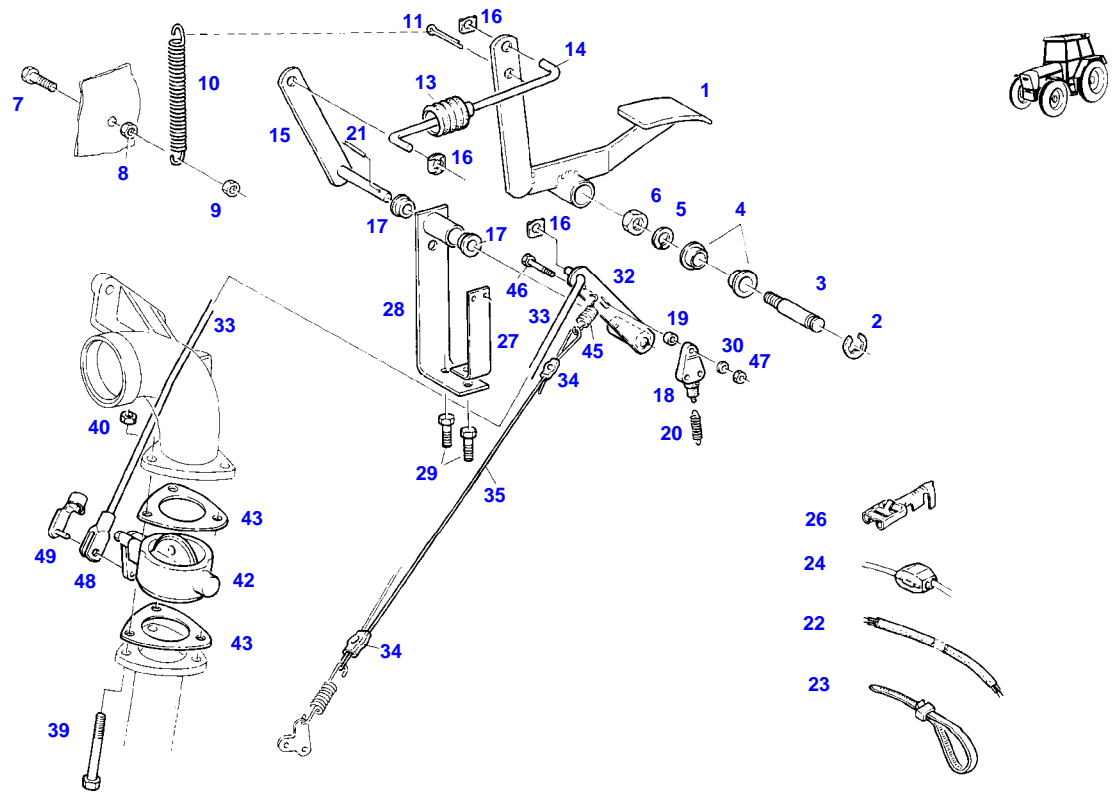

6344

Item	Part Number	Qty	Description Comments	Technical Specification
1	72356732	1	FOOT LEVER	
2	72317146	1	LOCK WASHER	DIN6799-12-A3L
3	72394196	1	CARRIER	
4	72310596	2	BUSH	
5	72315054	1	SPLIT WASHER	FWN 65208-10-A3L
6	72313272	1	NUT	DIN 934 M10-8A3L
7	72315630	1	HEXAGONAL HEAD BOLT	DIN 933 M6X18-8.8A3L
8	72313266	1	NUT	DIN 934 M6-8A3L
9	72313318	1	NUT	DIN6925-M6-8-A3L
10	72394186	1	PULLING SPRING	
11	72313879	1	COTTER	DIN 94-5X20-ST.A3L
13	72377280	1	BELLOWS	
14	72395433	1	ROD	
15	72356730	1	LEVER	
16	72311180	3	DUO-CLIP	8 SXN10
17	72393653	2	BUSH	
18	72380934	1	STOP LIGHT SWITCH	
19	72310699	1	BUSH	
20	72380433	1	PULLING SPRING	
21	72375133	1	TENSIONING PIN	ISO8752-4X24-A-ST-OB3
22			NO LONGER AVAILABLE	
23	72316916	3	CABLE STRAP	FWN 66650 B175X4-SW
24	72379227	1	CABLE CONNECTOR	
26	72314785	1	PLUG IN SLEEVE	
27	72395435	1	ANGLE	
28	72356731	1	CARRIER	
29	72315657	2	HEXAGONAL HEAD BOLT	DIN 933 M8 X 30-8.8A3L
30	72311817	3	DISC	DIN9021-4,3-140HV-A3L
32	72355458	1	LEVER	
33	72392998	1	ROD	
34	72333529	2	CABLE CLAMP	
35	72450805	1	ROPE 1X 450 MM CUT TO LENGTH	L=1000 DIN 3055-2-FE-ZNK 15
39	72315539	3	HEXAGONAL HEAD BOLT	DIN 931 M8X80-8.8 A3L
40	72313269	3	NUT	DIN 934 M8-8C2A
42	72348235	1	ENGINE BRAKE	
43	72407298	2	MOLDED SEAL	
45	72316492	1	PULLING SPRING	
46	72315617	1	HEXAGONAL HEAD BOLT	DIN 933 M4X30-8.8A3L
47	72313263	1	NUT	DIN 934 M4-8A3L
48	72311309	1	CLEVIS	DIN 71752 G8X32-A3L
49	72372473	1	BOLT	FWN 64072 8X32 A3L

FARMER 307 (175/00001-00800)
4126

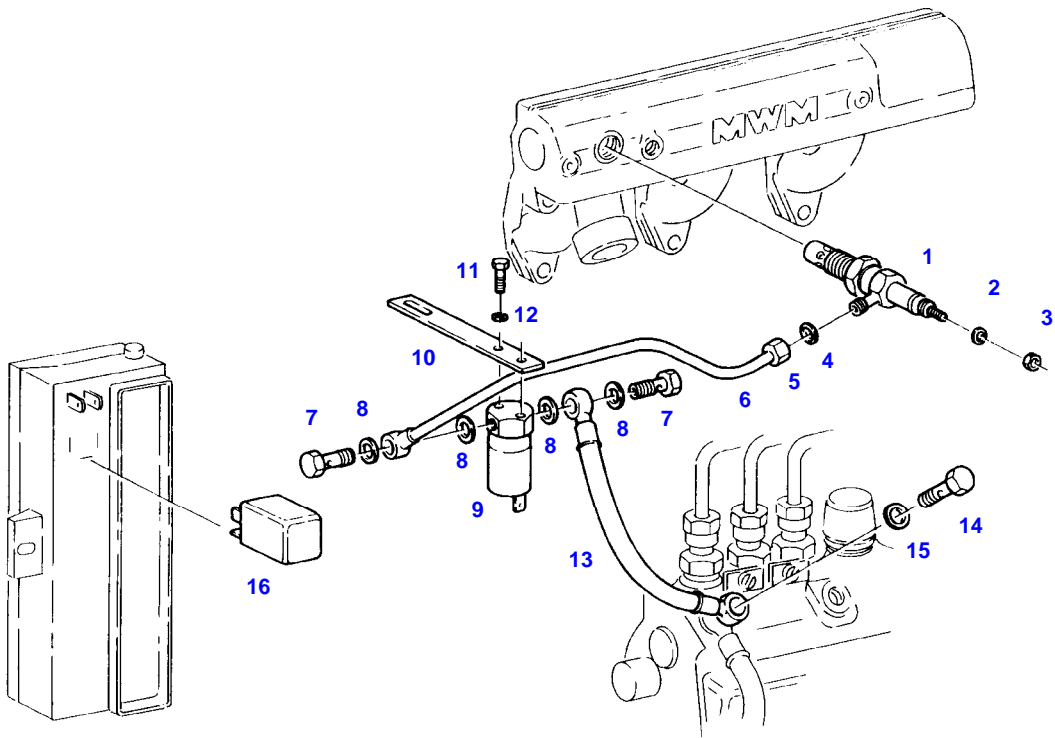

4126

Item	Part Number	Qty	Description Comments	Technical Specification
1	72495170	1	ROD FLAME GLOW PLUG	
2	72317119	1	SPRING WASHER	DIN 137 B5-MECH.VZK
3	72313264	1	NUT	DIN 934 M5-8A3L
4	72377312	1	DOUBLE V-RING	DIN 3862-6-9SMNPB28K+G
5	72378005	1	CONNECTING NUT	DIN 3870 ALL6-9S20K A3L
6	72355460	1	TUBING	
7	72315806	2	BANJO BOLT	DIN 7643-6-3-A3L
8	72315088	4	SEALING WASHER	DIN 7603 A10X13,5-CU
9	72317090	1	VALVE SOLENOID	
10	72316724	1	RETAINER	
11	72315629	2	HEXAGONAL HEAD BOLT	DIN 933 M6 X 12-8.8A3L
12	72315052	2	SPLIT WASHER	FWN 65208-6-A3L
13	72356736	1	LINE	
14	72310187	1	DOUBLE BOLT	
15	72315094	1	SEALING WASHER	DIN 7603 A14X18-CU
16	72428226	1	GLOW TIME RELAY	

FARMER 307 (175/00001-00800)
4574

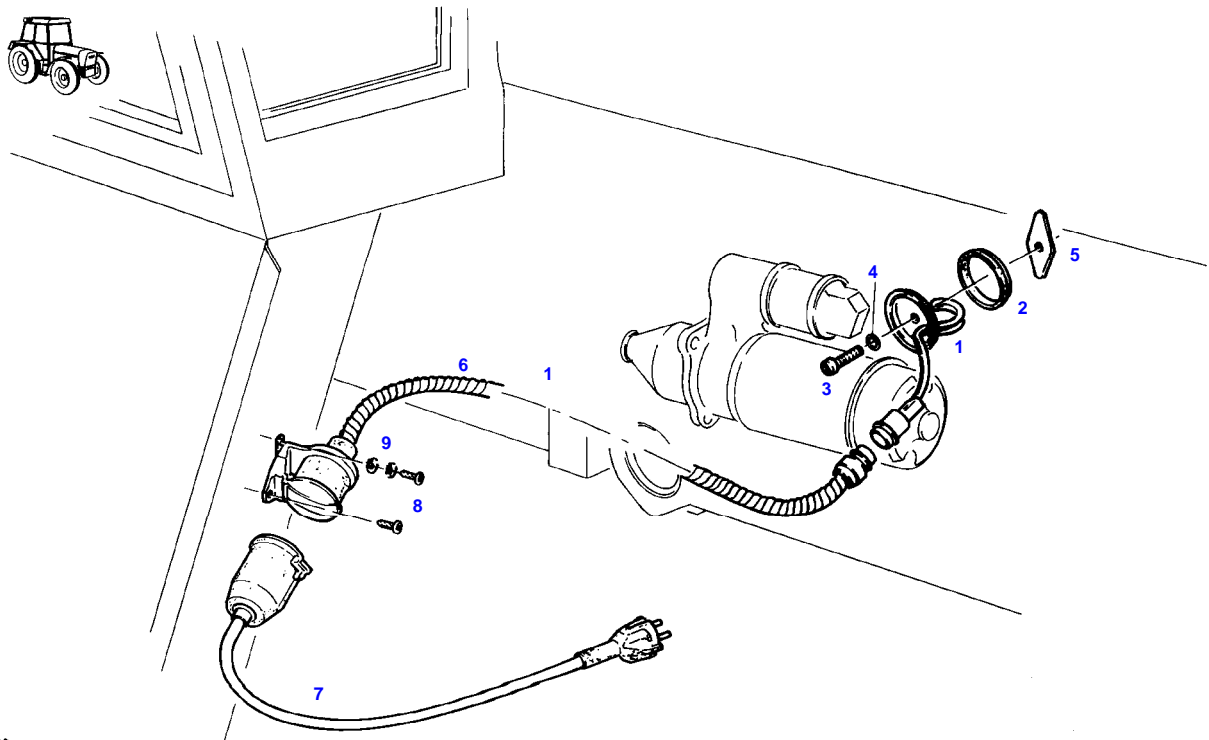

4574

Item	Part Number	Qty	Description Comments	Technical Specification
1	72385222	1	ENGINE PRE-HEATER ><1-9 <-- 0098.071.100	
	72365565	1	HEATER ELEMENT	
2	72332589	1	SEAL	
3	72332590	1	SCREW <>	
	72332592	1	O-RING	
	72315466	1	SOCKET HEAD BOLT <>	DIN 912 M6X30-8.8
	72311787	1	DISC	DIN 125-6,4-ST.A3L
	72376379	1	O-RING	5,3X2,4-FPM 80 FWN56402
	72311787	1	DISC	DIN 125-6,4-ST.A3L
4	72332592	1	O-RING	
	72376379	1	O-RING	5,3X2,4-FPM 80 FWN56402
5	72332591	1	COULTER CLAMP	
6	72310873	1	CABLE <-- H816.200.250.210 1X <>	
	72315615	2	HEXAGONAL HEAD BOLT	DIN 933 M4X16-8.8A3L
	72494152	1	POWER CABLE	
	72424447	1	MOUTING BRACKET	
7	72317178	1	POWER CABLE	
8	72315786	3	SCREW	DIN 7981 ST4,2X13-C-H-A3L
	72315408	3	FLAT HEAD CAPSCREW	DIN 85 M4X12-4.8A3L
9	72317126	4	SERRATED LOCK WASHER	DIN 6798 A5,3
	72313263	3	NUT	DIN 934 M4-8A3L
	72315050	3	SPLIT WASHER	FWN 65208-4-A3L
	72316916	4	CABLE STRAP NOT ILLUSTRATED	FWN 66650 B175X4-SW
	72317193	1	SECURING CLIP NOT ILLUSTRATED	



Suggest:

For more complete manuals. Please go to the home page.

<https://www.ebooklibonline.com>

If the above button click is invalid. Please download this document first, and then click the above link to download the complete manual.

Thank you so much for reading

FARMER 307 (175/00001-00800)
40385

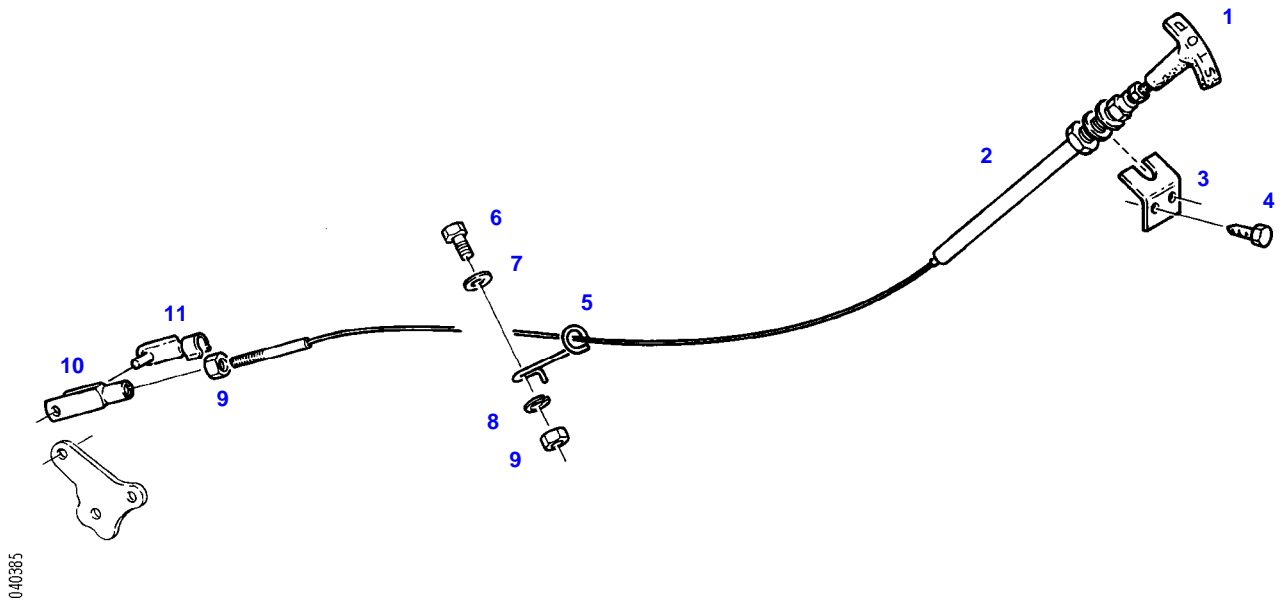

040385

Item	Part Number	Qty	Description Comments	Technical Specification
1	72329543	1	HANDLE	
2	72348665	1	STOP CABLE	
			><1	
			<>	
	72313264	1	NUT	DIN 934 M5-8A3L
	72396326	1	THREADED SOCKET	
	72355461	1	CONTROL CABLE	
3	72392845	1	RETAINER	
4	72315820	2	SCREW	DIN7976-ST6,3X13-C-A3L
5	72393651	1	REVERSING BOW	
6	72315626	1	HEXAGONAL HEAD BOLT	DIN 933-M6 X 16-8.8-A3L
7	72311822	1	DISC	DIN9021-6,4-140HV-A3L
8	72315052	1	SPLIT WASHER	FWN 65208-6-A3L
9	72313266	2	NUT	DIN 934 M6-8A3L
10	72311308	1	CLEVIS	DIN 71752 G6X24-A3L
11	72310448	1	BOLT	FWN 64072 6X24 A3L
	72392846	1	SLEEVE	
			FOR ENGLAND	
			NOT ILLUSTRATED	

FARMER 307 (175/00001-00800)
5402

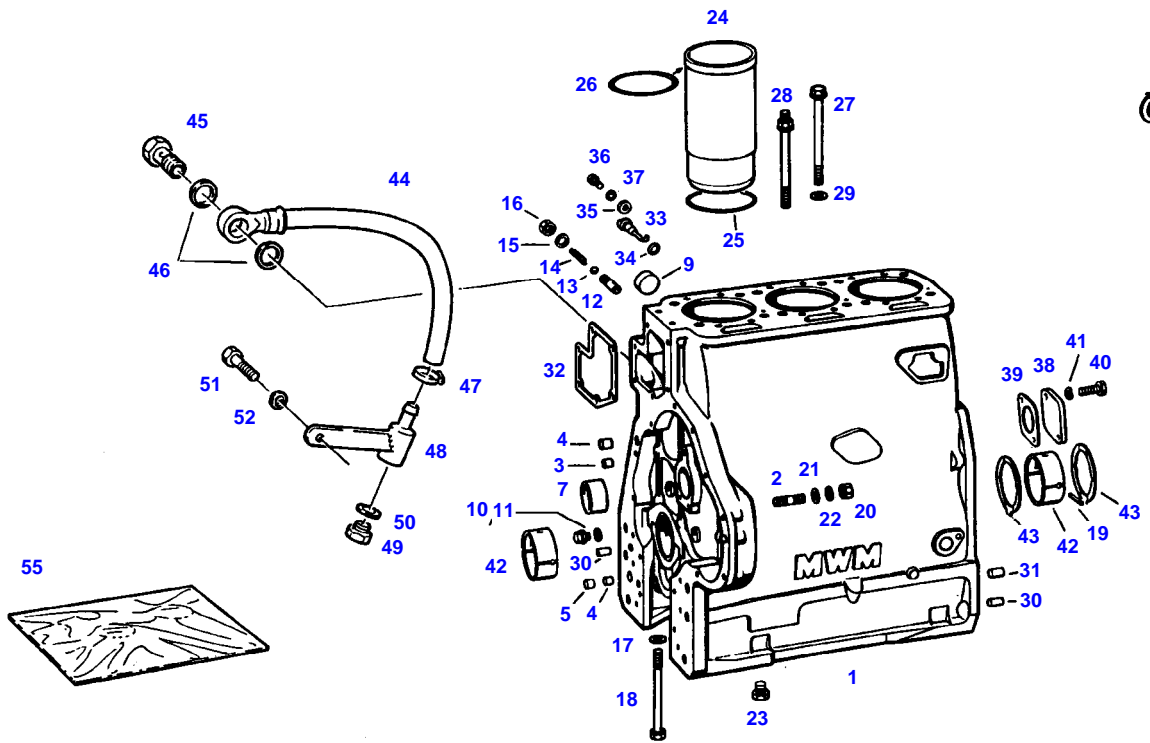

5402

<https://www.ebooklibonline.com>

Hello dear friend!

Thank you very much for reading.

Enter the link into your browser.

The full manual is available for immediate download.

<https://www.ebooklibonline.com>