

**TABLE OF CONTENT**

<b>Page Number</b>	<b>Page Title</b>	<b>Page Reference</b>
01-000-TOC	ENGINE, FUEL AND EXHAUST SYSTEM	01-000-TOC
02-000-TOC	AXLES	02-000-TOC
03-000-TOC	STEERING SYSTEM	03-000-TOC
04-000-TOC	DRIVE TRAIN SYSTEM	04-000-TOC
05-000-TOC	COMPRESSED AIR SYSTEM	05-000-TOC
06-000-TOC	HYDRAULIC SYSTEM	06-000-TOC
07-000-TOC	ELECTRICAL SYSTEM	07-000-TOC
08-000-TOC	CAB	08-000-TOC
09-000-TOC	AIR CONDITIONING AND HEATING SYSTEM	09-000-TOC
10-000-TOC	CHASSIS	10-000-TOC
11-000-TOC	WHEELS	11-000-TOC
12-000-TOC	IMPLEMENT LIFT SYSTEM FRONT	12-000-TOC
13-000-TOC	IMPLEMENT LIFT SYSTEM REAR	13-000-TOC
14-000-TOC	FRONT/REAR LOADERS	14-000-TOC
15-000-TOC	ATTACHMENTS	15-000-TOC
16-000-TOC	ACCESSORIES	16-000-TOC



Item	Part Number	Qty	Description Comments	Technical Specification
			RANGE OF TEMPERATURE 1+1 WITH AIR BRAKE SUPPLY EQUIPEMENT RANGE OF TEMPERATURE 2+2 WITH AIR BRAKE SUPPLY EQUIPEMENT RANGE OF TEMPERATURE 1+2 WITH AIR CONDITION <-- 162/6146	
1	72348099	1	RADIATOR ><1-3	
2	72478248	1	COLLER LOCKING	
3	72436028	1	HOSE	L=1500FWN65912-10X2-PVC-W-G
4			NOT USED	
6			NO SPARE PART	
10	72393668	1	FAN COVER	
11	72315818	4	SCREW	DIN7976-ST4,2X25-C-A3L
	72315787	2	SCREW	DIN 7981 B4,2X16-A3L
12	72311817	6	DISC	DIN9021-4,3-140HV-A3L
13	72379109	2	MARKING PLATE	FWN66556-35X68-SCHUTZVORR.N.OE
14	72315660	1	HEXAGONAL HEAD BOLT	DIN 933 M8X35-8.8A3L
15	72311888	2	DISC	
16	72310718	2	BUSH	
17	72312479	4	UNIVERSAL SPOUT	
18	72311788	3	DISC	DIN 125-8,4-ST.A3L
19	72311788	1	DISC	DIN 125-8,4-ST.A3L
20	72315053	6	SPLIT WASHER	FWN 65208-8-A3L
21	72315650	4	HEXAGONAL HEAD BOLT	DIN 933 M8 X 20-8.8A3L
22	72313268	5	NUT	DIN 934 M8-8A3L
23	72393671	2	BRACE	
24	72378063	1	RELIEF VALVE	DIN71401-CM14X1,5KEG
25	72438345	1	HOSE CLIP	
26	72389310	1	HOSE	

**<https://www.ebooklibonline.com>**

Hello dear friend!

Thank you very much for reading.

Enter the link into your browser.

The full manual is available for immediate download.

**<https://www.ebooklibonline.com>**

FARMER 305 (162/00001-07500)  
4261

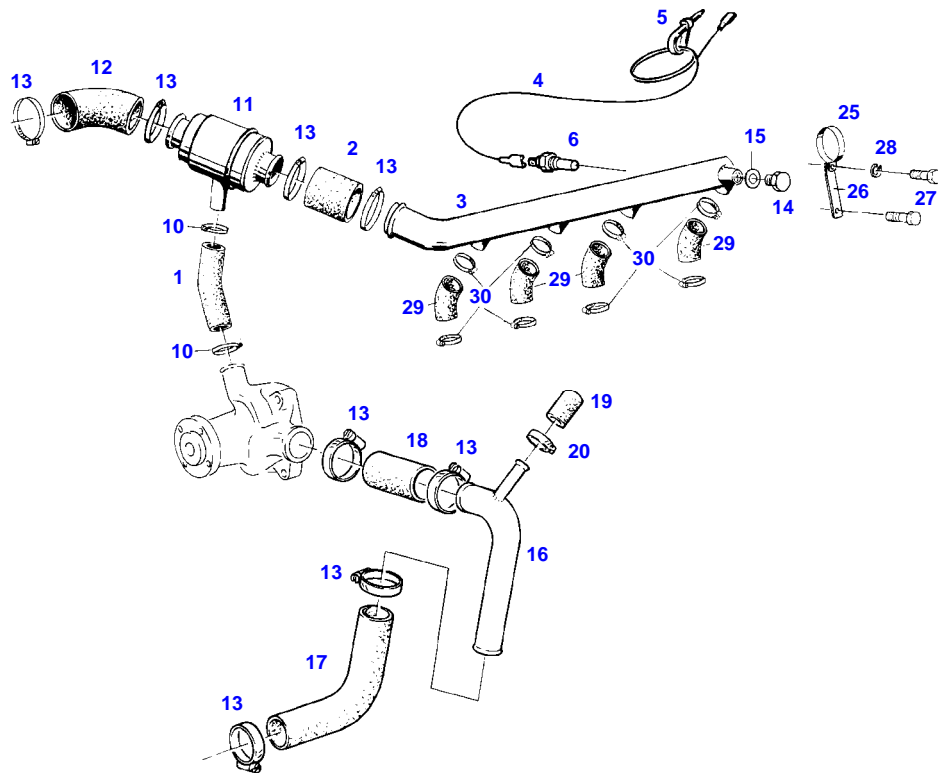

4261

Item	Part Number	Qty	Description Comments	Technical Specification
			<b>RANGE OF TEMPERATURE 1+1 WITH AIR BRAKE SUPPLY EQUIPEMENT &lt;-- 162/6146</b>	
1	72393670	1	RUBBER ARCH	
2	72450416	1	HOSE 1X 45MM CUT TO LENGTH	L=120 DIN73411-35X
3	72329110	1	COOLING WATER SUPPLY LINE	
4			NOT USED	
5			NOT USED	
6			SEE LIGHTS AND HORN	
10	72311167	2	HOSE CLIP	
11	72380193	1	THERMOSTAT	75GR+-2GR
12	72393666	1	RUBBER ARCH	
13	72311162	8	HOSE CLIP	
14	72315802	1	SCREW	DIN 7604 AM22X1,5-ST
15	72315101	1	SEALING WASHER	DIN 7603 A22X27-CU
16	72356702	1	SUCTION LINE	
17	72395412	1	RUBBER ARCH	
18	72393672	1	REDUCER	
19	72404925	1	CAP	
20	72311167	1	HOSE CLIP	
25	72337051	2	PIPE CLAMP	
26	72332467	2	PLATE LINK	
27	72315630	2	HEXAGONAL HEAD BOLT	DIN 933 M6X18-8.8A3L
28	72315052	2	SPLIT WASHER	FWN 65208-6-A3L
29	72329731	4	RUBBER ARCH	
30	72311167	8	HOSE CLIP	

FARMER 305 (162/00001-07500)  
4261

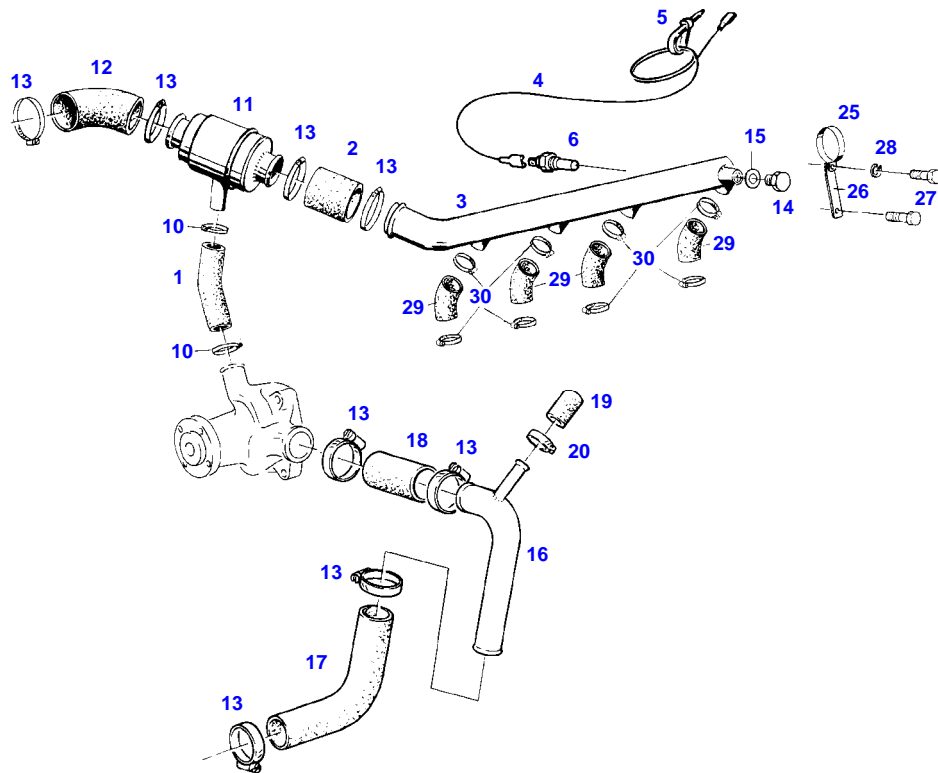

4261

Item	Part Number	Qty	Description Comments	Technical Specification
			RANGE OF TEMPERATURE 2+2 WITH AIR BRAKE SUPPLY EQUIPEMENT RANGE OF TEMPERATURE 1+2 WITH AIR CONDITION <-- 162/6146	
1	72392140	1	RUBBER ARCH	
2	72436027	1	HOSE 1X 120MM	L=320 DIN73411-25X3,5 R
3	72332460	1	COOLING WATER SUPPLY LINE	
4	72356040	1	RESISTOR CABLE	
5	72316916	1	CABLE STRAP	FWN 66650 B175X4-SW
6				
			SEE LIGHTS AND HORN	
10	72311167	2	HOSE CLIP	
11	72380193	1	THERMOSTAT	75GR+-2GR
12	72393666	1	RUBBER ARCH	
13	72311162	8	HOSE CLIP	
14	72315802	1	SCREW	DIN 7604 AM22X1,5-ST
15	72315101	1	SEALING WASHER	DIN 7603 A22X27-CU
16	72356702	1	SUCTION LINE	
17	72395412	1	RUBBER ARCH	
18	72393672	1	REDUCER	
19	72404925	1	CAP	
20	72311167	1	HOSE CLIP	
25	72337051	2	PIPE CLAMP	
26	72332467	2	PLATE LINK	
27	72315630	2	HEXAGONAL HEAD BOLT	DIN 933 M6X18-8.8A3L
28	72315052	2	SPLIT WASHER	FWN 65208-6-A3L
29	72329731	4	RUBBER ARCH	
30	72311167	8	HOSE CLIP	

FARMER 305 (162/00001-07500)  
4267

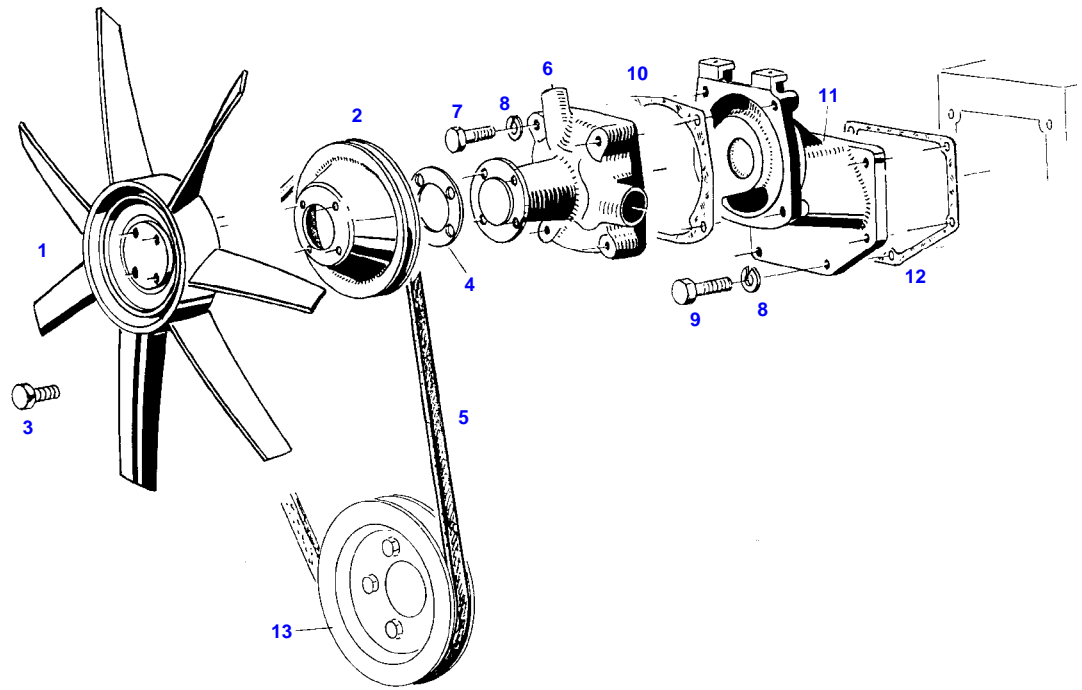

4267

Item	Part Number	Qty	Description Comments	Technical Specification
<b>RANGE OF TEMPERATURE 1</b>				
1	72331298	1	FAN	
2	72327206	1	V BELT SHEAVE	
3	72375063	4	LOCK SCREW	FWN 64993 M8X22-12.9
4	72394835	1	DISC	
5				
6	72340133	1	SEE ALTERNATOR ASSY CENTRIFUGAL PUMP --> 162/6308	
	72343555	1	CENTRIFUGAL PUMP <-- 162/6309	
	72340135	1	REPAIR KIT --> 162/6308 <-- F281.200.610.010	
	72343940	1	REPAIR KIT <-- 162/6309	
7	72315659	4	HEXAGONAL HEAD BOLT	DIN 933 M8X35-8.8
8	72315053	10	SPLIT WASHER	FWN 65208-8-A3L
9	72315654	6	HEXAGONAL HEAD BOLT	DIN 933 M8X28-8.8A3L
10	72328678	1	SEAL	
11	72330788	1	INTERMEDIATE PIECE <-- F162.204.610.010	
12				
			SEE CRANKCASE	
13				
			SEE CRANKSHAFT	

FARMER 305 (162/00001-07500)  
4267

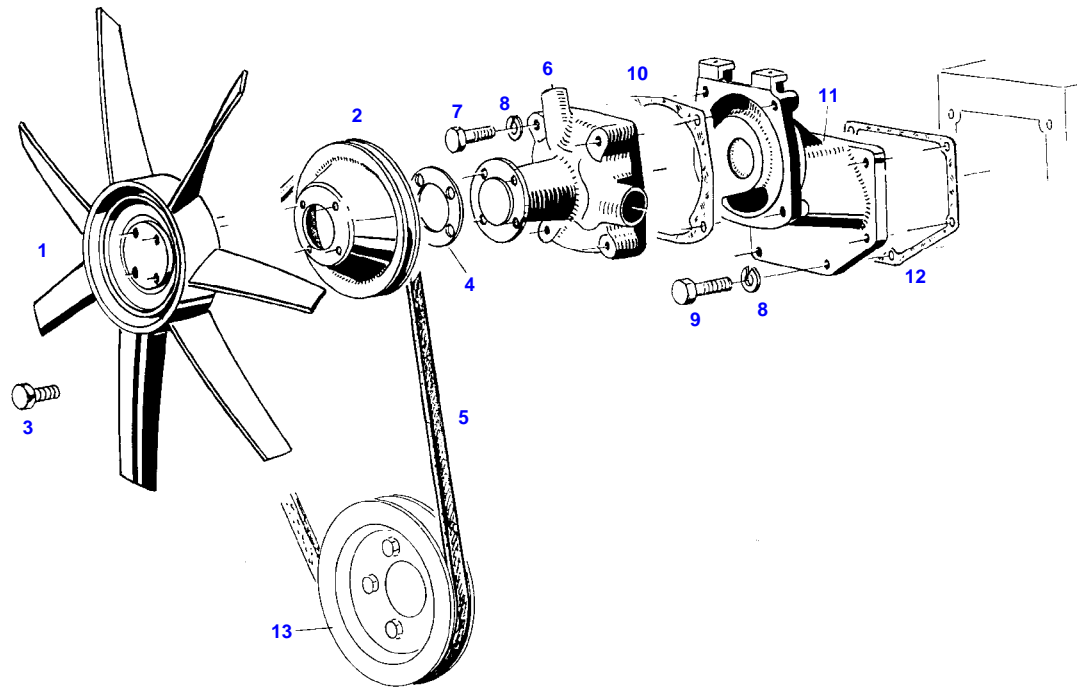

4267

Item	Part Number	Qty	Description Comments	Technical Specification
<b>RANGE OF TEMPERATURE 2</b>				
1	72380200	1	FAN	455/7
2	72399923	1	V BELT SHEAVE	
3	72375067	4	LOCK SCREW	FWN 64993 M8X35-90
4				
5			NOT USED	
6	72340133	1	SEE ALTERNATOR ASSY CENTRIFUGAL PUMP --> 162/6308	
	72343555	1	CENTRIFUGAL PUMP <-- 162/6309	
	72340135	1	REPAIR KIT --> 162/6308 <-- F281.200.610.010	
	72343940	1	REPAIR KIT <-- 162/6309	
7	72315659	4	HEXAGONAL HEAD BOLT	DIN 933 M8X35-8.8
8	72315053	10	SPLIT WASHER	FWN 65208-8-A3L
9	72315654	6	HEXAGONAL HEAD BOLT	DIN 933 M8X28-8.8A3L
10	72328678	1	SEAL	
11	72330788	1	INTERMEDIATE PIECE <-- F162.204.610.010	
12			SEE CRANKCASE	
13			SEE CRANKSHAFT	

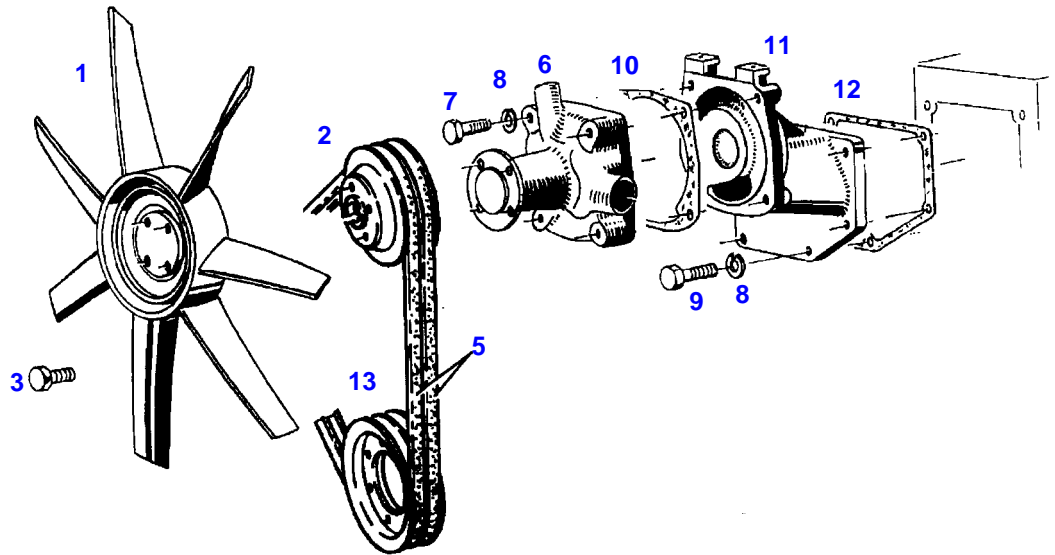

01160

Item	Part Number	Qty	Description Comments	Technical Specification
<b>AIR BRAKIN SYSTEM</b>				
1	72331298	1	FAN	
2	72393674	1	V BELT SHEAVE	
3	72375066	4	LOCK SCREW	FWN 64993-M8X30-90
5			SEE COMPRESSOR INSTALLAT	
6	72340133	1	CENTRIFUGAL PUMP --> 162/6308	
	72343555	1	CENTRIFUGAL PUMP <-- 162/6309	
	72340135	1	REPAIR KIT --> 162/6308 <-- F281.200.610.010	
	72343940	1	REPAIR KIT <-- 162/6309	
7	72315659	4	HEXAGONAL HEAD BOLT	DIN 933 M8X35-8.8
8	72315053	10	SPLIT WASHER	FWN 65208-8-A3L
9	72315654	6	HEXAGONAL HEAD BOLT	DIN 933 M8X28-8.8A3L
10	72328678	1	SEAL	
11	72330788	1	INTERMEDIATE PIECE <-- F162.204.610.010	
12			SEE CRANKCASE	
13			SEE COMPRESSOR INSTALLAT	

FARMER 305 (162/00001-07500)  
11170

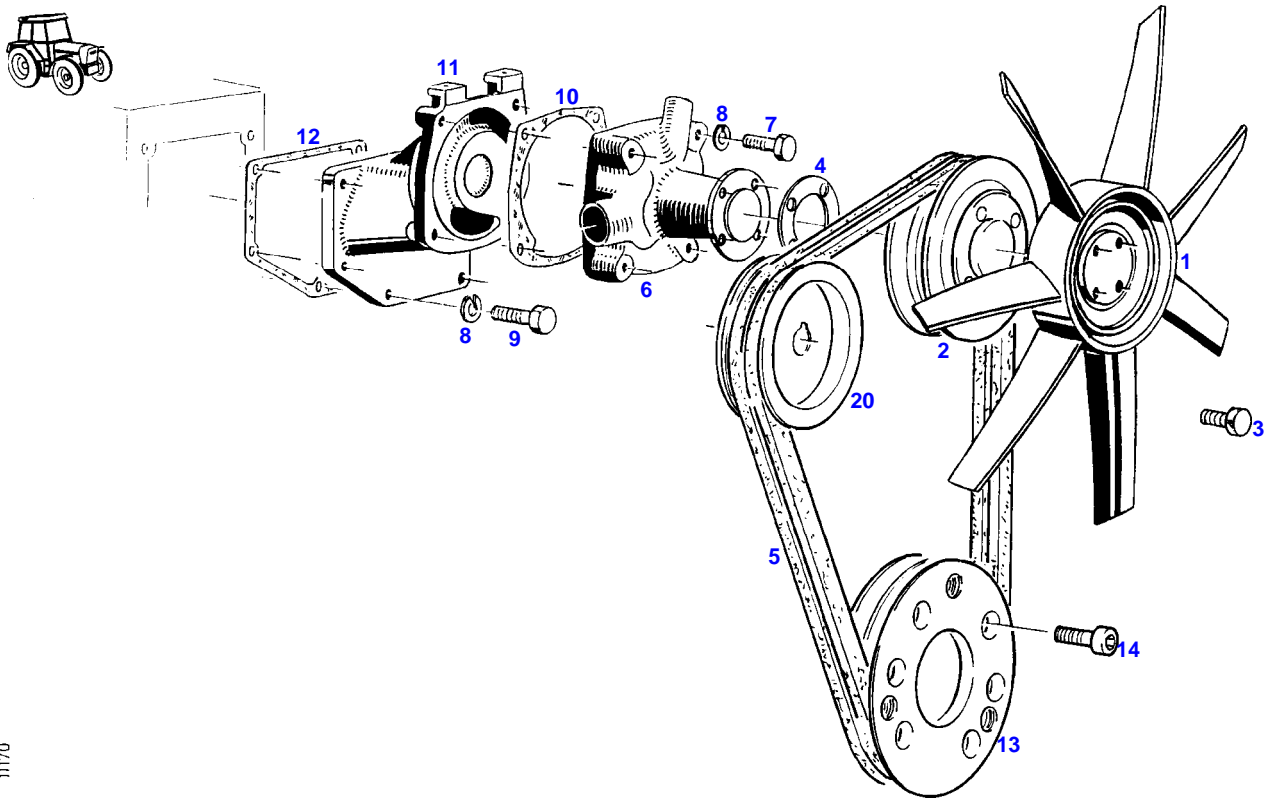

11170

Item	Part Number	Qty	Description Comments	Technical Specification
			<b>AIR CONDITION</b> <-- 162/5001	
1	72331298	1	FAN RANGE OF TEMPERATURE 1	
	72380200	1	FAN RANGE OF TEMPERATURE 2	455/7
2	72396003	1	V BELT SHEAVE	
3	72375063	4	LOCK SCREW RANGE OF TEMPERATURE 1	FWN 64993 M8X22-12.9
	72375067	4	LOCK SCREW RANGE OF TEMPERATURE 2	FWN 64993 M8X35-90
4	72394835	1	DISC RANGE OF TEMPERATURE 1	
5	72379399	1	V-BELT SET (2 PIECE)	FWN66966-2XAVX10X1215LA
6	72340133	1	CENTRIFUGAL PUMP --> 162/6308	
	72343555	1	CENTRIFUGAL PUMP <-- 162/6309	
	72340135	1	REPAIR KIT --> 162/6308 <-- F281.200.610.010	
	72343940	1	REPAIR KIT <-- 162/6309	
7	72315659	4	HEXAGONAL HEAD BOLT	DIN 933 M8X35-8.8
8	72315053	10	SPLIT WASHER	FWN 65208-8-A3L
9	72315654	6	HEXAGONAL HEAD BOLT	DIN 933 M8X28-8.8A3L
10	72328678	1	SEAL	
11	72330788	1	INTERMEDIATE PIECE --> 162/6308 <-- F162.204.610.010	
	72332585	1	INTERMEDIATE PIECE <-- 162/6309	
12			SEE CRANKCASE	
13	72396002	1	V BELT SHEAVE	
14	72315498	6	SOCKET HEAD BOLT	DIN 912 M10X40-8.8 OB1-SW
20			SEE ALTERNATOR ASSY	

FARMER 305 (162/00001-07500)  
1603

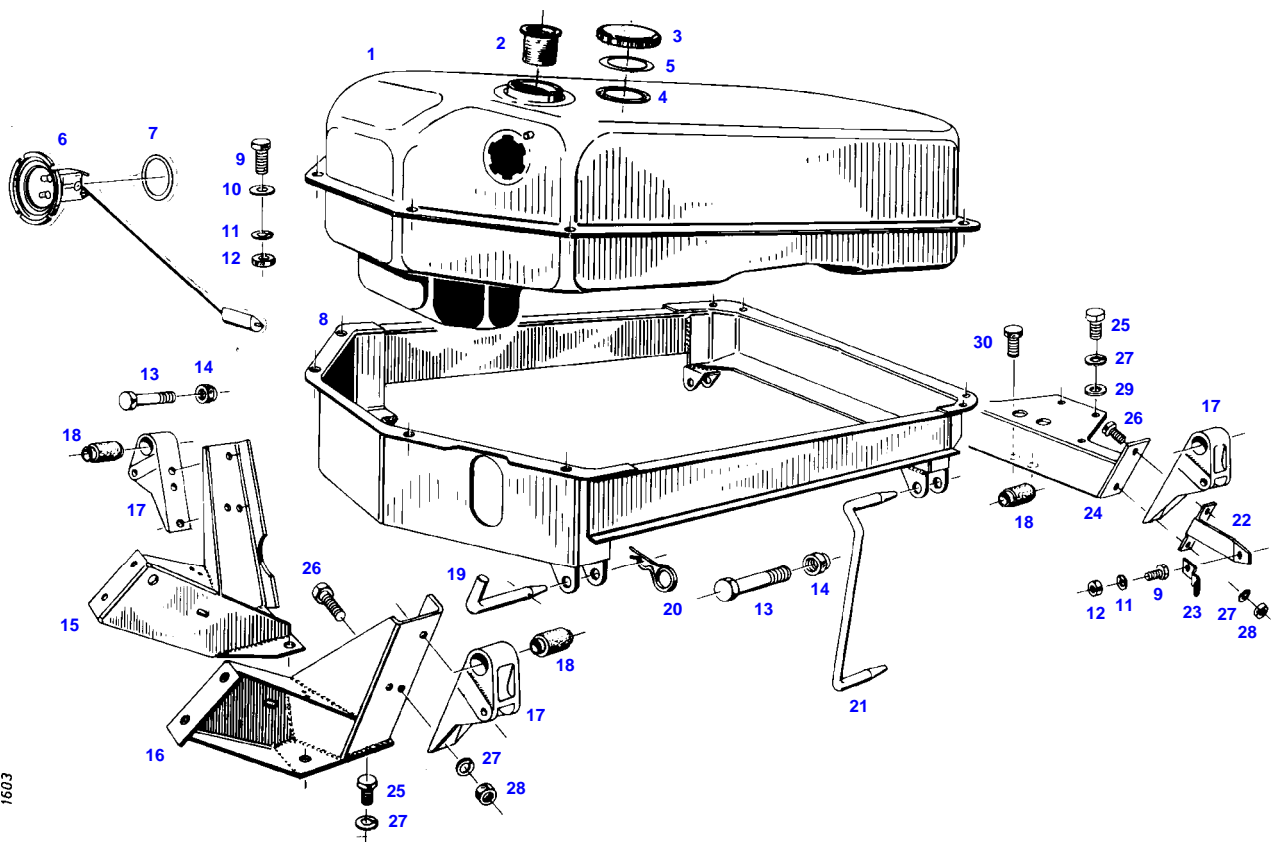

Item	Part Number	Qty	Description Comments	Technical Specification
			--> 162/2813	
1	72349985	1	FUEL TANK ><3 <>	
	72409022	2	FLANGE	
	72376132	2	SEALING WASHER	
	72376018	10	SEALING WASHER	DIN 7603 A5X9-VF
	72315619	10	HEXAGONAL HEAD BOLT	DIN 933 M5X16-8.8A3L
	72348556	1	FUEL LEVEL SENSOR	
	72376017	2	SEALING WASHER	DIN 7603-A5X7,5-CU
2	72380019	1	STRAINER 49MM	
	72433112	1	STRAINER 99MM	60X100-MS
3	72348405	1	FUEL CAP ><4-5 BLAU	
	72348297	1	<-- X810.110.050 1X FUEL CAP ><4-5 LOCKABLE BLAU	
4	72312304	1	RUBBER SEAL KOEHLER	
	72330725	1	SEAL BLAU	
5	72330726	1	SEAL BLAU	
6	72613041	1	FUEL LEVEL SENSOR ><6-7	
7	72315169	1	SEALING WASHER	
8	72357106	1	TANK FRAME	
9	72315626	9	HEXAGONAL HEAD BOLT	DIN 933-M6 X 16-8.8-A3L
	72315631	2	HEXAGONAL HEAD BOLT	DIN 933 M6 X 20-8.8A3L
10	72311822	16	DISC	DIN9021-6,4-140HV-A3L
11	72315052	9	SPLIT WASHER	FWN 65208-6-A3L
12	72313266	9	NUT	DIN 934 M6-8A3L
13	72315719	2	HEXAGONAL HEAD BOLT	DIN 933 M12X60-8.8A3L
14	72313325	2	NUT	DIN 980-VM12-8-A3L
15	72355440	1	BRACKET	
16	72355441	1	BRACKET	
17	72356758	4	SUPPORT ARM <>	
	72315653	1	HEXAGONAL HEAD BOLT	DIN 933 M8 X 25-8.8A3L
	72313268	1	NUT	DIN 934 M8-8A3L
	72311788	1	DISC	DIN 125-8,4-ST.A3L
	72393683	1	ANGLE	
18	72310644	4	RUBBER BUSHING	
19	72407288	1	BEARING PIN	
20	72311183	1	HAIR COTTER PIN	DIN 11024-4-A3L
21	72393676	1	BEARING PIN	
	72393681	1	BEARING PIN WITH FRONTLOADER	
22	72393677	1	RETAINING BRACKET	
23	72393680	1	LEAF SPRING	
24	72355727	1	CROSSMEMBER	
25	72315642	8	HEXAGONAL HEAD BOLT	DIN 933 M8 X 16-8.8A3L
26	72315653	8	HEXAGONAL HEAD BOLT	DIN 933 M8 X 25-8.8A3L
27	72315053	16	SPLIT WASHER	FWN 65208-8-A3L
28	72313268	8	NUT	DIN 934 M8-8A3L
29	72311788	2	DISC	DIN 125-8,4-ST.A3L
30	72315675	2	HEXAGONAL HEAD BOLT	DIN 933 M10X16-8.8A3L

FARMER 305 (162/00001-07500)  
3950

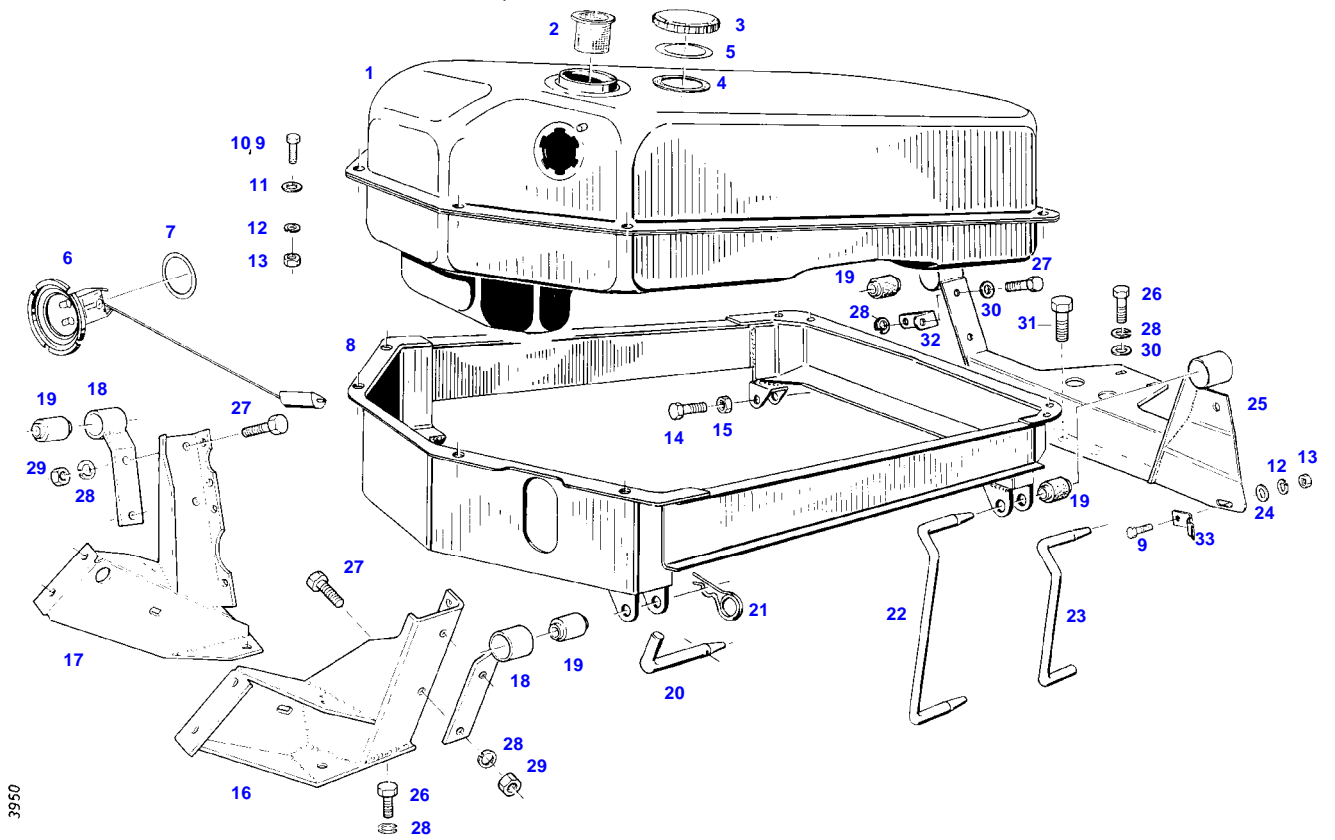

Item	Part Number	Qty	Description Comments	Technical Specification
			<-- 162/2814	
1	72349985	1	FUEL TANK	
			<>	
	72376132	2	SEALING WASHER	
	72315619	10	HEXAGONAL HEAD BOLT	DIN 933 M5X16-8.8A3L
	72376017	2	SEALING WASHER	DIN 7603-A5X7,5-CU
	72409022	2	FLANGE	
	72376018	10	SEALING WASHER	DIN 7603 A5X9-VF
	72348556	1	FUEL LEVEL SENSOR	
2	72433112	1	STRAINER	60X100-MS
3	72380143	1	FUEL CAP KOEHLER	M.BELUEF
			><4	
	72348297	1	FUEL CAP LOCKABLE BLAU	
			><4-5	
4	72312304	1	RUBBER SEAL KOEHLER	
	72330725	1	SEAL BLAU	
5	72330726	1	SEAL	
6	72613041	1	FUEL LEVEL SENSOR	
			><6-7	
7	72315169	1	SEALING WASHER	
8	72357106	1	TANK FRAME	
9	72315626	8	HEXAGONAL HEAD BOLT	DIN 933-M6 X 16-8.8-A3L
	72315631	2	HEXAGONAL HEAD BOLT	DIN 933 M6 X 20-8.8A3L
11	72311822	16	DISC	DIN9021-6,4-140HV-A3L
12	72315052	10	SPLIT WASHER	FWN 65208-6-A3L
13	72313266	10	NUT	DIN 934 M6-8A3L
14	72315719	2	HEXAGONAL HEAD BOLT	DIN 933 M12X60-8.8A3L
15	72313325	2	NUT	DIN 980-VM12-8-A3L
16	72355440	1	BRACKET	
17	72355441	1	BRACKET	
18	72356758	2	SUPPORT ARM	
19	72310644	4	RUBBER BUSHING	
20	72404932	1	BEARING PIN	
21	72311183	1	HAIR COTTER PIN	DIN 11024-4-A3L
22	72393676	1	BEARING PIN	
23	72393681	1	BEARING PIN WITH FRONTLOADER	
24	72311787	1	DISC	DIN 125-6,4-ST.A3L
25	72355727	1	CROSSMEMBER	
26	72315642	9	HEXAGONAL HEAD BOLT	DIN 933 M8 X 16-8.8A3L
27	72315653	5	HEXAGONAL HEAD BOLT	DIN 933 M8 X 25-8.8A3L
28	72315053	14	SPLIT WASHER	FWN 65208-8-A3L
29	72313268	5	NUT	DIN 934 M8-8A3L
30	72311788	3	DISC	DIN 125-8,4-ST.A3L
31	72315675	2	HEXAGONAL HEAD BOLT	DIN 933 M10X16-8.8A3L
32	72393683	1	ANGLE	
33	72393680	1	LEAF SPRING	

FARMER 305 (162/00001-07500)  
1604

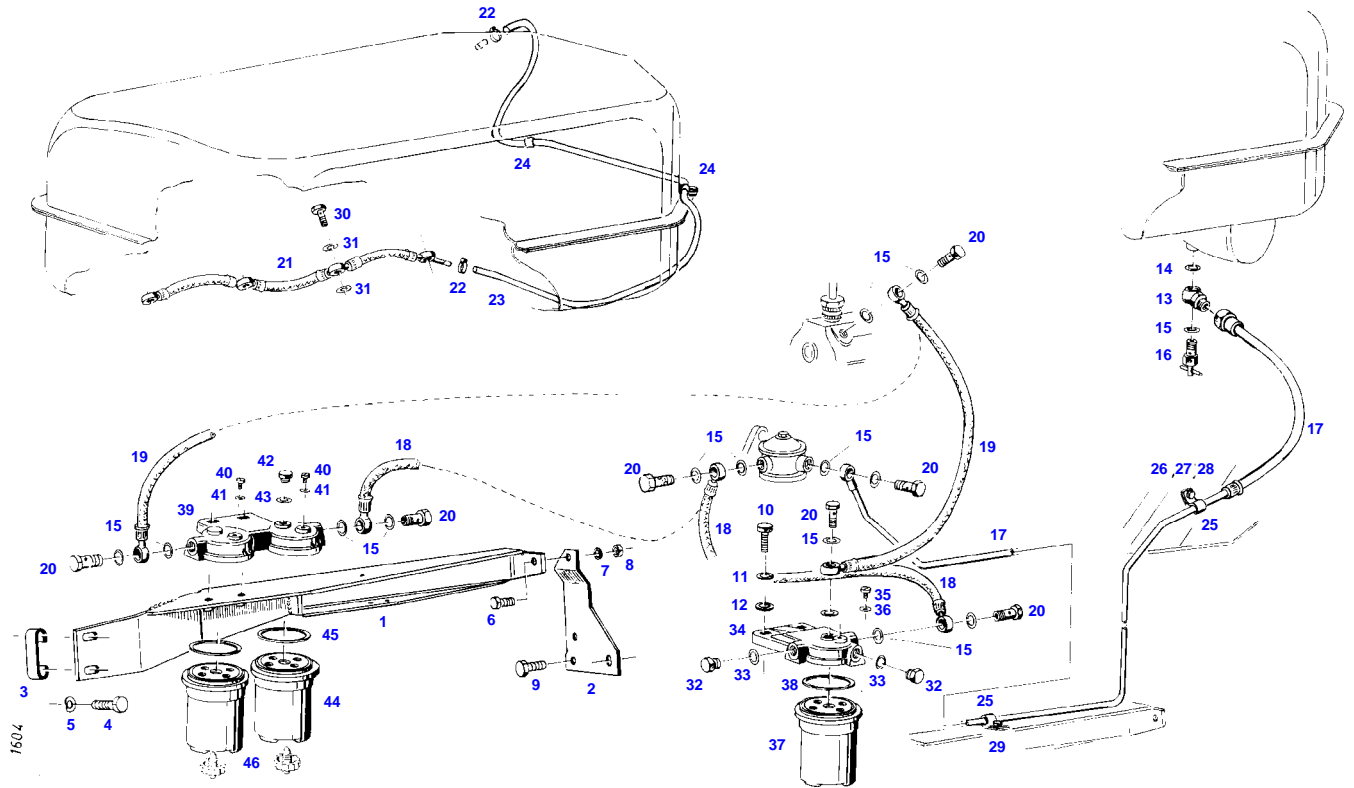

Item	Part Number	Qty	Description Comments	Technical Specification
			--> 162/5000	
1	72356706	1	RETAINER --> 162/0050 <> HYDR.CIRCUIT 1 HYDR.CIRCUIT 2 <>	
	72394404	1	BOOST PIPE	
	72394376	1	BOOST PIPE	
	72394405	1	BOOST PIPE	
2	72393679	1	RETAINING SHEET METAL	
3	72399913	1	HOLDER	
4	72315689	1	HEXAGONAL HEAD BOLT	DIN 933 M10X35-8.8A3L
	72315691	1	HEXAGONAL HEAD BOLT	DIN 933 M10X40-8.8A3L
5	72317122	2	SPRING WASHER	DIN 137 B10-MECH.VZK
6	72315642	1	HEXAGONAL HEAD BOLT	DIN 933 M8 X 16-8.8A3L
7	72315053	1	SPLIT WASHER	FWN 65208-8-A3L
8	72313268	1	NUT	DIN 934 M8-8A3L
9	72374490	2	HEXAGONAL HEAD BOLT	DIN 933 M14X20-8.8
10	72315689	2	HEXAGONAL HEAD BOLT	DIN 933 M10X35-8.8A3L
11	72315054	2	SPLIT WASHER	FWN 65208-10-A3L
12	72311789	2	DISC	DIN 125-10,5-ST.A3L
13	72316302	1	NOZZLE --> 162/1830	LL10 DIN7641/12.69 A3L
14	72315093	1	SEALING WASHER	DIN 7603 A12X18-CU
15	72315095	11	SEALING WASHER	DIN 7603 A14X20-CU
16	72380159	1	FUEL SHUT-OFF VALVE	
17	72348543	1	TUBING --> 162/1830 <> <>	
	72311241	2	PIPE CLAMP	
18	72365147	1	FUEL LINE	
19	72355537	1	FUEL LINE	
20	72315808	2	BANJO BOLT	DIN 7643-10-3-A3L
21	72339360	1	LEAKAGE OIL LINE	
22	72438345	2	HOSE CLIP	
23	72435830	1	PRESSURE HOSE 1150 MM CUT TO LENGTH	L=2100
24	72398941	2	FASTENING COLLAR	
25	72373547	2	PIPE CLAMP --> 162/1830	
	72311241	2	PIPE CLAMP <-- 162/1831	
26	72315626	1	HEXAGONAL HEAD BOLT	DIN 933-M6 X 16-8.8-A3L
27	72315052	1	SPLIT WASHER	FWN 65208-6-A3L
	72311787	1	DISC	DIN 125-6,4-ST.A3L
28	72313266	1	NUT	DIN 934 M6-8A3L
29	72315626	1	HEXAGONAL HEAD BOLT	DIN 933-M6 X 16-8.8-A3L
	72313266	1	NUT	DIN 934 M6-8A3L
	72315052	1	SPLIT WASHER	FWN 65208-6-A3L
30	72315809	4	BANJO BOLT	DIN 7643-4-5-A3L
31	72315086	8	SEALING WASHER	DIN 7603 A8X11,5-CU
32	72315799	2	PLUG	DIN 7604 AM14X1,5-A3L
33	72315095	2	SEALING WASHER	DIN 7603 A14X20-CU
34			SEE FUEL FILTER	
35			SEE FUEL FILTER	
36			SEE FUEL FILTER	
37			SEE FUEL FILTER	
38			SEE FUEL FILTER	

---

Fendt

FARMER 305 (162/00001-07500)

F162000

FUEL LINES

Page01-0016

---

Item	Part Number	Qty	Description Comments	Technical Specification
39			SEE FUEL FILTER	
40			SEE FUEL FILTER	
41			SEE FUEL FILTER	
42			SEE FUEL FILTER	
43			SEE FUEL FILTER	
44			SEE FUEL FILTER	
45			SEE FUEL FILTER	
46	72380174	1	SEE FUEL FILTER SCREW	

FARMER 305 (162/00001-07500)  
40848

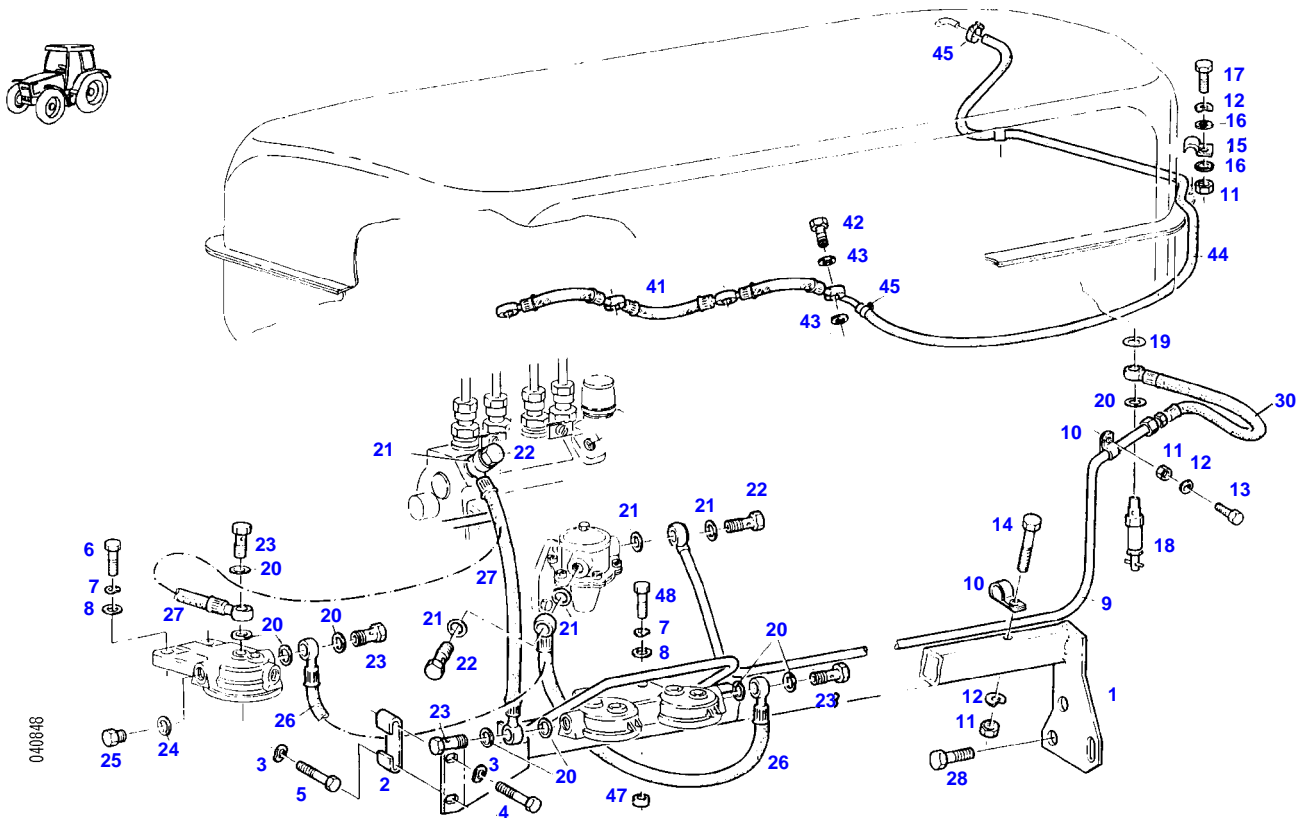

Item	Part Number	Qty	Description Comments	Technical Specification
			<-- 162/5001	
1	72356743	1	RETAINER	
2	72399913	1	HOLDER	
3	72317122	2	SPRING WASHER	DIN 137 B10-MECH.VZK
4	72315689	1	HEXAGONAL HEAD BOLT	DIN 933 M10X35-8.8A3L
5	72315691	1	HEXAGONAL HEAD BOLT	DIN 933 M10X40-8.8A3L
6	72315657	2	HEXAGONAL HEAD BOLT	DIN 933 M8 X 30-8.8A3L
7	72315053	2	SPLIT WASHER	FWN 65208-8-A3L
8	72311824	2	DISC	DIN9021-8,4-140HV-A3L
9	72356707	1	TUBING	
10	72311241	2	PIPE CLAMP	
11	72313266	3	NUT	DIN 934 M6-8A3L
12	72315052	3	SPLIT WASHER	FWN 65208-6-A3L
13	72315626	1	HEXAGONAL HEAD BOLT	DIN 933-M6 X 16-8.8-A3L
	72311787	1	DISC	DIN 125-6,4-ST.A3L
			NOT ILLUSTRATED	
14	72315637	1	HEXAGONAL HEAD BOLT	DIN 933 M6X45-8.8A3L
15	72398941	2	FASTENING COLLAR	
16	72311822	4	DISC	DIN9021-6,4-140HV-A3L
17	72315631	2	HEXAGONAL HEAD BOLT	DIN 933 M6 X 20-8.8A3L
18	72380159	1	FUEL SHUT-OFF VALVE	
19	72315093	1	SEALING WASHER	DIN 7603 A12X18-CU
20	72315095	5	SEALING WASHER	DIN 7603 A14X20-CU
21	72315095	6	SEALING WASHER	DIN 7603 A14X20-CU
22	72315808	3	BANJO BOLT	DIN 7643-10-3-A3L
23	72315808	2	BANJO BOLT	DIN 7643-10-3-A3L
24	72315095	2	SEALING WASHER	DIN 7603 A14X20-CU
25	72315799	2	PLUG	DIN 7604 AM14X1,5-A3L
26	72356760	1	FUEL LINE	
27	72355537	1	FUEL LINE	
28	72374490	2	HEXAGONAL HEAD BOLT	DIN 933 M14X20-8.8
	72374493	2	HEXAGONAL HEAD BOLT	DIN 933 M14X30-8.8
30	72357312	1	HOSE LINE	
41	72339360	1	LEAKAGE OIL LINE	
42	72315809	4	BANJO BOLT	DIN 7643-4-5-A3L
43	72315086	8	SEALING WASHER	DIN 7603 A8X11,5-CU
44	72378086	1	PRESSURE HOSE	FWN 66041-P4
45	72438345	2	HOSE CLIP	
47	72311848	2	DISC	
48	72315660	2	HEXAGONAL HEAD BOLT	DIN 933 M8X35-8.8A3L

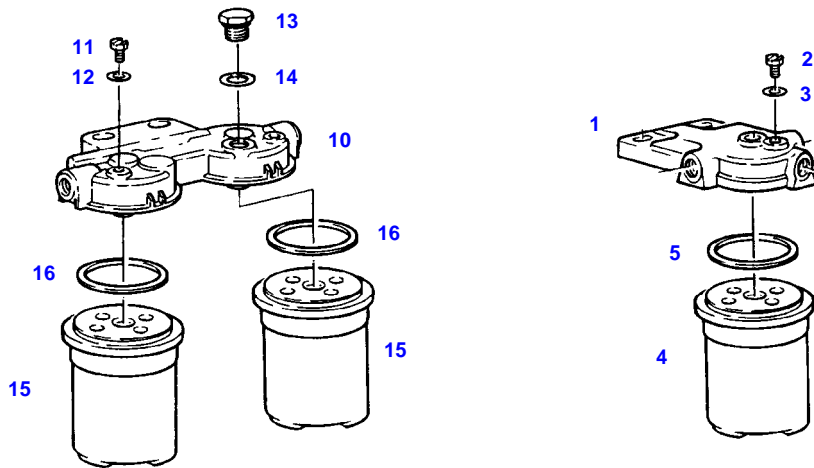

4952

Item	Part Number	Qty	Description Comments	Technical Specification
1	72615599	1	FILTER LID ><2,3	
2	72323290	1	BLEED SCREW	
3	72315084	1	SEALING WASHER	DIN 7603 A6X10-CU
4	72416928	1	FILTER BOX ><5	
5	72314995	1	RUBBER RING PARALLEL-FILTER	
10	72380173	1	PARALLEL FILTER BOSCH ><11-16 <-- X810.190.166.000 1X <>	
	72416928	2	FILTER BOX	
	72451307	1	COVER KNECHT ><11,12 <>	PARALLELFILT.
	72416928	2	FILTER BOX	
11	72323290	2	BLEED SCREW BOSCH	
	72314699	2	BLEED SCREW KNECHT	
12	72315084	2	SEALING WASHER BOSCH	DIN 7603 A6X10-CU
	72315086	2	SEALING WASHER KNECHT	DIN 7603 A8X11,5-CU
13	72326250	1	SCREW BOSCH	
14	72315095	1	SEALING WASHER BOSCH	DIN 7603 A14X20-CU
15	72416928	2	FILTER BOX ><16	
16	72314995	2	RUBBER RING	

FARMER 305 (162/00001-07500)  
1608

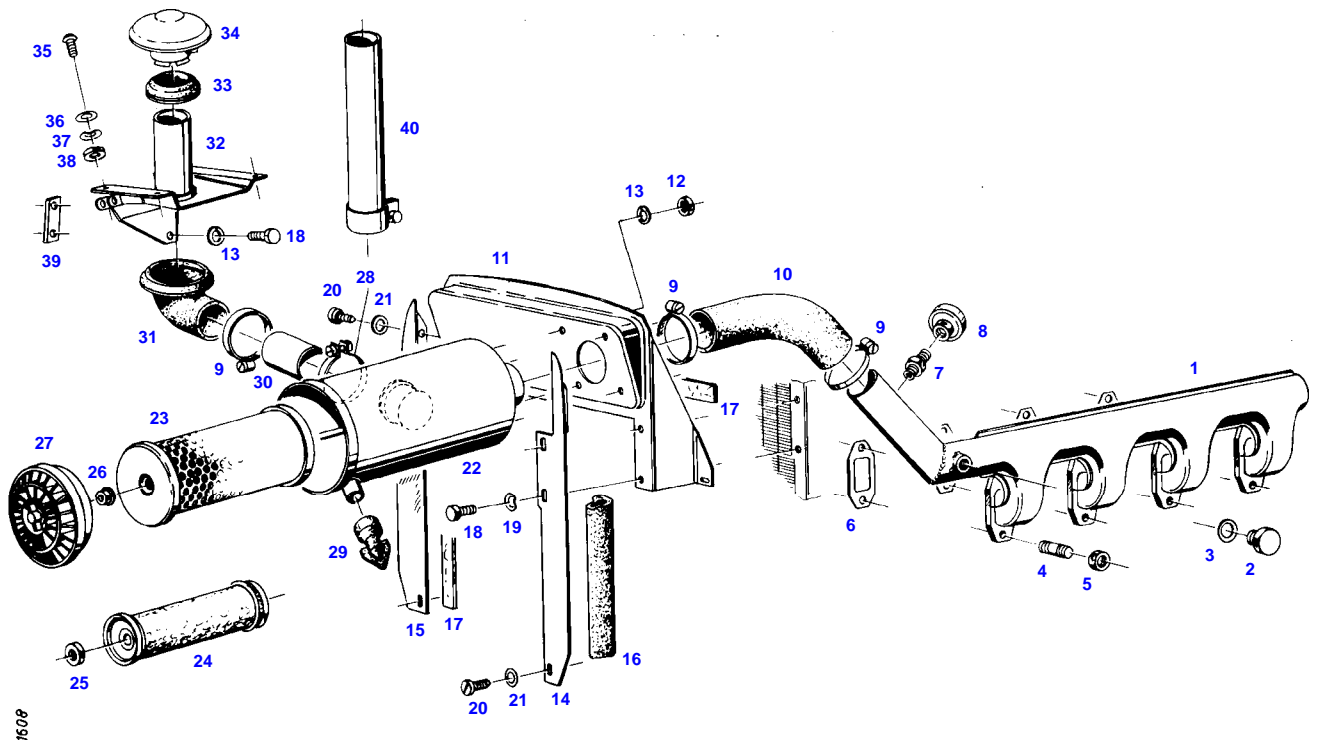

Item	Part Number	Qty	Description Comments	Technical Specification
			--> 162/6145	
1	72355728	1	INTAKE MANIFOLD	
	72355729	1	INTAKE MANIFOLD AIR BRAKING SYSTEM	
2	72373975	1	SCREW	DIN 910 M20X1,5-ST
3	72376031	1	SEALING WASHER	DIN 7603 A20X24-CU
4	72373922	8	STUD BOLT	DIN 835-M10X25-8.8
5	72313272	8	NUT	DIN 934 M10-8A3L
6	72332145	4	MOLDED SEAL	
7	72339032	1	THREADED SOCKET	
8	72316876	1	MAINTENANCE SWITCH --> 162/5155 <> <>	
	72379171	0	WIRE	B1 DIN72551/6.51 SCHWARZ
	72380356	1	CABLE LUG	
	72314686	1	PLUG IN SLEEVE	
9	72373528	3	HOSE CLIP	
10	72393689	1	RUBBER ARCH	
11	72392142	1	FILTER BRACKET --> 162/5768 <> <-- 162/5769 <> <>	
	72315052	1	SPLIT WASHER	FWN 65208-6-A3L
	72311787	1	DISC	DIN 125-6,4-ST.A3L
	72315626	1	HEXAGONAL HEAD BOLT	DIN 933-M6 X 16-8.8-A3L
	72314744	1	LOCKING PLUG	F4
	72311810	1	DISC	DIN 7989 A11-ST.A3L
	72313266	1	NUT	DIN 934 M6-8A3L
12	72313268	4	NUT	DIN 934 M8-8A3L
13	72315053	7	SPLIT WASHER	FWN 65208-8-A3L
14	72392834	1	SPLASH PANEL	
15	72392835	1	SPLASH PANEL	
16	72393692	1	SEALING PROFILE	
17			NO SPARE PART	
18	72315645	6	HEXAGONAL HEAD BOLT	DIN 933 M8 X 12-8.8A3L
19	72317121	4	SPRING WASHER --> 162/5768	DIN 137 B8-MECH.VZK
	72317121	3	SPRING WASHER <-- 162/5769	DIN 137 B8-MECH.VZK
	72315052	1	SPLIT WASHER <-- 162/5769	FWN 65208-6-A3L
20	72315785	4	SCREW --> 162/5768	DIN 7981 ST4,2X9,5-C-H-A3
	72315785	3	SCREW <-- 162/5769	DIN 7981 ST4,2X9,5-C-H-A3
	72315626	1	HEXAGONAL HEAD BOLT <-- 162/5769	DIN 933-M6 X 16-8.8-A3L
21	72311817	4	DISC --> 162/5768	DIN9021-4,3-140HV-A3L
	72311817	3	DISC <-- 162/5769	DIN9021-4,3-140HV-A3L
	72311787	1	DISC <-- 162/5769	DIN 125-6,4-ST.A3L
	72313266	1	NUT <-- 162/5769	DIN 934 M6-8A3L
	72314744	1	LOCKING PLUG <-- 162/5769	F4
22	72348100	1	AIR FILTER	
	72315785	3	SCREW	DIN 7981 ST4,2X9,5-C-H-A3
23	72329734	1	MICRO-TOP CARTRIDGE	
24	72329735	1	SAFETY CARTRIDGE	
25	72372827	1	NUT	DIN 934 M16X1,5-10A3L
26	72339030	1	COLLAR NUT	

Item	Part Number	Qty	Description Comments	Technical Specification
27	72329736	1	FLOOR	
	72389314	1	ABSORPTION INDICATOR	
28	72329737	1	PIPE CLAMP	
			<-- X458.648.500.000	
29	72326122	1	DUST DISCHARGE VALVE	
30	72393687	1	CONNECTING PIPE	
31	72393688	1	BELLOWS	
32	72355730	1	AIR INTAKE	
33	72393690	1	SEALING RING	
34	72330730	1	RAIN CAP	
35	72373806	4	TRUSS HEAD SCREW	DIN 603 M6X16-A3L
36	72311788	8	DISC	DIN 125-8,4-ST.A3L
	72311787	4	DISC	DIN 125-6,4-ST.A3L
37	72315052	4	SPLIT WASHER	FWN 65208-6-A3L
38	72313266	4	NUT	DIN 934 M6-8A3L
39	72393790	1	THREADED PLATE	
40			NO SPARE PART	

FARMER 305 (162/00001-07500)  
4272

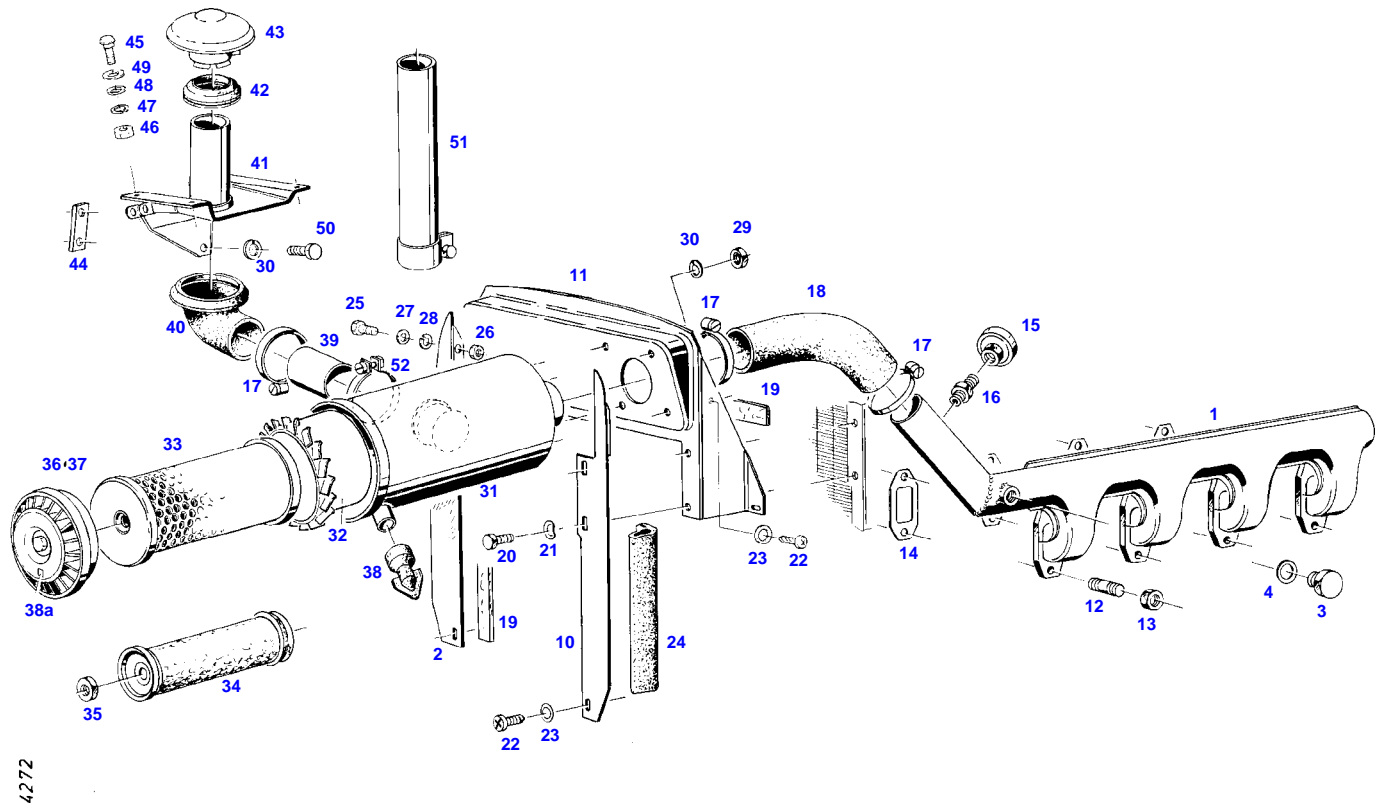

Item	Part Number	Qty	Description Comments	Technical Specification
			<-- 162/6146	
1	72355728	1	INTAKE MANIFOLD	
	72355729	1	INTAKE MANIFOLD WITH AIR BRAKING SYSTEM	
2	72392835	1	SPLASH PANEL	
	72392143	1	SPLASH PANEL WITH AIR CONDITION	
3	72373975	1	SCREW	DIN 910 M20X1,5-ST
4	72376031	1	SEALING WASHER	DIN 7603 A20X24-CU
10	72392834	1	SPLASH PANEL	
11	72392142	1	FILTER BRACKET	
12	72373922	8	STUD BOLT	DIN 835-M10X25-8.8
13	72373015	8	NUT	DIN70615-M10-8-A3B
14	72332145	4	MOLDED SEAL	
15	72316876	1	MAINTENANCE SWITCH	
16	72339032	1	THREADED SOCKET --> 162/6930	
17	72373528	3	HOSE CLIP	
18	72393689	1	RUBBER ARCH	
19			NO SPARE PART	
20	72315645	4	HEXAGONAL HEAD BOLT	DIN 933 M8 X 12-8.8A3L
21	72317121	4	SPRING WASHER	DIN 137 B8-MECH.VZK
22	72315785	3	SCREW	DIN 7981 ST4,2X9,5-C-H-A3
23	72311817	3	DISC	DIN9021-4,3-140HV-A3L
24	72393692	1	SEALING PROFILE	
25	72315626	1	HEXAGONAL HEAD BOLT	DIN 933-M6 X 16-8.8-A3L
26	72313266	2	NUT	DIN 934 M6-8A3L
27	72311787	2	DISC	DIN 125-6,4-ST.A3L
28	72315052	2	SPLIT WASHER	FWN 65208-6-A3L
29	72313268	4	NUT	DIN 934 M8-8A3L
30	72315053	6	SPLIT WASHER	FWN 65208-8-A3L
31	72348100	1	AIR FILTER ><31-38	
32	72329111	1	DIFFUSER	
33	72329734	1	MICRO-TOP CARTRIDGE	
34	72329735	1	SAFETY CARTRIDGE	
35	72372827	1	NUT	DIN 934 M16X1,5-10A3L
36	72329736	1	FLOOR	
38	72326122	1	DUST DISCHARGE VALVE	
	72389314	1	ABSORPTION INDICATOR	
39	72393687	1	CONNECTING PIPE	
40	72393688	1	BELLOWS	
41	72355730	1	AIR INTAKE	
42	72393690	1	SEALING RING	
43	72330730	1	RAIN CAP	
44	72393790	1	THREADED PLATE	
45	72373806	4	TRUSS HEAD SCREW	DIN 603 M6X16-A3L
46	72313266	5	NUT	DIN 934 M6-8A3L
47	72315052	4	SPLIT WASHER	FWN 65208-6-A3L
48	72311787	4	DISC	DIN 125-6,4-ST.A3L
49	72311788	4	DISC	DIN 125-8,4-ST.A3L
50	72315645	2	HEXAGONAL HEAD BOLT	DIN 933 M8 X 12-8.8A3L
51			NO LONGER AVAILABLE	
52	72329737	1	PIPE CLAMP <-- X458.648.500.000	

FARMER 305 (162/00001-07500)  
5424

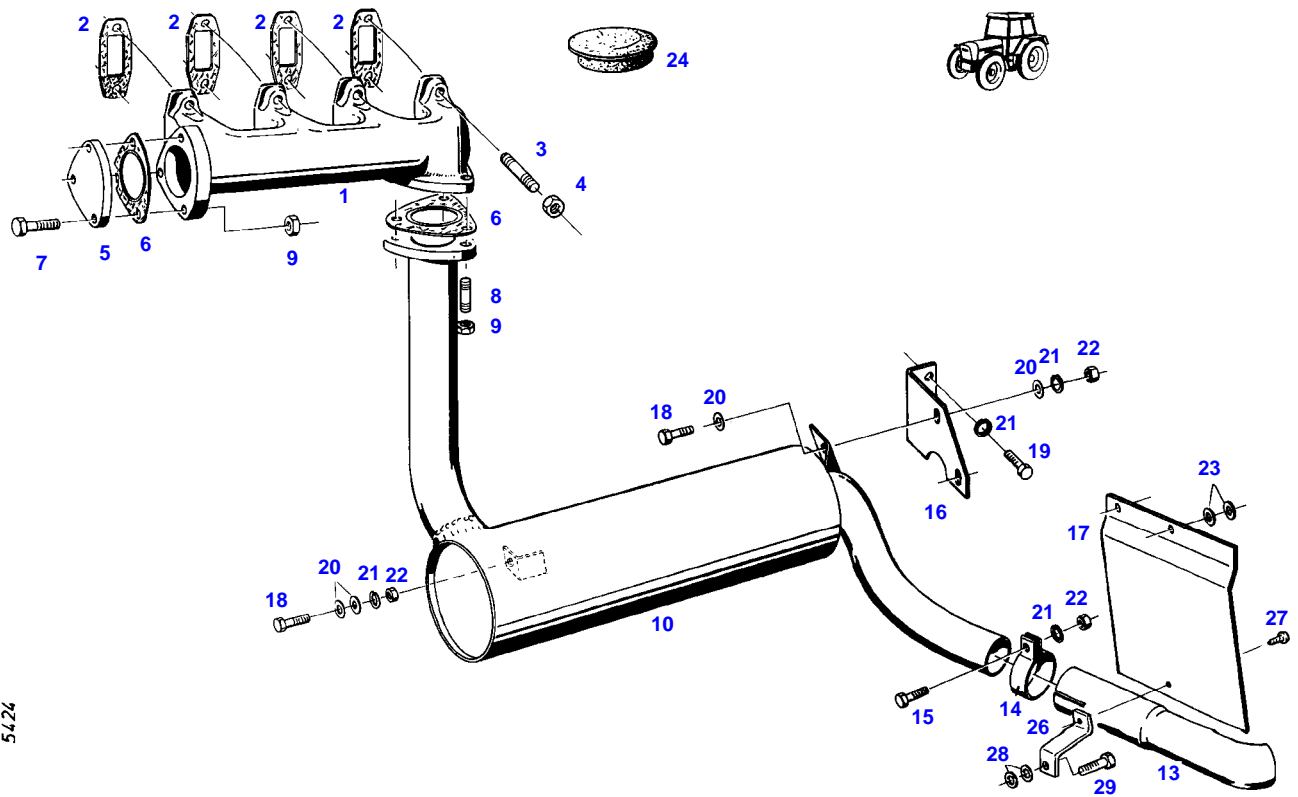

5424

Item	Part Number	Qty	Description Comments	Technical Specification
1	72393699	1	EXHAUST COLLECTING PIPE	
2	72332145	4	MOLDED SEAL	
3	72313777	8	STUD BOLT	DIN 939 M10X35-8.8
4	72313272	8	NUT	DIN 934 M10-8A3L
5	72393700	1	BLANK FLANGE	
6	72407298	2	MOLDED SEAL	
7	72315660	3	HEXAGONAL HEAD BOLT	DIN 933 M8X35-8.8A3L
8	72313770	3	STUD BOLT	FWN64891-M8X20-8.8
9	72313269	6	NUT	DIN 934 M8-8C2A
10	72355733	1	EXHAUST MUFFLER	
	72355734	1	EXHAUST MUFFLER FOR FRONT LOAD.WITH MOUNTING FRAME	
	72355736	1	EXHAUST MUFFLER TO WELD IN	
13	72393695	1	EXHAUST TAILPIPE	
14	72373437	1	PIPE CLAMP	DIN71555-63,5 EDELSTAHL
15	72315657	1	HEXAGONAL HEAD BOLT	DIN 933 M8 X 30-8.8A3L
16	72396312	1	RETAINING BRACKET	
17	72395464	1	DEFLECTOR	
18	72315646	3	HEXAGONAL HEAD BOLT	DIN 933 M8X18-8.8A3L
19	72315642	2	HEXAGONAL HEAD BOLT	DIN 933 M8 X 16-8.8A3L
20	72311788	6	DISC	DIN 125-8,4-ST.A3L
21	72315053	6	SPLIT WASHER	FWN 65208-8-A3L
22	72313268	4	NUT	DIN 934 M8-8A3L
23	72311824	4	DISC	DIN9021-8,4-140HV-A3L
24	72395945	1	COVER	
26	72393697	1	RETAINER	
27	72315820	1	SCREW	DIN7976-ST6,3X13-C-A3L
28	72311824	2	DISC	DIN9021-8,4-140HV-A3L
29	72315657	3	HEXAGONAL HEAD BOLT	DIN 933 M8 X 30-8.8A3L

FARMER 305 (162/00001-07500)  
5423

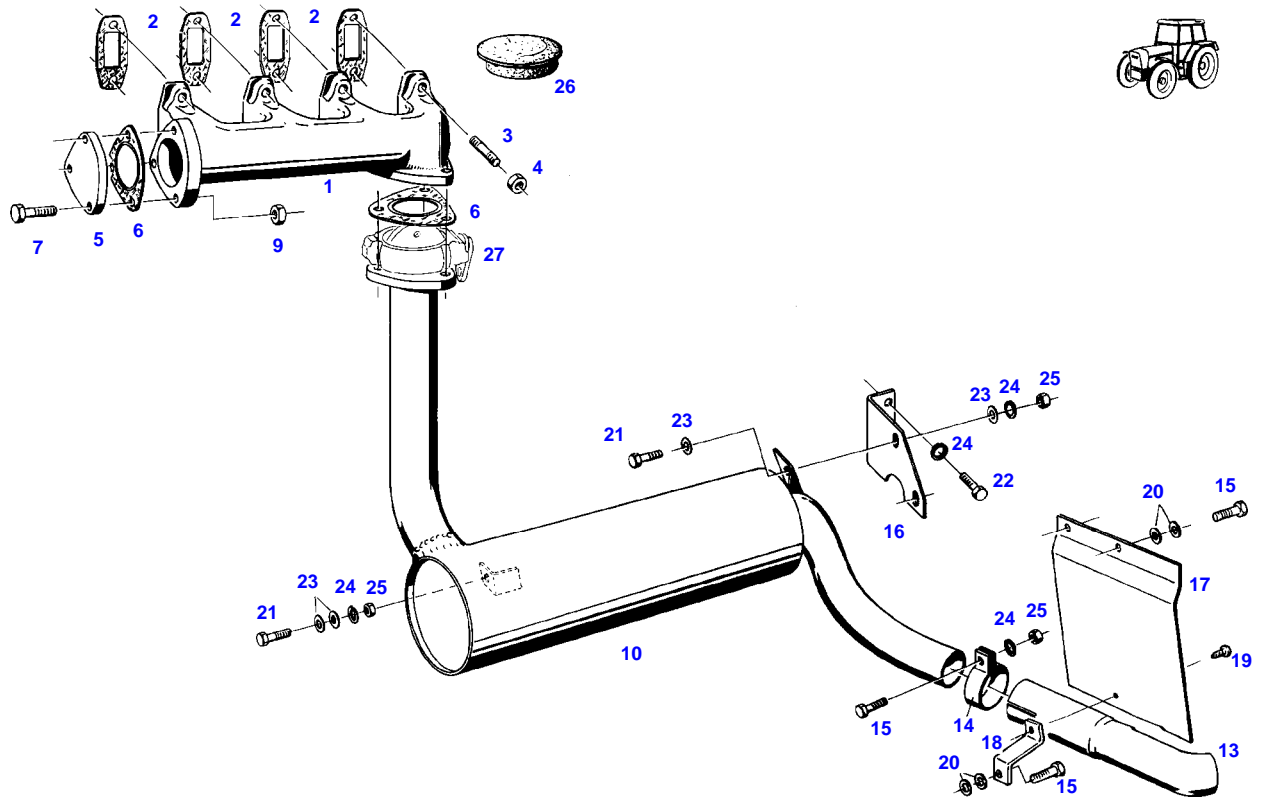

5423

Item	Part Number	Qty	Description Comments	Technical Specification
			<b>ENGINE BRAKE</b> <b>&lt;-- 162/2742</b>	
1	72393699	1	EXHAUST COLLECTING PIPE	
2	72332145	4	MOLDED SEAL	
3	72313777	8	STUD BOLT	DIN 939 M10X35-8.8
4	72313272	8	NUT	DIN 934 M10-8A3L
5	72393700	1	BLANK FLANGE	
6	72407298	1	MOLDED SEAL	
7	72315660	3	HEXAGONAL HEAD BOLT	DIN 933 M8X35-8.8A3L
9	72313269	3	NUT	DIN 934 M8-8C2A
10	72355740	1	EXHAUST MUFFLER	
	72355741	1	EXHAUST MUFFLER FOR FRONT LOAD.WITH MOUNTING FRAME	
	72355736	1	EXHAUST MUFFLER TO WELD IN	
13	72393695	1	EXHAUST TAILPIPE	
14	72373437	1	PIPE CLAMP	DIN71555-63,5 EDELSTAHL
15	72315657	4	HEXAGONAL HEAD BOLT	DIN 933 M8 X 30-8.8A3L
16	72396312	1	RETAINING BRACKET	
17	72395464	1	DEFLECTOR	
18	72393697	1	RETAINER	
19	72315820	1	SCREW	DIN7976-ST6,3X13-C-A3L
20	72311824	6	DISC	DIN9021-8,4-140HV-A3L
21	72315646	3	HEXAGONAL HEAD BOLT	DIN 933 M8X18-8.8A3L
22	72315642	2	HEXAGONAL HEAD BOLT	DIN 933 M8 X 16-8.8A3L
23	72311788	6	DISC	DIN 125-8,4-ST.A3L
24	72315053	6	SPLIT WASHER	FWN 65208-8-A3L
25	72313266	4	NUT	DIN 934 M6-8A3L
26	72395945	1	COVER	
27			SEE ENGINE BRAKE	



**Suggest:**

**For more complete manuals. Please go to the home page.**

**<https://www.ebooklibonline.com>**

**If the above button click is invalid. Please download this document first, and then click the above link to download the complete manual.**

**Thank you so much for reading**

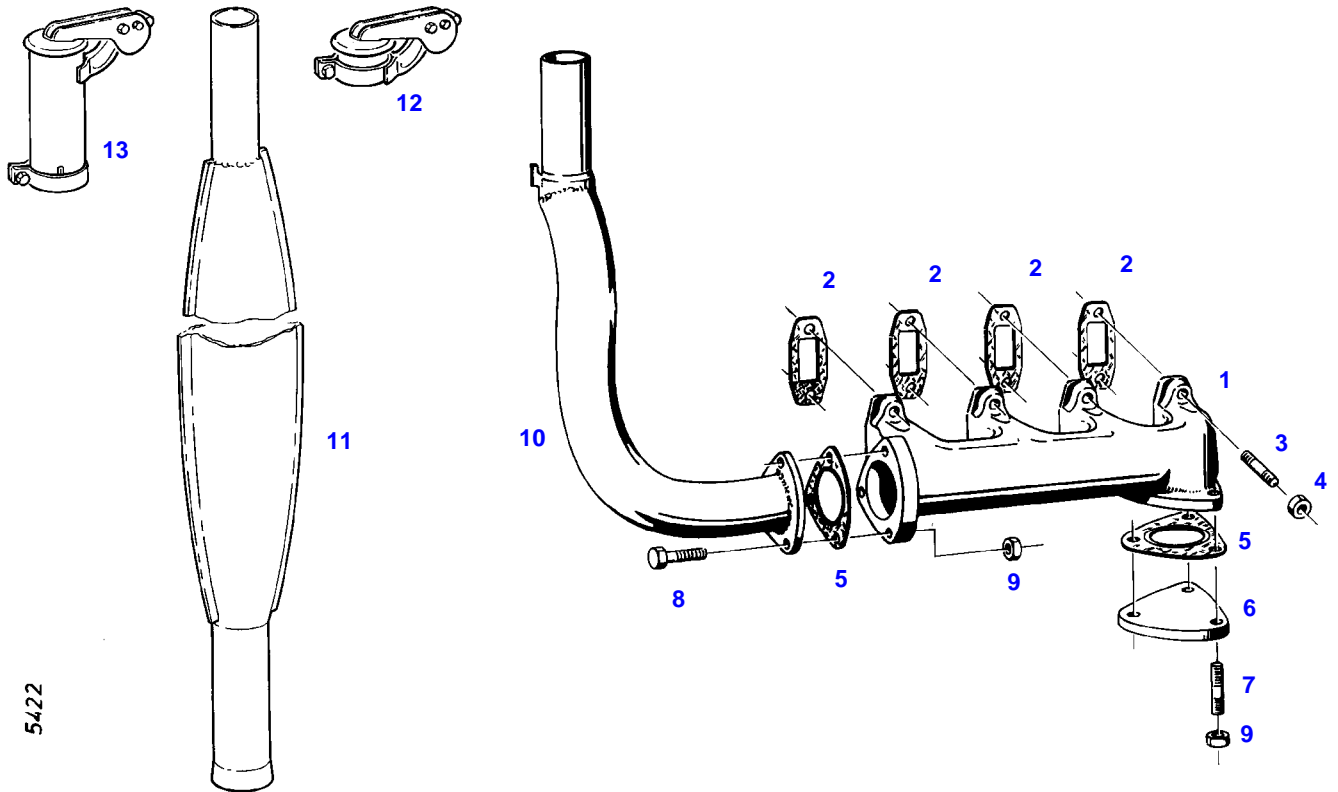

Item	Part Number	Qty	Description Comments	Technical Specification
1	72393699	1	EXHAUST COLLECTING PIPE	
2	72332145	4	MOLDED SEAL	
3	72313777	8	STUD BOLT	DIN 939 M10X35-8.8
4	72313272	8	NUT	DIN 934 M10-8A3L
5	72407298	2	MOLDED SEAL	
6	72393700	1	BLANK FLANGE	
7	72313770	3	STUD BOLT	FWN64891-M8X20-8.8
8	72315660	3	HEXAGONAL HEAD BOLT	DIN 933 M8X35-8.8A3L
9	72313269	6	NUT	DIN 934 M8-8C2A
10	72355737	1	EXHAUST PIPE	
11	72355738	1	EXHAUST MUFFLER	
	72355738	1	EXHAUST MUFFLER SWEDEN CABIN-ROOF HIGH --> 162/6251 <> <>	
	72383243	1	EXHAUST EXTENSION	
	72355754	1	SPARK ARRESTER AUSTRALIA	
12	72347590	1	EXHAUST WEATHER CAP	
13	72383243	1	EXHAUST EXTENSION ><12 <-- 162/6252	

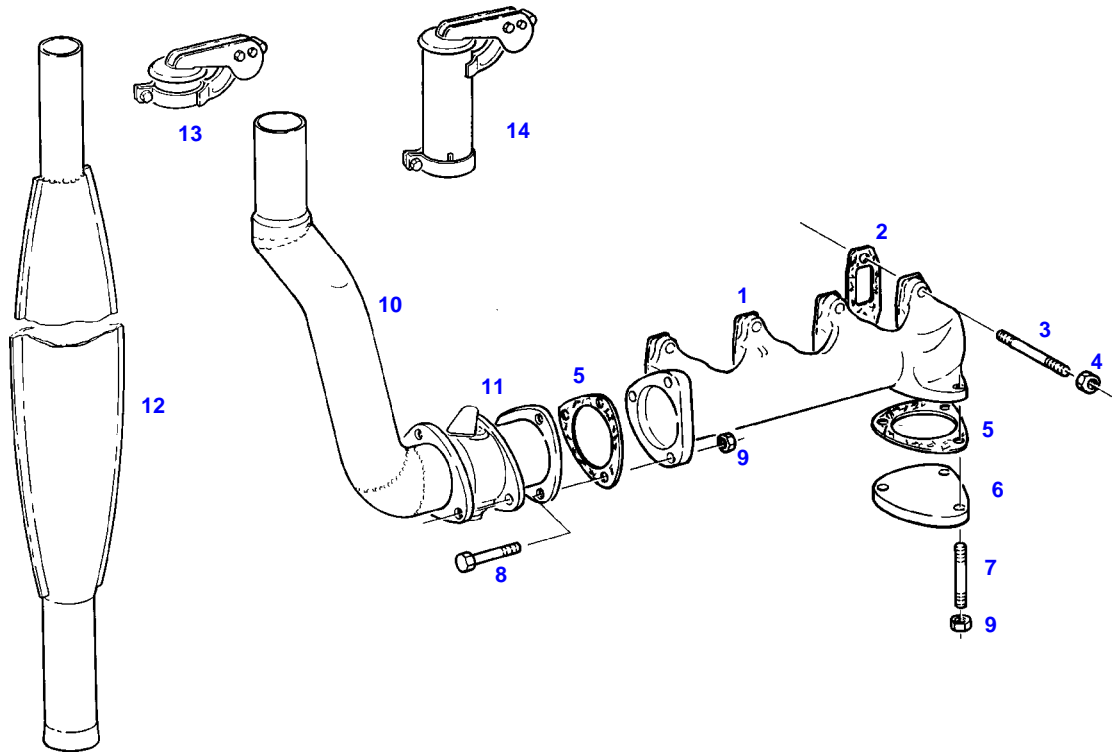

5421

**<https://www.ebooklibonline.com>**

Hello dear friend!

Thank you very much for reading.

Enter the link into your browser.

The full manual is available for immediate download.

**<https://www.ebooklibonline.com>**