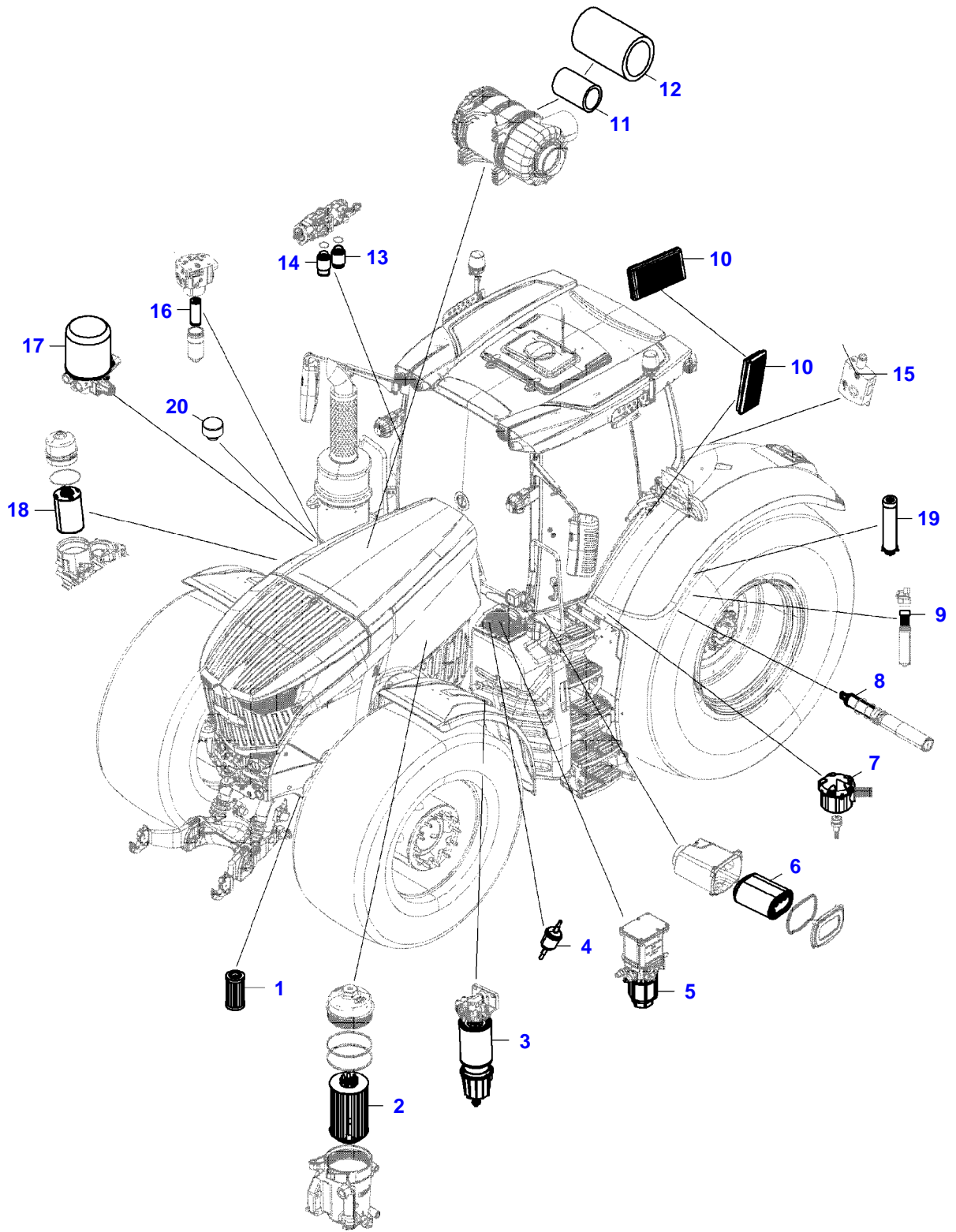

TABLE OF CONTENT

Page Number	Page Title	Page Reference
01-000-TOC	ENGINE, FUEL AND EXHAUST SYSTEM	01-000-TOC
02-000-TOC	AXLES	02-000-TOC
03-000-TOC	STEERING SYSTEM	03-000-TOC
04-000-TOC	DRIVE TRAIN SYSTEM	04-000-TOC
05-000-TOC	COMPRESSED AIR SYSTEM	05-000-TOC
06-000-TOC	HYDRAULIC SYSTEM	06-000-TOC
07-000-TOC	ELECTRICAL SYSTEM	07-000-TOC
08-000-TOC	CAB	08-000-TOC
09-000-TOC	AIR CONDITIONING AND HEATING SYSTEM	09-000-TOC
10-000-TOC	CHASSIS	10-000-TOC
11-000-TOC	DECALS	11-000-TOC
12-000-TOC	WHEELS	12-000-TOC
13-000-TOC	IMPLEMENT LIFT SYSTEM FRONT	13-000-TOC
14-000-TOC	IMPLEMENT LIFT SYSTEM REAR	14-000-TOC
15-000-TOC	LINKAGE	15-000-TOC
16-000-TOC	PRECISION FARMING SYSTEMS	16-000-TOC
17-000-TOC	ACCESSORIES	17-000-TOC



14430928-M-1

Item	Part Number	Qty	Description Comments	Technical Specification
1	72623924	1	FILTER AXLE HOUSING SEE PAGE 02-0002	FILTEREINSATZ-VORDERACHSE
2	ACP0153530	1	FILTER ELEMENT FUEL FILTER SEE PAGE 01-0020	
3	72614253	1	FILTER ELEMENT PRE FUEL FILTER SEE PAGE 01-0021	
4	72484191	1	FILTER PREFILTER ADBLUE SEE PAGE 01-0050	
5	ACP0153520	1	DEF FILTER ADBLUE SEE PAGE 01-0050	
6	72620540	1	FILTER CARTRIDGE FRESH AIR SEE PAGE 08-0043	
7	ACP0225000	1	FILTER ELEMENT FUEL AIR CLEANER SEE PAGE 01-0022	
8	72621035	1	FILTER ELEMENT PUMP DRIVE SEE PAGE 04-0052	GETRIEBEOEL
9	72488569	1	FILTER ELEMENT VALVES COMFORT SYSTEM SEE PAGE 04-0055	
10	72620539	2	FILTER CAB AIR RECIRCULATION SEE PAGE 08-0042	
11	72622475	1	SECONDARY AIR FILTER ELEMENT SEE PAGE 01-0042	
12	72622474	1	PRIMARY AIR FILTER ELEMENT SEE PAGE 01-0042	
13	72438395	1	SUCTION FILTER OIL TANK SEE PAGE 14-0007	
14	72451933	1	SUCTION FILTER OIL TANK SEE PAGE 14-0007	
15	72470364	1	FILTER END PLATE SEE PAGE 06-0045	
16	72493246	1	HYDRAULIC FILTER CENTRAL CONTROL BLOCK SEE PAGE 06-0077	STEUERDRUCK
17	72437515	1	CARTRIDGE JET AIR DRIER SEE PAGE 05-0005	LUFTTROCKNER
18	ACP0154860	1	FILTER CARTRIDGE OIL FILTER SEE PAGE 01-0016	
19	72620607	1	RETURN FILTER OIL TANK SEE PAGE 14-0007	
20	72364577	1	VENTILATION FILTER OIL FILLING SOCKET SEE PAGE 14-0004 FROM - UP TO MACHINE S/N 530/1001 - 530/1284	

<https://www.ebooklibonline.com>

Hello dear friend!

Thank you very much for reading.

Enter the link into your browser.

The full manual is available for immediate download.

<https://www.ebooklibonline.com>

Fendt

FENDT 1050 S4 (530/00101-05000) (WAM530XXX00F05001-99999)

F530000

OVERVIEW - FILTER

Page01-0001

Item	Part Number	Qty	Description Comments	Technical Specification
	72629564	1	VENTILATION FILTER OIL FILLING SOCKET SEE PAGE 14-0005 FROM MACHINE S/N 530/1285	HYDRAULIK

FENDT 1050 S4 (530/00101-05000) (WAM530XXX00F05001-99999)
12937280-M-1

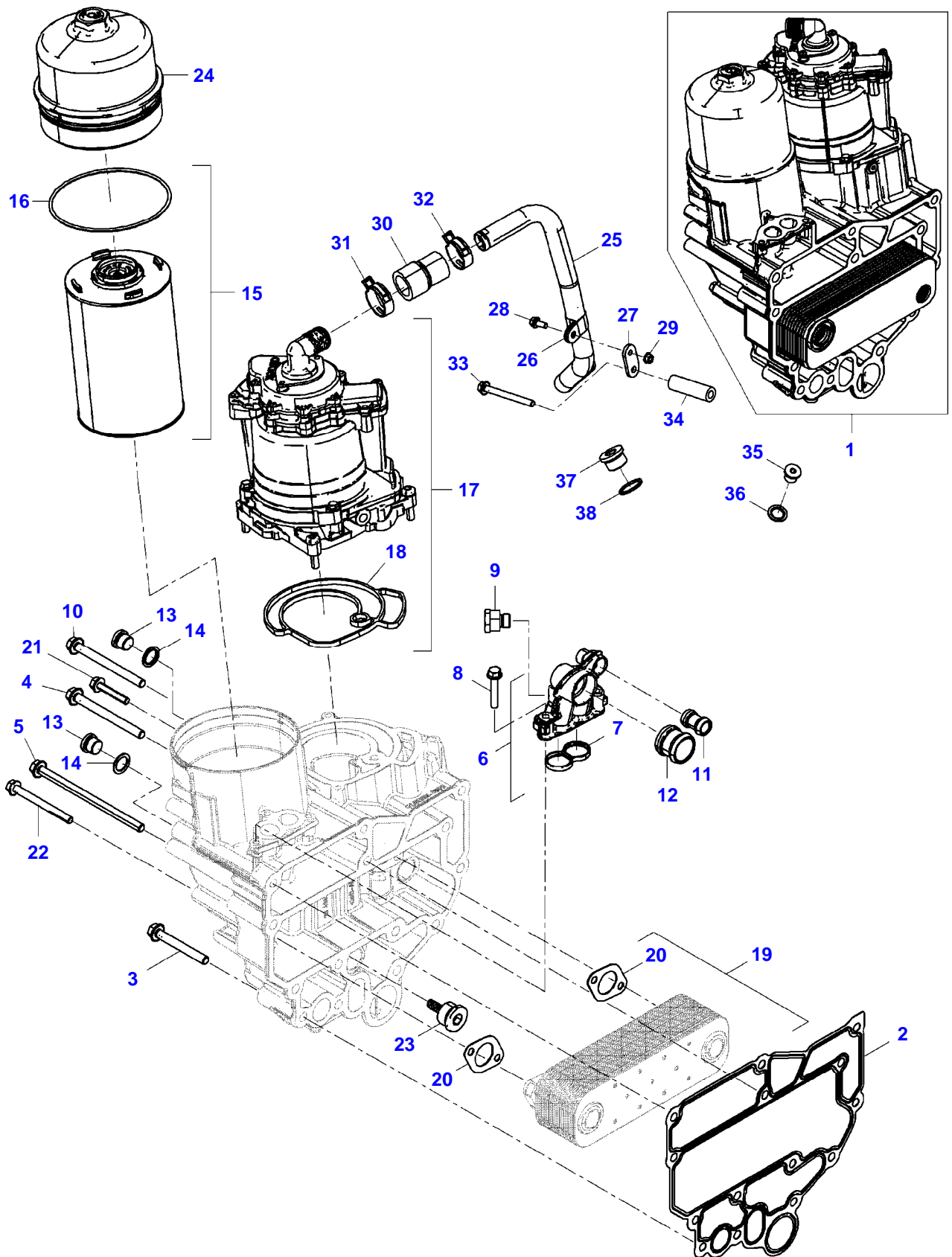

23235644-M-1

Item	Part Number	Qty	Description Comments	Technical Specification
1	ACP0300530	1	OIL MODULE ASSEMBLY INCLUDES ITEMS 15-24	
2	ACP0411280	1	GASKET	
3	72624244	8	HEX FLANGE CAPSCREW	M10X80-10.9
4	72627945	4	HEX FLANGE CAPSCREW	M10X160
5	72627915	2	HEX FLANGE CAPSCREW	
6	ACP0353570	1	FLANGE INCLUDES ITEMS 7	
7			NOT AVAILABLE IN SINGLE PARTS	
8	72624663	3	HEX FLANGE CAPSCREW	M8X45-10.9
9	72657407	1	SCREW NECK	M16X1,5/M18X1,5
10	72627945	1	HEX FLANGE CAPSCREW	M10X160
11	72624609	1	EXTENSION TUBE	
12	72624610	1	EXTENSION TUBE	
13	72629226	2	PLUG SCREW	
14	72623466	2	SEALING WASHER	PCS-18,3X26-ST/FKM1-80
15	ACP0154860	1	FILTER CARTRIDGE INCLUDES ITEMS 16	
16	72624577	1	O-RING SEAL	126X4
17	ACP0300540	1	OIL SEPARATOR INCLUDES ITEMS 18	
18	72627918	1	GASKET	
19	72627919	1	OIL COOLER INCLUDES ITEMS 20	
20	72627920	2	OIL COOLER SEAL	
21	72624219	2	HEX FLANGE CAPSCREW	M8X45-8.8
22	72624220	2	HEX FLANGE CAPSCREW	M8X90-8.8
23	72624396	1	PRESSURE-RELIEF VALVE	
24	72624398	1	LID	
25	72624343	1	BREATHING LINE INCLUDES ITEMS 26-29	
26	72624317	1	BRACKET CLAMP	A1-22X20-W4
27	72624492	1	HOLDER	
28	72624207	1	HEXAGONAL HEAD BOLT	M8X20-10.9
29	72624274	1	HEX NUT	M8-8
30	72624572	1	HOSE	
31	72605607	1	CLIP	
32	72608303	1	CLIP	
33	72624245	1	HEX FLANGE CAPSCREW	M10X100-10.9
34	72649480	1	BUSHING	12,5X24X80
35	72629224	1	PLUG SCREW	
36	72624303	1	SEALING WASHER	14,3X22X1,5-ST/FKM1-80
37	72624273	1	PLUG SCREW	M24X1,5-ST-M3360-RK12-K
38	72624296	1	SEALING WASHER	A24X29-CU

FENDT 1050 S4 (530/00101-05000) (WAM530XXX00F05001-99999)
 12940285-M-1

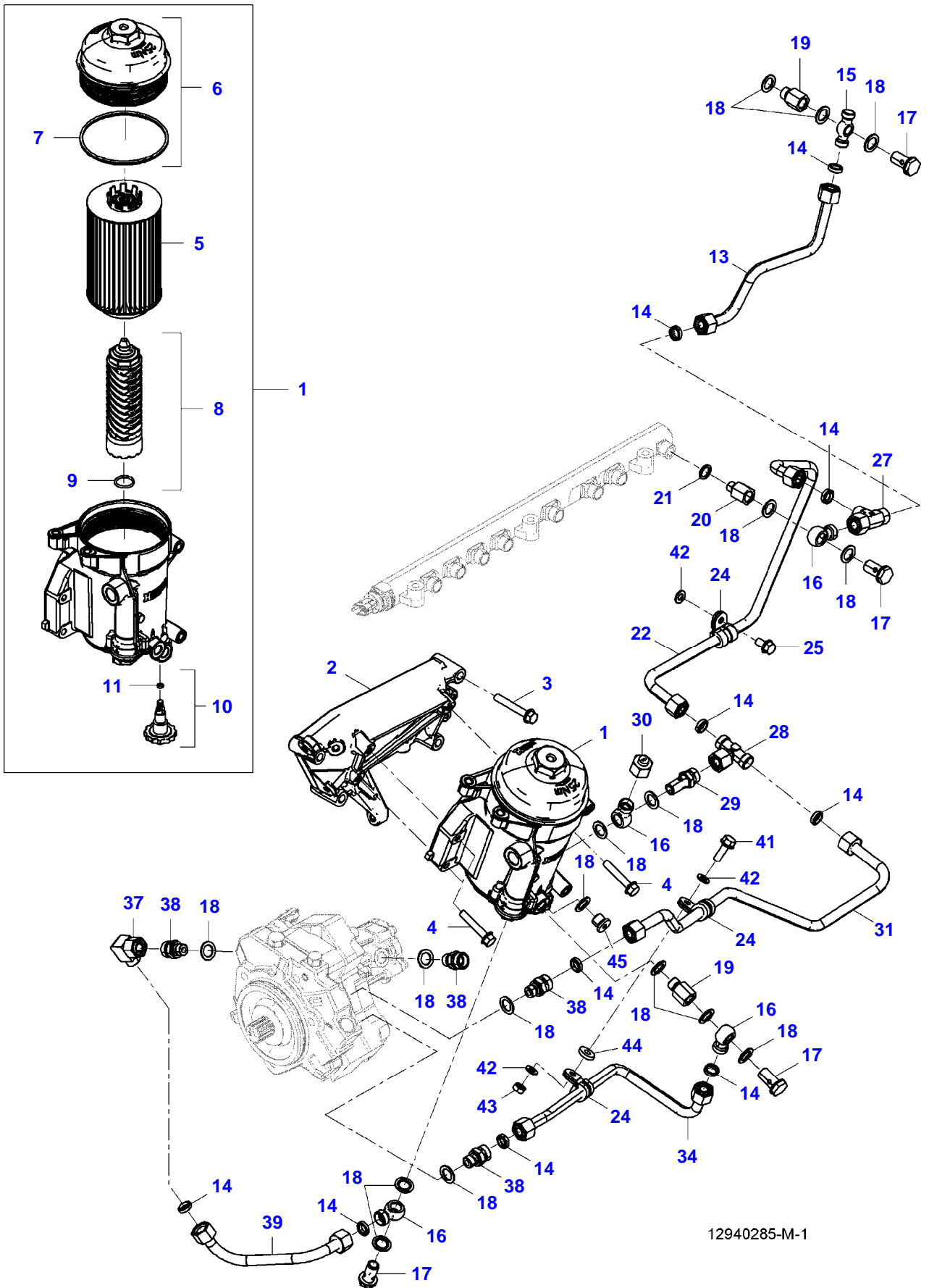

12940285-M-1

FUEL FILTERS

Item	Part Number	Qty	Description Comments	Technical Specification
1	72624483	1	FUEL FILTER INCLUDES ITEMS 5-11	
2	72624488	1	HOLDER	
3	72624235	4	HEX FLANGE CAPSCREW	M8X55-10.9
4	72624663	3	HEX FLANGE CAPSCREW	M8X45-10.9
5	ACP0410280	1	FILTER ELEMENT	
6	72624485	1	LID INCLUDES ITEMS 7	
7	72624574	1	O-RING SEAL	100X4-HNBR-60
8	72624484	1	SUPPORT PIPE INCLUDES ITEMS 9	
9	72624298	1	O-RING SEAL	18X2,5B-FKM1-70-GN
10	72624542	1	DRAIN PLUG INCLUDES ITEMS 11	
11	72624575	1	O-RING SEAL	4,5X2-FPM
13	72624482	1	FUEL LINE INCLUDES ITEMS 14	12X1,5
14	72624576	10	SEALING WASHER	E02-12L-ST-VITON
15	72624593	1	BANJO UNION	
16	72346246	4	RING FITTING	
17	72417155	4	BANJO BOLT	
18	72624303	17	SEALING WASHER	14,3X22X1,5-ST/FKM1-80
19	72316290	2	NOZZLE	
20	72624600	1	REDUCING STUD	M12X1,5/M14X1,5
21	72624302	1	SEALING WASHER	12,3X18X1,5-ST/FKM1-80
22	72624481	1	FUEL LINE INCLUDES ITEMS 23,24	12X1,5
24	72608293	3	CLIP	
25	72624230	1	HEX FLANGE CAPSCREW	M8X20-10.9
27	72624324	1	DIVIDER UNION	L12-NBR
28	72624596	1	T-FITTING	L12
29	72624604	1	BANJO BOLT	
30	72624543	1	LOCKING PLUG	M18X1,5
31	72624480	1	FUEL LINE INCLUDES ITEMS 32,33	12X1,5
34	72624479	1	FUEL LINE INCLUDES ITEMS 35,36	12X1,5
37	72624597	1	SOCKET	L12-ST
38	72624598	4	SOCKET	L12M14X1,5-ST
39	72624478	1	FUEL LINE INCLUDES ITEMS 40	
41	72624231	1	HEX FLANGE CAPSCREW	M8X25-10.9
42	72649375	3	WASHER	8X16X1,6-200HV
43	72624274	1	HEX NUT	M8-8
44	72624549	1	WASHER	8,4X20X4-9SMNPB28K
45	72624271	1	PLUG SCREW	M14X1,5-ST-M3360-RK10-K

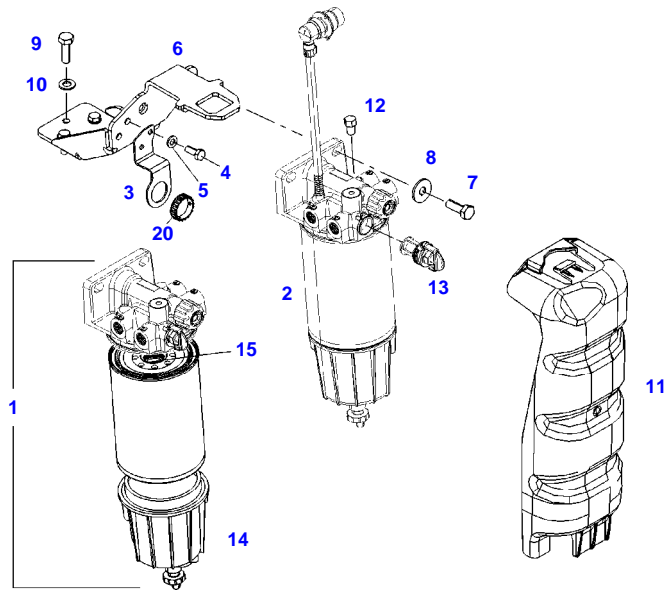

F061570



Item	Part Number	Qty	Description Comments	Technical Specification
1	72623758	1	FUEL PREFILTER INCLUDES ITEMS 12-15	
2	72623759	1	FUEL PREFILTER HEATED INCLUDES ITEMS 12-15	
3	72619544	1	ANGLE	
4	72315626	2	HEXAGONAL HEAD BOLT	DIN 933-M6 X 16-8.8-A3L
5	72311787	2	DISC	DIN 125-6,4-ST.A3L
6	72623755	1	HOLDER UP TO MACHINE S/N WAM530XXX00F05549	
	72655509	1	HOLDER FROM MACHINE S/N WAM530XXX00F05550	
7	72315685	2	HEXAGONAL HEAD BOLT	DIN 933 M10X30-8.8A3L
8	72311827	2	DISC	DIN9021-10,5-140HV-A3L
9	72315653	3	HEXAGONAL HEAD BOLT	DIN 933 M8 X 25-8.8A3L
10	72311788	3	DISC	DIN 125-8,4-ST.A3L
11	72600654	1	COVERING	
12	72470047	1	BLEED SCREW	
13	72610620	1	THERMOSTATIC VALVE	
14	72440017	1	CONTAINER B091	
15	72614253	1	FILTER ELEMENT	
20	72485325	1	MOUNTING RING	

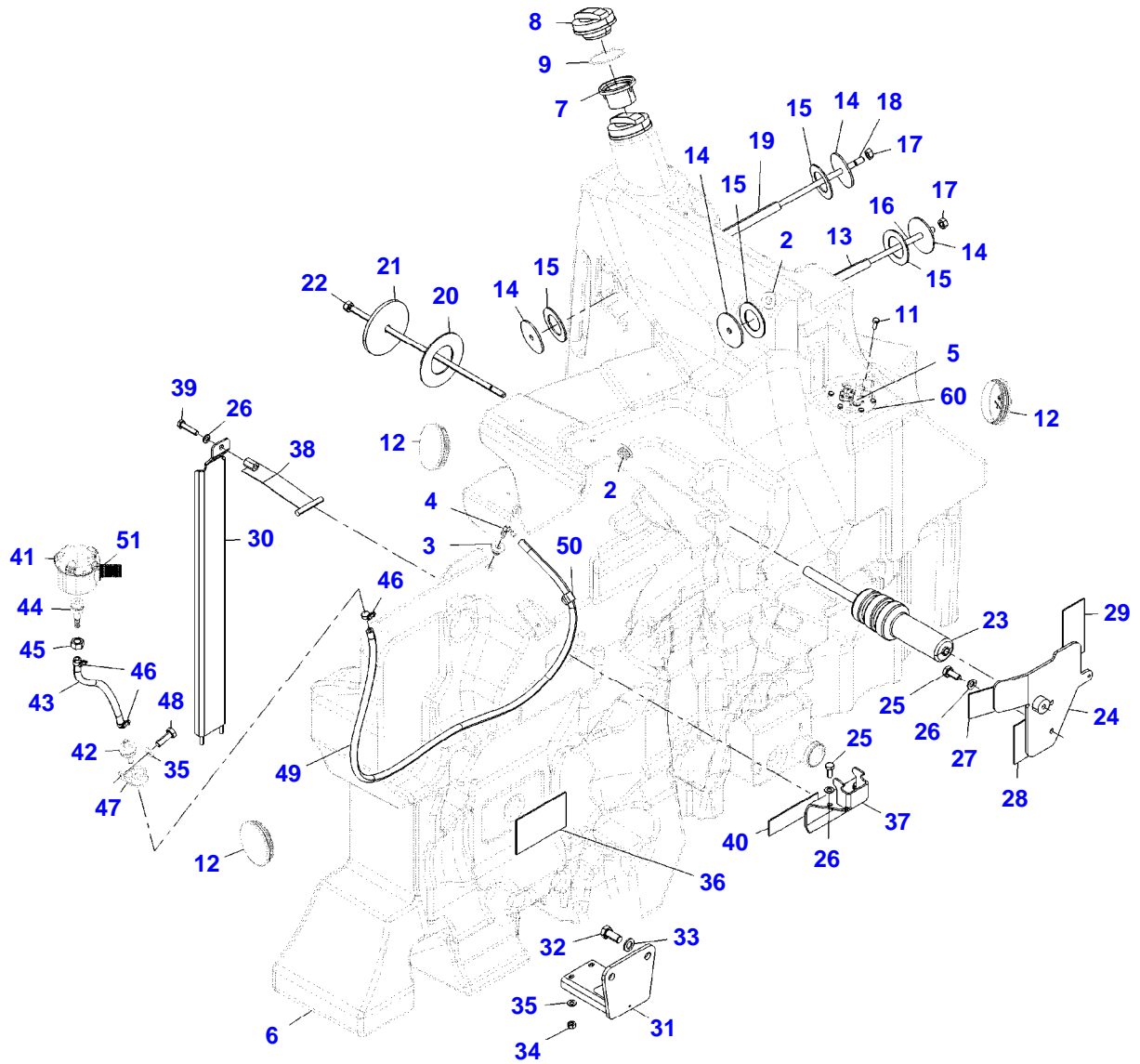

13071451-M-1

Item	Part Number	Qty	Description Comments	Technical Specification
2	72619547	2	GROMMET	
3	72441345	1	SPOUT	
4	72478216	1	REDUCING ELBOW HOSE CONNECTION	
5	72623754	1	FUEL TRANSMITTER	
6	72649570	1	FUEL TANK INCLUDES ITEMS 7-10	LI
7	72419182	1	THREADED INSERT	
8	72417260	1	FUEL CAP	
	72423400	1	FUEL CAP LOCKABLE	
9	72452730	1	O-RING	75X4-70 FPM 173104 FWN56402
11	ACW0775760	6	HEXAGON FLANGE BOLT	EN1665 M6X1X16-8 VDA30
12	72441667	3	LOCKING PLUG	GL102
13	72619549	1	SPACER TUBE	
14	72619542	4	DISC	
15	72619543	4	FELT DISC	
16	72624173	1	THREAD BOLT	
17	72313276	2	NUT	DIN 934 M12-8A3L
18	72624172	1	THREAD BOLT	
19	72619551	1	SPACER TUBE	
20	72437083	1	FELT WASHER	
21	72437598	1	DISC	
22	72624171	1	THREAD BOLT	
23	72631198	1	HOLDER	
24	72623756	1	HOLDER	
25	72315681	5	HEXAGONAL HEAD BOLT	DIN 933 M10X25-8.8A3L
26	72311789	6	DISC	DIN 125-10,5-ST.A3L
27	72619019	1	FELT STRIP	3X65X84_FWN63024
28	72619015	1	FELT STRIP	3X55X100_FWN63024
29	72619020	1	FELT STRIP	3X65X140_FWN63024
30	72620338	1	STAY	
31	72620333	1	TANK SUPPORT	
32	72315732	2	HEXAGONAL HEAD BOLT	DIN 933 M16X35-8.8A3L
33	72311793	2	DISC	DIN 125-17-ST.A3L
34	72313268	2	NUT	DIN 934 M8-8A3L
35	72311788	3	DISC	DIN 125-8,4-ST.A3L
36	72619026	1	FELT STRIP	3X90X150_FWN63024
37	72619548	1	SHEET METAL	
38	72620337	1	BAND CLAMP	
39	72315693	1	HEXAGONAL HEAD BOLT	DIN 933 M10X45-8.8A3L
40	72619013	1	FELT STRIP	3X40X150_FWN63024
41	72623748	1	AIR FILTER INCLUDES ITEMS 51	
42	4351598M1	1	NON RETURN VALVE	
43	72486217	1	PRESSURE HOSE CUT TO LENGTH L=250MM	L=0,280
44	72623753	1	UNION	
45	72313286	1	NUT	DIN 934 M16X1,5-8A3L
46	72438345	3	HOSE CLIP	
47	72311252	1	PIPE CLAMP	
48	72315653	1	HEXAGONAL HEAD BOLT	DIN 933 M8 X 25-8.8A3L
49	72420605	1	PRESSURE HOSE CUT TO LENGTH L=1650 MM	L=1750 E9X3 FWN 66041
50	72418527	1	CLIP	WELLROHR
51	ACP0225000	1	FILTER ELEMENT	
60	72643192	1	FLANGE WASHER	

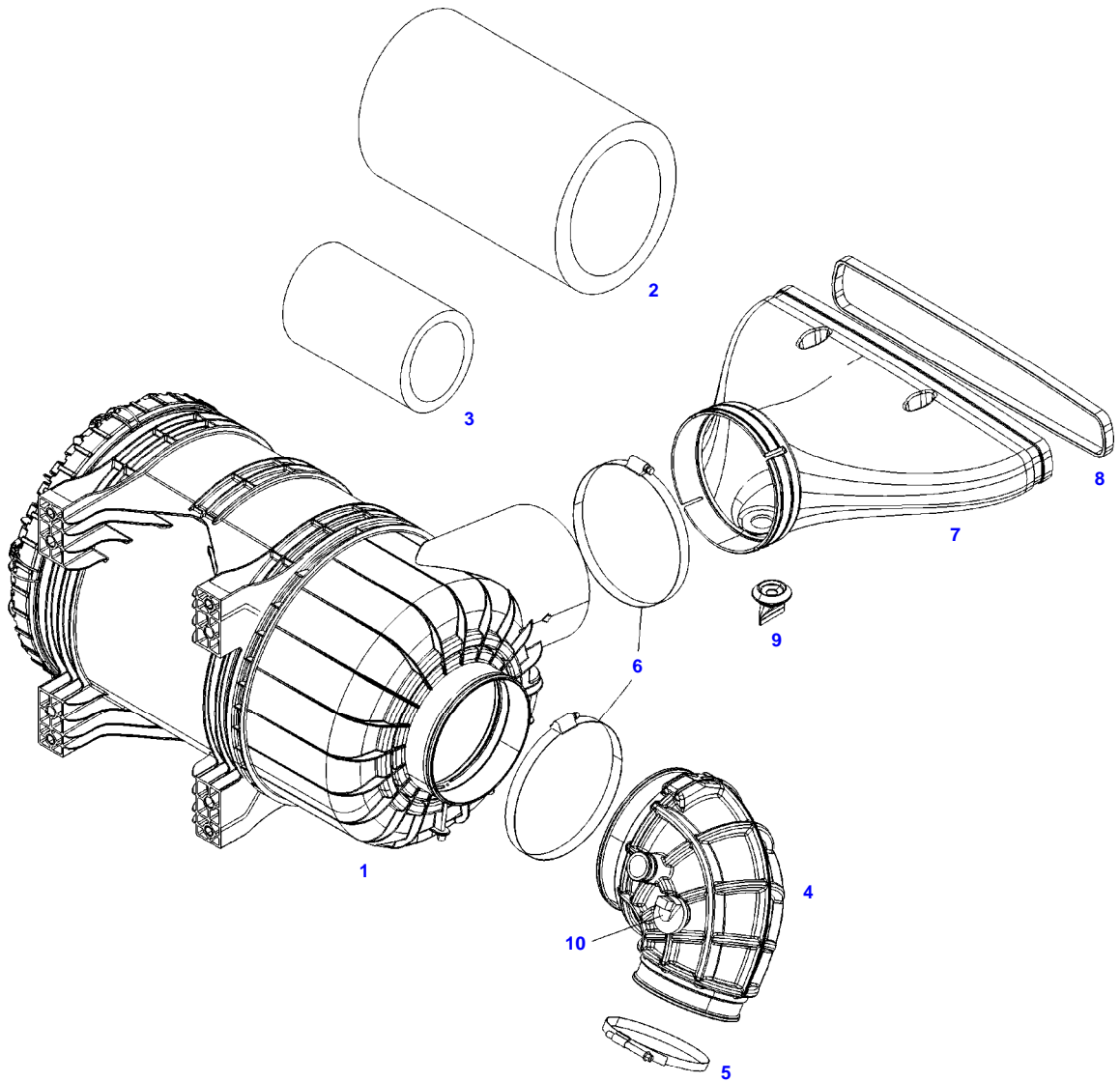

F061214



AIR FILTER

Item	Part Number	Qty	Description Comments	Technical Specification
1	72620063	1	AIR FILTER INCLUDES ITEMS 2,3	
2	72622474	1	PRIMARY AIR FILTER ELEMENT	
3	72622475	1	SECONDARY AIR FILTER ELEMENT	
4	72620064	1	AIR INTAKE HOSE	
5	72311175	1	HOSE CLIP	
6	72493427	2	HOSE CLIP	180-200
7	72619556	1	UNTREATED AIR CHANNEL	
8	72621056	1	SEALING STRIP	15X10_L=1,080M
9	72619754	1	SPOUT	
10	72626286	1	MAINTENANCE SWITCH B215	

FENDT 1050 S4 (530/00101-05000) (WAM530XXX00F05001-99999)
13051389-M-2

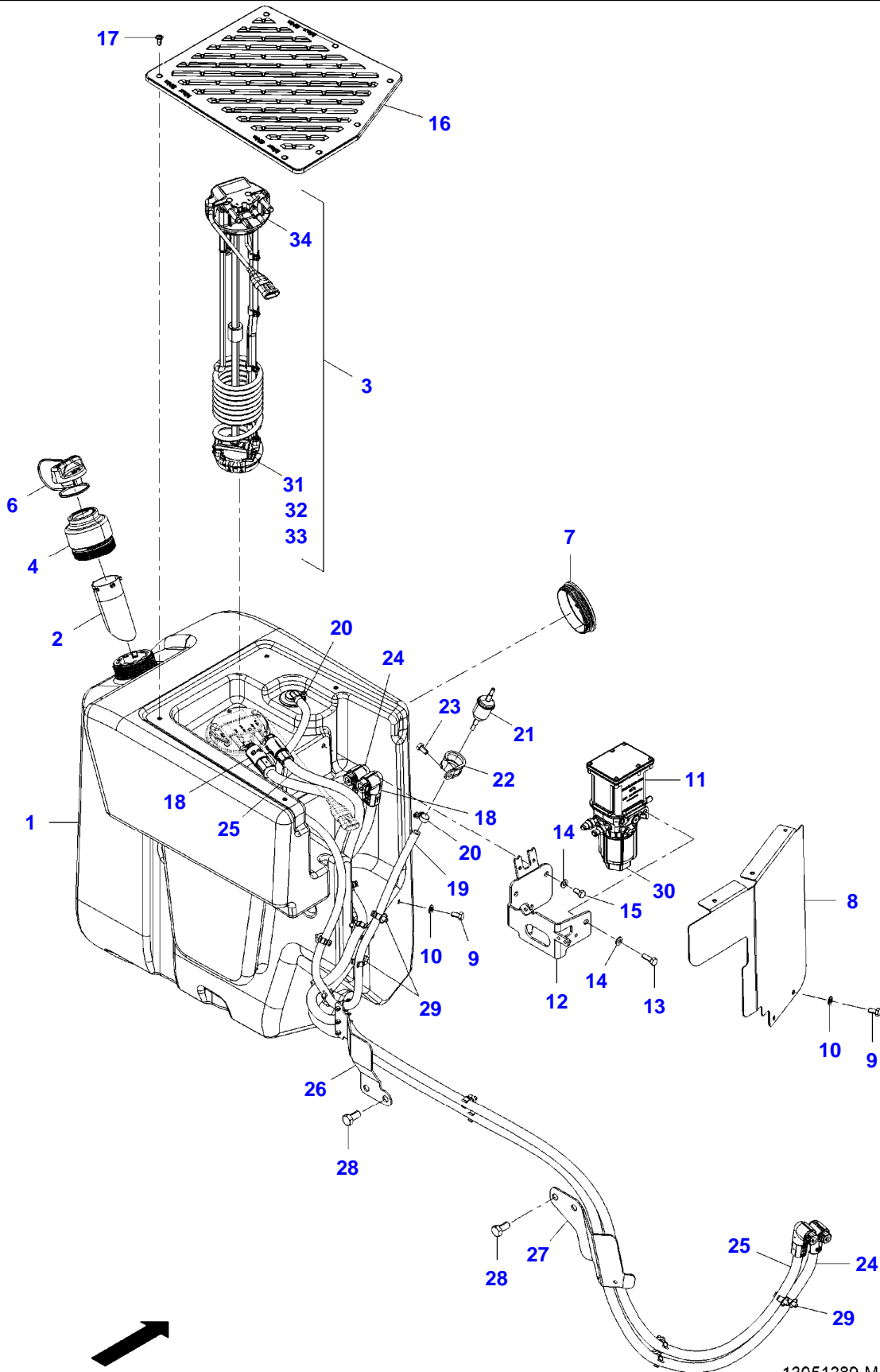

13051389-M-2

Item	Part Number	Qty	Description Comments	Technical Specification
			PIPING UP TO MACHINE S/N WAM530XXX00F05545	
1	72618761	1	DEF TANK	ADBLUE
2	72619577	1	TUBE	
3	72652666	1	DEF SENSOR B195 INCLUDES ITEMS 31-34	
4	72620072	1	FILLER	
6	72489115	1	FUEL CAP LOCKABLE	
	72489117	1	FUEL CAP	
7	72441667	1	LOCKING PLUG	GL102
8	72620362	1	COVER PANEL	
9	72315642	2	HEXAGONAL HEAD BOLT	DIN 933 M8 X 16-8.8A3L
10	72311788	2	DISC	DIN 125-8,4-ST.A3L
11	72620069	1	SUPPLY UNIT A155	DEF
12	72624060	1	HOLDER	
13	72315653	2	HEXAGONAL HEAD BOLT	DIN 933 M8 X 25-8.8A3L
14	72311788	4	DISC	DIN 125-8,4-ST.A3L
15	72315642	2	HEXAGONAL HEAD BOLT	DIN 933 M8 X 16-8.8A3L
16	72620363	1	COVER PANEL WITHOUT FIRE EXTINGUISHER	
17	72441737	7	OVAL HEAD SCREW	WN7381-M6X16-A2 NIRO
18	72620386	1	HOSE LINE	
19	72486267	1	PRESSURE HOSE CUT TO LENGTH L=1,285 MM	L=1,350
20	72438345	2	HOSE CLIP	
21	72484191	1	FILTER	
22	72311252	1	PIPE CLAMP	
23	72315642	1	HEXAGONAL HEAD BOLT	DIN 933 M8 X 16-8.8A3L
24	72624168	1	HOSE LINE	
25	72624169	1	HOSE LINE	
26	72619592	1	HOLDER	
27	72624167	1	HOLDER	
28	72315706	1	HEXAGONAL HEAD BOLT	DIN 933 M12X25-8.8A3L
29	72488959	22	CLIP	SCHLAUCH POM
30	ACP0153520	1	DEF FILTER	
31	ACP0338340	1	DEF FILTER	
32	ACP0338341	1	CLIP	
33	ACP0338342	2	O-RING	
34	ACP0338330	1	O-RING	102.5 X 5.9MM

FENDT 1050 S4 (530/00101-05000) (WAM530XXX00F05001-99999)
13541135-M-1

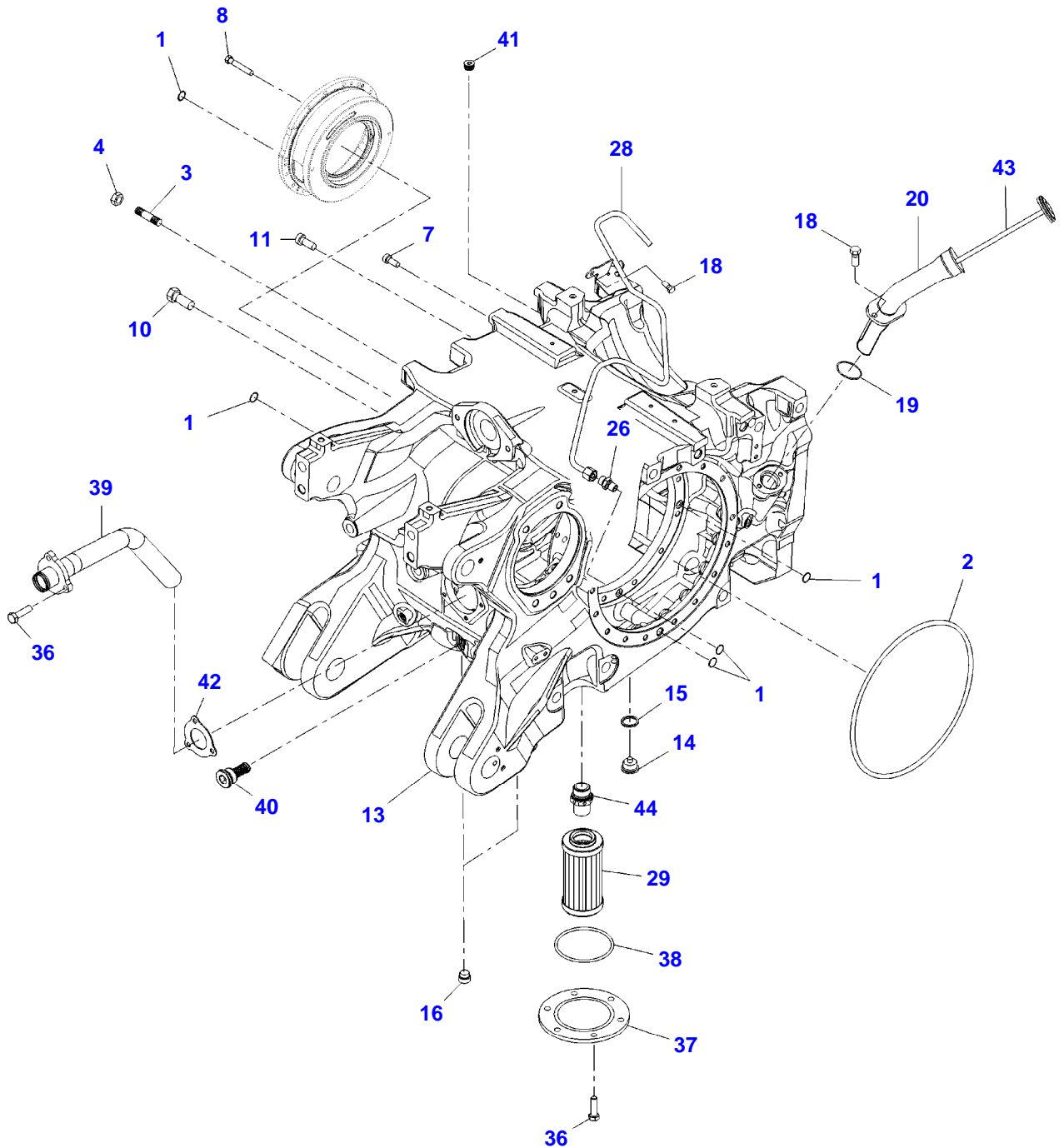

13541135-M-1

Item	Part Number	Qty	Description Comments	Technical Specification
			AXLE NR. 990/050 990/051 990/052 990/053	
1	72620893	5	O-RING	13,1X2,62
2	72620894	2	O-RING	329.79X3.53
3	72620895	2	STUD BOLT	
4	72620896	2	NUT	
7	72620897	3	SOCKET HEAD BOLT	M8X25
8	72617556	16	HEXAGONAL HEAD BOLT	M12X40
10	72620899	14	HEXAGONAL HEAD BOLT	
11	72620900	12	SOCKET HEAD BOLT	
13	72625855	1	HOUSING	
14	72428213	1	SCREW	M30X1,5
15	72376044	1	SEALING WASHER	DIN 7603 A30X38-CU
16	72621023	2	SCREW	M18X1,5
18	72620904	3	SCREW	M8X20
19	72313465	1	O-RING	34X3-FPM 70 FWN56402
20	72625857	1	OIL INFILL	
26	72620907	2	SCREW NECK	D8 M12 M14
28	72625856	1	LUBRICATION LINE	
29	72623924	1	FILTER	FILTEREINSATZ-VORDERACHSE
36	72315655	9	HEXAGONAL HEAD BOLT	DIN 933 M8X30-8.8
37	72625858	1	COVER	
38	72313494	1	O-RING	75,79X3,53-NBR 70-FWN56402
39	72625859	1	INTAKE	
40	72623929	1	CHECK VALVE	
41	72625860	1	SCREW	
42	72625861	1	SEAL	
43	72625880	1	DIPSTICK	
44	72625908	1	VALVE	

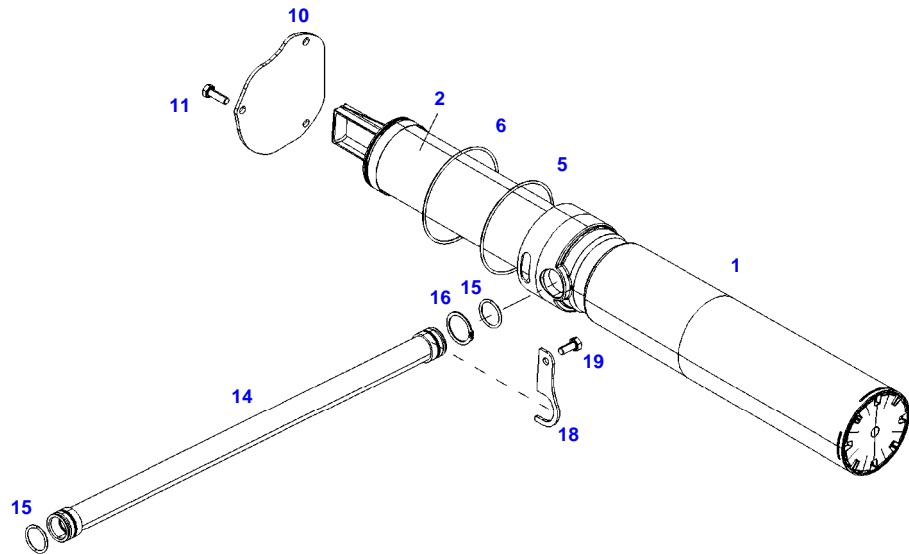

F060817



Item	Part Number	Qty	Description Comments	Technical Specification
1	72620045	1	SUCTION FILTER INCLUDES ITEMS 2	
2	72621035	1	FILTER ELEMENT	GETRIEBEOEL
5	72313503	1	O-RING	105X3-NBR 70 FWN56402
6	72424095	1	O-RING	108X3-NBR 70 FWN56402
10	72619443	1	FILTER LID	
11	72315653	3	HEXAGONAL HEAD BOLT	DIN 933 M8 X 25-8.8A3L
14	72620282	1	SUCTION PIPE	
15	72313458	2	O-RING	27X3-FPM 80 FWN56402
16	72311064	1	LOCK WASHER	DIN 471-32X1,5
18	72619444	1	RETAINING SHEET METAL	
19	72315648	1	HEXAGONAL HEAD BOLT	DIN 933 M8X20-8.8

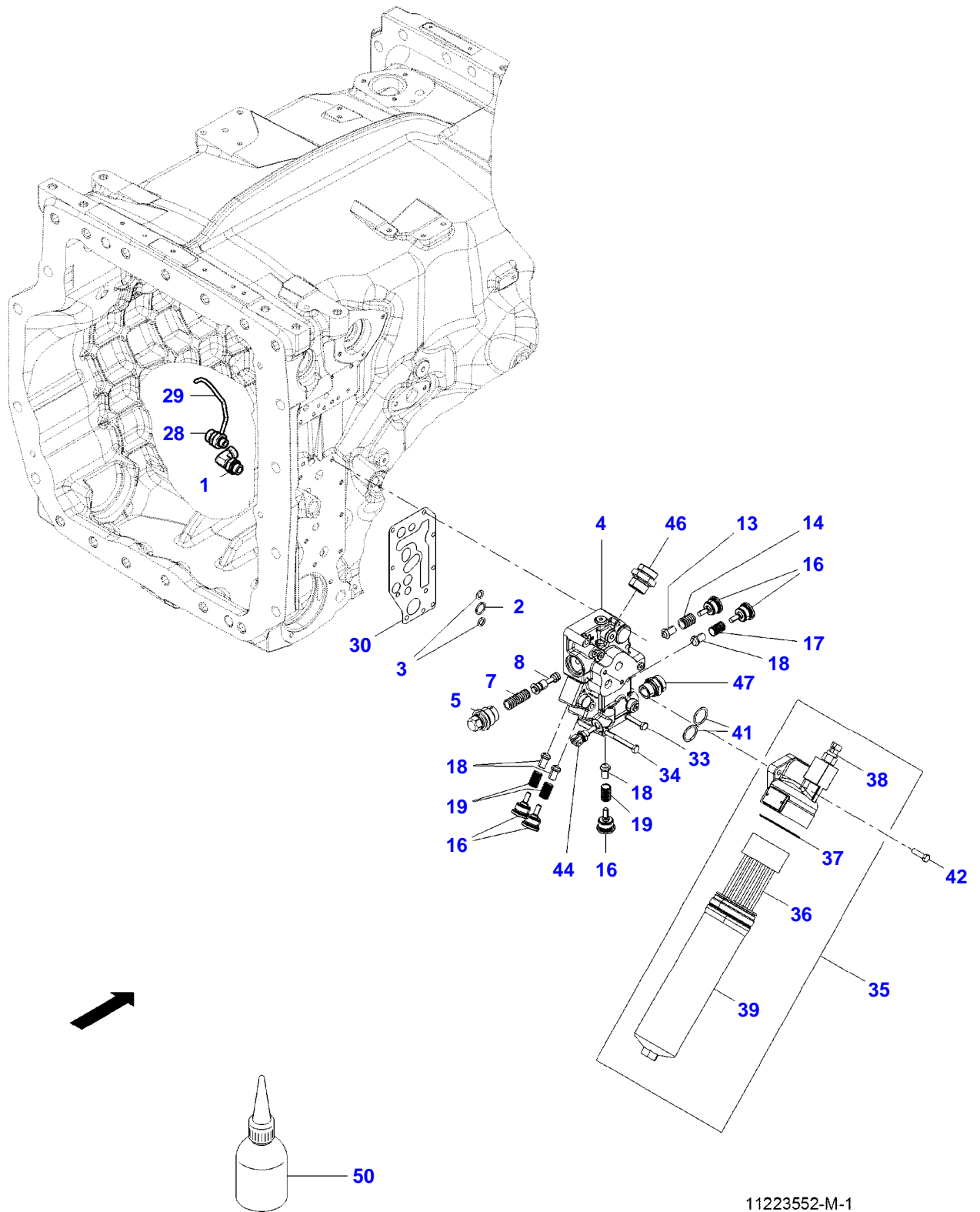

11223552-M-1

Item	Part Number	Qty	Description Comments	Technical Specification
PRESSURE FILTER				
1	72439931	1	ANGULAR THREADED CONNECTION	
2	72313441	1	O-RING	18,72X2,62-NBR 70 FWN56402
3	72313421	2	O-RING	11X3-FPM 80 FWN56402
4	72623535	1	VALVE BLOCK INCLUDES ITEMS 5-19	
	72453370	1	SEAL KIT	
	72312345	1	SEAL	
5	72623536	1	SLEEVE	
7	72316537	1	COMPRESSION SPRING	
8	72441065	1	PISTON	
13	72437531	1	SEALING CONE	
14	72437333	1	COMPRESSION SPRING	
16	72315891	5	SCREW	
17	72316522	1	COMPRESSION SPRING	
18	72311280	4	SEALING CONE	
19	72316539	3	COMPRESSION SPRING	
28	72630140	1	SCREW NECK	
29	72629287	1	LUBRICATING OIL PIPE	
30	72312345	1	SEAL	
33	72315531	7	HEXAGONAL HEAD BOLT	DIN 931 M8 X 60-8.8
34	72315534	1	HEXAGONAL HEAD BOLT	DIN 931 M8 X 70-8.8
35	72617845	1	FILTER INCLUDES ITEMS 36-39	
36	72488569	1	FILTER ELEMENT	
37	72313495	1	O-RING	76X2,5-NBR 70 FWN56402
38			SEE PAGE 07-0014	
39	72485115	1	FILTER HOUSING	
41	72313459	2	O-RING	28X3-NBR 70 FWN56402
42	72315655	2	HEXAGONAL HEAD BOLT	DIN 933 M8X30-8.8
44			SEE ELECTRICAL SYSTEM TRANSMITTER	
46	72316329	1	SCREW NECK	DIN 3901-L28B-M-ST-A3
47	72612237	1	SCREW NECK	DIN3901-L22-M26X1,5-ED
50	72452254	1	THREADLOCKER	LOCTITE 274 10ML

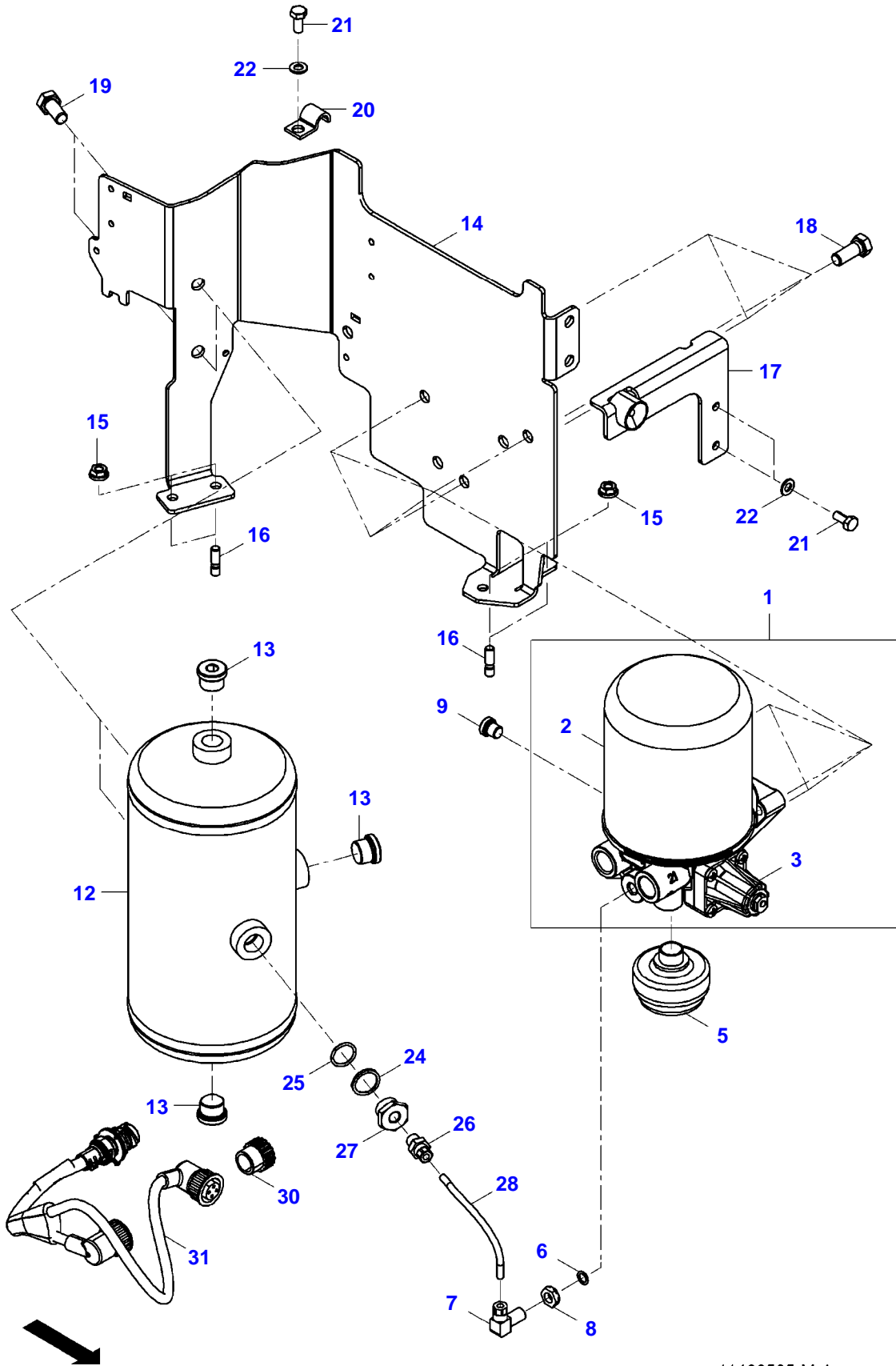

11439535-M-1

Item	Part Number	Qty	Description Comments	Technical Specification
1	72620231	1	AIR DRIER INCLUDES ITEMS 2,3	
2	72437515	1	CARTRIDGE JET	LUFTTROCKNER
3	72455949	1	HEATER	
5	72455889	1	NOISE DAMPER	
6	72313416	1	O-RING	9X2-NBR 70-FWN56402
7	72316989	1	W-E THREADED CONNECTION	STEVBD 6MM
8	72313360	1	SEALING NUT	M12X1,5
9	72315449	1	PLUG SCREW	FWN64838-M12X1,5-ED-FPM
12	72437464	1	AIR TANK	
13	72317613	3	PLUG SCREW	VSTIM22X1,5EDFPA3C
14	72628281	1	HOLDER	
15	72498942	4	HEX NUT	DIN EN1661-M8-8
16	72313770	4	STUD BOLT	FWN64891-M8X20-8.8
17	72625165	1	HOLDER	
18	72476613	3	HEXAGONAL HEAD BOLT	DIN 961 M12X1,5X30-8.8
19	72315706	2	HEXAGONAL HEAD BOLT	DIN 933 M12X25-8.8A3L
20	72387377	1	PIPE CLAMP	
21	72315646	3	HEXAGONAL HEAD BOLT	DIN 933 M8X18-8.8A3L
22	72311788	3	DISC	DIN 125-8,4-ST.A3L
24	72311209	1	THRUST RING	
25	72313445	1	O-RING	20,3X2,4-NBR 70 FWN56402
26	72316988	1	STRAIGHT THREADED CONNECTION	STEVBD
27	72316997	1	REDUCING SCREW CONNECTION	
28	72451279	1	PIPE 1X 150MM CUT TO LENGTH	L=2000MM DIN74324-6X1
30	72482655	1	ELECTRICAL CONNECTOR	
31	72611091	1	KIT, CABLE	

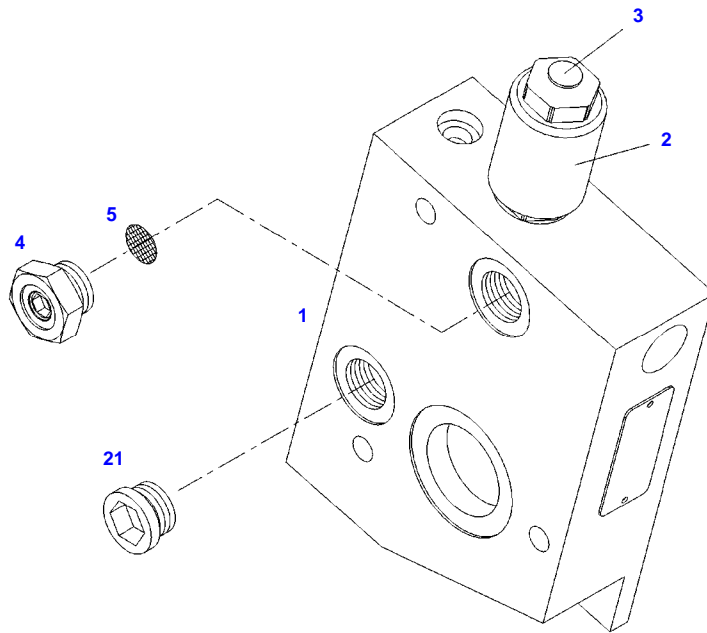

F060965



Item	Part Number	Qty	Description Comments	Technical Specification
			WITH POWER BEYOND CONNECTION	
1	72486753	1	END PLATE INCLUDES ITEMS 2-5	
2	72476782	1	MAGNET COIL	
3	72455766	1	VALVE	
	72489719	1	DUST PLUG SERVICE REPAIR SOLUTION	
4			NOT AVAILABLE IN SINGLE PARTS	
5	72470364	1	FILTER	
21	72315440	1	PLUG SCREW NOT USED AT POWER LIFT SINGLE ACTING	DIN 908 M18 X 1,5-ST

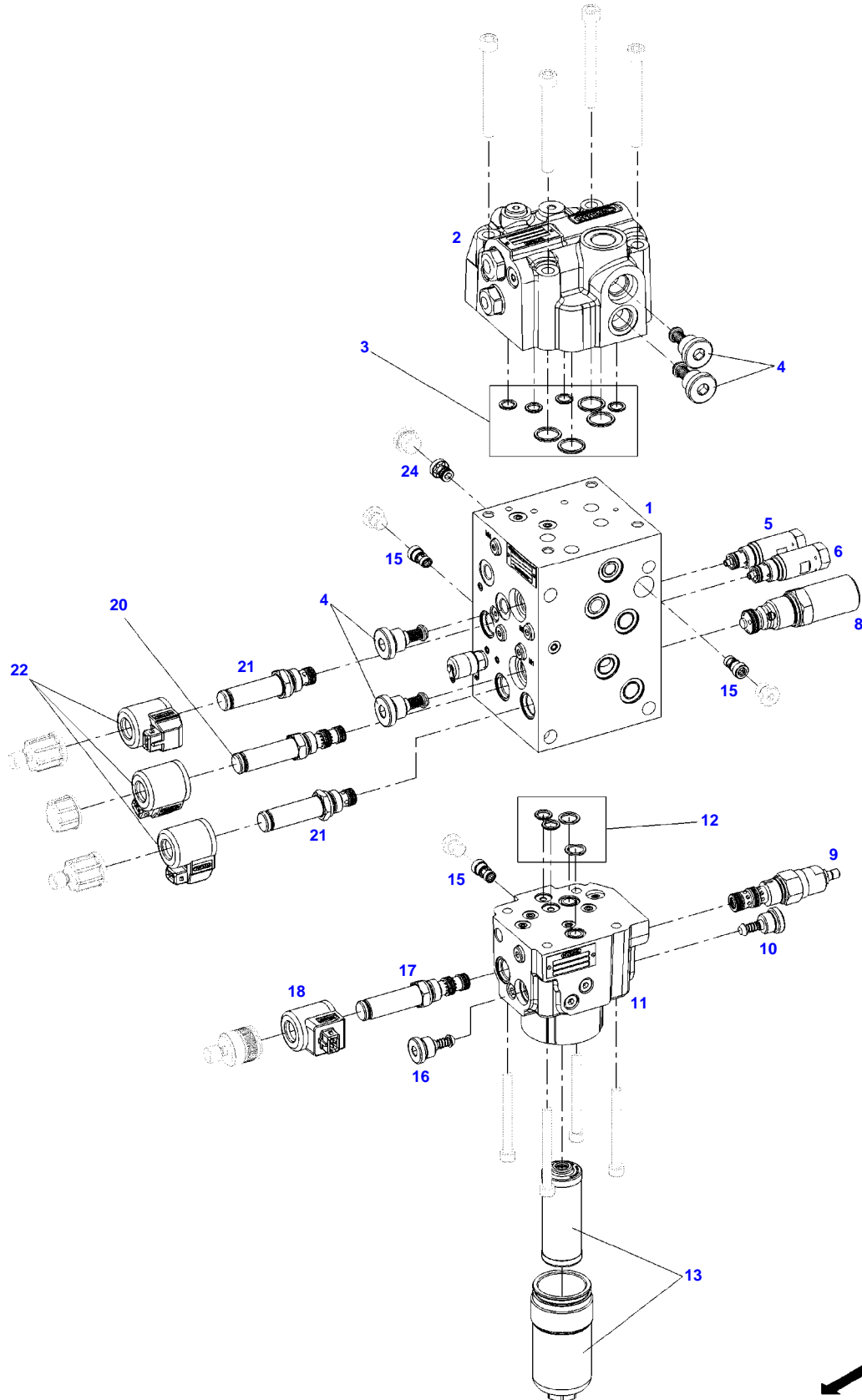

F061195



Item	Part Number	Qty	Description Comments	Technical Specification
			UP TO MACHINE S/N WAM530XXX00F05238	
1	72624023	1	VALVE BLOCK INCLUDES ITEMS 2-24	
2	72626279	1	PRESSURE MAINTENANCE VALVE	
3	72626280	1	SEAL KIT	
4	72476080	4	CHECK VALVE RVL1/2	
5	72455442	1	PRESSURE RELIEF VALVE DBVL	
	72317904	1	SEAL KIT DBVL	
6	72455496	1	PRESSURE RELIEF VALVE DBVF	
	72317904	1	SEAL KIT	
8	72317905	1	PRESSURE RELIEF VALVE DBV1	
	72317906	1	SEAL KIT	
9	72486199	1	PRESSURE CONTROL VALVE DRVP	
	72455011	1	SEAL KIT	
10	72476081	1	CHECK VALVE RVP1, NG10	
11	72626281	1	PRE-CONTROL UNIT KIT	
12	72626282	1	SEAL KIT	
13	72493246	1	HYDRAULIC FILTER	STEUERDRUCK
15	72317919	2	CHANGE VALVE WV1/5	
16	72476082	1	CHECK VALVE RV_DFP, NG10	
17	72455510	1	VALVE MVP	
	72438741	1	SEAL KIT	
18	72455511	1	MAGNET COIL	
20	72438731	1	VALVE MVL	
	72438741	1	SEAL KIT	
21	72486195	2	VALVE MVFH/MVFS	
	72438742	2	SEAL KIT	
22	72484293	3	MAGNET COIL	
24	72487209	1	CHECK VALVE RVF1	

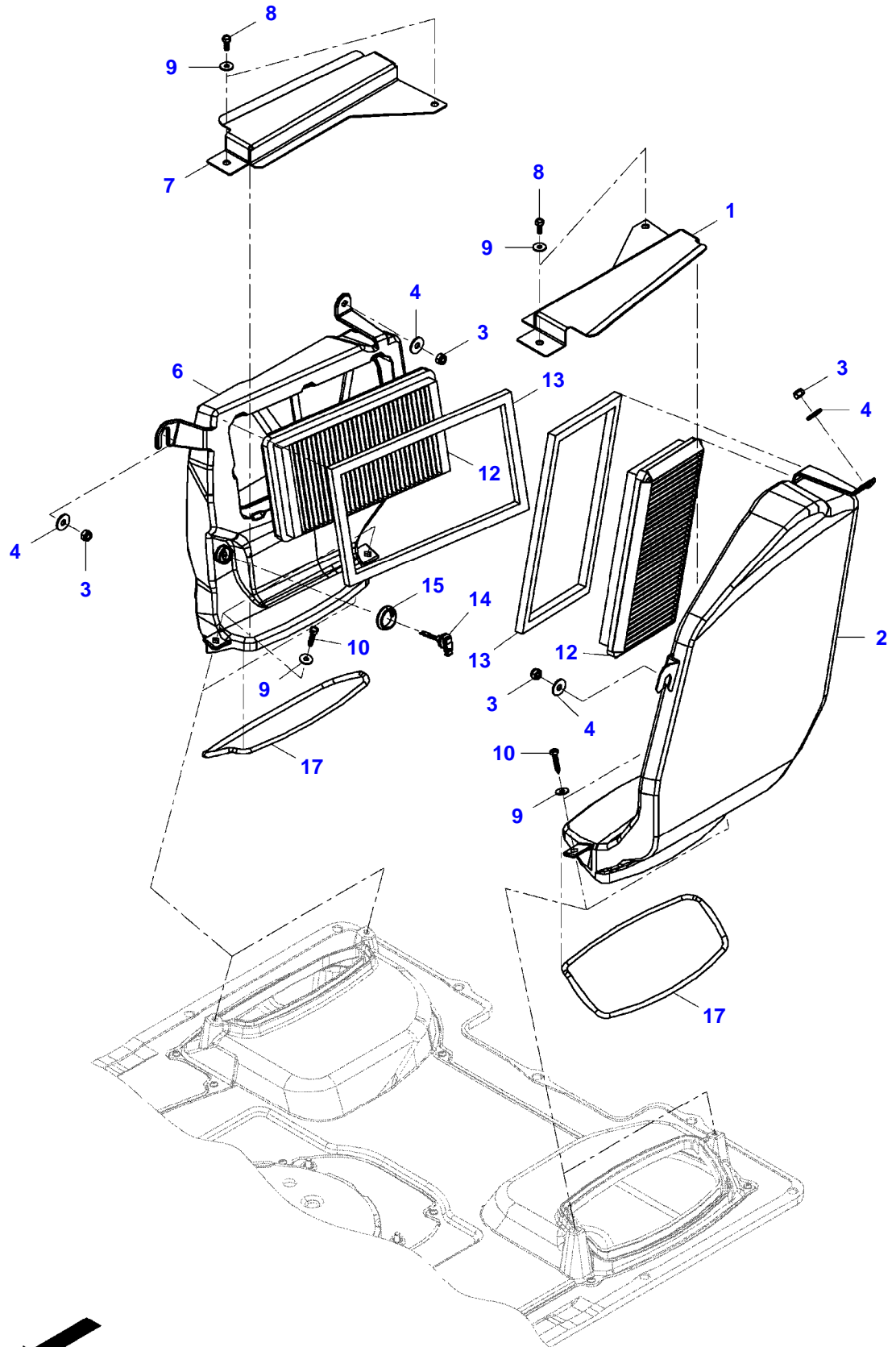

22871904-M-1

Item	Part Number	Qty	Description Comments	Technical Specification
1	72619770	1	COVER PANEL	
2	72619773	1	AIR FUNNEL	
3	72372950	4	NUT	DIN 985 M8-8A3L
4	72311824	4	DISC	DIN9021-8,4-140HV-A3L
6	72620538	1	AIR FUNNEL	
7	72619769	1	COVER PANEL	
8	72315815	4	SCREW	DIN7976-ST6,3X16-F-A3L
9	72311822	8	DISC	DIN9021-6,4-140HV-A3L
10	72424850	4	SCREW	DIN7976-ST6,3X32-C-A3L
12	72620539	2	FILTER CAB AIR RECIRCULATION	
13	72623408	2	GASKET	
14	72486861	1	SENSOR TEMPERATURE INSIDE	
15	72623219	1	GASKET	
17	72619759	2	GASKET	

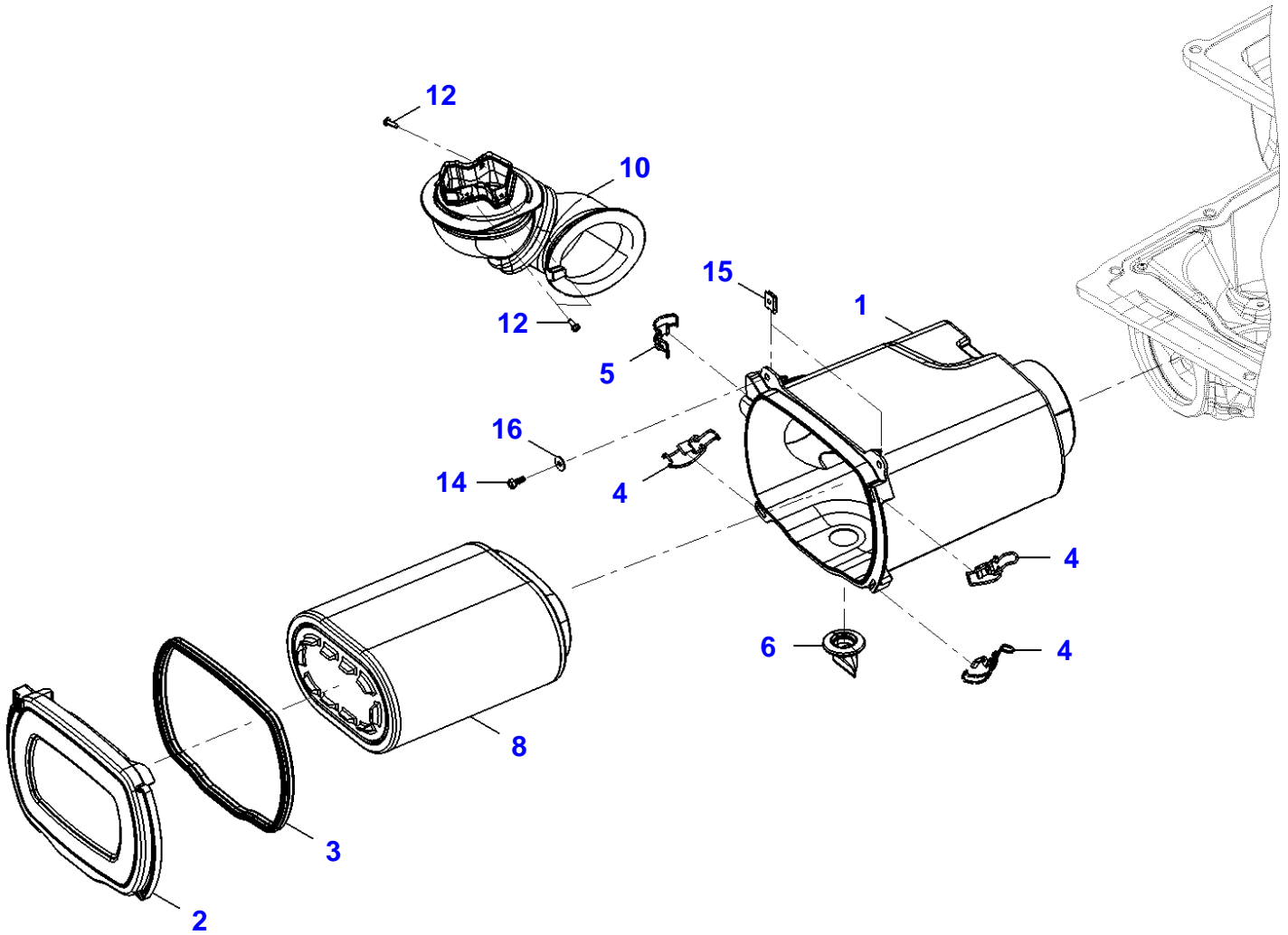

Item	Part Number	Qty	Description Comments	Technical Specification
1	72619775	1	HOUSING	
2	72619776	1	LID	
3	72621050	1	SEALING PROFILE 1X 765MM	L=1,970M-FWN63041_8
4	72620163	3	DRAW LATCH	
5	72620164	1	DRAW LATCH	
6	72490381	1	UNIVERSAL SPOUT	
8	72620540	1	FILTER CARTRIDGE	
10	72620156	1	RUBBER ARCH	
12	72455397	3	SCREW	F.BLECH ST4,8X16-F A3R
14	72315815	2	SCREW	DIN7976-ST6,3X16-F-A3L
15	72313338	2	SPEED NUT	6,3 MKB1
16	72311822	2	DISC	DIN9021-6,4-140HV-A3L

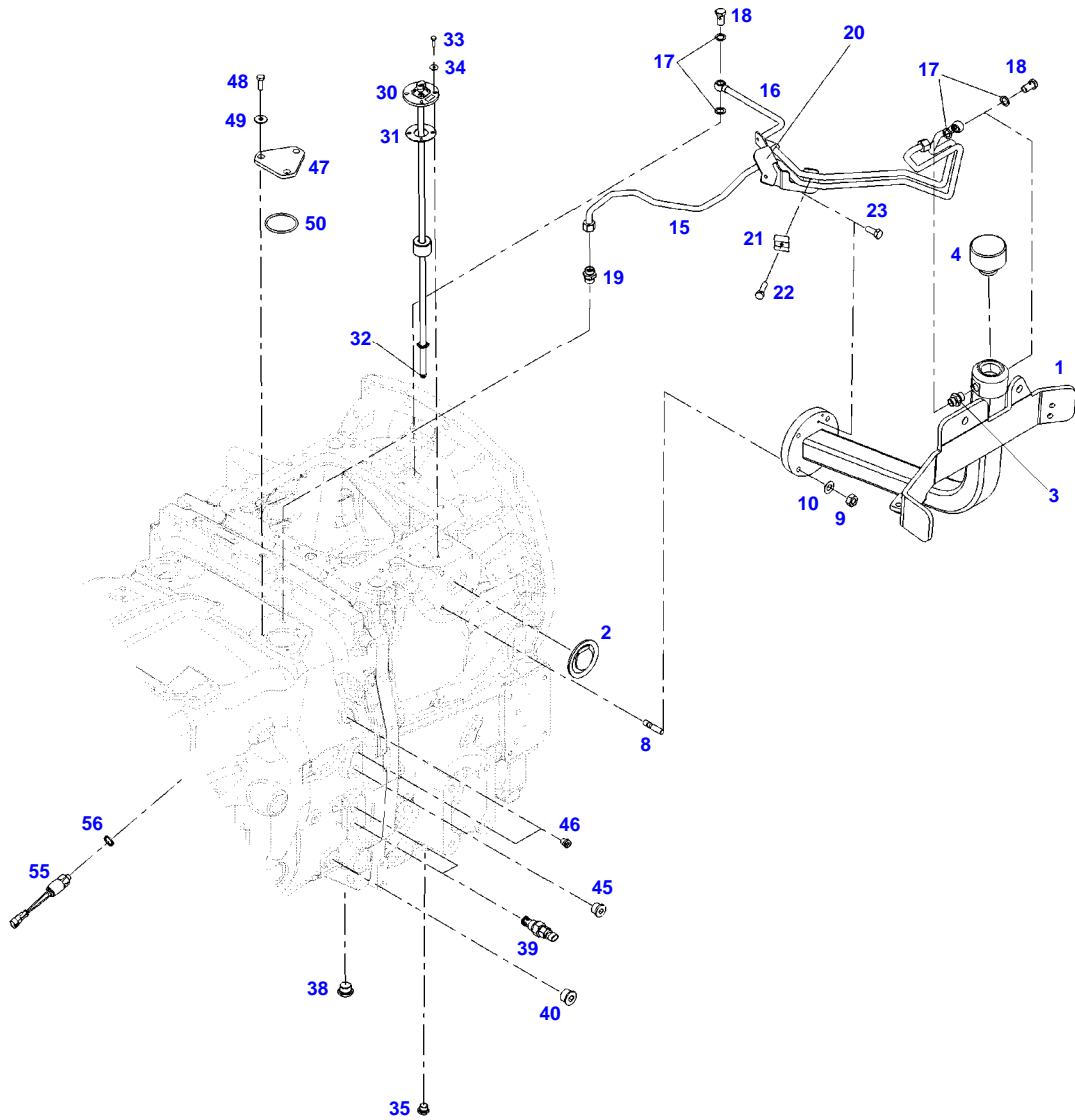

F061390



Item	Part Number	Qty	Description Comments	Technical Specification
			FROM - UP TO MACHINE S/N 530/1001 - 530/1284	
1	72629563	1	FILLER ORDER ADDITIONAL	
	72629564	1	VENTILATION FILTER	HYDRAULIK
	72629565	1	SIEVE	
2	72623729	1	SEALING RUBBER	
3	72438330	1	SCREW NECK	FWN65925-L12-M18X1,5OMD-A3L 1
4	72364577	1	VENTILATION FILTER L1.0807-31	
8	72313777	4	STUD BOLT	DIN 939 M10X35-8.8
9	72313272	4	NUT	DIN 934 M10-8A3L
10	72317122	4	SPRING WASHER	DIN 137 B10-MECH.VZK
15	72624024	1	VENT TUBE	
16	72623688	1	VENT TUBE	
17	72608905	4	GASKETS	14X22X1,5
18	72315808	2	BANJO BOLT	DIN 7643-10-3-A3L
19	72438330	1	SCREW NECK	FWN65925-L12-M18X1,5OMD-A3L 1
20	72623638	1	HOLDER	
21	72311266	1	CLIP	
22	72315633	1	HEXAGONAL HEAD BOLT	DIN 933 M6X25-8.8A3L
23	72315626	2	HEXAGONAL HEAD BOLT	DIN 933-M6 X 16-8.8-A3L
30	72623127	1	FUEL TRANSMITTER INCLUDES ITEMS 31,32	
31	72476833	1	FLANGE WASHER	
32	72451977	1	O-RING	D9X2,5
33	72315619	4	HEXAGONAL HEAD BOLT	DIN 933 M5X16-8.8A3L
34	72311819	4	DISC	DIN9021-5,3-140HV-A3R
35	72478716	1	PLUG SCREW	DIN 908 M16X1,5-ED-A3L
38	72438052	1	PLUG SCREW	
39	72618272	2	FLOWMETER	
40	72317613	1	PLUG SCREW NOT USED AT REAR POWER LIFT	VSTIM22X1,5EDFPA3C
45	72317613	1	PLUG SCREW	VSTIM22X1,5EDFPA3C
46	72315449	2	PLUG SCREW NOT USED AT 2ND CIRCUIT HYDR. 1 X	FWN64838-M12X1,5-ED-FPM
47	72629560	1	PLATE NOT USED AT 2ND CIRCUIT HYDR.	
48	72315653	3	HEXAGONAL HEAD BOLT NOT USED AT 2ND CIRCUIT HYDR.	DIN 933 M8 X 25-8.8A3L
49	72311824	3	DISC NOT USED AT 2ND CIRCUIT HYDR.	DIN9021-8,4-140HV-A3L
50	72437222	1	O-RING NOT USED AT 2ND CIRCUIT HYDR.	60X4-NBR 70 FWN56402
55	72453413	1	PRESSURE SWITCH	
56	72315090	1	SEALING WASHER	DIN 7603 A12X15,5-CU

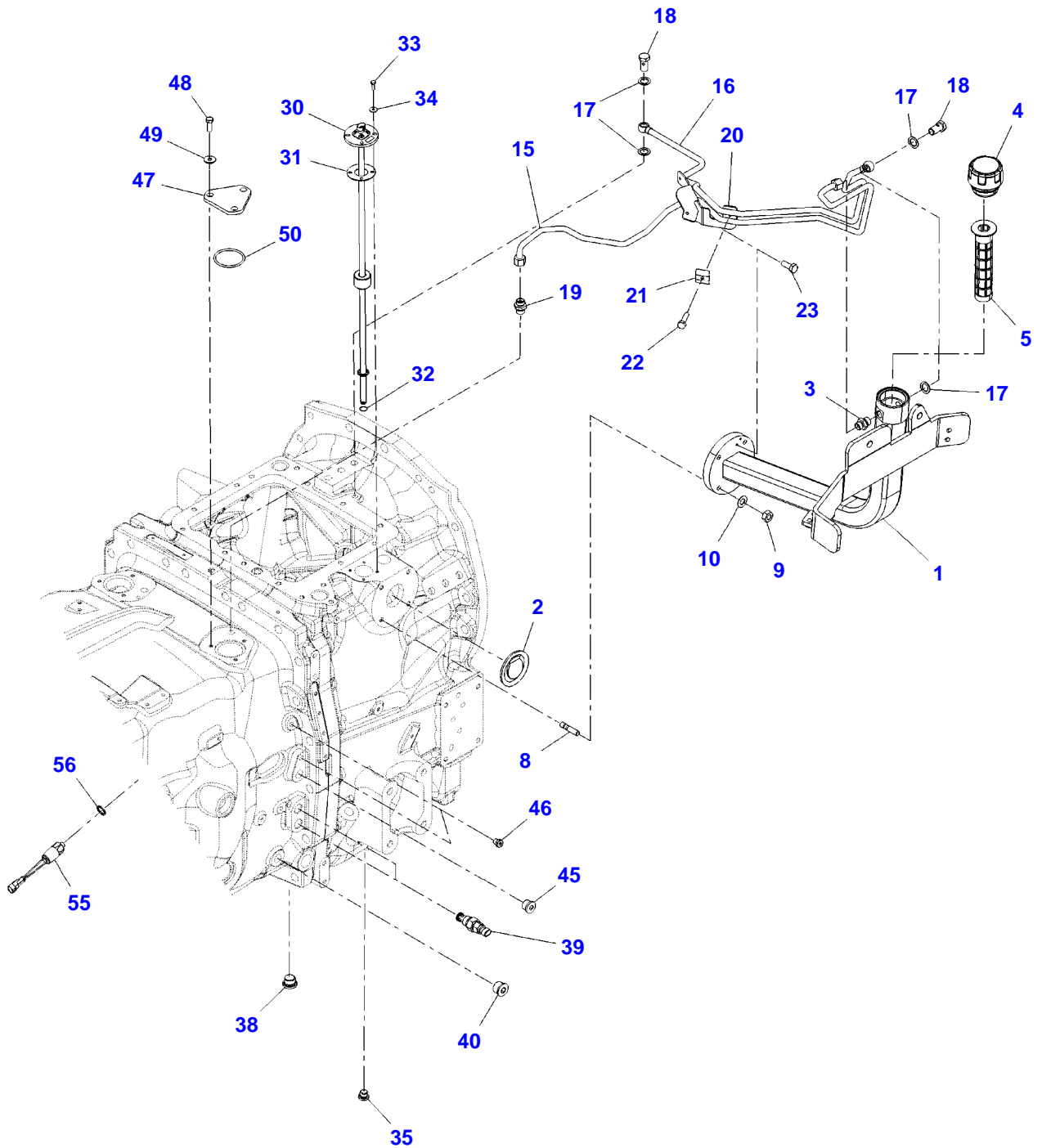



Suggest:

For more complete manuals. Please go to the home page.

<https://www.ebooklibonline.com>

If the above button click is invalid. Please download this document first, and then click the above link to download the complete manual.

Thank you so much for reading

Item	Part Number	Qty	Description Comments	Technical Specification
			FROM MACHINE S/N 530/1285	
1	72629563	1	FILLER	
2	72623729	1	SEALING RUBBER	
3	72438330	1	SCREW NECK	FWN65925-L12-M18X1,5OMD-A3L 1
4	72629564	1	VENTILATION FILTER	HYDRAULIK
	72657543	1	O-RING	Ø 58,74X3,53
5	72629565	1	SIEVE	
8	72313777	4	STUD BOLT	DIN 939 M10X35-8.8
9	72313272	4	NUT	DIN 934 M10-8A3L
10	72317122	4	SPRING WASHER	DIN 137 B10-MECH.VZK
15	72624024	1	VENT TUBE	
16	72623688	1	VENT TUBE	
17	72608905	4	GASKETS	14X22X1,5
18	72315808	2	BANJO BOLT	DIN 7643-10-3-A3L
19	72438330	1	SCREW NECK	FWN65925-L12-M18X1,5OMD-A3L 1
20	72623638	1	HOLDER	
21	72311266	1	CLIP	
22	72315633	1	HEXAGONAL HEAD BOLT	DIN 933 M6X25-8.8A3L
23	72315626	2	HEXAGONAL HEAD BOLT	DIN 933-M6 X 16-8.8-A3L
30	72623127	1	FUEL TRANSMITTER INCLUDES ITEMS 31,32	
31	72476833	1	FLANGE WASHER	
32	72451977	1	O-RING	D9X2,5
33	72315619	4	HEXAGONAL HEAD BOLT	DIN 933 M5X16-8.8A3L
34	72311819	4	DISC	DIN9021-5,3-140HV-A3R
35	72478716	1	PLUG SCREW	DIN 908 M16X1,5-ED-A3L
38	72438052	1	PLUG SCREW	
39	72618272	2	FLOWMETER	
40	72317613	1	PLUG SCREW NOT USED AT REAR POWER LIFT	VSTIM22X1,5EDFPMA3C
45	72317613	1	PLUG SCREW	VSTIM22X1,5EDFPMA3C
46	72315449	2	PLUG SCREW NOT USED AT 2ND CIRCUIT HYDR. 1 X	FWN64838-M12X1,5-ED-FPM
47	72629560	1	PLATE NOT USED AT 2ND CIRCUIT HYDR.	
48	72315653	3	HEXAGONAL HEAD BOLT NOT USED AT 2ND CIRCUIT HYDR.	DIN 933 M8 X 25-8.8A3L
49	72311824	3	DISC NOT USED AT 2ND CIRCUIT HYDR.	DIN9021-8,4-140HV-A3L
50	72437222	1	O-RING NOT USED AT 2ND CIRCUIT HYDR.	60X4-NBR 70 FWN56402
55	72453413	1	PRESSURE SWITCH	
56	72315090	1	SEALING WASHER	DIN 7603 A12X15,5-CU

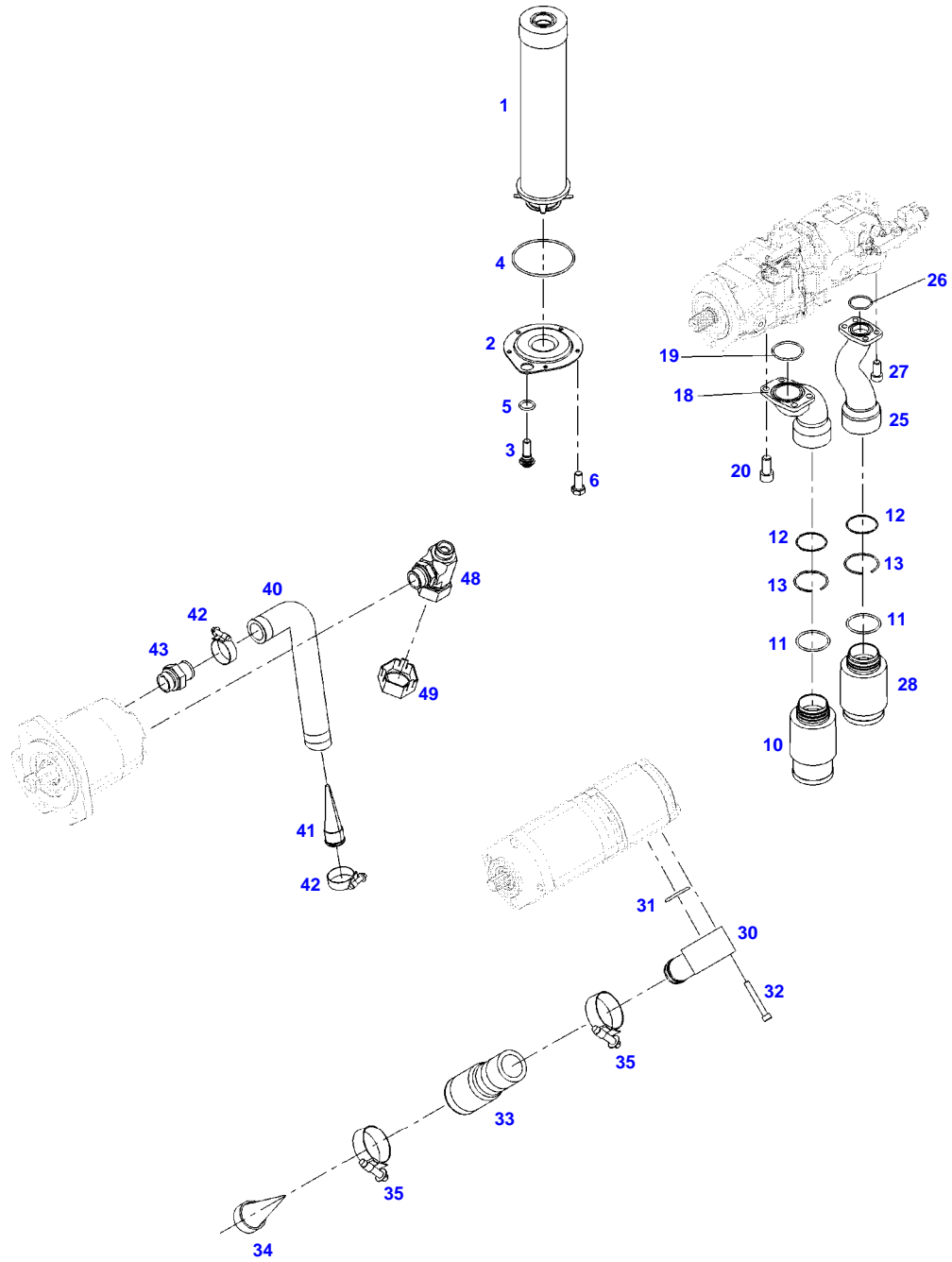

F061011



Item	Part Number	Qty	Description Comments	Technical Specification
FILTER				
1	72620607	1	RETURN FILTER INCLUDES ITEMS 4	
2	72475637	1	COVER INCLUDES ITEMS 4	
3	72436853	1	SCREW INCLUDES ITEMS 5	
4	72474606	1	O-RING 117X4MM	Ø 117X4 MM
5	72493820	1	O-RING	
6	72315650	5	HEXAGONAL HEAD BOLT	DIN 933 M8 X 20-8.8A3L
10	72451933	1	SUCTION FILTER	
11	72437222	2	O-RING	60X4-NBR 70 FWN56402
12	72313484	2	O-RING	57X2,5-NBR 70 FWN56402
13	72375821	2	LOCKWASHER	DIN 7993-B65
18	72623727	1	SUCTION FLANGE	
19	72453085	1	O-RING	56,74X3,53-NBR 90 FWN56402
20	72374067	4	SOCKET HEAD BOLT	DIN 912-M12X25-8.8
25	72623728	1	SUCTION FLANGE	
26	72313473	1	O-RING	40,2X3-NBR 70 FWN56402
27	72315492	4	SOCKET HEAD BOLT	DIN 912 M10X25-8.8
28	72438395	1	SUCTION FILTER	
30	72491052	1	SUCTION FLANGE	
31	72313451	1	O-RING	24X2,5-NBR 70 FWN56402
32	72374011	3	SOCKET HEAD BOLT	DIN 912 M6X45-8.8
33	72623178	1	SUCTION HOSE	
34	72441403	1	PREFILTER	
35	72311162	2	HOSE CLIP	
40	72619874	1	SUCTION HOSE	
41	72356070	1	PREFILTER	
42	72311168	2	HOSE CLIP	
43	72437834	1	SUCTION NOZZLE	
48	72652995	1	T-FITTING	
49	72451824	1	SUCTION FILTER	

<https://www.ebooklibonline.com>

Hello dear friend!

Thank you very much for reading.

Enter the link into your browser.

The full manual is available for immediate download.

<https://www.ebooklibonline.com>