

**TABLE OF CONTENT**

<b>Page Number</b>	<b>Page Title</b>	<b>Page Reference</b>
01-000-TOC	ENGINE, FUEL AND EXHAUST SYSTEM	01-000-TOC
02-000-TOC	AXLES	02-000-TOC
03-000-TOC	STEERING SYSTEM	03-000-TOC
04-000-TOC	DRIVE TRAIN SYSTEM	04-000-TOC
05-000-TOC	COMPRESSED AIR SYSTEM	05-000-TOC
06-000-TOC	HYDRAULIC SYSTEM	06-000-TOC
07-000-TOC	ELECTRICAL SYSTEM	07-000-TOC
08-000-TOC	CAB	08-000-TOC
09-000-TOC	AIR CONDITIONING AND HEATING SYSTEM	09-000-TOC
10-000-TOC	CHASSIS	10-000-TOC
11-000-TOC	DECALS	11-000-TOC
12-000-TOC	WHEELS	12-000-TOC
13-000-TOC	IMPLEMENT LIFT SYSTEM FRONT	13-000-TOC
14-000-TOC	IMPLEMENT LIFT SYSTEM REAR	14-000-TOC
15-000-TOC	LINKAGE	15-000-TOC
16-000-TOC	PRECISION FARMING SYSTEMS	16-000-TOC
17-000-TOC	ACCESSORIES	17-000-TOC

Page Number	Page Title	Page Reference
01-0001	OVERVIEW - FILTER	2015025
01-0002	ENGINE AND MOUNTING	1959418
01-0003	CRANKCASE	1958234
01-0004	TIMING GEARS AND HOUSING	1958235
01-0005	FLYWHEEL AND HOUSING	1958236
01-0006	CRANKSHAFT AND PISTONS	1958237
01-0007	CAMSHAFT AND VALVE	1958277
01-0008	CYLINDER HEAD AND VALVES	1958304
01-0009	VALVE COVER	1958321
01-0010	AIR INTAKE	1958322
01-0011	EXHAUST MANIFOLD	1958332
01-0012	TURBOCHARGER	1958335
01-0013	EXHAUST GAS RECIRCULATION (EGR) UP TO ENGINE S/N 52245781864573	1958341
01-0014	EXHAUST GAS RECIRCULATION (EGR) FROM ENGINE S/N 52245782604573	2225125
01-0015	OIL PUMP AND SUMP	1958405
01-0016	OIL COOLER AND FILTER	1958408
01-0017	COOLANT PIPING	1958411
01-0018	COOLANT PUMP AND THERMOSTAT	1958419
01-0019	FUEL INJECTION SYSTEM	1958434
01-0020	FUEL FILTERS	1958439
01-0021	FUEL PRE-FILTER	1962460
01-0022	FUEL TANK - LEFT HAND	1962450
01-0023	FUEL TANK - RIGHT HAND UP TO MACHINE S/N 530/1258	1962451
01-0024	FUEL TANK - RIGHT HAND FROM MACHINE S/N 530/1259	2216652
01-0025	FUEL LINES	1962468
01-0026	ELECTRONIC ENGINE MANAGEMENT - SENSOR	1959047
01-0027	ELECTRONIC ENGINE MANAGEMENT - WIRING HARNESS	1961332
01-0028	ELECTRONIC ENGINE MANAGEMENT - SUPPORT BRACKET	1961372
01-0029	WIRING HARNESS - INJECTOR	1961376
01-0030	WIRING HARNESS - STARTER MOTOR	1961374
01-0031	STARTER MOTOR AND FENDER	1961375
01-0032	ALTERNATOR	1961377
01-0033	BELT - BELT TENSIONER	1958448
01-0034	ENGINE GASKETS SETS	1958495
01-0035	SPECIAL OVERHAUL PARTS	1958253
01-0036	FAN	1960747
01-0037	COOLER - COVER ASSEMBLY	1960766
01-0038	WATER COOLED RADIATOR	1960758
01-0039	CHARGE AIR COOLER - OIL COOLER	1960815
01-0040	COOLANT PIPING - EXPANSION TANK	1960826
01-0041	COOLANT PIPING - TANK ADBLUE	1960839
01-0042	AIR FILTER	1960848
01-0043	AIR FILTER - RETAINER	1960849
01-0044	SILENCER	1962448
01-0045	SILENCER - CONSOLE UP TO MACHINE S/N WAM530XXX00F05010	1962357
01-0046	SILENCER - CONSOLE FROM - UP TO MACHINE S/N WAM530XXX00F05011 - WAM530XXX00F05565	2216716
01-0047	SILENCER - CONSOLE FROM MACHINE S/N WAM530XXX00F05566	2590979
01-0048	EXHAUST AFTER-TREATMENT UP TO MACHINE S/N WAM530XXX00F05565	1962151
01-0049	EXHAUST AFTER-TREATMENT FROM MACHINE S/N WAM530XXX00F05566	2588786

<b>Page Number</b>	<b>Page Title</b>	<b>Page Reference</b>
01-0050	EXHAUST AFTER-TREATMENT - TANK ADBLUE PIPING UP TO MACHINE S/N WAM530XXX00F05545	1962152
01-0051	EXHAUST AFTER-TREATMENT - TANK ADBLUE PIPING FROM MACHINE S/N WAM530XXX00F05546	2574548
01-0052	EXHAUST BRAKE	1962505
01-0053	SPEED CONTROL	1962521
01-0054	ENGINE PRE-HEATER	1962513

**<https://www.ebooklibonline.com>**

Hello dear friend!

Thank you very much for reading.

Enter the link into your browser.

The full manual is available for immediate download.

**<https://www.ebooklibonline.com>**

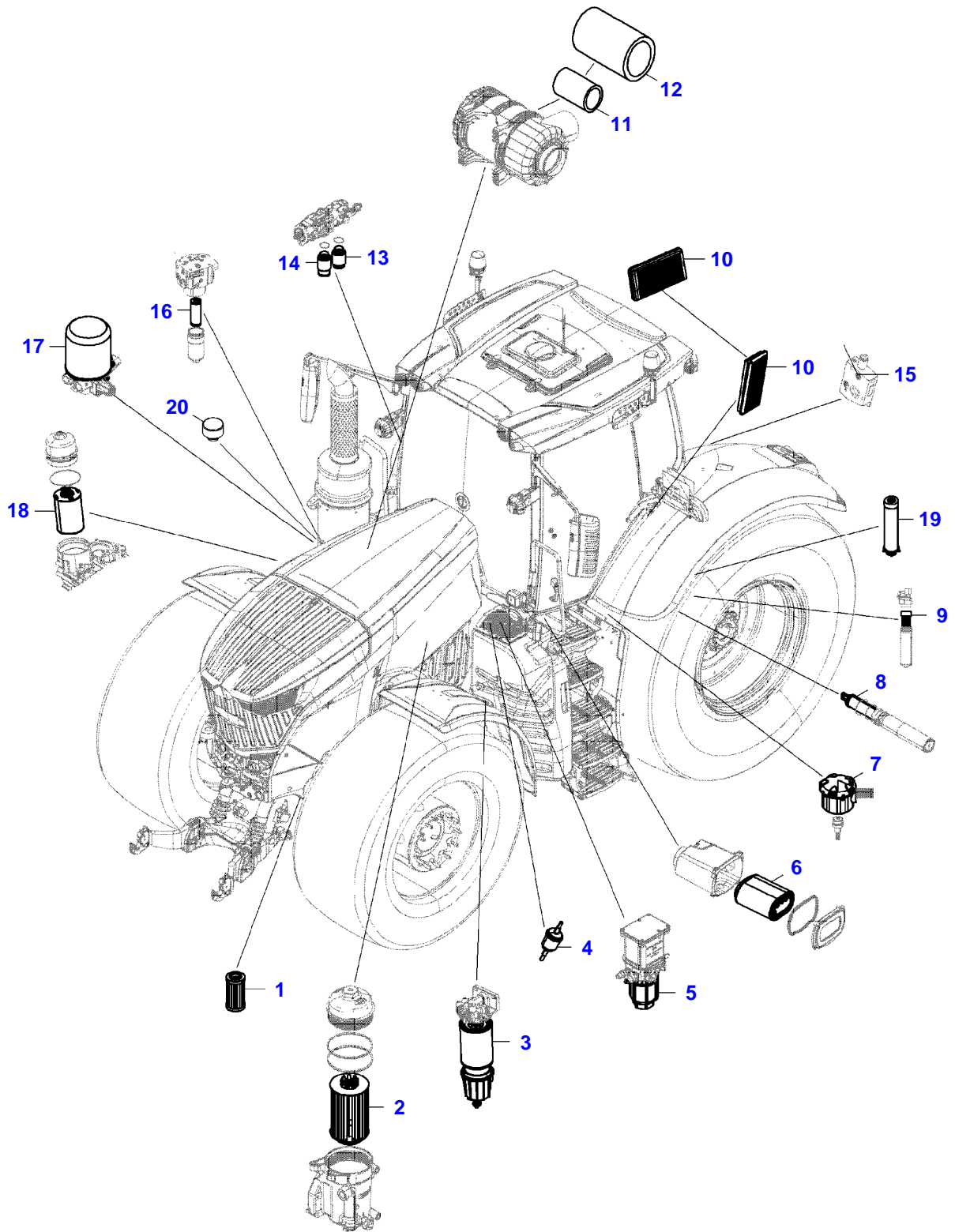

14430928-M-1

Item	Part Number	Qty	Description Comments	Technical Specification
1	72623924	1	FILTER AXLE HOUSING SEE PAGE 02-0002	FILTEREINSATZ-VORDERACHSE
2	ACP0153530	1	FILTER ELEMENT FUEL FILTER SEE PAGE 01-0020	
3	72614253	1	FILTER ELEMENT PRE FUEL FILTER SEE PAGE 01-0021	
4	72484191	1	FILTER PREFILTER ADBLUE SEE PAGE 01-0050	
5	ACP0153520	1	DEF FILTER ADBLUE SEE PAGE 01-0050	
6	72620540	1	FILTER CARTRIDGE FRESH AIR SEE PAGE 08-0043	
7	ACP0225000	1	FILTER ELEMENT FUEL AIR CLEANER SEE PAGE 01-0022	
8	72621035	1	FILTER ELEMENT PUMP DRIVE SEE PAGE 04-0052	GETRIEBEOEL
9	72488569	1	FILTER ELEMENT VALVES COMFORT SYSTEM SEE PAGE 04-0056	
10	72620539	2	FILTER CAB AIR RECIRCULATION SEE PAGE 08-0042	
11	72622475	1	SECONDARY AIR FILTER ELEMENT SEE PAGE 01-0042	
12	72622474	1	PRIMARY AIR FILTER ELEMENT SEE PAGE 01-0042	
13	72438395	1	SUCTION FILTER OIL TANK SEE PAGE 14-0016	
14	72451933	1	SUCTION FILTER OIL TANK SEE PAGE 14-0016	
15	72470364	1	FILTER END PLATE SEE PAGE 06-0045	
16	72493246	1	HYDRAULIC FILTER CENTRAL CONTROL BLOCK SEE PAGE 06-0077	STEUERDRUCK
17	72437515	1	CARTRIDGE JET AIR DRIER SEE PAGE 05-0005	LUFTTROCKNER
18	ACP0154860	1	FILTER CARTRIDGE OIL FILTER SEE PAGE 01-0016	
19	72620607	1	RETURN FILTER OIL TANK SEE PAGE 14-0016	
20	72364577	1	VENTILATION FILTER OIL FILLING SOCKET SEE PAGE 14-0013 FROM - UP TO MACHINE S/N 530/1001 - 530/1284	

Fendt

FENDT 1050NA S4 (530/00101-05000) (WAM530XXX00F05001-99999)

F530105

OVERVIEW - FILTER

Page01-0001

Item	Part Number	Qty	Description Comments	Technical Specification
	72629564	1	VENTILATION FILTER OIL FILLING SOCKET SEE PAGE 14-0014 FROM MACHINE S/N 530/1285	HYDRAULIK

FENDT 1050NA S4 (530/00101-05000) (WAM530XXX00F05001-99999)  
12937280-M-1

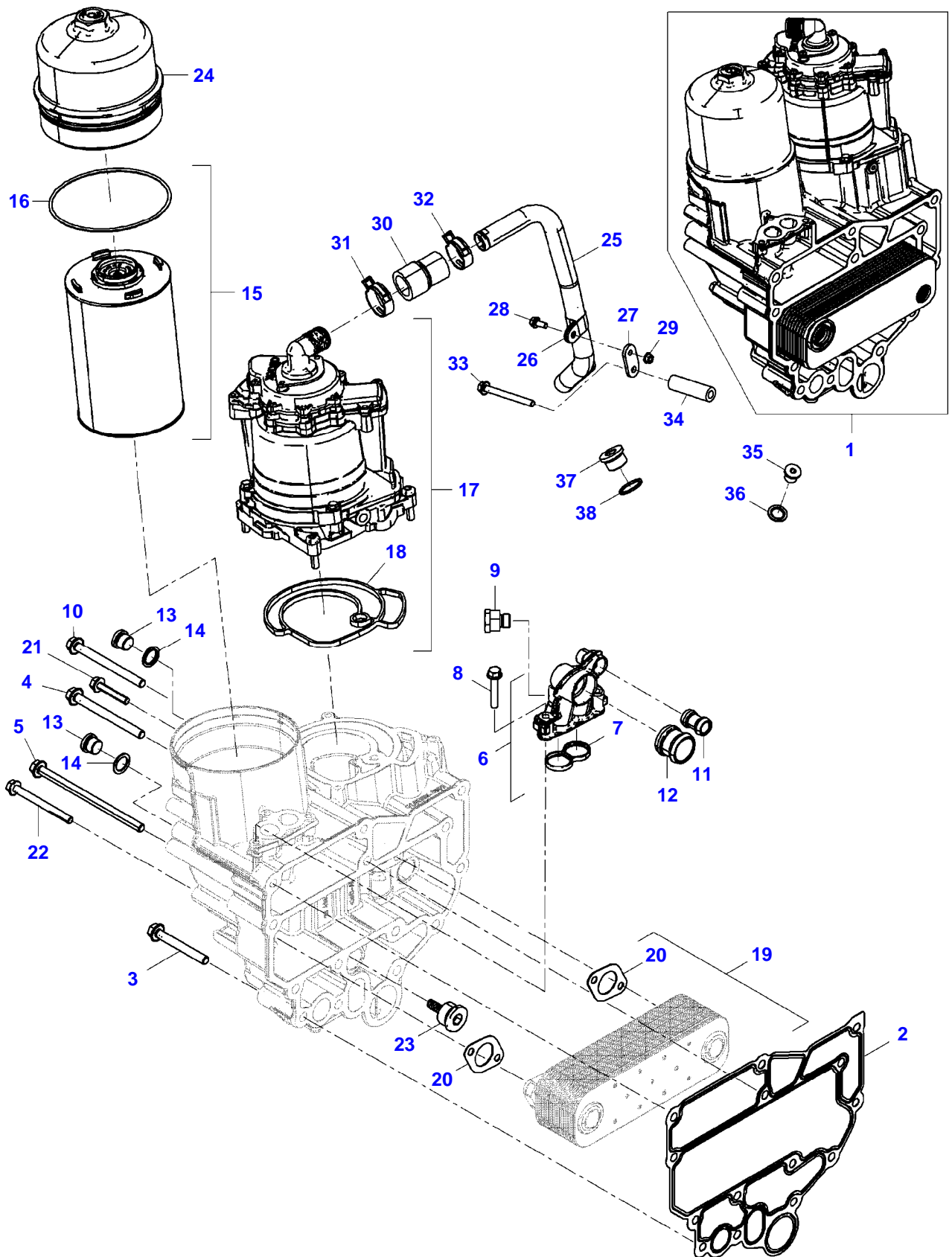

23235644-M-1

Item	Part Number	Qty	Description Comments	Technical Specification
1	ACP0300530	1	OIL MODULE ASSEMBLY INCLUDES ITEMS 15-24	
2	ACP0411280	1	GASKET	
3	72624244	8	HEX FLANGE CAPSCREW	M10X80-10.9
4	72627945	4	HEX FLANGE CAPSCREW	M10X160
5	72627915	2	HEX FLANGE CAPSCREW	
6	ACP0353570	1	FLANGE INCLUDES ITEMS 7	
7			NOT AVAILABLE IN SINGLE PARTS	
8	72624663	3	HEX FLANGE CAPSCREW	M8X45-10.9
9	72657407	1	SCREW NECK	M16X1,5/M18X1,5
10	72627945	1	HEX FLANGE CAPSCREW	M10X160
11	72624609	1	EXTENSION TUBE	
12	72624610	1	EXTENSION TUBE	
13	72629226	2	PLUG SCREW	
14	72623466	2	SEALING WASHER	PCS-18,3X26-ST/FKM1-80
15	ACP0154860	1	FILTER CARTRIDGE INCLUDES ITEMS 16	
16	72624577	1	O-RING SEAL	126X4
17	ACP0300540	1	OIL SEPARATOR INCLUDES ITEMS 18	
18	72627918	1	GASKET	
19	72627919	1	OIL COOLER INCLUDES ITEMS 20	
20	72627920	2	OIL COOLER SEAL	
21	72624219	2	HEX FLANGE CAPSCREW	M8X45-8.8
22	72624220	2	HEX FLANGE CAPSCREW	M8X90-8.8
23	72624396	1	PRESSURE-RELIEF VALVE	
24	72624398	1	LID	
25	72624343	1	BREATHER LINE INCLUDES ITEMS 26-29	
26	72624317	1	BRACKET CLAMP	A1-22X20-W4
27	72624492	1	HOLDER	
28	72624207	1	HEXAGONAL HEAD BOLT	M8X20-10.9
29	72624274	1	HEX NUT	M8-8
30	72624572	1	HOSE	
31	72605607	1	CLIP	
32	72608303	1	CLIP	
33	72624245	1	HEX FLANGE CAPSCREW	M10X100-10.9
34	72649480	1	BUSHING	12,5X24X80
35	72629224	1	PLUG SCREW	
36	72624303	1	SEALING WASHER	14,3X22X1,5-ST/FKM1-80
37	72624273	1	PLUG SCREW	M24X1,5-ST-M3360-RK12-K
38	72624296	1	SEALING WASHER	A24X29-CU

FENDT 1050NA S4 (530/00101-05000) (WAM530XXX00F05001-99999)  
 12940285-M-1

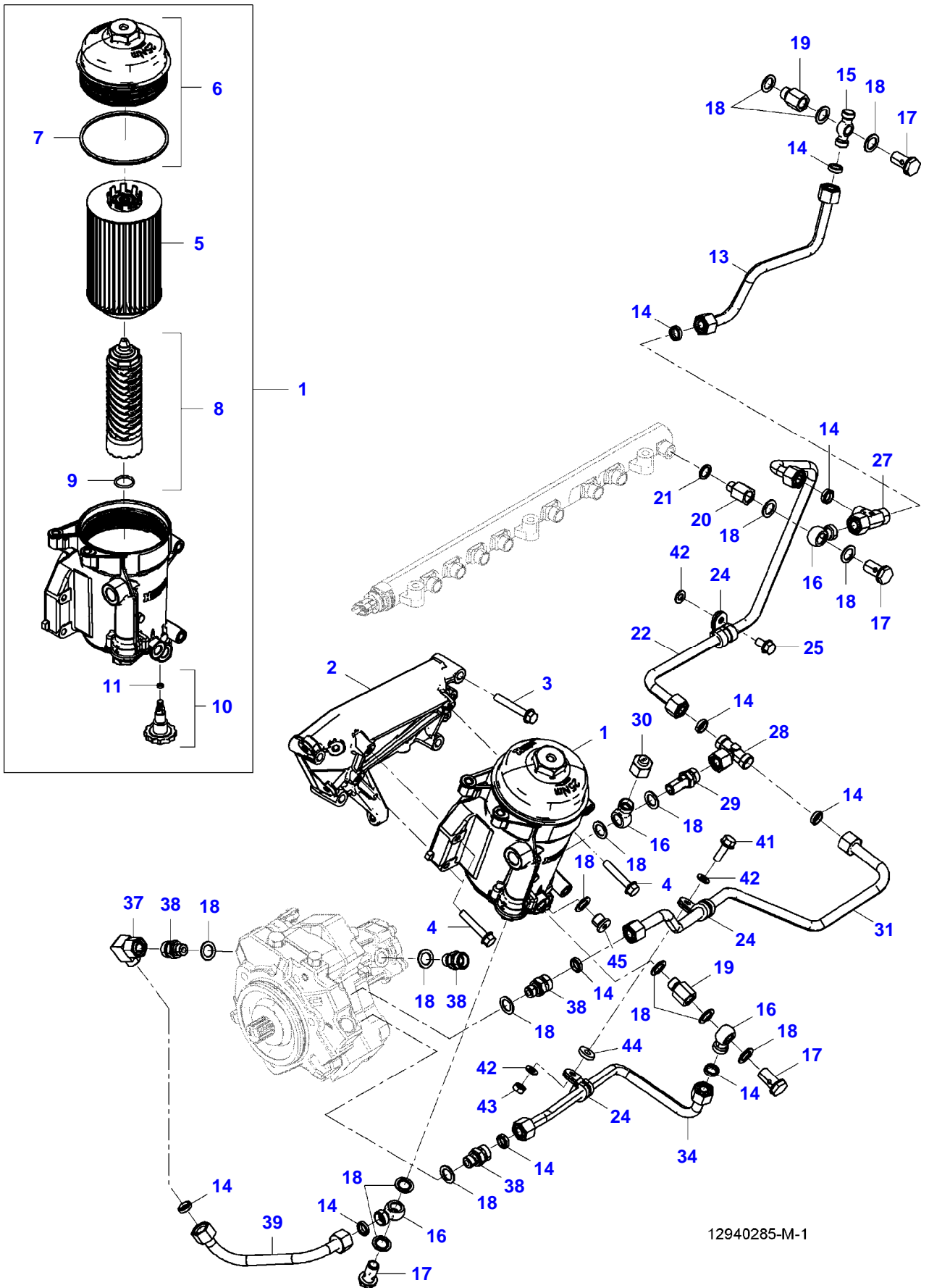

12940285-M-1

## FUEL FILTERS

Item	Part Number	Qty	Description Comments	Technical Specification
1	72624483	1	FUEL FILTER INCLUDES ITEMS 5-11	
2	72624488	1	HOLDER	
3	72624235	4	HEX FLANGE CAPSCREW	M8X55-10.9
4	72624663	3	HEX FLANGE CAPSCREW	M8X45-10.9
5	ACP0410280	1	FILTER ELEMENT	
6	72624485	1	LID INCLUDES ITEMS 7	
7	72624574	1	O-RING SEAL	100X4-HNBR-60
8	72624484	1	SUPPORT PIPE INCLUDES ITEMS 9	
9	72624298	1	O-RING SEAL	18X2,5B-FKM1-70-GN
10	72624542	1	DRAIN PLUG INCLUDES ITEMS 11	
11	72624575	1	O-RING SEAL	4,5X2-FPM
13	72624482	1	FUEL LINE INCLUDES ITEMS 14	12X1,5
14	72624576	10	SEALING WASHER	E02-12L-ST-VITON
15	72624593	1	BANJO UNION	
16	72346246	4	RING FITTING	
17	72417155	4	BANJO BOLT	
18	72624303	17	SEALING WASHER	14,3X22X1,5-ST/FKM1-80
19	72316290	2	NOZZLE	
20	72624600	1	REDUCING STUD	M12X1,5/M14X1,5
21	72624302	1	SEALING WASHER	12,3X18X1,5-ST/FKM1-80
22	72624481	1	FUEL LINE INCLUDES ITEMS 23,24	12X1,5
24	72608293	3	CLIP	
25	72624230	1	HEX FLANGE CAPSCREW	M8X20-10.9
27	72624324	1	DIVIDER UNION	L12-NBR
28	72624596	1	T-FITTING	L12
29	72624604	1	BANJO BOLT	
30	72624543	1	LOCKING PLUG	M18X1,5
31	72624480	1	FUEL LINE INCLUDES ITEMS 32,33	12X1,5
34	72624479	1	FUEL LINE INCLUDES ITEMS 35,36	12X1,5
37	72624597	1	SOCKET	L12-ST
38	72624598	4	SOCKET	L12M14X1,5-ST
39	72624478	1	FUEL LINE INCLUDES ITEMS 40	
41	72624231	1	HEX FLANGE CAPSCREW	M8X25-10.9
42	72649375	3	WASHER	8X16X1,6-200HV
43	72624274	1	HEX NUT	M8-8
44	72624549	1	WASHER	8,4X20X4-9SMNPB28K
45	72624271	1	PLUG SCREW	M14X1,5-ST-M3360-RK10-K

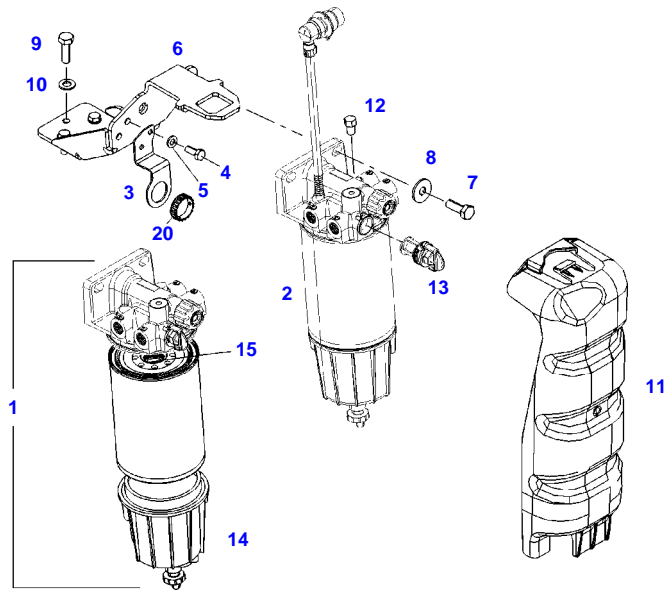

F061570



Item	Part Number	Qty	Description Comments	Technical Specification
1	72623758	1	FUEL PREFILTER INCLUDES ITEMS 12-15	
2	72623759	1	FUEL PREFILTER HEATED INCLUDES ITEMS 12-15	
3	72619544	1	ANGLE	
4	72315626	2	HEXAGONAL HEAD BOLT	DIN 933-M6 X 16-8.8-A3L
5	72311787	2	DISC	DIN 125-6,4-ST.A3L
6	72623755	1	HOLDER UP TO MACHINE S/N WAM530XXX00F05549	
	72655509	1	HOLDER FROM MACHINE S/N WAM530XXX00F05550	
7	72315685	2	HEXAGONAL HEAD BOLT	DIN 933 M10X30-8.8A3L
8	72311827	2	DISC	DIN9021-10,5-140HV-A3L
9	72315653	3	HEXAGONAL HEAD BOLT	DIN 933 M8 X 25-8.8A3L
10	72311788	3	DISC	DIN 125-8,4-ST.A3L
11	72600654	1	COVERING	
12	72470047	1	BLEED SCREW	
13	72610620	1	THERMOSTATIC VALVE	
14	72440017	1	CONTAINER B091	
15	72614253	1	FILTER ELEMENT	
20	72485325	1	MOUNTING RING	

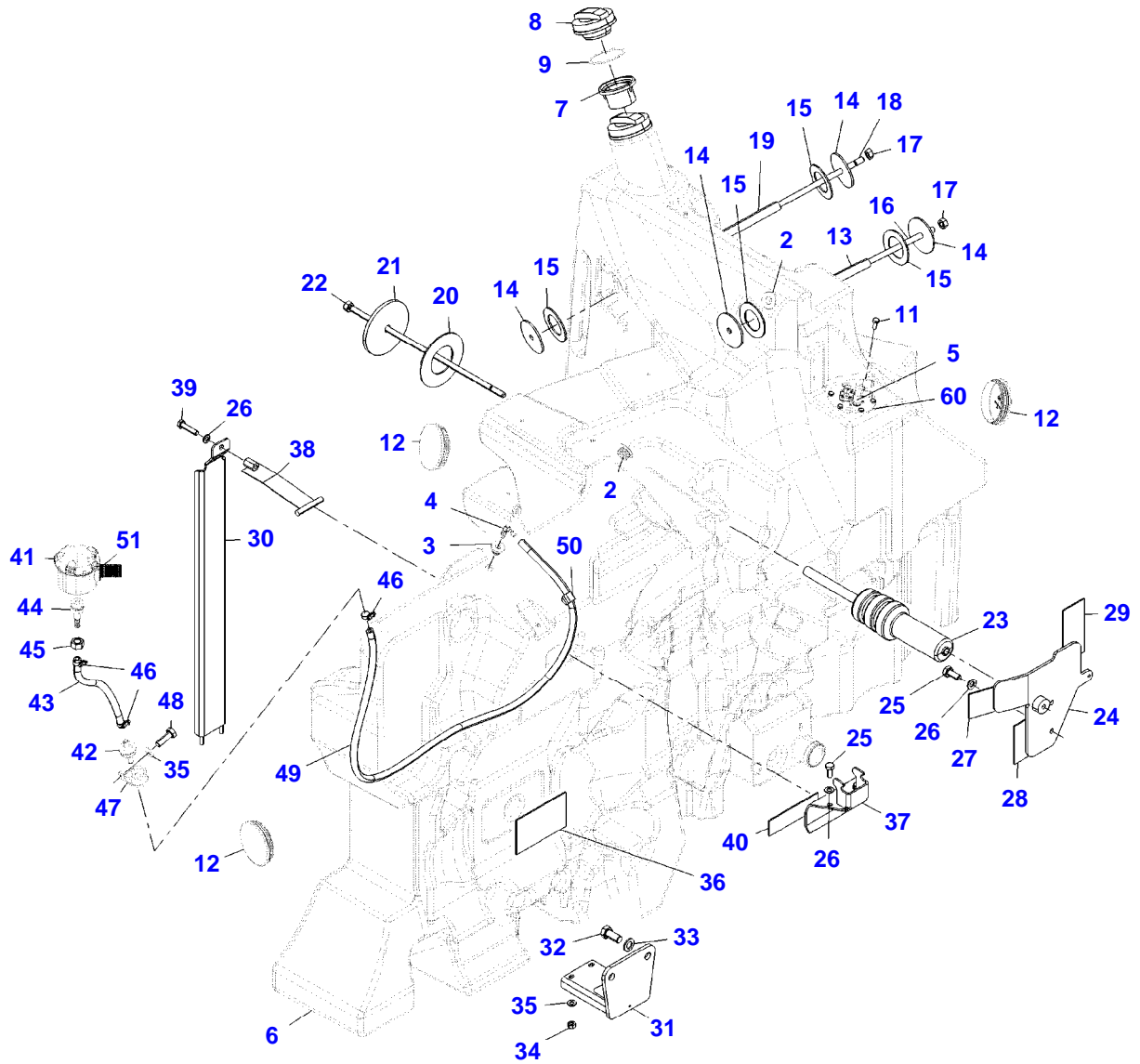

13071451-M-1

Item	Part Number	Qty	Description Comments	Technical Specification
2	72619547	2	GROMMET	
3	72441345	1	SPOUT	
4	72478216	1	REDUCING ELBOW HOSE CONNECTION	
5	72623754	1	FUEL TRANSMITTER	
6	72649570	1	FUEL TANK INCLUDES ITEMS 7-10	LI
7	72419182	1	THREADED INSERT	
8	72417260	1	FUEL CAP	
	72423400	1	FUEL CAP LOCKABLE	
9	72452730	1	O-RING	75X4-70 FPM 173104 FWN56402
11	ACW0775760	6	HEXAGON FLANGE BOLT	EN1665 M6X1X16-8 VDA30
12	72441667	3	LOCKING PLUG	GL102
13	72619549	1	SPACER TUBE	
14	72619542	4	DISC	
15	72619543	4	FELT DISC	
16	72624173	1	THREAD BOLT	
17	72313276	2	NUT	DIN 934 M12-8A3L
18	72624172	1	THREAD BOLT	
19	72619551	1	SPACER TUBE	
20	72437083	1	FELT WASHER	
21	72437598	1	DISC	
22	72624171	1	THREAD BOLT	
23	72631198	1	HOLDER	
24	72623756	1	HOLDER	
25	72315681	5	HEXAGONAL HEAD BOLT	DIN 933 M10X25-8.8A3L
26	72311789	6	DISC	DIN 125-10,5-ST.A3L
27	72619019	1	FELT STRIP	3X65X84_FWN63024
28	72619015	1	FELT STRIP	3X55X100_FWN63024
29	72619020	1	FELT STRIP	3X65X140_FWN63024
30	72620338	1	STAY	
31	72620333	1	TANK SUPPORT	
32	72315732	2	HEXAGONAL HEAD BOLT	DIN 933 M16X35-8.8A3L
33	72311793	2	DISC	DIN 125-17-ST.A3L
34	72313268	2	NUT	DIN 934 M8-8A3L
35	72311788	3	DISC	DIN 125-8,4-ST.A3L
36	72619026	1	FELT STRIP	3X90X150_FWN63024
37	72619548	1	SHEET METAL	
38	72620337	1	BAND CLAMP	
39	72315693	1	HEXAGONAL HEAD BOLT	DIN 933 M10X45-8.8A3L
40	72619013	1	FELT STRIP	3X40X150_FWN63024
41	72623748	1	AIR FILTER INCLUDES ITEMS 51	
42	4351598M1	1	NON RETURN VALVE	
43	72486217	1	PRESSURE HOSE CUT TO LENGTH L=250MM	L=0,280
44	72623753	1	UNION	
45	72313286	1	NUT	DIN 934 M16X1,5-8A3L
46	72438345	3	HOSE CLIP	
47	72311252	1	PIPE CLAMP	
48	72315653	1	HEXAGONAL HEAD BOLT	DIN 933 M8 X 25-8.8A3L
49	72420605	1	PRESSURE HOSE CUT TO LENGTH L=1650 MM	L=1750 E9X3 FWN 66041
50	72418527	1	CLIP	WELLROHR
51	ACP0225000	1	FILTER ELEMENT	
60	72643192	1	FLANGE WASHER	

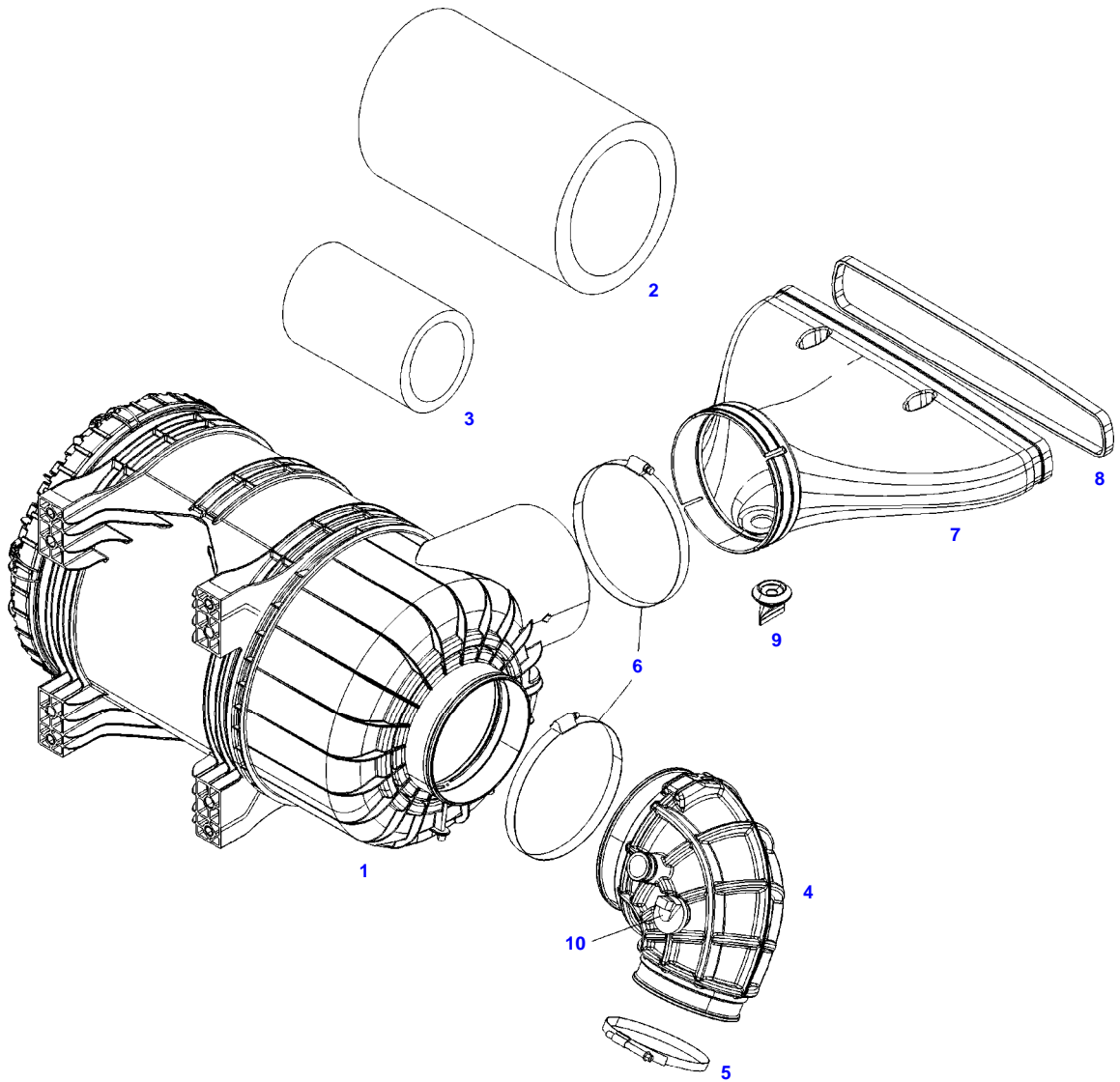

F061214



## AIR FILTER

Item	Part Number	Qty	Description Comments	Technical Specification
1	72620063	1	AIR FILTER INCLUDES ITEMS 2,3	
2	72622474	1	PRIMARY AIR FILTER ELEMENT	
3	72622475	1	SECONDARY AIR FILTER ELEMENT	
4	72620064	1	AIR INTAKE HOSE	
5	72311175	1	HOSE CLIP	
6	72493427	2	HOSE CLIP	180-200
7	72619556	1	UNTREATED AIR CHANNEL	
8	72621056	1	SEALING STRIP	15X10_L=1,080M
9	72619754	1	SPOUT	
10	72626286	1	MAINTENANCE SWITCH B215	

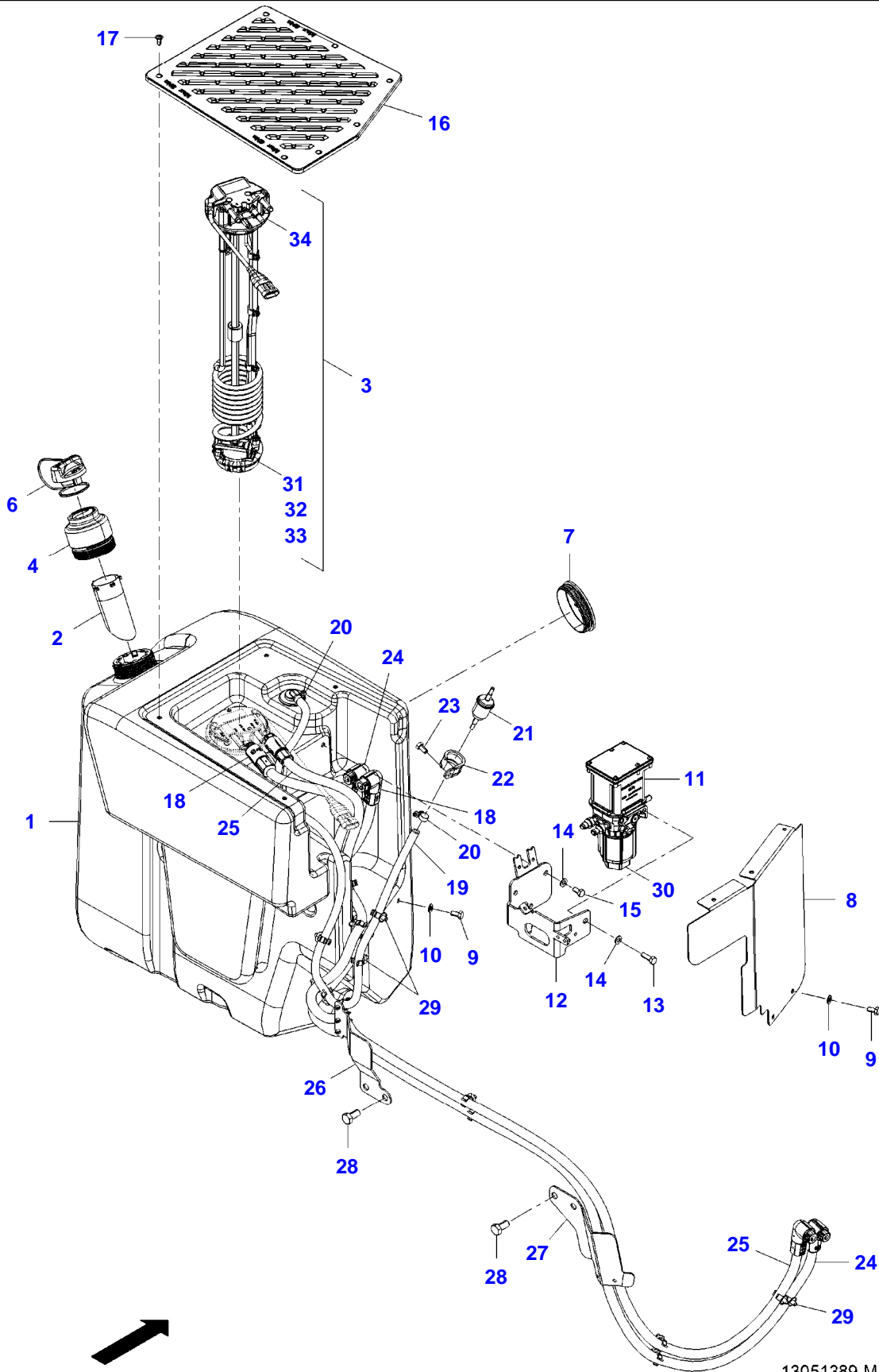

13051389-M-2

Item	Part Number	Qty	Description Comments	Technical Specification
			<b>PIPING UP TO MACHINE S/N WAM530XXX00F05545</b>	
1	72618761	1	DEF TANK	ADBLUE
2	72619577	1	TUBE	
3	72652666	1	DEF SENSOR B195 INCLUDES ITEMS 31-34	
4	72620072	1	FILLER	
6	72489115	1	FUEL CAP LOCKABLE	
	72489117	1	FUEL CAP	
7	72441667	1	LOCKING PLUG	GL102
8	72620362	1	COVER PANEL	
9	72315642	2	HEXAGONAL HEAD BOLT	DIN 933 M8 X 16-8.8A3L
10	72311788	2	DISC	DIN 125-8,4-ST.A3L
11	72620069	1	SUPPLY UNIT A155	DEF
12	72624060	1	HOLDER	
13	72315653	2	HEXAGONAL HEAD BOLT	DIN 933 M8 X 25-8.8A3L
14	72311788	4	DISC	DIN 125-8,4-ST.A3L
15	72315642	2	HEXAGONAL HEAD BOLT	DIN 933 M8 X 16-8.8A3L
16	72620363	1	COVER PANEL WITHOUT FIRE EXTINGUISHER	
17	72441737	7	OVAL HEAD SCREW	WN7381-M6X16-A2 NIRO
18	72620386	1	HOSE LINE	
19	72486267	1	PRESSURE HOSE CUT TO LENGTH L=1,285 MM	L=1,350
20	72438345	2	HOSE CLIP	
21	72484191	1	FILTER	
22	72311252	1	PIPE CLAMP	
23	72315642	1	HEXAGONAL HEAD BOLT	DIN 933 M8 X 16-8.8A3L
24	72624168	1	HOSE LINE	
25	72624169	1	HOSE LINE	
26	72619592	1	HOLDER	
27	72624167	1	HOLDER	
28	72315706	1	HEXAGONAL HEAD BOLT	DIN 933 M12X25-8.8A3L
29	72488959	22	CLIP	SCHLAUCH POM
30	ACP0153520	1	DEF FILTER	
31	ACP0338340	1	DEF FILTER	
32	ACP0338341	1	CLIP	
33	ACP0338342	2	O-RING	
34	ACP0338330	1	O-RING	102.5 X 5.9MM

FENDT 1050NA S4 (530/00101-05000) (WAM530XXX00F05001-99999)  
13541135-M-1

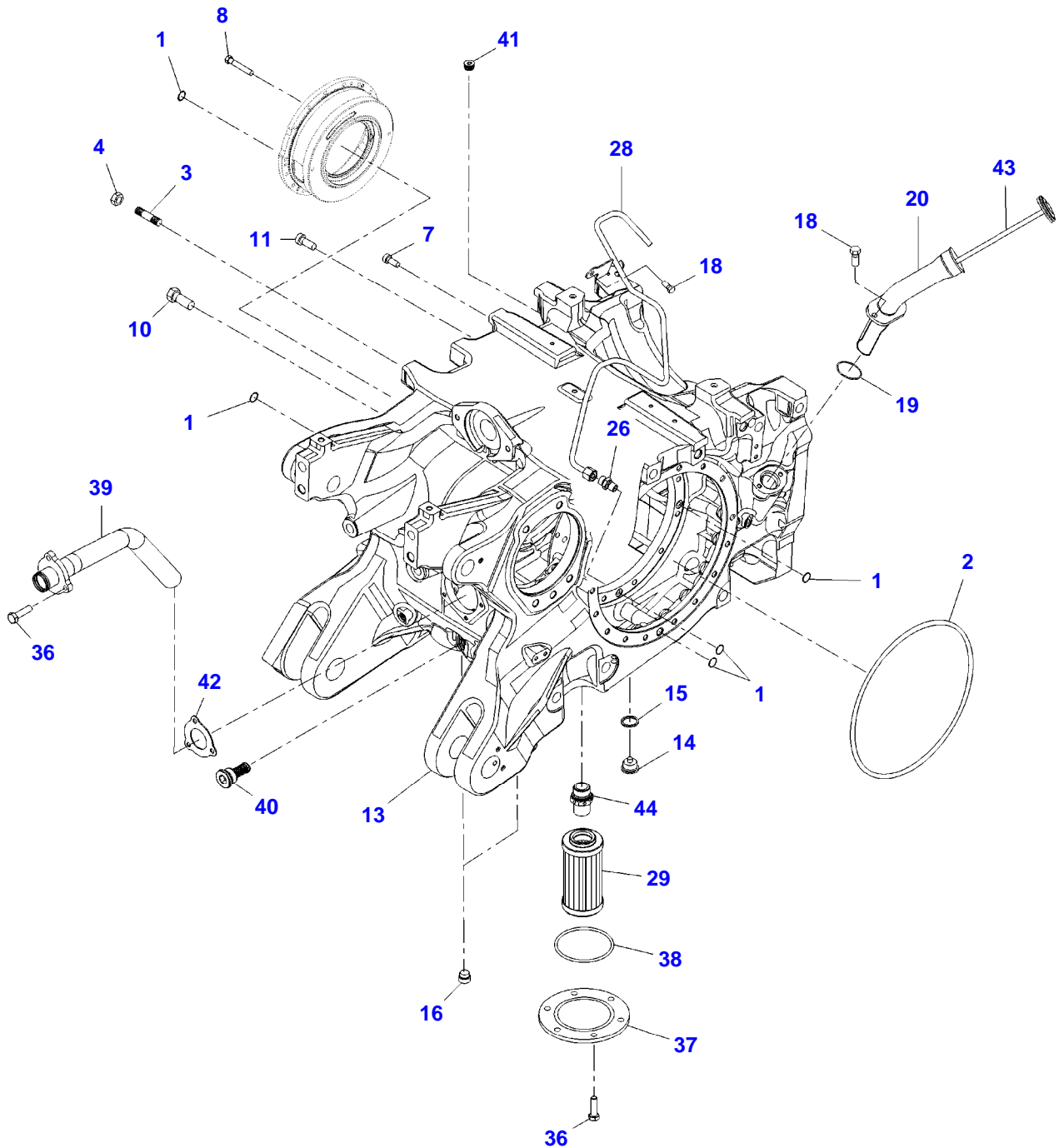

13541135-M-1

Item	Part Number	Qty	Description Comments	Technical Specification
			AXLE NR. 990/050 990/051 990/052 990/053	
1	72620893	5	O-RING	13,1X2,62
2	72620894	2	O-RING	329.79X3.53
3	72620895	2	STUD BOLT	
4	72620896	2	NUT	
7	72620897	3	SOCKET HEAD BOLT	M8X25
8	72617556	16	HEXAGONAL HEAD BOLT	M12X40
10	72620899	14	HEXAGONAL HEAD BOLT	
11	72620900	12	SOCKET HEAD BOLT	
13	72625855	1	HOUSING	
14	72428213	1	SCREW	M30X1,5
15	72376044	1	SEALING WASHER	DIN 7603 A30X38-CU
16	72621023	2	SCREW	M18X1,5
18	72620904	3	SCREW	M8X20
19	72313465	1	O-RING	34X3-FPM 70 FWN56402
20	72625857	1	OIL INFILL	
26	72620907	2	SCREW NECK	D8 M12 M14
28	72625856	1	LUBRICATION LINE	
29	72623924	1	FILTER	FILTEREINSATZ-VORDERACHSE
36	72315655	9	HEXAGONAL HEAD BOLT	DIN 933 M8X30-8.8
37	72625858	1	COVER	
38	72313494	1	O-RING	75,79X3,53-NBR 70-FWN56402
39	72625859	1	INTAKE	
40	72623929	1	CHECK VALVE	
41	72625860	1	SCREW	
42	72625861	1	SEAL	
43	72625880	1	DIPSTICK	
44	72625908	1	VALVE	

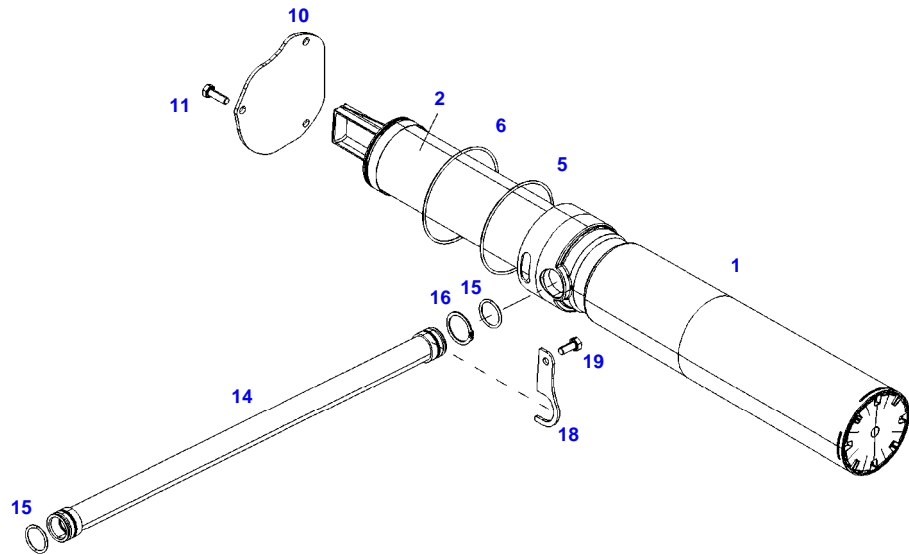

F060817



Item	Part Number	Qty	Description Comments	Technical Specification
1	72620045	1	SUCTION FILTER INCLUDES ITEMS 2	
2	72621035	1	FILTER ELEMENT	GETRIEBEOEL
5	72313503	1	O-RING	105X3-NBR 70 FWN56402
6	72424095	1	O-RING	108X3-NBR 70 FWN56402
10	72619443	1	FILTER LID	
11	72315653	3	HEXAGONAL HEAD BOLT	DIN 933 M8 X 25-8.8A3L
14	72620282	1	SUCTION PIPE	
15	72313458	2	O-RING	27X3-FPM 80 FWN56402
16	72311064	1	LOCK WASHER	DIN 471-32X1,5
18	72619444	1	RETAINING SHEET METAL	
19	72315648	1	HEXAGONAL HEAD BOLT	DIN 933 M8X20-8.8

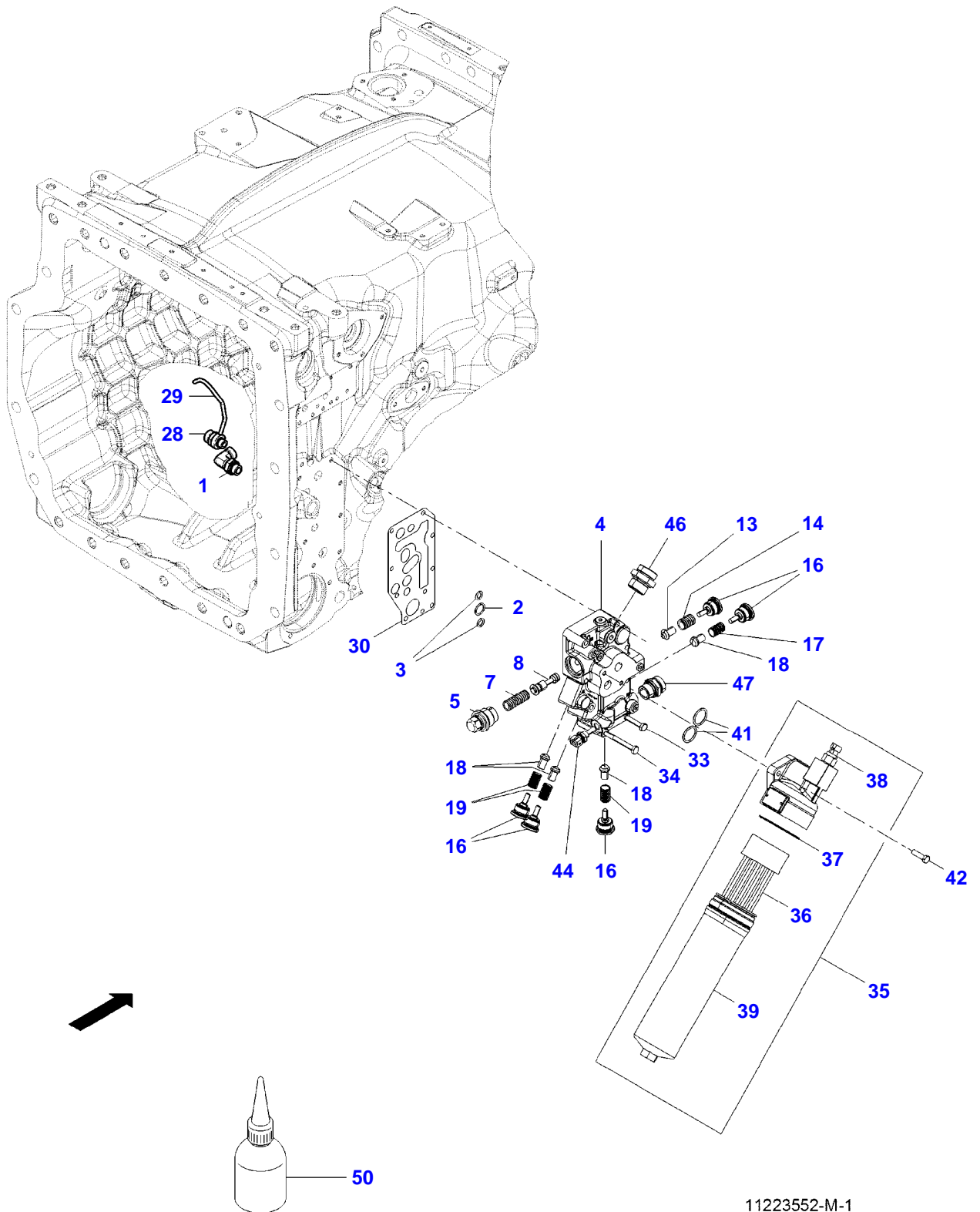

11223552-M-1

Item	Part Number	Qty	Description Comments	Technical Specification
<b>PRESSURE FILTER</b>				
1	72439931	1	ANGULAR THREADED CONNECTION	
2	72313441	1	O-RING	18,72X2,62-NBR 70 FWN56402
3	72313421	2	O-RING	11X3-FPM 80 FWN56402
4	72623535	1	VALVE BLOCK INCLUDES ITEMS 5-19	
	72453370	1	SEAL KIT	
	72312345	1	SEAL	
5	72623536	1	SLEEVE	
7	72316537	1	COMPRESSION SPRING	
8	72441065	1	PISTON	
13	72437531	1	SEALING CONE	
14	72437333	1	COMPRESSION SPRING	
16	72315891	5	SCREW	
17	72316522	1	COMPRESSION SPRING	
18	72311280	4	SEALING CONE	
19	72316539	3	COMPRESSION SPRING	
28	72630140	1	SCREW NECK	
29	72629287	1	LUBRICATING OIL PIPE	
30	72312345	1	SEAL	
33	72315531	7	HEXAGONAL HEAD BOLT	DIN 931 M8 X 60-8.8
34	72315534	1	HEXAGONAL HEAD BOLT	DIN 931 M8 X 70-8.8
35	72617845	1	FILTER INCLUDES ITEMS 36-39	
36	72488569	1	FILTER ELEMENT	
37	72313495	1	O-RING	76X2,5-NBR 70 FWN56402
38			SEE PAGE 07-0011	
39	72485115	1	FILTER HOUSING	
41	72313459	2	O-RING	28X3-NBR 70 FWN56402
42	72315655	2	HEXAGONAL HEAD BOLT	DIN 933 M8X30-8.8
44			SEE ELECTRICAL SYSTEM TRANSMITTER	
46	72316329	1	SCREW NECK	DIN 3901-L28B-M-ST-A3
47	72612237	1	SCREW NECK	DIN3901-L22-M26X1,5-ED
50	72452254	1	THREADLOCKER	LOCTITE 274 10ML

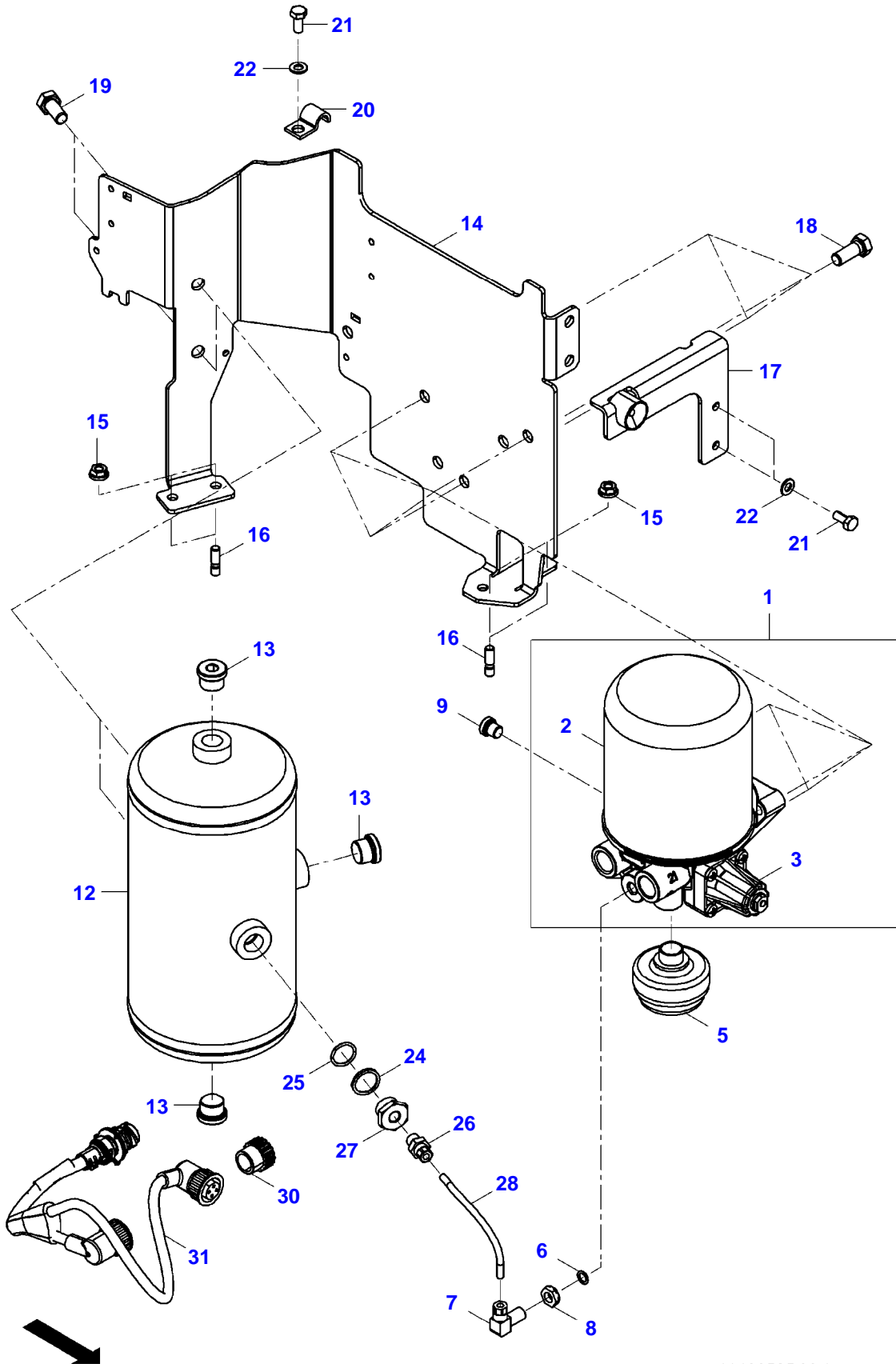

11439535-M-1

Item	Part Number	Qty	Description Comments	Technical Specification
1	72620231	1	AIR DRIER INCLUDES ITEMS 2,3	
2	72437515	1	CARTRIDGE JET	LUFTTROCKNER
3	72455949	1	HEATER	
5	72455889	1	NOISE DAMPER	
6	72313416	1	O-RING	9X2-NBR 70-FWN56402
7	72316989	1	W-E THREADED CONNECTION	STEVBD 6MM
8	72313360	1	SEALING NUT	M12X1,5
9	72315449	1	PLUG SCREW	FWN64838-M12X1,5-ED-FPM
12	72437464	1	AIR TANK	
13	72317613	3	PLUG SCREW	VSTIM22X1,5EDFPA3C
14	72628281	1	HOLDER	
15	72498942	4	HEX NUT	DIN EN1661-M8-8
16	72313770	4	STUD BOLT	FWN64891-M8X20-8.8
17	72625165	1	HOLDER	
18	72476613	3	HEXAGONAL HEAD BOLT	DIN 961 M12X1,5X30-8.8
19	72315706	2	HEXAGONAL HEAD BOLT	DIN 933 M12X25-8.8A3L
20	72387377	1	PIPE CLAMP	
21	72315646	3	HEXAGONAL HEAD BOLT	DIN 933 M8X18-8.8A3L
22	72311788	3	DISC	DIN 125-8,4-ST.A3L
24	72311209	1	THRUST RING	
25	72313445	1	O-RING	20,3X2,4-NBR 70 FWN56402
26	72316988	1	STRAIGHT THREADED CONNECTION	STEVBD
27	72316997	1	REDUCING SCREW CONNECTION	
28	72451279	1	PIPE 1X 150MM CUT TO LENGTH	L=2000MM DIN74324-6X1
30	72482655	1	ELECTRICAL CONNECTOR	
31	72611091	1	KIT, CABLE	

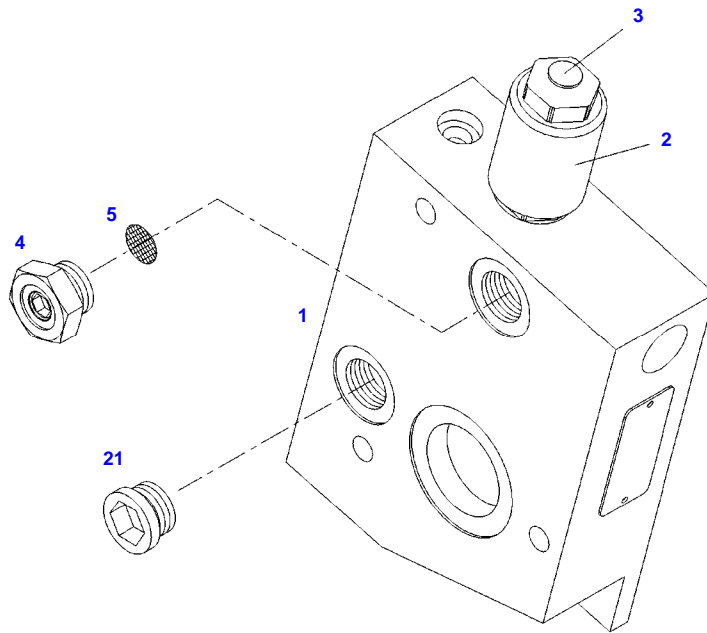

F060965



Item	Part Number	Qty	Description Comments	Technical Specification
			<b>WITH POWER BEYOND CONNECTION</b>	
1	72486753	1	END PLATE INCLUDES ITEMS 2-5	
2	72476782	1	MAGNET COIL	
3	72455766	1	VALVE	
	72489719	1	DUST PLUG SERVICE REPAIR SOLUTION	
4			NOT AVAILABLE IN SINGLE PARTS	
5	72470364	1	FILTER	
21	72315440	1	PLUG SCREW NOT USED AT POWER LIFT SINGLE ACTING	DIN 908 M18 X 1,5-ST

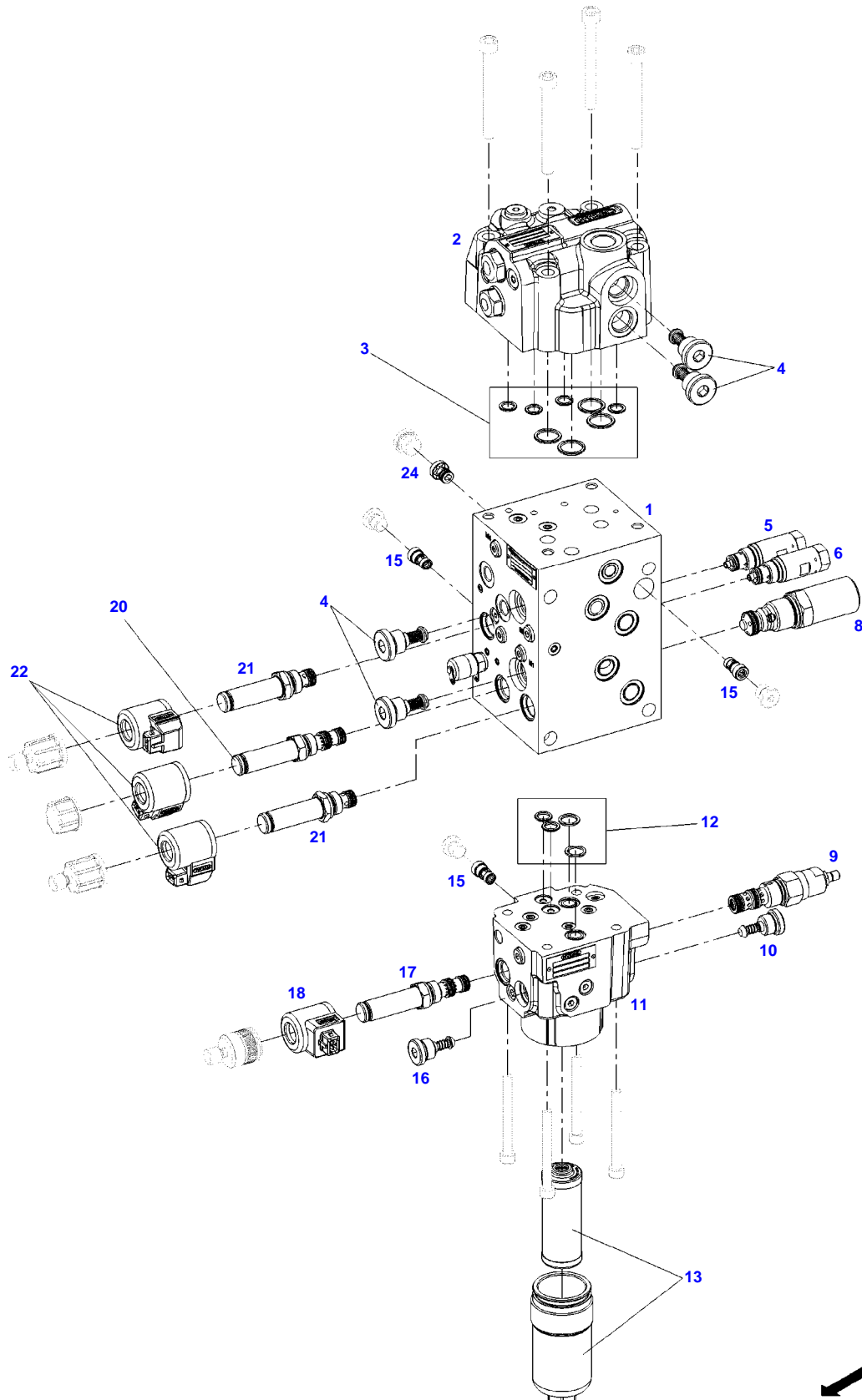

F061195



Item	Part Number	Qty	Description Comments	Technical Specification
			UP TO MACHINE S/N WAM530XXX00F05238	
1	72624023	1	VALVE BLOCK INCLUDES ITEMS 2-24	
2	72626279	1	PRESSURE MAINTENANCE VALVE	
3	72626280	1	SEAL KIT	
4	72476080	4	CHECK VALVE RVL1/2	
5	72455442	1	PRESSURE RELIEF VALVE DBVL	
	72317904	1	SEAL KIT DBVL	
6	72455496	1	PRESSURE RELIEF VALVE DBVF	
	72317904	1	SEAL KIT	
8	72317905	1	PRESSURE RELIEF VALVE DBV1	
	72317906	1	SEAL KIT	
9	72486199	1	PRESSURE CONTROL VALVE DRVP	
	72455011	1	SEAL KIT	
10	72476081	1	CHECK VALVE RVP1, NG10	
11	72626281	1	PRE-CONTROL UNIT KIT	
12	72626282	1	SEAL KIT	
13	72493246	1	HYDRAULIC FILTER	STEUERDRUCK
15	72317919	2	CHANGE VALVE WV1/5	
16	72476082	1	CHECK VALVE RV_DFP, NG10	
17	72455510	1	VALVE MVP	
	72438741	1	SEAL KIT	
18	72455511	1	MAGNET COIL	
20	72438731	1	VALVE MVL	
	72438741	1	SEAL KIT	
21	72486195	2	VALVE MVFH/MVFS	
	72438742	2	SEAL KIT	
22	72484293	3	MAGNET COIL	
24	72487209	1	CHECK VALVE RVF1	

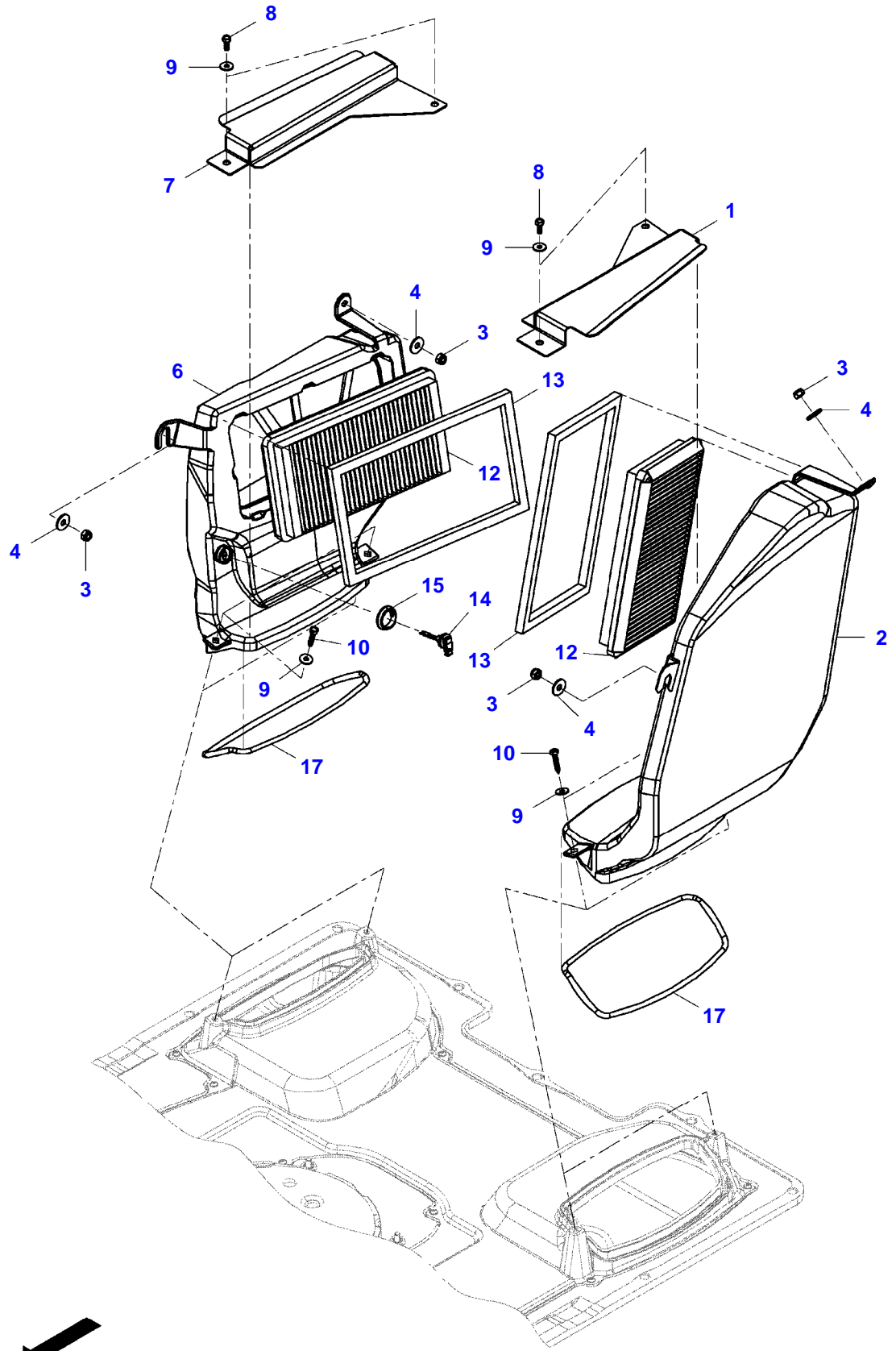

22871904-M-1

Item	Part Number	Qty	Description Comments	Technical Specification
1	72619770	1	COVER PANEL	
2	72619773	1	AIR FUNNEL	
3	72372950	4	NUT	DIN 985 M8-8A3L
4	72311824	4	DISC	DIN9021-8,4-140HV-A3L
6	72620538	1	AIR FUNNEL	
7	72619769	1	COVER PANEL	
8	72315815	4	SCREW	DIN7976-ST6,3X16-F-A3L
9	72311822	8	DISC	DIN9021-6,4-140HV-A3L
10	72424850	4	SCREW	DIN7976-ST6,3X32-C-A3L
12	72620539	2	FILTER CAB AIR RECIRCULATION	
13	72623408	2	GASKET	
14	72486861	1	SENSOR TEMPERATURE INSIDE	
15	72623219	1	GASKET	
17	72619759	2	GASKET	

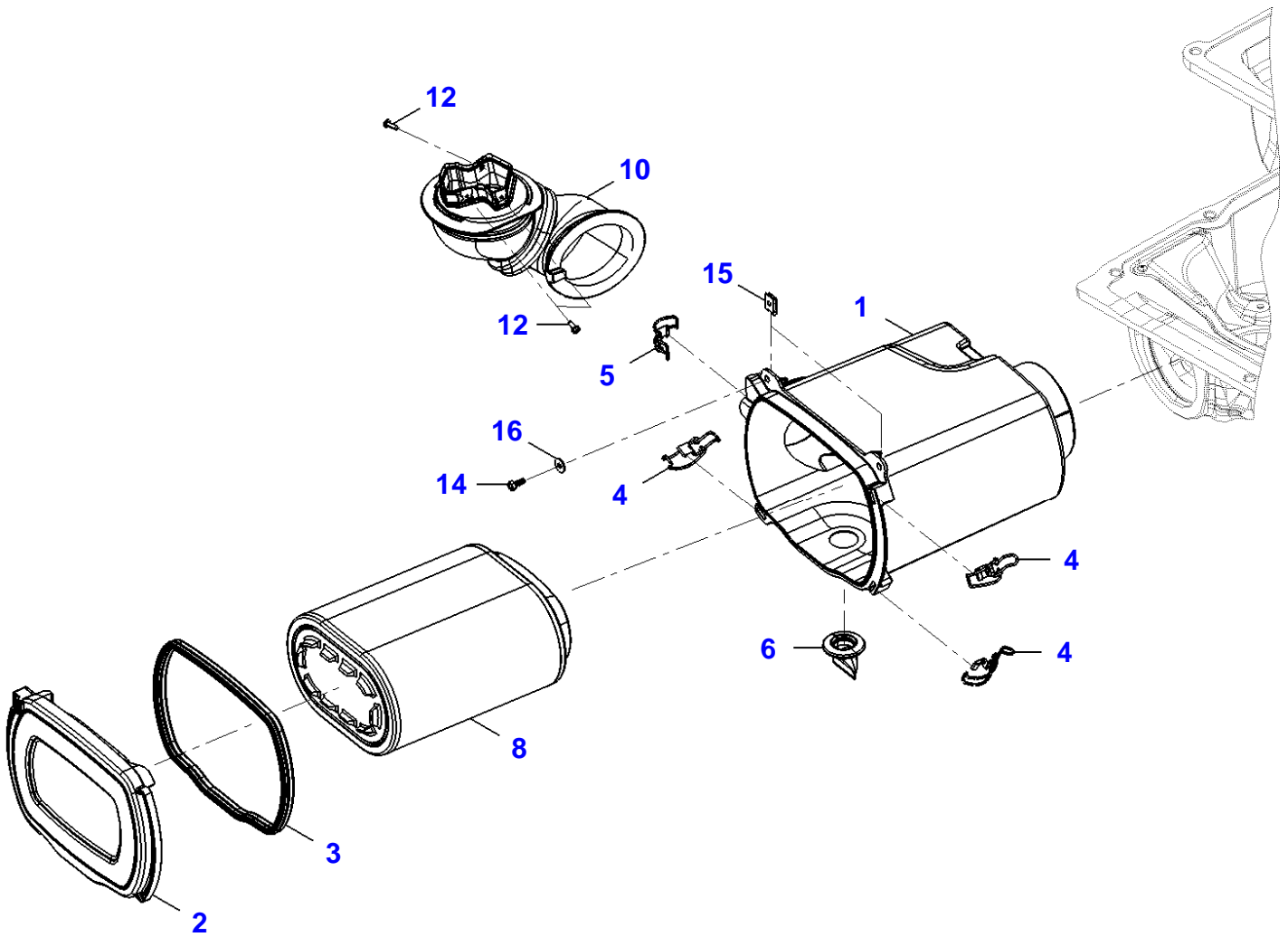

Item	Part Number	Qty	Description Comments	Technical Specification
1	72619775	1	HOUSING	
2	72619776	1	LID	
3	72621050	1	SEALING PROFILE 1X 765MM	L=1,970M-FWN63041_8
4	72620163	3	DRAW LATCH	
5	72620164	1	DRAW LATCH	
6	72490381	1	UNIVERSAL SPOUT	
8	72620540	1	FILTER CARTRIDGE	
10	72620156	1	RUBBER ARCH	
12	72455397	3	SCREW	F.BLECH ST4,8X16-F A3R
14	72315815	2	SCREW	DIN7976-ST6,3X16-F-A3L
15	72313338	2	SPEED NUT	6,3 MKB1
16	72311822	2	DISC	DIN9021-6,4-140HV-A3L

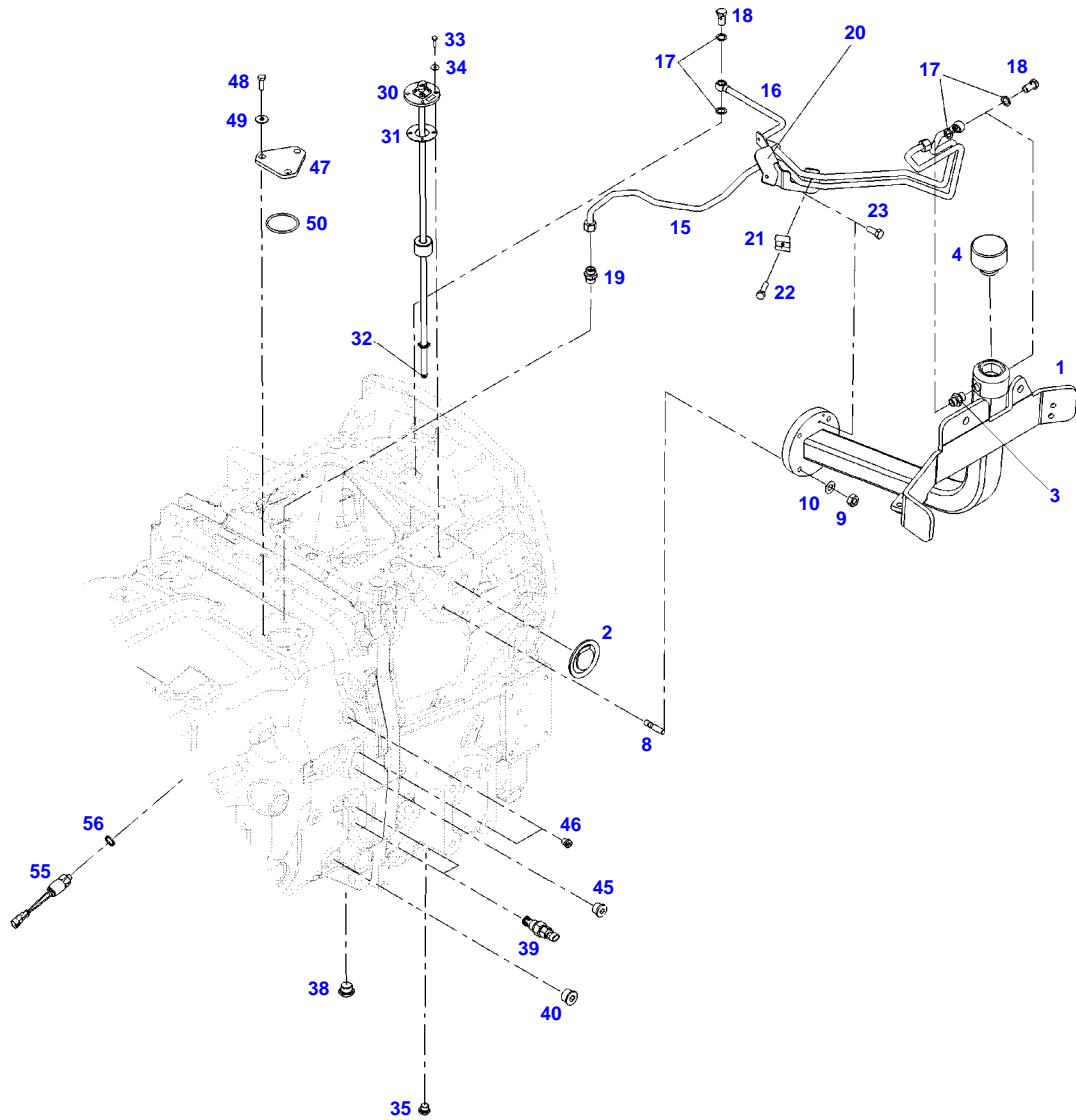

F061390





**Suggest:**

**For more complete manuals. Please go to the home page.**

**<https://www.ebooklibonline.com>**

**If the above button click is invalid. Please download this document first, and then click the above link to download the complete manual.**

**Thank you so much for reading**

Item	Part Number	Qty	Description Comments	Technical Specification
			<b>FROM - UP TO MACHINE S/N 530/1001 - 530/1284</b>	
1	72629563	1	FILLER ORDER ADDITIONAL	
	72629564	1	VENTILATION FILTER	HYDRAULIK
	72629565	1	SIEVE	
2	72623729	1	SEALING RUBBER	
3	72438330	1	SCREW NECK	FWN65925-L12-M18X1,5OMD-A3L 1
4	72364577	1	VENTILATION FILTER L1.0807-31	
8	72313777	4	STUD BOLT	DIN 939 M10X35-8.8
9	72313272	4	NUT	DIN 934 M10-8A3L
10	72317122	4	SPRING WASHER	DIN 137 B10-MECH.VZK
15	72624024	1	VENT TUBE	
16	72623688	1	VENT TUBE	
17	72608905	4	GASKETS	14X22X1,5
18	72315808	2	BANJO BOLT	DIN 7643-10-3-A3L
19	72438330	1	SCREW NECK	FWN65925-L12-M18X1,5OMD-A3L 1
20	72623638	1	HOLDER	
21	72311266	1	CLIP	
22	72315633	1	HEXAGONAL HEAD BOLT	DIN 933 M6X25-8.8A3L
23	72315626	2	HEXAGONAL HEAD BOLT	DIN 933-M6 X 16-8.8-A3L
30	72623127	1	FUEL TRANSMITTER INCLUDES ITEMS 31,32	
31	72476833	1	FLANGE WASHER	
32	72451977	1	O-RING	D9X2,5
33	72315619	4	HEXAGONAL HEAD BOLT	DIN 933 M5X16-8.8A3L
34	72311819	4	DISC	DIN9021-5,3-140HV-A3R
35	72478716	1	PLUG SCREW	DIN 908 M16X1,5-ED-A3L
38	72438052	1	PLUG SCREW	
39	72618272	2	FLOWMETER	
40	72317613	1	PLUG SCREW NOT USED AT REAR POWER LIFT	VSTIM22X1,5EDFPA3C
45	72317613	1	PLUG SCREW	VSTIM22X1,5EDFPA3C
46	72315449	2	PLUG SCREW NOT USED AT 2ND CIRCUIT HYDR. 1 X	FWN64838-M12X1,5-ED-FPM
47	72629560	1	PLATE NOT USED AT 2ND CIRCUIT HYDR.	
48	72315653	3	HEXAGONAL HEAD BOLT NOT USED AT 2ND CIRCUIT HYDR.	DIN 933 M8 X 25-8.8A3L
49	72311824	3	DISC NOT USED AT 2ND CIRCUIT HYDR.	DIN9021-8,4-140HV-A3L
50	72437222	1	O-RING NOT USED AT 2ND CIRCUIT HYDR.	60X4-NBR 70 FWN56402
55	72453413	1	PRESSURE SWITCH	
56	72315090	1	SEALING WASHER	DIN 7603 A12X15,5-CU

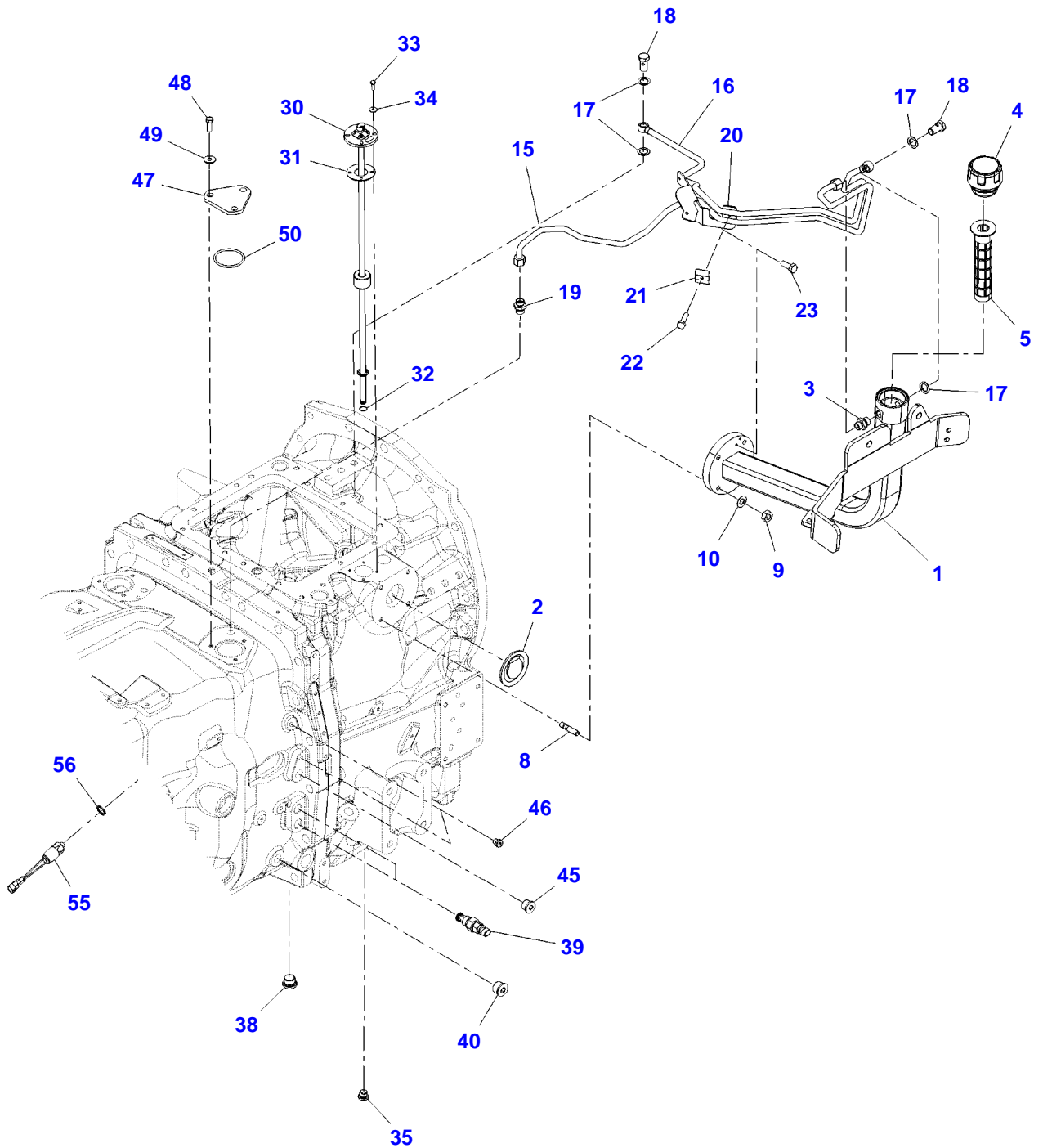

18114150-M-1

Item	Part Number	Qty	Description Comments	Technical Specification
			FROM MACHINE S/N 530/1285	
1	72629563	1	FILLER	
2	72623729	1	SEALING RUBBER	
3	72438330	1	SCREW NECK	FWN65925-L12-M18X1,5OMD-A3L 1
4	72629564	1	VENTILATION FILTER	HYDRAULIK
	72657543	1	O-RING	Ø 58,74X3,53
5	72629565	1	SIEVE	
8	72313777	4	STUD BOLT	DIN 939 M10X35-8.8
9	72313272	4	NUT	DIN 934 M10-8A3L
10	72317122	4	SPRING WASHER	DIN 137 B10-MECH.VZK
15	72624024	1	VENT TUBE	
16	72623688	1	VENT TUBE	
17	72608905	4	GASKETS	14X22X1,5
18	72315808	2	BANJO BOLT	DIN 7643-10-3-A3L
19	72438330	1	SCREW NECK	FWN65925-L12-M18X1,5OMD-A3L 1
20	72623638	1	HOLDER	
21	72311266	1	CLIP	
22	72315633	1	HEXAGONAL HEAD BOLT	DIN 933 M6X25-8.8A3L
23	72315626	2	HEXAGONAL HEAD BOLT	DIN 933-M6 X 16-8.8-A3L
30	72623127	1	FUEL TRANSMITTER INCLUDES ITEMS 31,32	
31	72476833	1	FLANGE WASHER	
32	72451977	1	O-RING	D9X2,5
33	72315619	4	HEXAGONAL HEAD BOLT	DIN 933 M5X16-8.8A3L
34	72311819	4	DISC	DIN9021-5,3-140HV-A3R
35	72478716	1	PLUG SCREW	DIN 908 M16X1,5-ED-A3L
38	72438052	1	PLUG SCREW	
39	72618272	2	FLOWMETER	
40	72317613	1	PLUG SCREW NOT USED AT REAR POWER LIFT	VSTIM22X1,5EDFPMA3C
45	72317613	1	PLUG SCREW	VSTIM22X1,5EDFPMA3C
46	72315449	2	PLUG SCREW NOT USED AT 2ND CIRCUIT HYDR. 1 X	FWN64838-M12X1,5-ED-FPM
47	72629560	1	PLATE NOT USED AT 2ND CIRCUIT HYDR.	
48	72315653	3	HEXAGONAL HEAD BOLT NOT USED AT 2ND CIRCUIT HYDR.	DIN 933 M8 X 25-8.8A3L
49	72311824	3	DISC NOT USED AT 2ND CIRCUIT HYDR.	DIN9021-8,4-140HV-A3L
50	72437222	1	O-RING NOT USED AT 2ND CIRCUIT HYDR.	60X4-NBR 70 FWN56402
55	72453413	1	PRESSURE SWITCH	
56	72315090	1	SEALING WASHER	DIN 7603 A12X15,5-CU

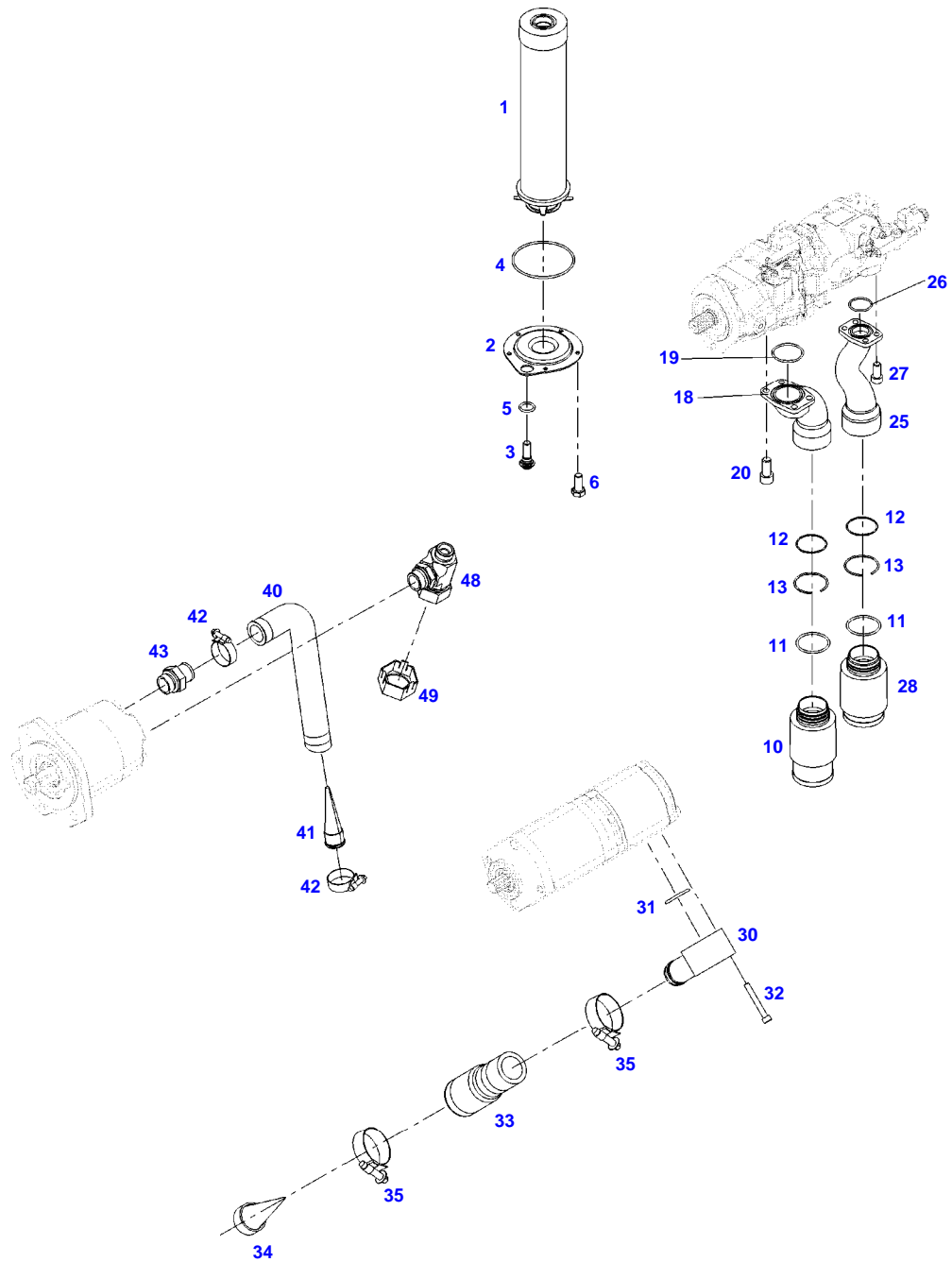

F061011



**<https://www.ebooklibonline.com>**

Hello dear friend!

Thank you very much for reading.

Enter the link into your browser.

The full manual is available for immediate download.

**<https://www.ebooklibonline.com>**