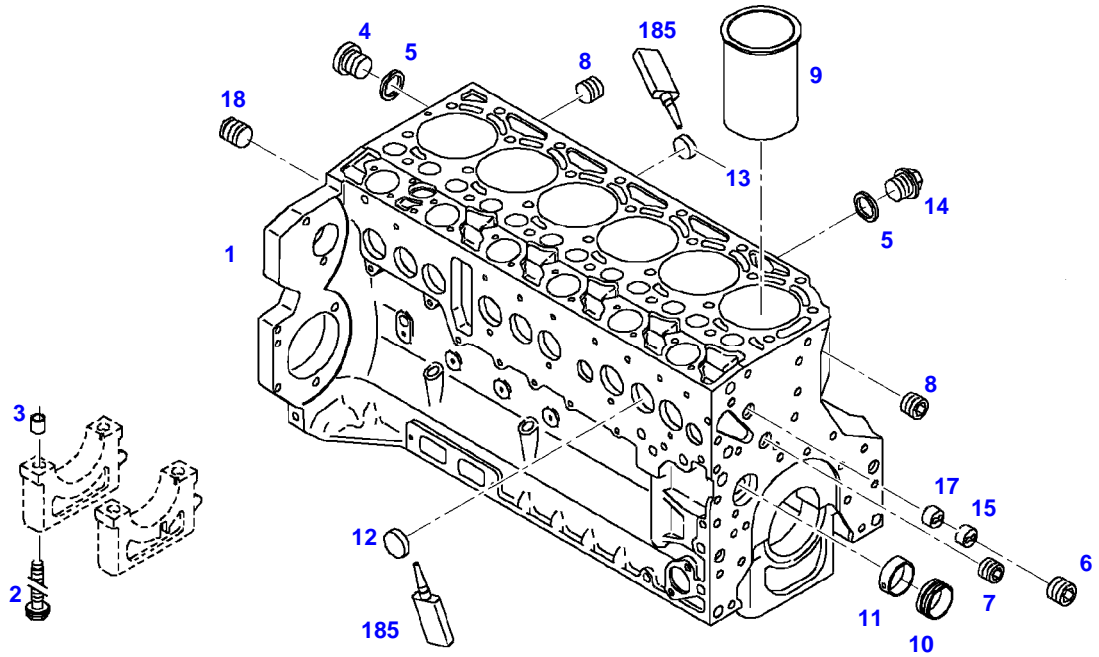

TABLE OF CONTENT

Page Number	Page Title	Page Reference
01-000-TOC	ENGINE, FUEL AND EXHAUST SYSTEM	01-000-TOC
02-000-TOC	AXLES	02-000-TOC
03-000-TOC	STEERING SYSTEM	03-000-TOC
04-000-TOC	DRIVE TRAIN SYSTEM	04-000-TOC
05-000-TOC	COMPRESSED AIR SYSTEM	05-000-TOC
06-000-TOC	HYDRAULIC SYSTEM	06-000-TOC
07-000-TOC	ELECTRICAL SYSTEM	07-000-TOC
08-000-TOC	CAB	08-000-TOC
09-000-TOC	AIR CONDITIONING AND HEATING SYSTEM	09-000-TOC
10-000-TOC	CHASSIS	10-000-TOC
11-000-TOC	WHEELS	11-000-TOC
12-000-TOC	IMPLEMENT LIFT SYSTEM FRONT	12-000-TOC
13-000-TOC	IMPLEMENT LIFT SYSTEM REAR	13-000-TOC
14-000-TOC	FRONT/REAR LOADERS	14-000-TOC
15-000-TOC	ACCESSORIES	15-000-TOC

FENDT 817NA (717/00101-99999)
35077



035077

Item	Part Number	Qty	Description Comments	Technical Specification
			ENGINE NUMBER --> 1054149 <-- 1054152 --> 1059467	
	72434312	1	ENGINE ENGINE NEW FLYWHEEL MUST BE CHANGED IF A NEW ENGINE IS SUPPLIED <-- Z717.200.010.011 ENGINE EXCHANGE	BF06M2013C
1	72604532	1	REMANUFACTURED SHORT BLOCK ENGINE	
	72429392	1	CRANKCASE ><2-15,17,18 <-- F718.202.210.210	
2	72416467	14	HEXAGONAL HEAD BOLT	
3	72344342	14	ADAPTER BUSH	
4	72315438	1	PLUG SCREW	DIN 908 M14X1,5-ST
5	72315095	3	SEALING WASHER	DIN 7603 A14X20-CU
6	72325319	1	PLUG M30X1,5	
7	72325321	1	PLUG N22X1,5	
8	72429347	2	SCREW M14X1,5	M14X1,5
9	72416468	6	CYLINDER LINER	
10	72416469	6	BEARING BUSHING	
11	72416470	1	BEARING BUSHING	
12	72325325	9	CORE HOLE PLUG	
13	72325326	6	CORE HOLE PLUG	
14	72315799	2	PLUG	DIN 7604 AM14X1,5-A3L
15	72325327	1	GUIDE SLEEVE	
17	72415819	1	GUIDE SLEEVE	
18	72431135	1	LOCKING PLUG M22X1,5	
185	72381391	1	THREADLOCKER	LOCTITE 243 10ML

<https://www.ebooklibonline.com>

Hello dear friend!

Thank you very much for reading.

Enter the link into your browser.

The full manual is available for immediate download.

<https://www.ebooklibonline.com>

FENDT 817NA (717/00101-99999)
41012



041012

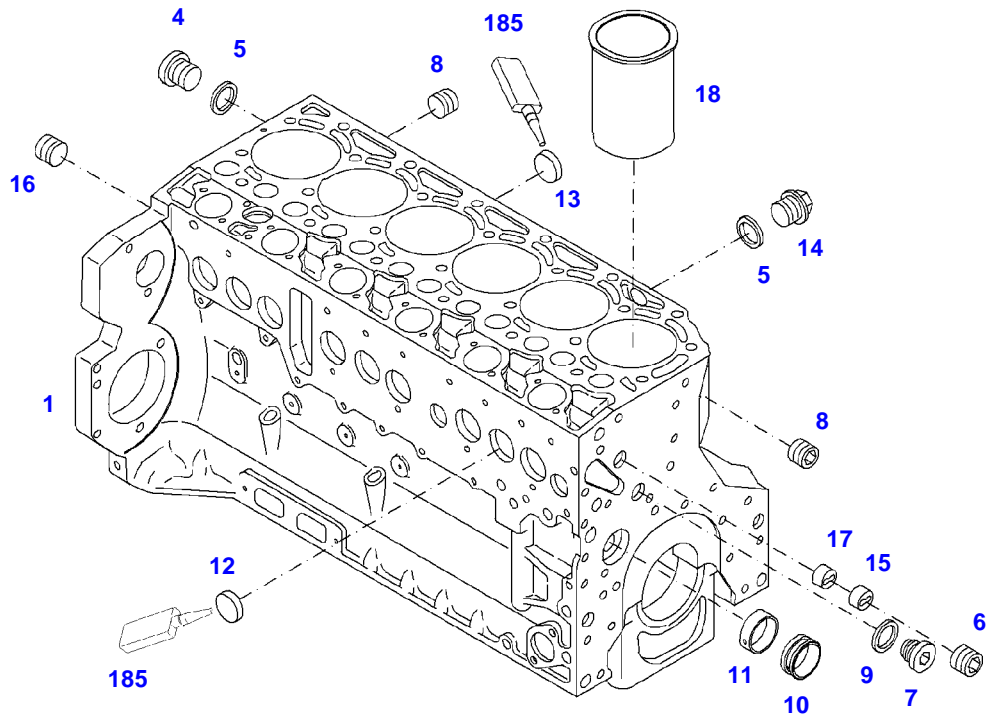

Item	Part Number	Qty	Description Comments	Technical Specification
			ENGINE NUMBER <-- 1054150 --> 1054151 <-- 1059468	
	72434312	1	ENGINE ENGINE NEW FLYWHEEL MUST BE CHANGED IF A NEW ENGINE IS SUPPLIED --> 717/2140 <-- Z717.200.010.011 ENGINE EXCHANGE	BF06M2013C
	72604532	1	REMANUFACTURED SHORT BLOCK ENGINE --> 717/2140	
	72451219	1	ENGINE ENGINE NEW FLYWHEEL MUST BE CHANGED IF A NEW ENGINE IS SUPPLIED <-- 717/2141 --> 717/2172 <-- Z717.200.010.012 ENGINE EXCHANGE	BF06M2013C
	72604532	1	REMANUFACTURED SHORT BLOCK ENGINE <-- 717/2141 --> 714/2172	
	72451256	1	ENGINE ENGINE NEW <-- 717/2173 <-- Z717.200.010.013 ENGINE EXCHANGE	BF06M2013C
	72604532	1	REMANUFACTURED SHORT BLOCK ENGINE <-- 717/2173	
1	72497864	1	CRANKCASE ><2-18 SERIES EXECUTION NO LONGER AVAILABLE	
	72616648	1	CRANKCASE SUPERSESION	
2	72416467	14	HEXAGONAL HEAD BOLT	
3	72344342	14	ADAPTER BUSH	
4	72315438	1	PLUG SCREW	DIN 908 M14X1,5-ST
5	72315095	3	SEALING WASHER	DIN 7603 A14X20-CU
6	72325319	1	PLUG M30X1,5	
7	72325321	1	PLUG N22X1,5 ENG.NO. --> 10540188	
	72455559	1	PLUG SCREW ENG.NO. <-- 10540189	
8	72429347	2	SCREW M14X1,5	M14X1,5
9			NOT USED --> 10540188	
	72455567	1	SEALING WASHER ENG.NO. <-- 10540189	DIN 7603 D22X27-CU
10	72416469	6	BEARING BUSHING	
11	72416470	1	BEARING BUSHING	
12	72325325	9	CORE HOLE PLUG	
13	72325326	6	CORE HOLE PLUG	
14	72315799	2	PLUG	DIN 7604 AM14X1,5-A3L

Fendt

FENDT 817NA (717/00101-99999)

F717105

CRANKCASE

Page01-0002

Item	Part Number	Qty	Description Comments	Technical Specification
15	72325327	1	GUIDE SLEEVE	
16	72431135	1	LOCKING PLUG M22X1,5	
17	72415819	1	GUIDE SLEEVE	
18	72451321	6	CYLINDER LINER	
185	72381391	1	THREADLOCKER	LOCTITE 243 10ML

FENDT 817NA (717/00101-99999)
432327-M-1

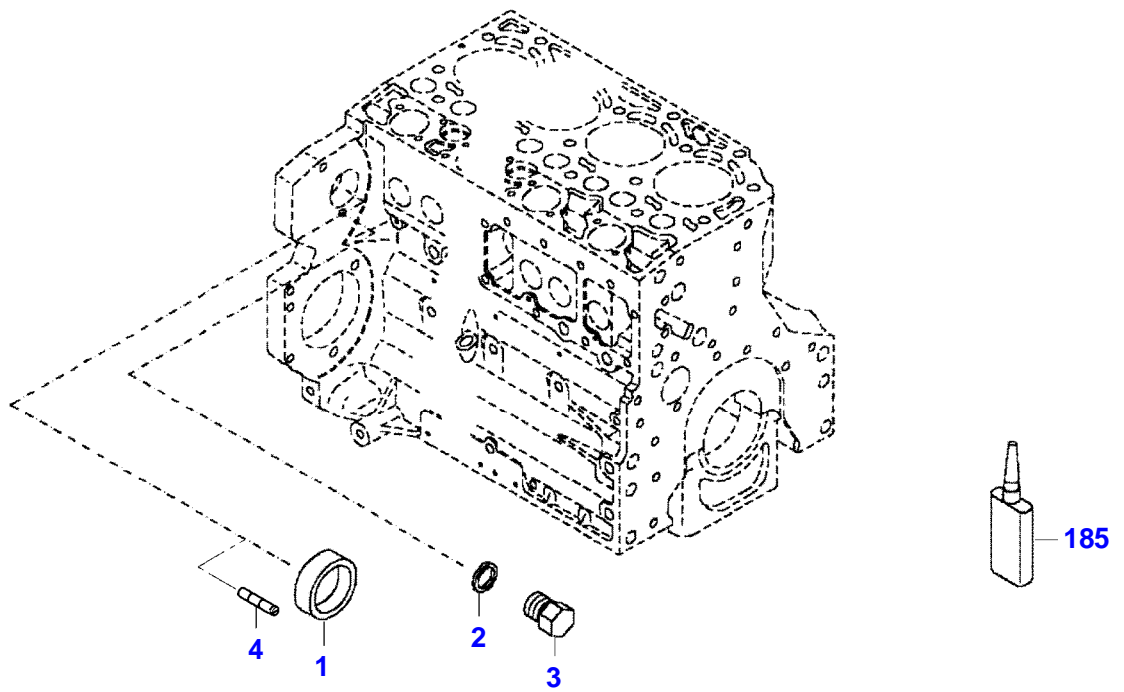

432327-M-1

Fendt

FENDT 817NA (717/00101-99999)

F717105

CRANKCASE

Page01-0003

Item	Part Number	Qty	Description Comments	Technical Specification
BLANKING PARTS				
1	72627515	1	CORE HOLE PLUG	
2	72315088	2	SEALING WASHER	DIN 7603 A10X13,5-CU
3	72323677	2	PLUG	
4	72631860	2	SLUG	
185	72325403	1	SAFE.LOCK AGENT	

FENDT 817NA (717/00101-99999)
30094

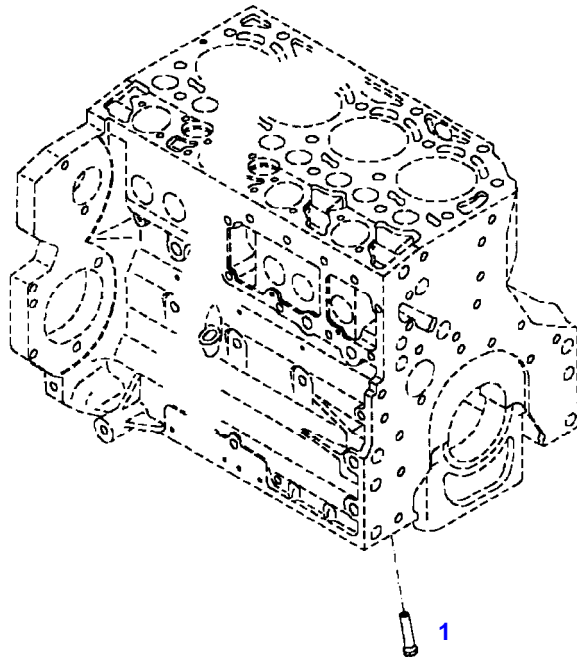

030004

Fendt

FENDT 817NA (717/00101-99999)

F717105

CRANKCASE

Page01-0004

Item	Part Number	Qty	Description Comments
			PISTON COOL.NOZZLE
1	72415140	6	PISTON COOLING JET

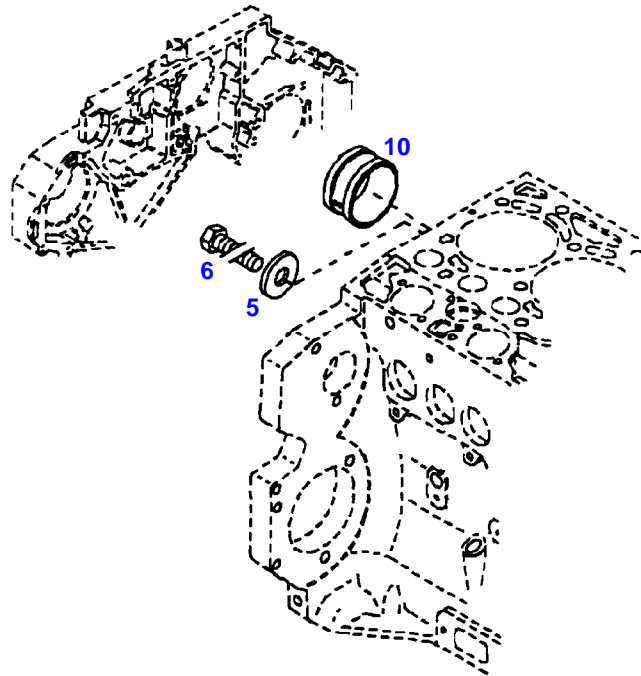

12574

Fendt

FENDT 817NA (717/00101-99999)

F717105

CRANKCASE

Page01-0005

Item	Part Number	Qty	Description Comments
BLANKING PARTS			
5	72415828	1	DISC
6	72426697	1	HEXAGONAL HEAD BOLT
10	72426698	1	BUSH

FENDT 817NA (717/00101-99999)
40194

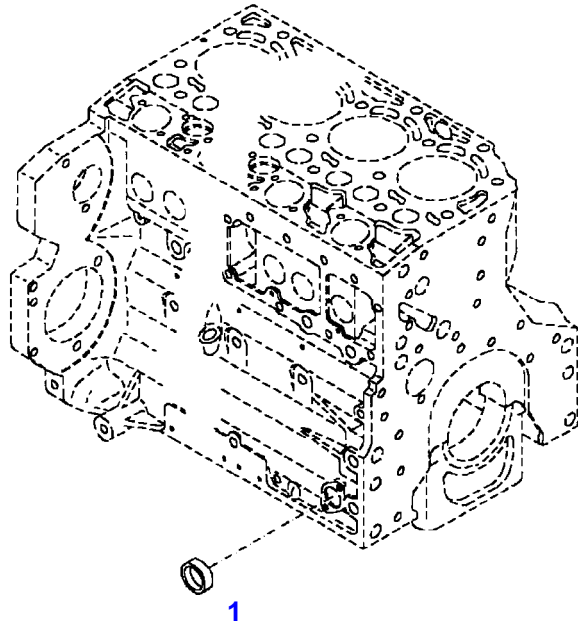

040194

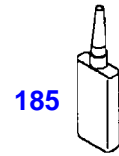

Fendt

FENDT 817NA (717/00101-99999)

F717105

CRANKCASE

Page01-0006

Item	Part Number	Qty	Description Comments
			LOCKING PLUG
1	72325326	1	CORE HOLE PLUG
185	72325403	1	SAFE.LOCK AGENT

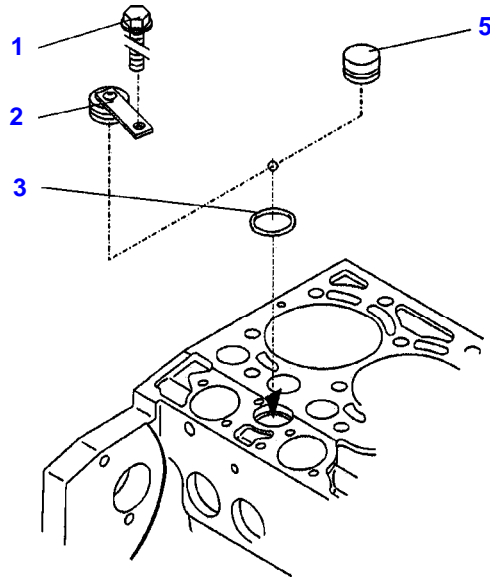

040896

Item	Part Number	Qty	Description Comments
			BLANKING PARTS ENGINE NUMBER --> 10059473
1	72433726	1	WASHER HEAD BOLT
2	72433725	1	LOCKING PART ><3
3	72325392	1	SEAL 26X3MM
5	72426700	1	LOCKING PLUG <-- F718.202.210.110 1X <>
	72433726	1	WASHER HEAD BOLT

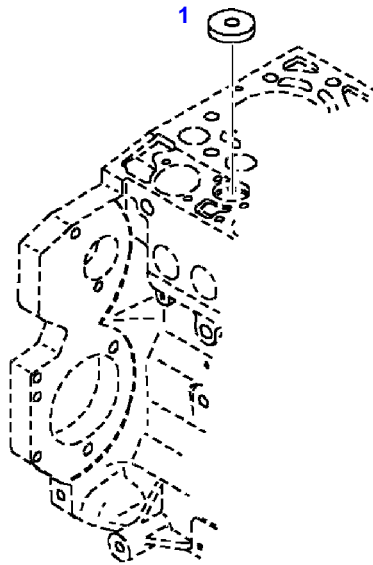

035132

Fendt

FENDT 817NA (717/00101-99999)

F717105

CRANKCASE

Page01-0008

Item	Part Number	Qty	Description Comments
			BLANKING PARTS ENGINE NUMBER <-- 10059474
1	72451322	1	COVER

FENDT 817NA (717/00101-99999)
F51551

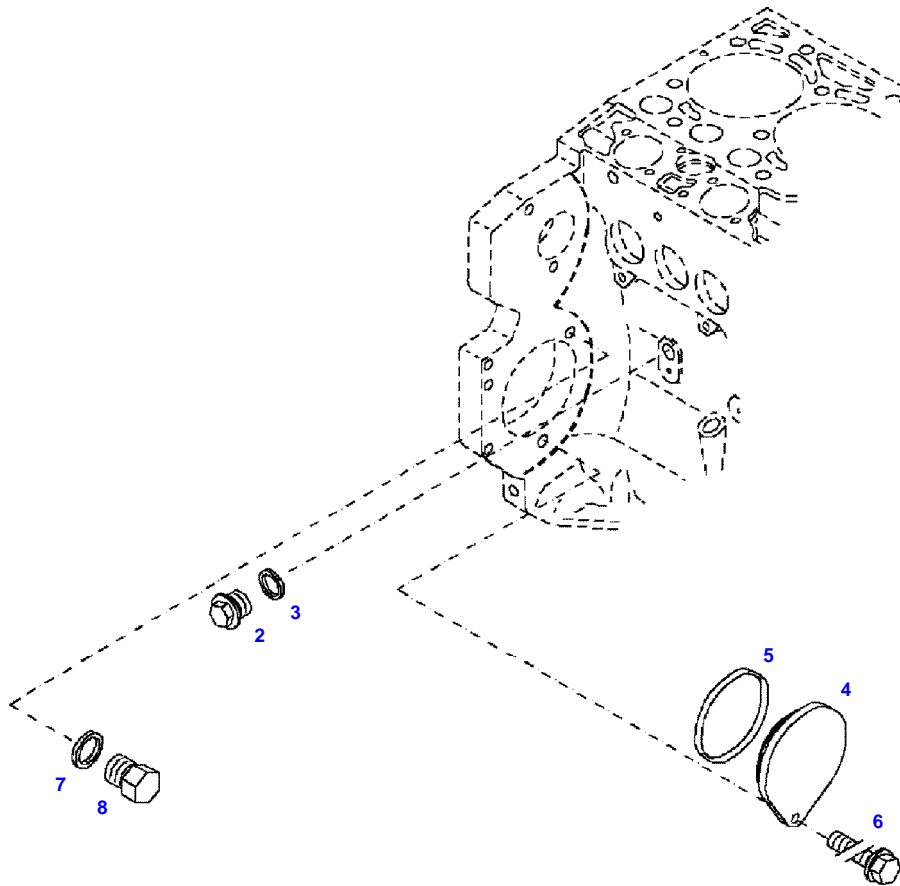

051551



Item	Part Number	Qty	Description Comments	Technical Specification
			BLANKING PARTS ENGINE NUMBER --> 829319	
2	72315799	1	PLUG NOT NEEDED WITH AIR BRAKE	DIN 7604 AM14X1,5-A3L
3	72315094	1	SEALING WASHER NOT NEEDED WITH AIR BRAKE	DIN 7603 A14X18-CU
4	72431648	1	COVER NOT NEEDED WITH AIR BRAKE	
5	72416472	1	SEAL 96X4MM NOT NEEDED WITH AIR BRAKE	
6	72621034	1	HEXAGONAL HEAD BOLT NOT NEEDED WITH AIR BRAKE	M10X20
7	72315088	1	SEALING WASHER	DIN 7603 A10X13,5-CU
8	72323677	1	PLUG	

FENDT 817NA (717/00101-99999)
F51552

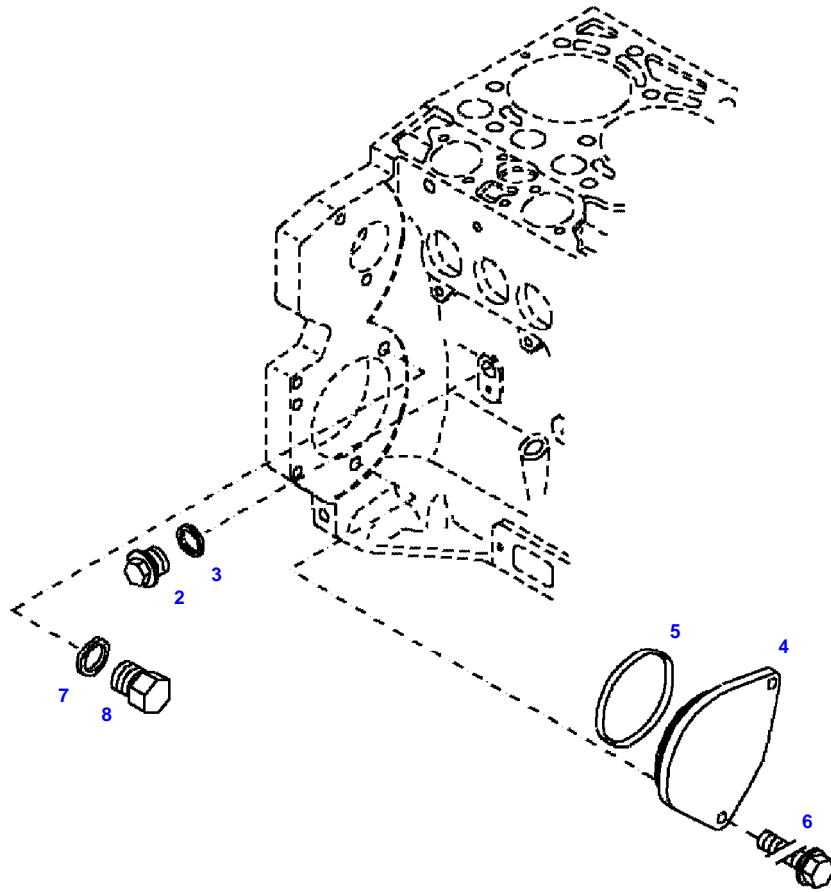

051552



Item	Part Number	Qty	Description Comments	Technical Specification
			BLANKING PARTS ENGINE NUMBER <-- 829320	
2	72315799	1	PLUG NOT NEEDED WITH AIR BRAKE	DIN 7604 AM14X1,5-A3L
3	72315094	1	SEALING WASHER NOT NEEDED WITH AIR BRAKE	DIN 7603 A14X18-CU
4	72431648	1	COVER NOT NEEDED WITH AIR BRAKE	
5	72416472	1	SEAL 96X4MM NOT NEEDED WITH AIR BRAKE	
6	72621034	2	HEXAGONAL HEAD BOLT NOT NEEDED WITH AIR BRAKE	M10X20
7	72315088	1	SEALING WASHER	DIN 7603 A10X13,5-CU
8	72323677	1	PLUG	

FENDT 817NA (717/00101-99999)
40029

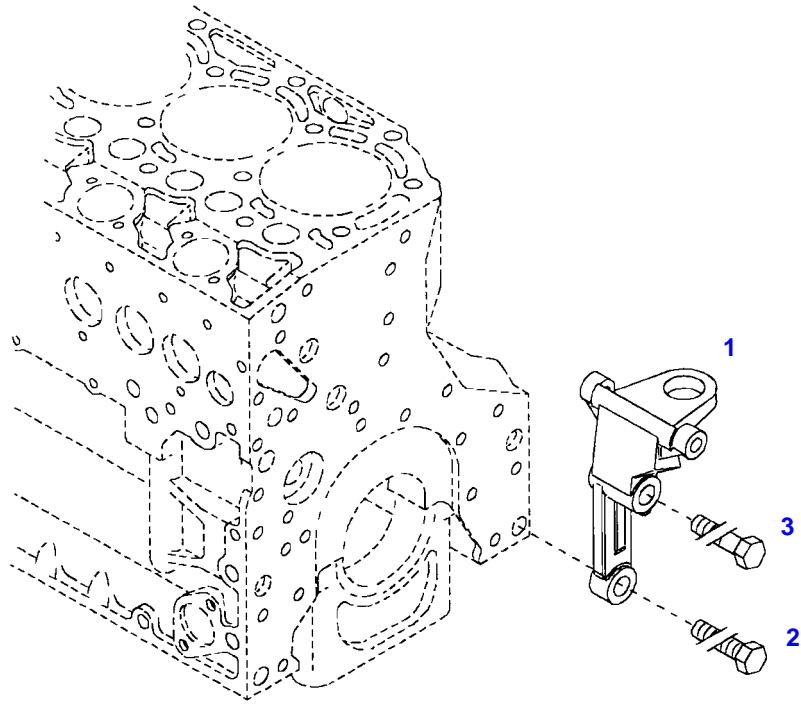

040029

Fendt

FENDT 817NA (717/00101-99999)

F717105

ENGINE MOUNTINGS

Page01-0011

Item	Part Number	Qty	Description Comments	Technical Specification
			LEFT	
1	72428791	1	ENGINE SUSPENSION	
2	72418408	1	HEXAGONAL HEAD BOLT	DIN 933 M16X40 GWA-10.9
3	72374294	1	HEXAGONAL HEAD BOLT	DIN 931-M16X85 GWA-10.9

FENDT 817NA (717/00101-99999)
40030

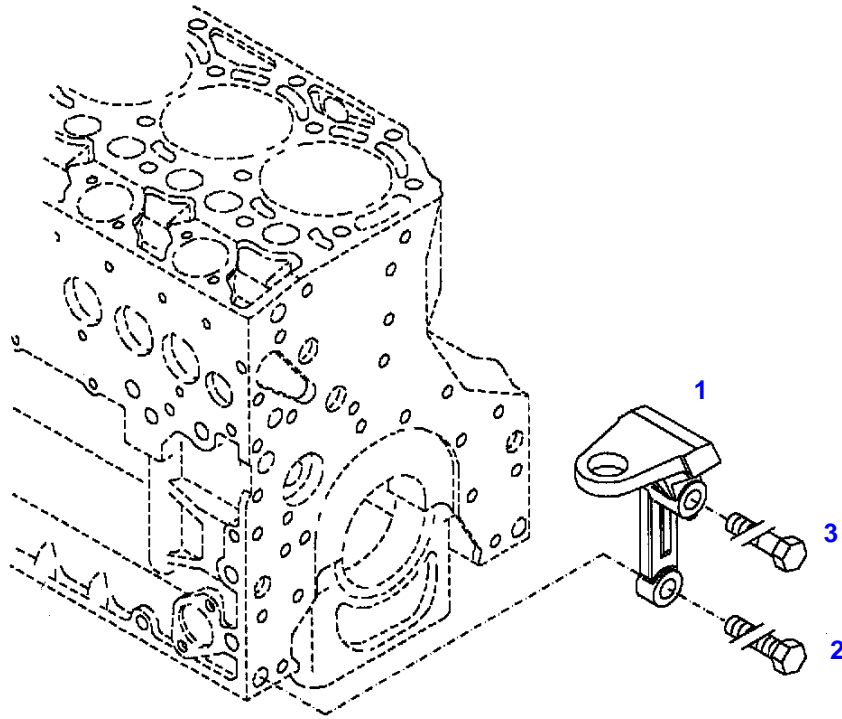

040030

Fendt

FENDT 817NA (717/00101-99999)

F717105

ENGINE MOUNTINGS

Page01-0012

Item	Part Number	Qty	Description Comments	Technical Specification
			RIGHT	
1	72423955	1	ENGINE SUSPENSION	
2	72418408	1	HEXAGONAL HEAD BOLT	DIN 933 M16X40 GWA-10.9
3	72374294	1	HEXAGONAL HEAD BOLT	DIN 931-M16X85 GWA-10.9

FENDT 817NA (717/00101-99999)
35107

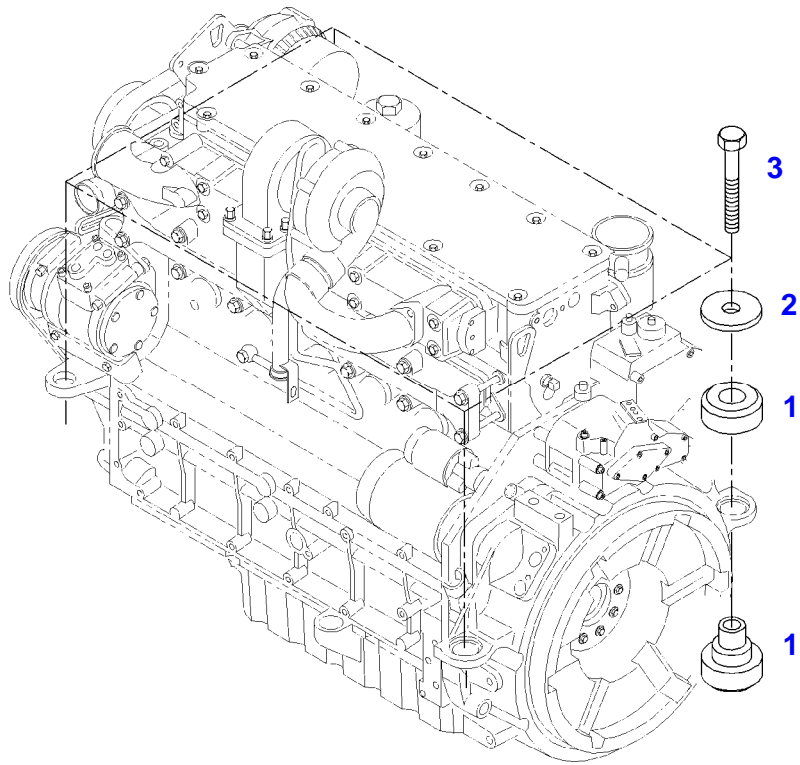

035107

Fendt

FENDT 817NA (717/00101-99999)

F717105

ENGINE BEARINGS

Page01-0013

Item	Part Number	Qty	Description Comments	Technical Specification
1	72423991	4	ENGINE MOUNT	
2	72318110	4	DISC	
3	72315563	4	HEXAGONAL HEAD BOLT	DIN 931 M12X80-8.8A3L

Item	Part Number	Qty	Description Comments	Technical Specification
1	72426699	1	BREATHER ><4-6 ENG.NO. --> 1002634	
	72434609	1	BREATHER WITHOUT SERVICEABLE FILTER ><4,6 <-- 1002635	
2	72325449	2	HEXAGONAL HEAD BOLT M8X25	M8X25
4	72416500	1	MOLDED SEAL	
5	72426653	1	FILTER ELEMENT ENG.NO. --> 1002634	
			NOT AVAILABLE IN SINGLE PARTS ENG.NO. <-- 1002635	
6	72425768	2	HEXAGONAL HEAD BOLT M5X20	
7	72325537	2	HOSE CLIP	
8	72425769	1	THIMBLE	
9	72315101	1	SEALING WASHER	DIN 7603 A22X27-CU
10	72425770	1	LOCK VALVE	
11	72325453	1	HEXAGONAL HEAD BOLT M8X50	
12	72325457	1	HEXAGONAL HEAD BOLT M8X40	
13	72425771	1	BREATHER LINE ><14-16	
14	72416578	2	SEALING WASHER	
15	72323517	1	BANJO BOLT	
16	72425772	2	PIPE CLAMP	

FENDT 817NA (717/00101-99999)
30399

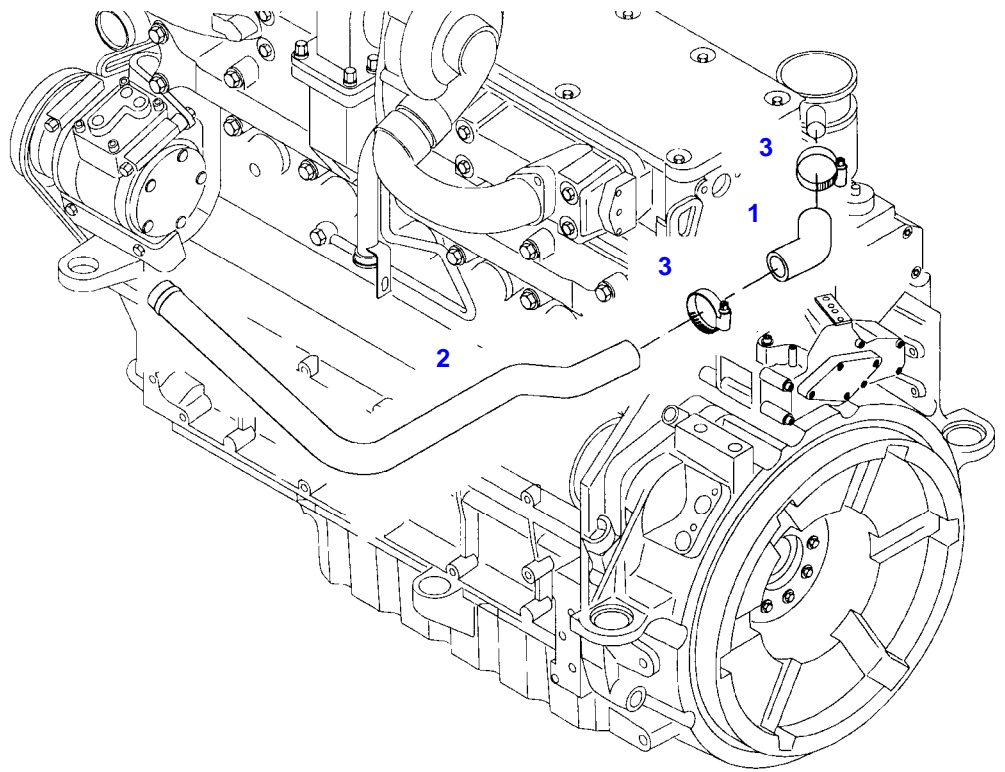

6660E0

Fendt

FENDT 817NA (717/00101-99999)

F717105

CRANKCASE BREATHER

Page01-0015

Item	Part Number	Qty	Description Comments
			PIPE
1	72318111	1	RUBBER ARCH
2	72318112	1	PIPE
3	72311167	2	HOSE CLIP

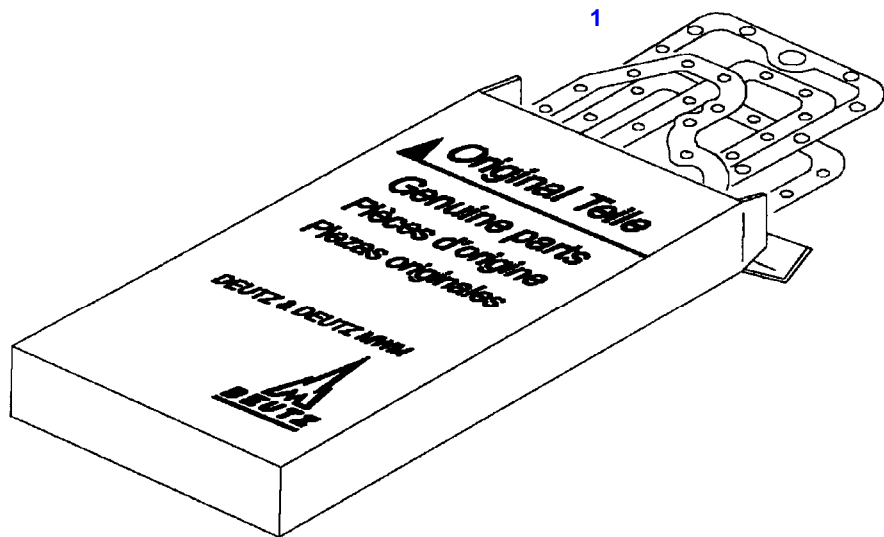

030100

Fendt

FENDT 817NA (717/00101-99999)

F717105

SET OF GASKETS

Page01-0016

Item	Part Number	Qty	Description Comments
			ENGINE
1	72487673	1	SEAL KIT WITHOUT CYLINDER HEAD GASKET

FENDT 817NA (717/00101-99999)
40475

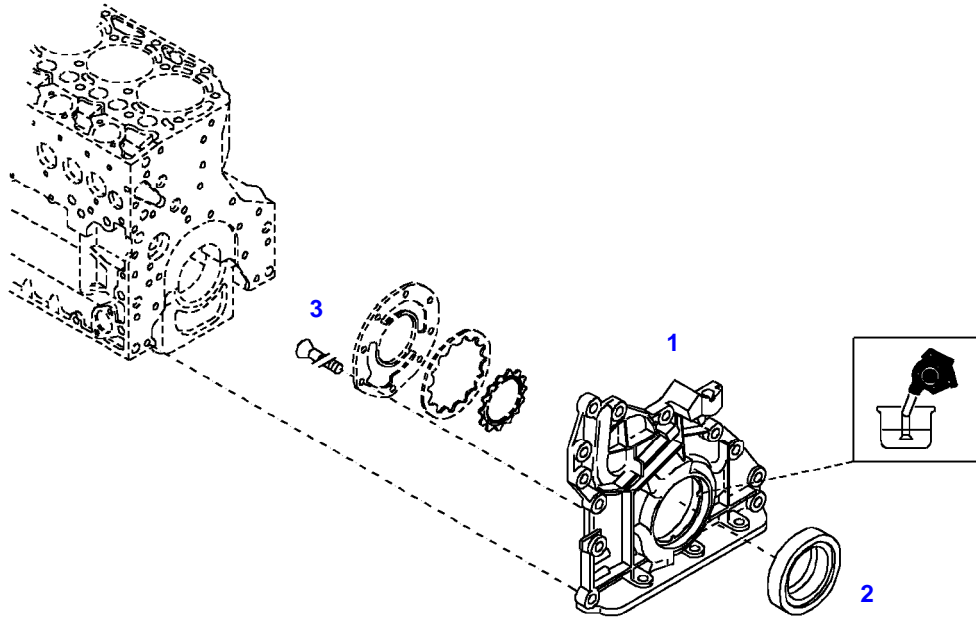

040475



Suggest:

For more complete manuals. Please go to the home page.

<https://www.ebooklibonline.com>

If the above button click is invalid. Please download this document first, and then click the above link to download the complete manual.

Thank you so much for reading

Fendt

FENDT 817NA (717/00101-99999)

F717105

FRONT COVER

Page01-0017

Item	Part Number	Qty	Description Comments
			INTEGRATED OIL PUMP
1	72479485	1	CRANKCASE END COVER INTEGRATED OIL PUMP ><2,3
2	72479487	1	SHAFT SEAL
3	72416228	8	COUNTERSUNK CAPSCREW M8X16

FENDT 817NA (717/00101-99999)
41308

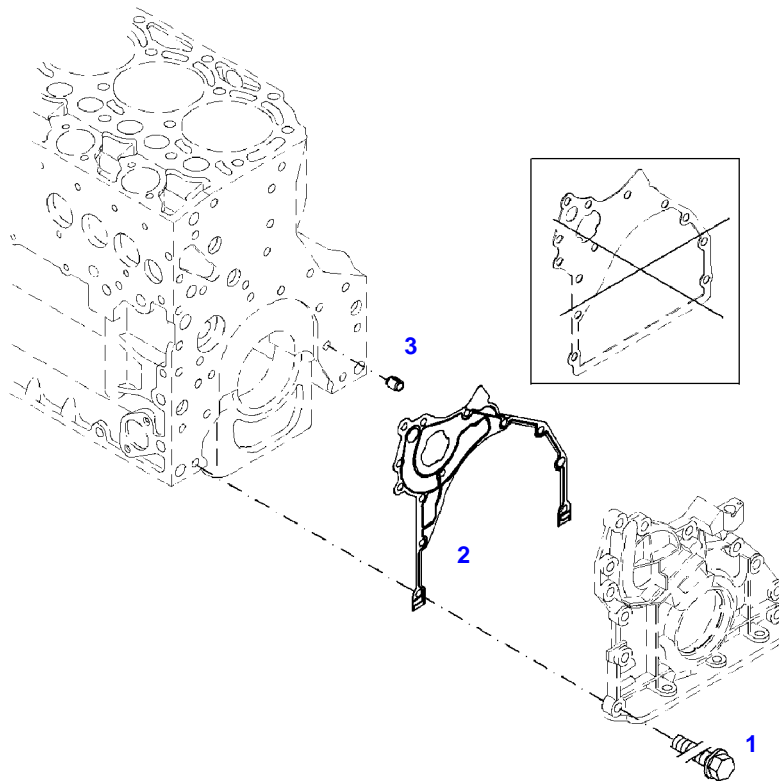

041308

<https://www.ebooklibonline.com>

Hello dear friend!

Thank you very much for reading.

Enter the link into your browser.

The full manual is available for immediate download.

<https://www.ebooklibonline.com>