

Page Number	Page Title	Page Reference
01-000-TOC	ENGINE, FUEL AND EXHAUST SYSTEM	01-000-TOC
02-000-TOC	AXLES	02-000-TOC
03-000-TOC	STEERING SYSTEM	03-000-TOC
04-000-TOC	DRIVE TRAIN SYSTEM	04-000-TOC
05-000-TOC	BRAKE SYSTEM	05-000-TOC
06-000-TOC	HYDRAULIC SYSTEM	06-000-TOC
07-000-TOC	ELECTRICAL SYSTEM	07-000-TOC
08-000-TOC	CAB	08-000-TOC
09-000-TOC	AIR CONDITIONING AND HEATING SYSTEM	09-000-TOC
10-000-TOC	CHASSIS	10-000-TOC
11-000-TOC	DECALS	11-000-TOC
12-000-TOC	WHEELS	12-000-TOC
13-000-TOC	IMPLEMENT DRIVE SYSTEM	13-000-TOC
14-000-TOC	IMPLEMENT LIFT SYSTEM REAR	14-000-TOC
15-000-TOC	FRONT/REAR LOADERS	15-000-TOC
16-000-TOC	PRECISION FARMING SYSTEMS	16-000-TOC
17-000-TOC	ATTACHMENTS	17-000-TOC
18-000-TOC	GENERAL INFORMATION	18-000-TOC

Page Number	Page Title	Page Reference
01-0001	CYLINDERBLOCK	1712698
01-0002	FLYWHEEL AND HOUSING	21-04
01-0003	CYLINDER HEAD	1715128
01-0004	VALVE MECHANISM	21-08
01-0005	CRANK MECHANISM	21-10
01-0006	BALANCER WEIGHT	21-12
01-0007	GEAR HOUSING	21-14
01-0008	OIL FILTER	21-16
01-0009	OIL SUMP	21-18
01-0010	AIR CLEANER	21-20
01-0011	INTAKE- AND EXHAUST PIPE	1710392
01-0012	INTERCOOLER	21-24
01-0013	EXHAUST PIPE	21-26
01-0014	TURBOCHARGER	1710395
01-0015	FUEL FILTER	22-02
01-0016	FUEL PIPES	22-04
01-0017	INJECTION PUMP	22-06
01-0018	SPEED LEVERS	1710402
01-0019	RADIATOR	23-02
01-0020	COOLANT PUMP	23-04
01-0021	STARTERMOTOR -P6276 (M)	24-02
01-0022	STARTERMOTOR P6277- (M)	1710418
01-0023	ALTERNATOR	24-04
01-0024	WIRING SET, ENGINE	24-06
01-0025	GASKET SETS	28-02
01-0026	ENGINE REPAIR KIT AND BEARING	28-04
01-0027	ADJUSTING PLATE FOR INJECTOR	28-06
01-0028	ENGINE HEATER (OPTIONAL EQUIPMENT)	29-02

XM150 TRACTOR (XM SERIES)
SPIMG-011-21-02

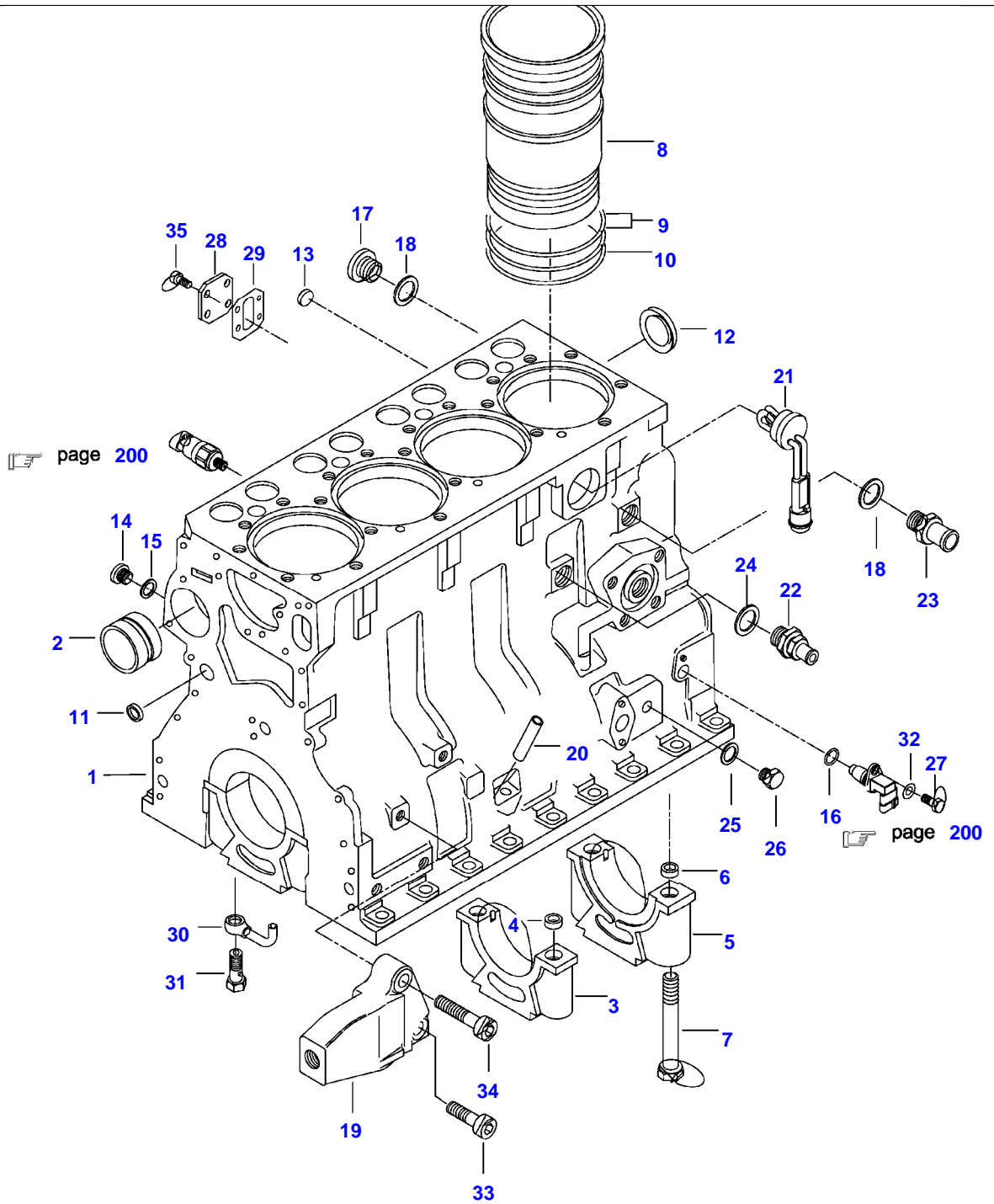

<https://www.ebooklibonline.com>

Hello dear friend!

Thank you very much for reading.

Enter the link into your browser.

The full manual is available for immediate download.

<https://www.ebooklibonline.com>

Item	Part Number	Qty	Description Comments
1	V836766377	1	CYLINDER BLOCK
2	V836866069	1	CAMSHAFT BEARING BUSHING
3	NS	4	NON-SERVICEABLE PART
4	V836214478	8	BEARING COVER GUIDE SLEEVE
5	NS	1	NON-SERVICEABLE PART
6	V836214478	2	BEARING COVER GUIDE SLEEVE
7	V835329030	10	HEX CAP SCREW
8	V836666990	4	LINER
9	V836647502	8	CYLINDER LINER O-RING S2
10	V836647503	4	CYLINDER LINER O-RING S2
11	V640016016	4	CUP PLUG S2
12	V836529872	1	PLUG
13	V640016018	1	CUP PLUG
14	V640325110	2	SCREW PLUG
15	V615571014	2	SEALING WASHER S2
16	V614601524	1	O-RING
17	V640325018	1	PLUG
18	V615881822	2	SEALING WASHER S2
19	V836766991	1	ENGINE MOUNT RIGHT
20	V836766992	1	ENGINE MOUNT LEFT
21	V836666910	1	OIL DIPSTICK GUIDE PIPE
22	V836647622	1	ENGINE BLOCK HEATER
23	V836664377	1	DRAIN VALVE
24	V836119837	1	HOSE COUPLER
25	V615881824	1	SEALING WASHER S2
26	V615881216	1	SEALING WASHER
27	V640045112	1	PLUG
28	V528801362	1	HEX CAP SCREW M8 X 16
29	V836866957	1	COVER
30	V836866958	1	GASKET S2
31	V836855093	4	OIL NOZZLE
32	V836338601	4	PRESSURE VALVE
33	V500050840	1	FLAT WASHER
34	V581705850	2	HEX SOCKET SCREW M14 X 40
35	V581705890	2	HEX SOCKET SCREW M14 X 60
36	V581804600	4	HEX SOCKET SCREW M8 X 20

200

SEE PAGE 01-0024

XM150 TRACTOR (XM SERIES)
SPIMG-015-21-04

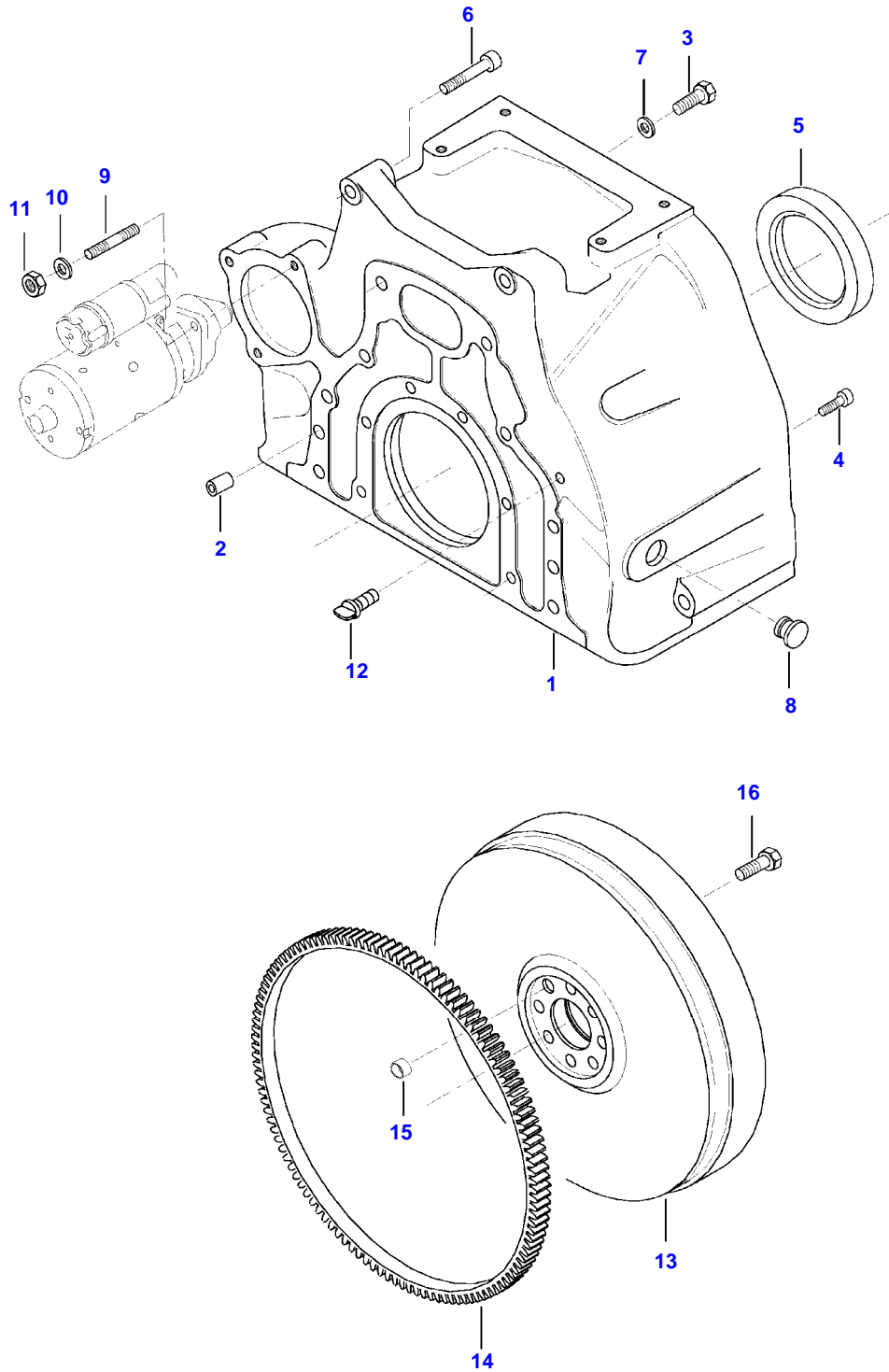

Item	Part Number	Qty	Description Comments
1	V836666482	1	FLYWHEEL HOUSING
2	V598359850	2	PIN
3	V529702220	8	HEX CAP SCREW M12 X 35
4	V581705030	6	HEX SOCKET SCREW M10 X 30
5	V614500002	1	CRANKSHAFT SEAL S2
6	V581705490	2	HEX SOCKET SCREW M12 X 60
7	V500951200	8	SPRING WASHER
8	V836007572	1	RUBBER PLUG
9	V546801800	3	STUD BOLT M10 X 25
10	V500951000	3	SPRING WASHER
11	V504601000	3	NUT M10
12	V836859311	1	PLUG
13	V836659990	1	FLYWHEEL
14	V835328783	1	STARTER RING
15	V836659527	1	GUIDE SLEEVE
16	V529702250	8	HEX CAP SCREW 150 NM

XM150 TRACTOR (XM SERIES)
SPIMG-011-21-06

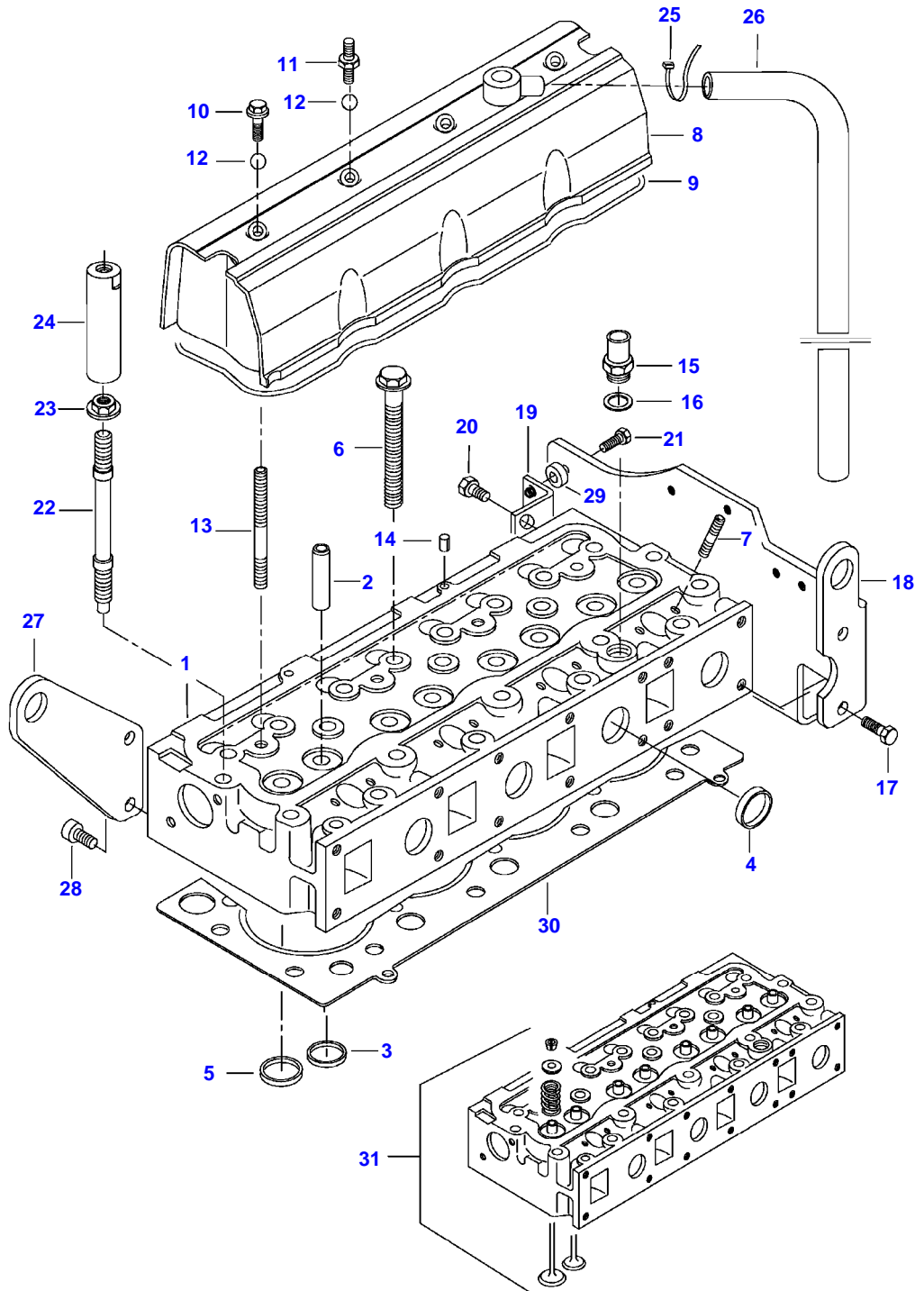

Item	Part Number	Qty	Description Comments
1	V836755385	1	CYLINDER HEAD
2	V836647601	8	GUIDE
3	V836647600	4	VALVE SEAT
4	V836647942	8	EXHAUST CUP PLUG
5	V836647936	4	VALVE SEAT
6	V836859104	21	HEXAGON FLANGE BOLT
7	V546901435	8	STUD BOLT M8 X 40
8	V836767207	1	VALVE COVER
9	V614738740	1	COVER GASKET S1
10	V540801780	3	HEXAGON FLANGE BOLT
11	V836667033	1	STUD BOLT
12	V614901030	4	O-RING S1
13	V546801900	4	STUD BOLT M10 X 75
14	V595959140	2	PIN
15	V836119837	1	HOSE COUPLER
16	V615881822	1	SEALING WASHER S1
17	V528801800	2	HEX CAP SCREW M10 X 25
18	V836767031	1	SUPPORT
19	V836659278	1	BRACKET
20	V528801760	2	HEX CAP SCREW M10 X 16
21	V528801360	2	HEX CAP SCREW M8 X 16
22	V836859109	1	STUD BOLT
23	V836859110	1	NUT
24	V836667062	1	LIFTING EYE EXTENSION
25	V835329746	1	CABLE TIE
26	V836755007	1	RUBBER HOSE
27	V836667203	1	LIFT EYE
28	V581705000	2	HEX SOCKET SCREW M10 X 20
29	V836119067	2	SPACER PIECE
30	V837070291	1	CYLINDER HEAD GASKET S1
31	V836740869	1	CYLINDER HEAD

XM150 TRACTOR (XM SERIES)
SPIMG-015-21-08

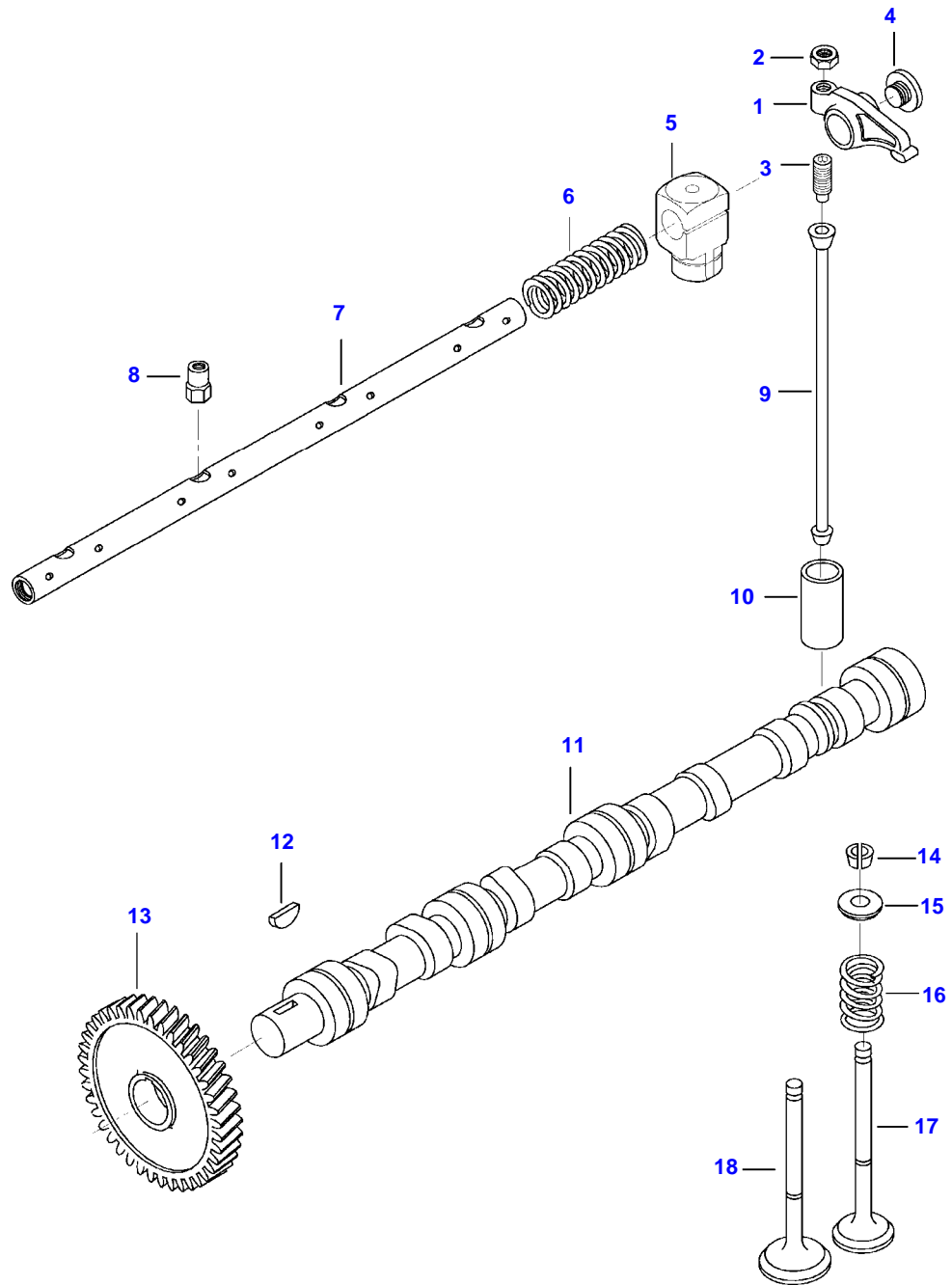

Item	Part Number	Qty	Description Comments
	V836767044	1	ROCKER SHAFT ASM ASSEMBLY
1	V836666608	8	ROCKER ARM . -S12222 (M)
	V836667042	8	ROCKER ARM . S12223- (M)
2	V512861000	8	NUT
3	V836655866	8	ADJUSTING SCREW .. -S12222 (M)
	V837069023	8	VALVE ROCKER ADJUSTMENT SCREW .. S12223- (M)
4	V836655899	2	PLUG . -S12222 (M)
	V837069020	2	PLUG . S12223- (M)
5	V836666609	4	BRACKET
6	V836655884	3	SPRING
7	V836755871	1	SHAFT . SLEEVE NUT
8	V836655406	4	SLEEVE NUT
9	V836655867	8	PUSHROD
10	V836014264	8	TAPPET
11	V836746375	1	CAMSHAFT
12	V603305760	1	WOODRUFF KEY
13	V836646389	1	GEAR,CAMSHAFT
14	V836646382	16	COTTER
15	V836646381	8	WASHER
16	V836646380	8	SPRING
17	V836646357	4	EXHAUST VALVE
18	V836646356	4	INTAKE VALVE

Item	Part Number	Qty	Description Comments	Technical Specification
1	V836766489	1	CRANKSHAFT	
2	V836124524	1	GEAR	
3	V836666103	4	PISTON	
4	NS	4	NON-SERVICEABLE PART	
5	NS	8	PISTON PIN NON-SERVICEABLE PART	
6	V836640078	4	CIRCLIP PISTON RING KIT	
7	V836740859	4	CONNECTING ROD KIT NON-SERVICEABLE PART	
	NS	4	CONNECTING ROD 11935-1954 G F NON-SERVICEABLE PART	
	NS	4	CONNECTING ROD 11955-1974 G V NON-SERVICEABLE PART	
	NS	4	CONNECTING ROD 11975-1994 G X NON-SERVICEABLE PART	
	NS	4	CONNECTING ROD 11995-2014 G Y NON-SERVICEABLE PART	
	NS	4	CONNECTING ROD 12015-2034 G W NON-SERVICEABLE PART	
	NS	4	CONNECTING ROD 12035-2054 G Z NON-SERVICEABLE PART	
	NS	4	CONNECTING ROD 12055-2074 G G NON-SERVICEABLE PART	
8	V836864141	8	CONNECTING ROD BOLT	
9	V836110646	4	BEARING BUSH	STD
10	V836110552	4	BEARING SHELL	
11	V836655514	5	MAIN BEARING	
12	V836119459	2	THRUST WASHER	
13	V836119550	1	GEAR,CRANKSHAFT	
14	V836122840	1	GEAR,CRANKSHAFT	
15	V836129781	1	RING	
16	V836136271	1	SHIELD	
17	V836846463	1	CRANKSHAFT HUB	
18	V595953360	1	PIN	
19	V836766988	1	CRANKSHAFT PULLEY	
20	V836647310	1	CRANKSHAFT NUT	
21	V581804600	6	HEX SOCKET SCREW M8 X 20	
22	V603345110	1	KEY	

XM150 TRACTOR (XM SERIES)
SPIMG-015-21-12

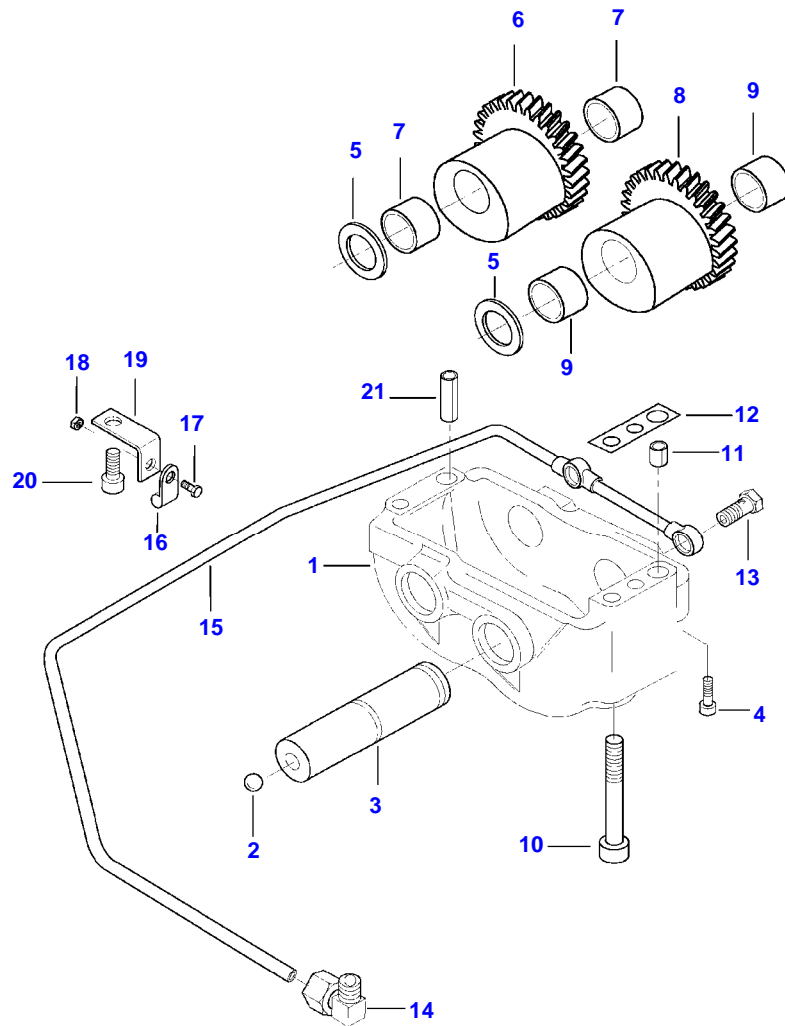

Item	Part Number	Qty	Description Comments
1	V836766994 NS	1 1	COUNTERWEIGHT NON-SERVICEABLE PART
2	V616810103	2	FRAME BALL
3	V836146879	2	SHAFT
4	V581804202	2	HEX SOCKET SCREW
5	V836146880	4	M6 X 20 THRUST WASHER
6	V836766121	1	COUNTERWEIGHT
7	V836146876	2	BEARING BUSH
8	V836766122	1	COUNTERWEIGHT
9	V836146876	2	BEARING BUSH
10	V581805170	4	HEX SOCKET SCREW M10 X 100
11	V598359850	1	PIN
12	V836119920	X	SHIM
13	V640435008	2	BANJO BOLT
14	V641166008	1	ELBOW FITTING
15	V836766995	1	OIL PIPE
16	V602071608	1	RETAINER CLAMP
17	V528801062	1	HEX CAP SCREW M6 X 16
18	V504600602	1	NUT M6
19	V836346571	1	BRACKET
20	V581804980	1	HEX SOCKET SCREW M10 X 16
21	V598359890	1	PIN

XM150 TRACTOR (XM SERIES)
SPIMG-015-21-14

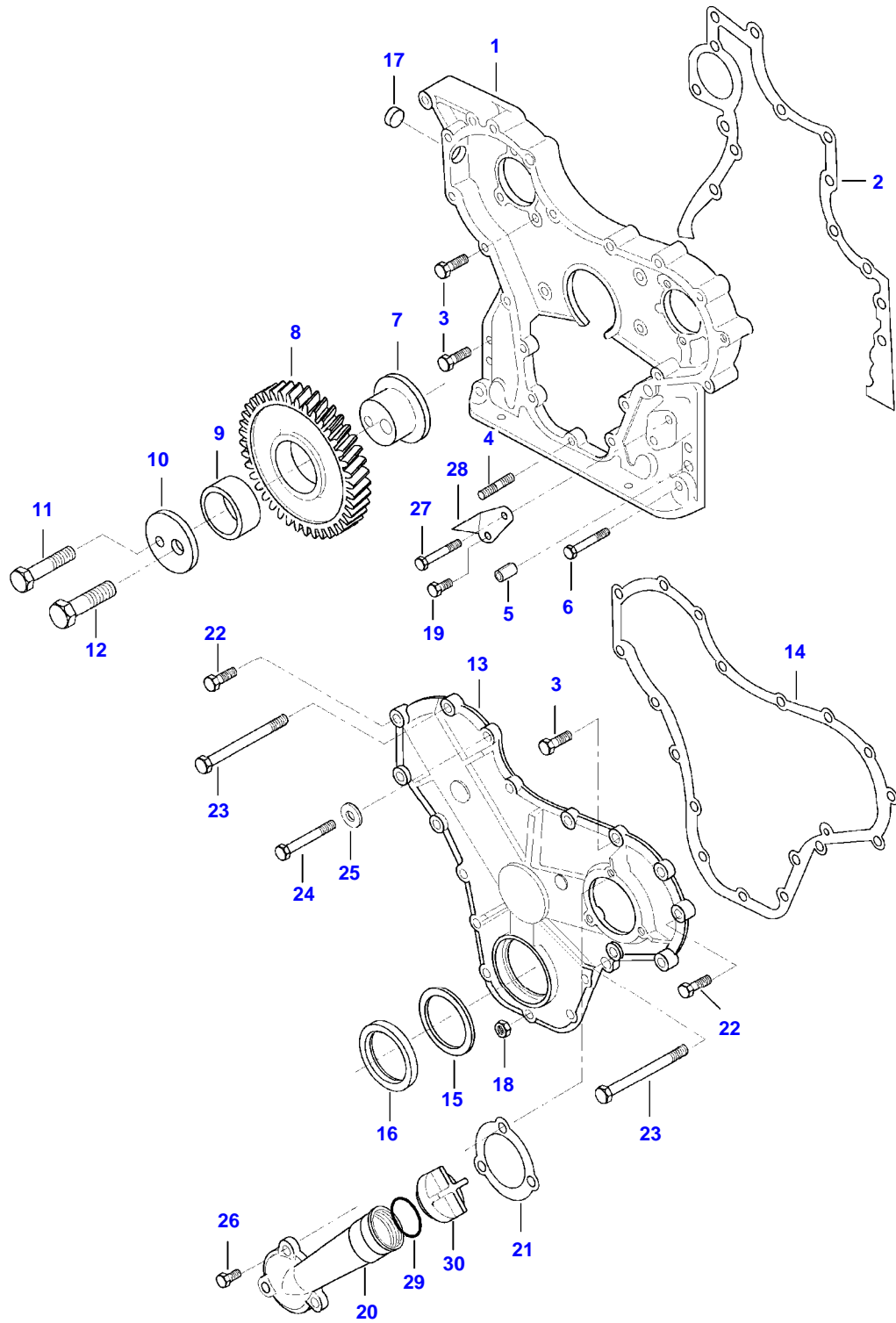

Item	Part Number	Qty	Description Comments	Technical Specification
1	V836666400	1	TIMING GEAR CASE -S9538 (M)	
	V836667947	1	TIMING GEAR CASE S9539- (M)	
2	V836647419	1	GASKET S2 -S9538 (M)	
	VUK0182	1	GASKET SEALPASTE S9539- (M)	250ML
3	V528801400	11	HEX CAP SCREW M8X25	
4	V546801380	5	STUD BOLT M8X20	
5	V598359850	4	PIN	
6	V529801440	2	HEX CAP SCREW M8X45	
7	V836129709	1	SHAFT	
8	V836129863	1	IDLER GEAR	
9	V836129844	1	BEARING BUSH	
10	V836129845	1	FLANGE	
11	V528801860	1	HEX CAP SCREW M10X55	
12	V529902680	1	HEX CAP SCREW M14X65	
13	V836647572	1	GEAR HOUSING FRONT COVER	
14	V836129942	1	GASKET S2 -S9538 (M)	
	VUK0182	1	GASKET SEALPASTE S9539- (M)	250ML
15	V836129782	1	COVER	
16	V614105880	1	OIL SEAL S2	
17	V640016016	1	CUP PLUG	
18	V504800800	5	NUT M8	
19	V528801362	1	HEX CAP SCREW M8X16	
20	V835338325	1	ENGINE OIL FILL PIPE	
21	V836129946	1	GASKET S2	
22	V528801420	3	HEX CAP SCREW M8X35	
23	V529801500	2	HEX CAP SCREW M8X75	
24	V529801470	3	HEX CAP SCREW M8X60	
25	V836120989	1	WASHER	
26	V528801380	3	HEX CAP SCREW M8X20	
27	V529801450	1	HEX CAP SCREW M8X50	
28	V836747675	1	TIMING MARK INDICATOR	
29	V614603540	1	O-RING	
30	V836017927	1	CAP	

XM150 TRACTOR (XM SERIES)
SPIMG-015-21-16

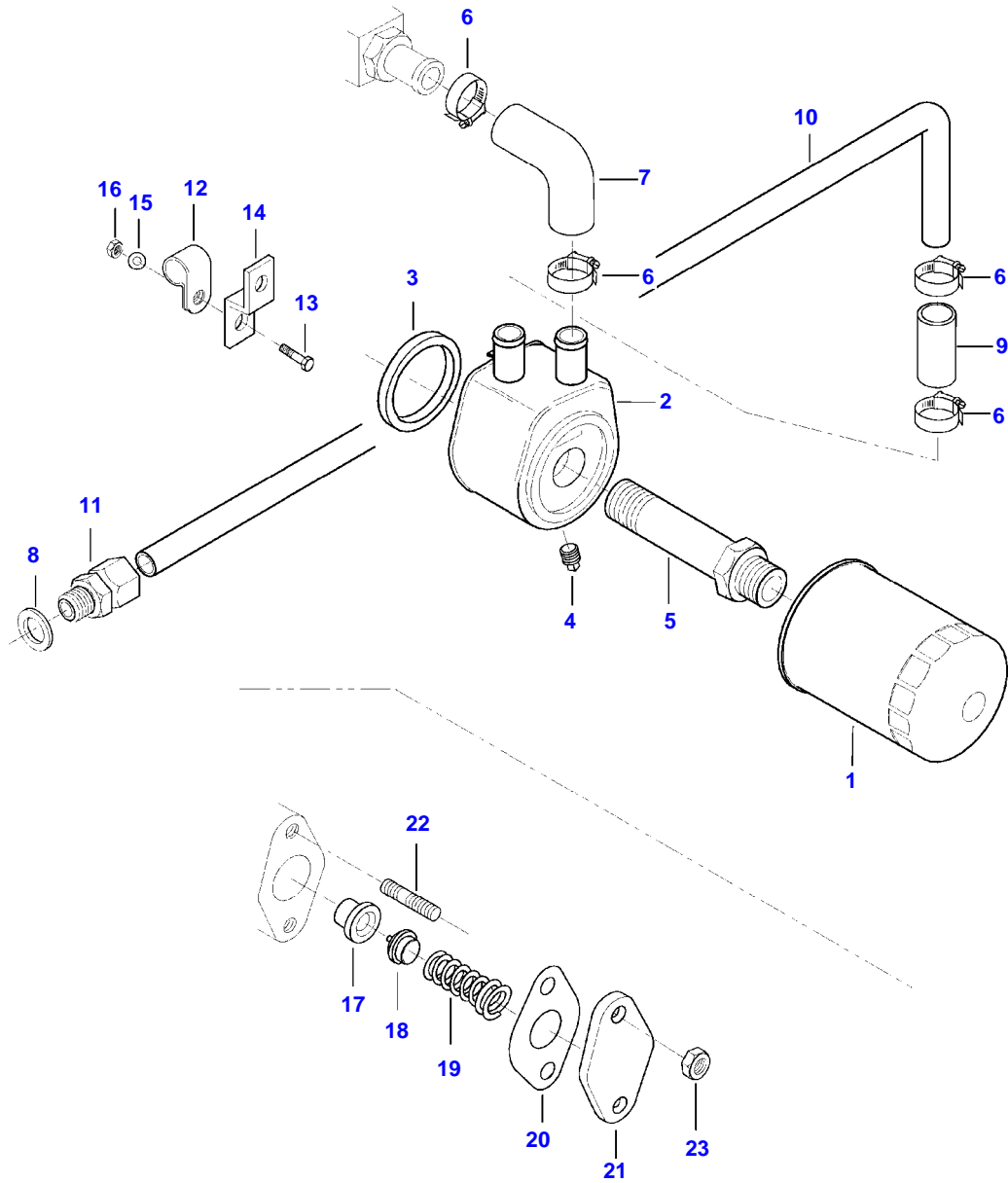

Item	Part Number	Qty	Description Comments
1	V836662580	1	ENGINE OIL FILTER
2	V836859699	1	OIL COOLER
3	V836862235	1	SEAL
4	V836131366	1	PLUG
5	V836859700	1	UNION
6	V602079516	4	HOSE CLIP
7	V836859899	1	RUBBER ELBOW
8	V615881822	1	SEALING WASHER S2
9	V836129978	1	RUBBER HOSE
10	V836747848	1	PIPE
11	V641086015	1	STRAIGHT FITTING
12	V602074615	1	RETAINER CLAMP
13	V528801102	1	HEX CAP SCREW M6 X 25
14	V836747849	1	SUPPORT
15	V500050642	2	WASHER
16	V504600602	1	NUT M6
17	V836662130	1	OIL PRESSURE CONTROL VALVE
17	V836659521	1	VALVE SEAT
18	V836659522	1	VALVE CONE
19	V836864056	1	END
20	V836322190	1	GASKET S2
21	V836659524	1	COVER
22	V546801400	2	STUD BOLT M8 X 25
23	V504800800	2	NUT M8

Item	Part Number	Qty	Description Comments
1	V836767500	1	OIL SUMP
2	V836129728	1	OIL SUMP GASKET S2
3	V581704850	2	HEX SOCKET SCREW M8 X 180
4	V581705510	4	HEX SOCKET SCREW M12 X 70
5	V615881827	1	SEALING WASHER S2
6	V836655493	1	PLUG
7	V836014330	1	DIPSTICK
8	V581804600	6	HEX SOCKET SCREW M8 X 20
9	V836766998	1	OIL PUMP SUCTION PIPE
10	V836766996	1	OIL PIPE
11	V614602030	1	O-RING S2
12	V836129727	2	GASKET S2
13	V581705490	14	HEX SOCKET SCREW M12 X 60
14	V504801200	14	NUT M12
15	V836652603	1	LUBRICATING OIL PUMP
15	V504861000	1	NUT M10
16	V836122910	1	WASHER
17	V836338667	1	GEAR
18	V836120195	1	HOUSING
19	V528801380	4	HEX CAP SCREW M8 X 20
20	V836652600	1	OIL PUMP SHAFT
21	V836120191	1	OIL PUMP SHAFT
22	V836120193	1	GEAR
23	V836119796	1	GASKET S2
24	V836119794	1	COVER
25	V836008449	2	GASKET S2
26	V581805050	2	HEX SOCKET SCREW M10 X 40
27	V836007871	X	SHIM

XM150 TRACTOR (XM SERIES)
SPIMG-015-21-20

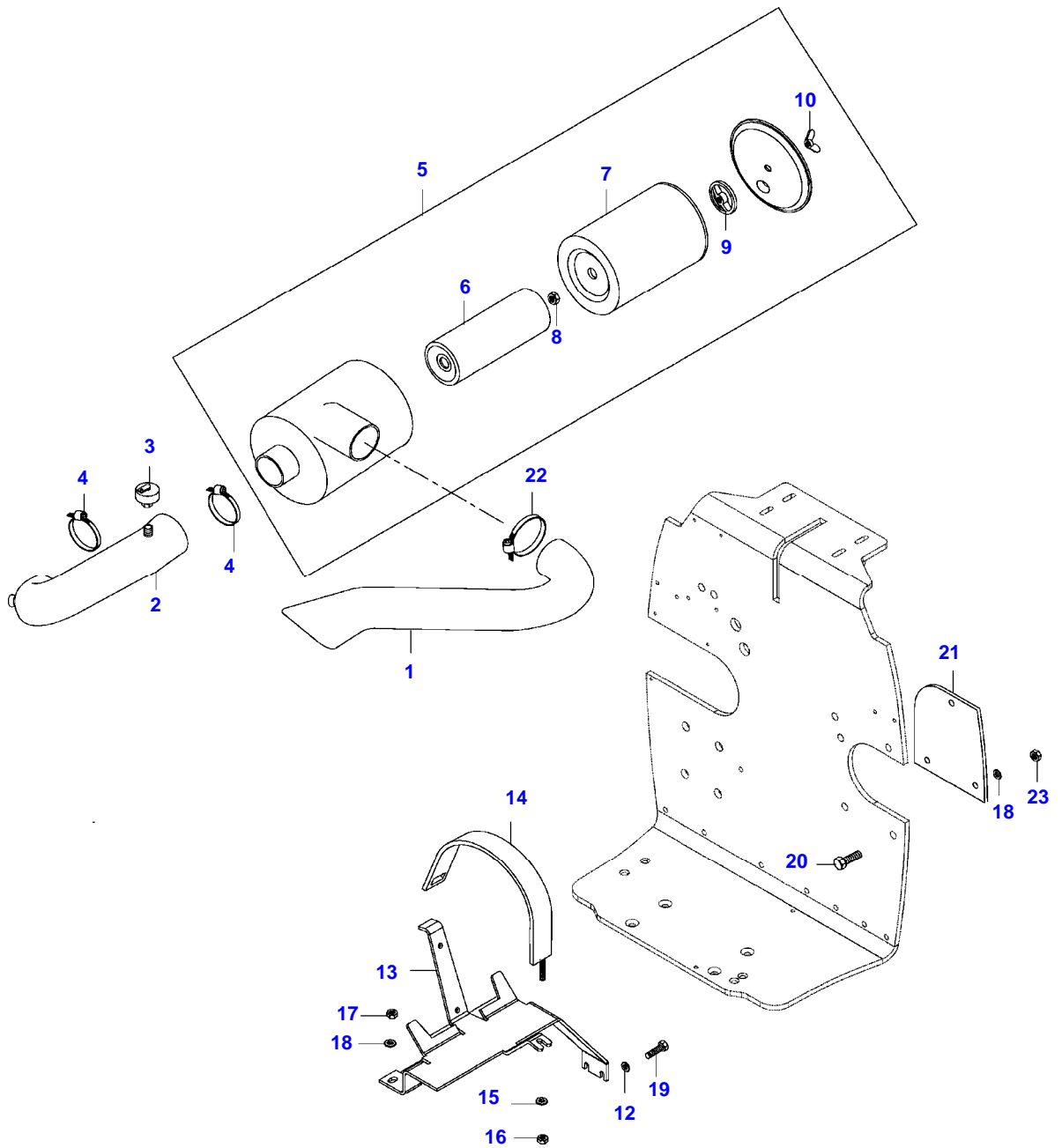

Item	Part Number	Qty	Description Comments	Technical Specification
1	V35284900	1	SUCTION PIPE -N26111	
	V35284910	1	SUCTION PIPE N26112-	
2	V35285110	1	SUCTION PIPE	
3	V34654000	1	SENSOR	65 BAR
4	VGP3933	2	HOSE CLIP	D=95 SMS2298
5	V35188910	1	AIR FILTER ASSEMBLY	D=225
6	V836462569	1	SECONDARY AIR FILTER ELEMENT . D=85 L=370	
7	V836462568	1	PRIMARY AIR FILTER ELEMENT . D=165 L=380	
8	VJB8905	1	LOCKNUT	M10 SFS_EN_ISO_10511
9	V35315600	1	NUT	
10	VJC1610	1	BLADE NUT	M10 DIN315 G5 ZNE
12	VJD0408	2	WASHER	M8
13	V35289000	1	CARRIER	
14	V35296300	1	HOLDER	
15	V686930	1	WASHER	
16	VJB8904	1	NUT	M8
17	VJB1110	1	NUT	M10
18	V33225800	3	WASHER	8.5 X 2 SFS_3738
19	VHA6323	2	SCREW	M8 X 20 CL8.8
20	VHA6508	3	SCREW	M8 X 25 SFS_EN_ISO_4017 8.8
21	V36187800	1	STAY PLATE	
22	VGP3933	1	HOSE CLIP -N26111	D=95 SMS2298
	VGP3936	1	HOSE CLIP N26112-	D=138 SMS2298
23	VJB1103	3	NUT	M3 SFS-EN_ISO_4032

XM150 TRACTOR (XM SERIES)
SPIMG-011-21-22

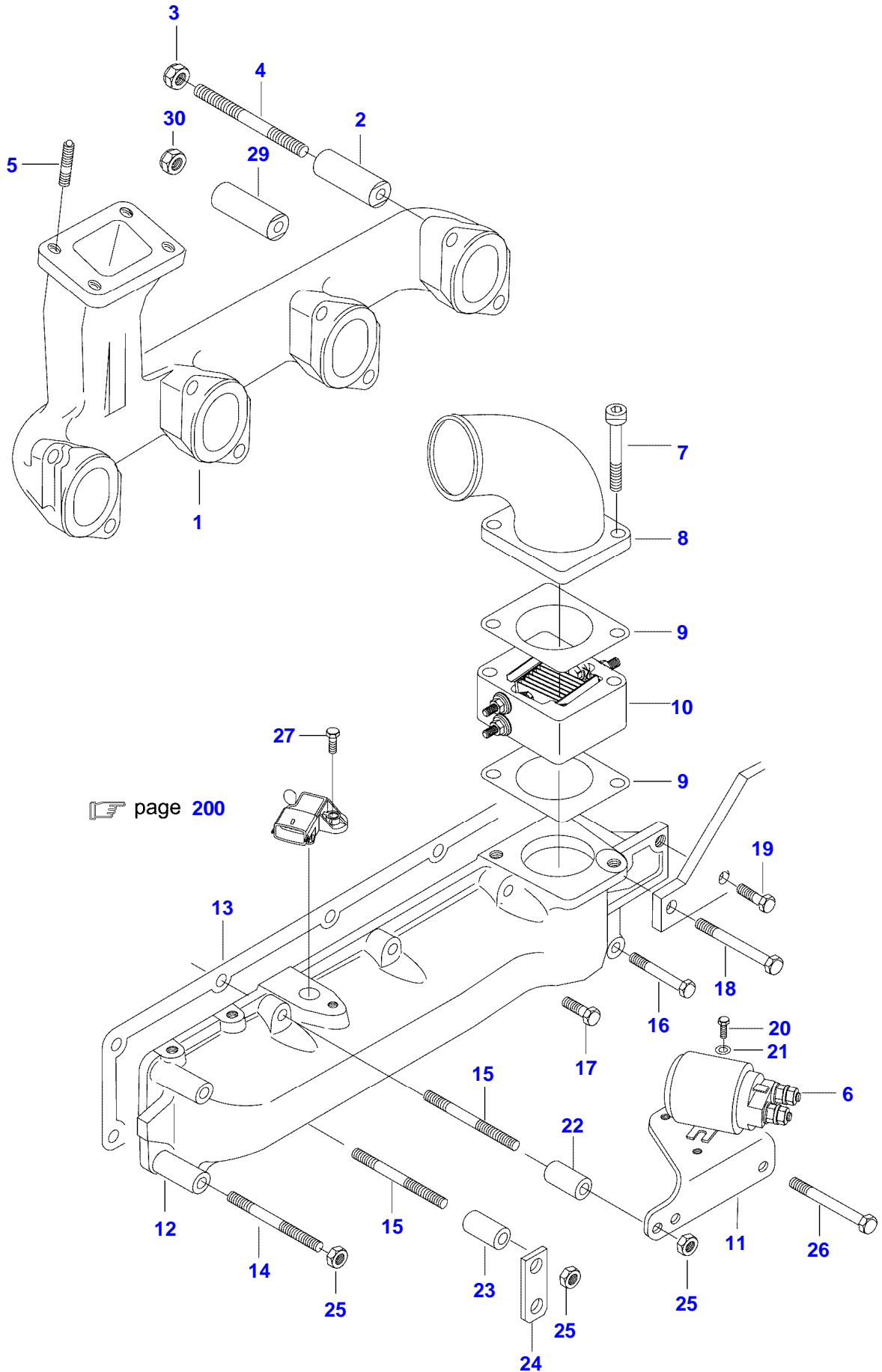



Suggest:

For more complete manuals. Please go to the home page.

<https://www.ebooklibonline.com>

If the above button click is invalid. Please download this document first, and then click the above link to download the complete manual.

Thank you so much for reading

Item	Part Number	Qty	Description Comments
1	V836766932	1	EXHAUST MANIFOLD
2	V836664013	4	SPACER PIECE
3	V513601002	4	NUT M10
4	V836859188	8	STUD BOLT M10 X 100
5	V546801380	4	STUD BOLT M8 X 20
6	V836666759	1	SOLENOID
7	V581705080	2	HEX SOCKET SCREW M10 X 55
8	V836767027	1	AIR PIPE - 07.2004
	V836767248	1	AIR PIPE 90° 08.2004-
9	V836666074	2	GASKET S1
10	V836666073	1	INTAKE AIR PREHEATER 12V/1.2KW
11	V836766752	1	BRACKET
12	V836766828	1	INTAKE MANIFOLD
13	V836747595	1	INTAKE MANIFOLD GASKET S1
14	V546801510	2	STUD BOLT M8 X 80
15	V546801540	2	STUD BOLT M8 X 95
16	V529801470	1	HEX CAP SCREW M8 X 60
17	V528801410	3	HEX CAP SCREW M8 X 30
18	V529801490	1	HEX CAP SCREW M8 X 70
19	V528801380	1	HEX CAP SCREW M8 X 20
20	V528800760	2	HEX CAP SCREW M5 X 16
21	V500150532	2	WASHER
22	V836866960	2	SPACER PIECE
23	V836659630	1	SPACER PIECE
24	V836446243	2	SUPPORT
25	V504800800	4	NUT M8
26	V529801530	1	HEX CAP SCREW M8 X 90
27	V528801080	1	SCREW M6 X 20
28	V500050642	1	WASHER
29	V836652803	4	SPACER PIECE
30	V504601000	4	NUT M10

200

SEE PAGE 01-0024

XM150 TRACTOR (XM SERIES)
SPIMG-015-21-24

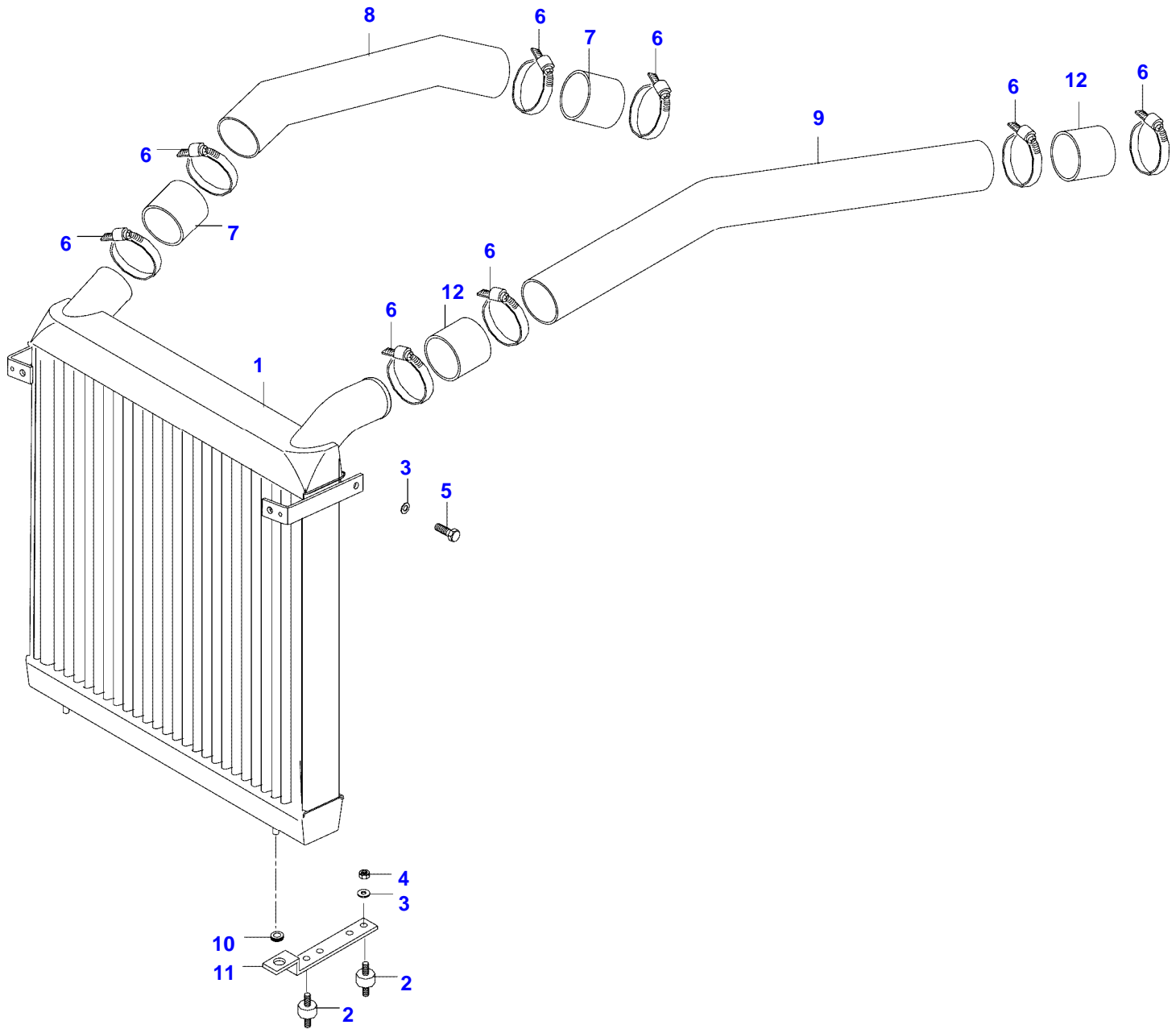

<https://www.ebooklibonline.com>

Hello dear friend!

Thank you very much for reading.

Enter the link into your browser.

The full manual is available for immediate download.

<https://www.ebooklibonline.com>