

SECTION 660-02

Front Shaft 4x4

ON-VEHICLE APPLICATION Heavy Duty

Table of Contents

Subject
SPECIFICATIONS
DESCRIPTION AND OPERATION
REMOVAL AND INSTALLATION
Front Shaft (Carraro)
Front differential assembly
Front Traction Drive Lever
Front Traction Cardan Shaft
Bushings and Retainers of Housings and Articulations (Front Shaft)
COMPLETE DISASSEMBLY AND ASSEMBLY
Front differential assembly
PARTIAL DISASSEMBLY AND ASSEMBLY
Front differential assembly
DISASSEMBLY AND ASSEMBLY
Planetary Gears and Front Shaft Rollers (Carraro) (Removed Shaft)
Crown and Pinion Set of the Front Differential
Conical ball bearings of the front differential
Pinion conical ball bearings of the front differential
Front differential housing
Front Differential Box
Front Differential Box Cover

Assembly of the planetary gears and satellites of the front differential
Thrust rings of the planetary gears of the front differential
Block Disks Set of the Front Differential
Final Reducers
Shaft Support Bearings
Wheel hubs and Joints
Cylinder, Bars and Steering Pivots

SPECIFICATIONS

Front Shaft 4x4

Technical Data of the Front Shaft 4x4 Carraro

Description	Specification
Kind of Shaft	Carraro 20.43
Kind of automatic block	standard
Differential ratio	2.538
Reducer hub ratio	6.923
Total ratio	17.570
Ratio between front and rear shaft	1.315
Adjustable direction angle	+/-7°
Oscillation angle	6°
Catheter	7°
Camber	1.5°
Convergence	0 – 5 mm
Gauge	1900 mm

Tightening torque

Wheel Hubs

Description	N.m	(Kgf.m)
Planetary support cover	25	(2.5)
Planetary fixing screws	80	(8)
Gears support fixing screws	230	(23)
Pivots fixing screws	190	(19)
Wheel Studs	550	(55)
Front wheels studs with the wheel hub	70	(7)
Steering terminals fixing nuts	220	(22)

<https://www.ebooklibonline.com>

Hello dear friend!

Thank you very much for reading.

Enter the link into your browser.

The full manual is available for immediate download.

<https://www.ebooklibonline.com>

Pinion shaft / Differential

Description	N.m	(Kgf.m)
Pinion shaft fixing nut, according to the established pre-load.	REFER to Section 110-03.	
Outer flange fixing screws of the cardan shaft	70	(7)
Outer flange fixing screws of the pinion shaft	60	(6)
Housing arms fixing screws of the front shaft	170	(17)
Bi-party bearings fixing screws of the differential	265	(27)
Crown fixing screws	70	(7)
Differential set fixing screws to the front shaft housing	REFER to Section 110-03.	
Fixing screws of the adjustment locking nuts of the crown	13	(1.3)
Drain plug / filling	60	(6)

Miscellaneous

Description	N.m	(Kgf.m)
Center bearings fixing screws	380	(38)
Steering terminals locking nuts	250	(25)
Steering terminals, together with the steering hydraulic cylinder rod	300	(30)
Stop screws locking nuts	150	(15)
Fixing screws of the steering cylinder	120	(12)
Studs of the fixing arms of the bearing center	200	(20)

Adjustments

Description	N.m	Kg
Preload of the conical ball bearings of the differential (dynamometer balance)	REFER to Section 110-03.	6...9
Preload of the conical ball bearings of the pinion shaft (dynamometer balance)	REFER to Section 110-03.	3...5
Preload of the conical ball bearings of the pinion shaft + differential (dynamometer balance)	REFER to Section 110-03.	9...14

Clearances

Description	mm
Clearance between the ring gear and the pinion	0.17...0.23
Clearance between the satellite gear set and shaft	0.10...1.10
Clearance between the satellite set	0.13...0.18

Dimension

Description	mm
Thickness of the separators (pinion)	2.50...3.40
Thickness of thrust washers of the satellites with gear of 0.1 mm	1.45...1.55
Thickness of the automatic locking of the steel disks	1.43...1.47
Thickness of the friction discs	2.24...2.36

Lubrication

Description	Specification
Lubrication mode	Spill and immersion
Oil for manual transmission of high pressure.	SAE 80 w 90 API GL 5
Grease for various applications (Multi use)	EP-2

Capacity

Description	Specification
Differential	6
Reducer	1,5 (each)

DESCRIPTION AND OPERATION

Front Shaft 4 x4

The front shaft differential Carraro has as standard an automatic lock.

The friction discs are mounted between the planetary gears and the differential box.

The semi-axles are supported by bushings within the shaft housing and by ball bearings in the articulation hub.

In each hub of the planetary reducer, the pins of the planetary gear (3 pieces) are housed in cylindrical roller ball bearings and supported by the planetary reducer housing. The flange which supports the ring gear is fixed through screws to the articulation housing.

The articulation housing is mounted in the front shaft housing through the articulation pivots which are accommodated in conic roller ball bearings in the articulation hub. The preload of the conic roller ball bearings of the articulation pivots are adjusted with shims on the upper pivot.

The pinion position (depth / height) is determined by adjusting shim behind the front conic ball bearing bearing of the pinion.

The pre-load of the conic ball bearings of the pinion is governed by the elastic spacer ring in the middle of the pinion shaft.

The preload of the differential ball bearings and the clearance between the teeth of the crown and pinion set are adjusted by toothed adjustment nuts of the crown.

The preload of the ball bearings of the articulation pivots and the wheel hubs is adjusted with shims.

In the following pages there are many panoramic pictures of the Carraro front shaft 4x4 construction.

Maintenance intervals and the oil quality are the same as that used in SIGE SHAFT.

Regarding the grease lubrication points, these should be greased every 50 hours.

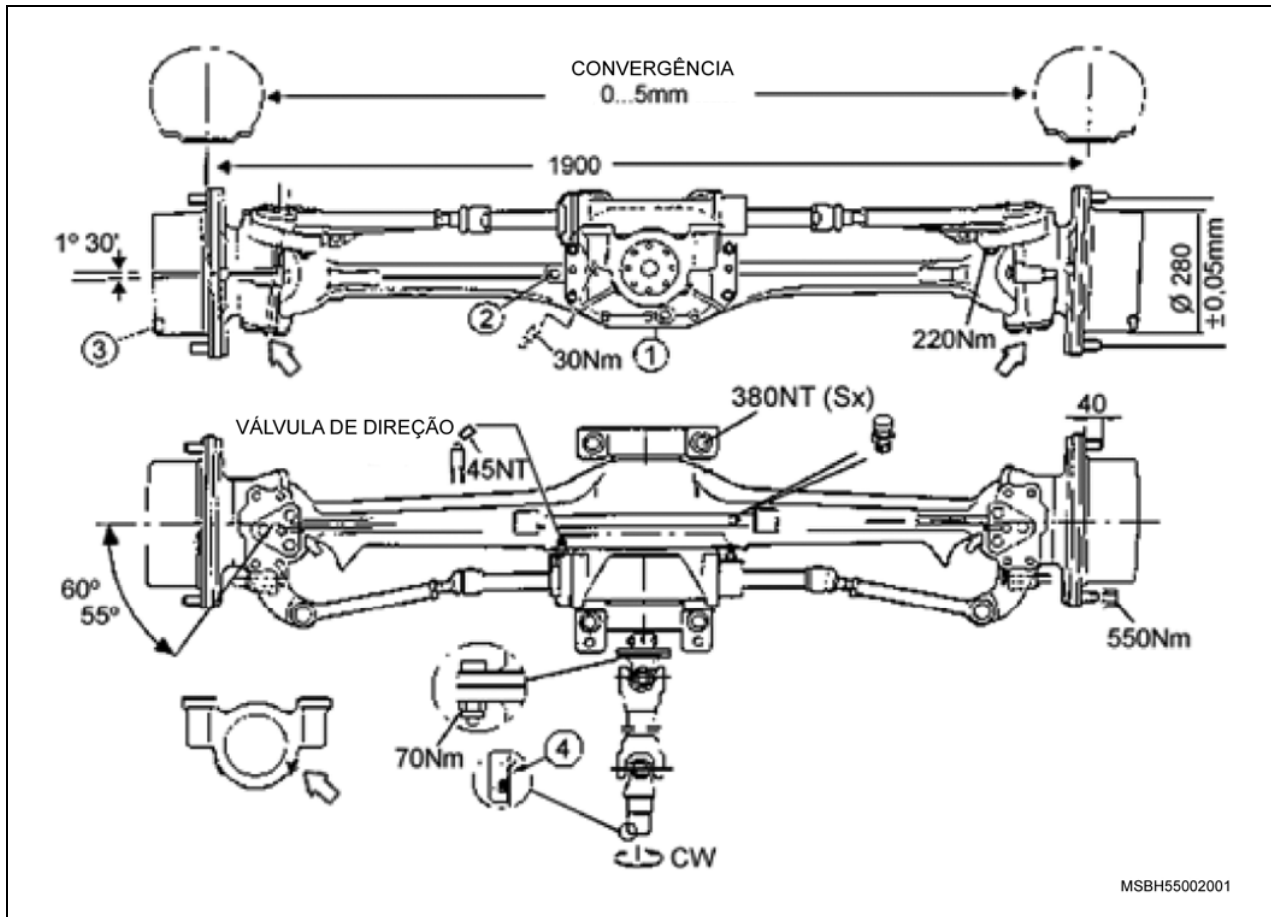

Item	Description
1	Drain plug of the shaft housing
2	Filling plug
3	Drain plug and filling hub
4	EP grease for the grooves

Carraro shaft differential

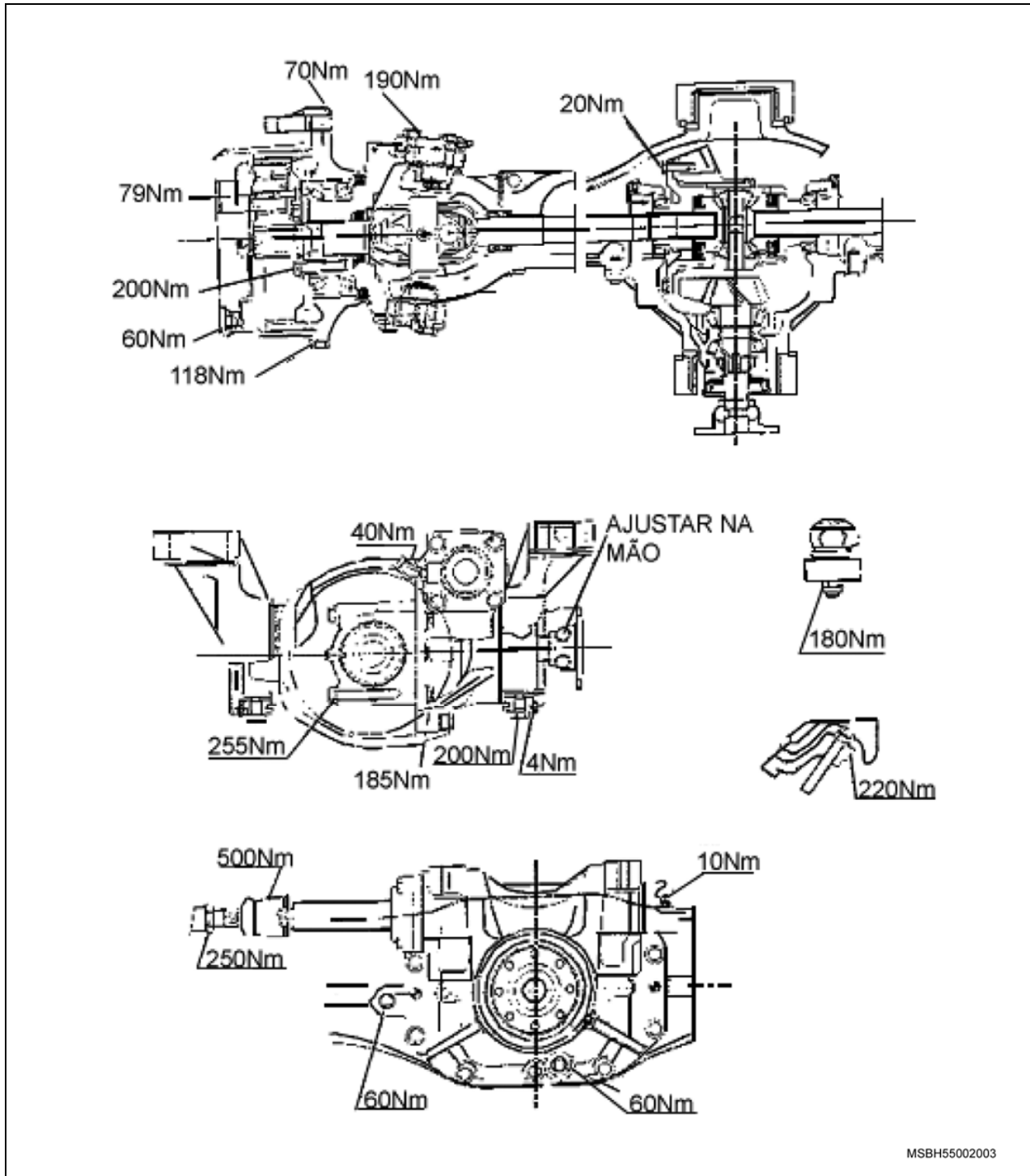

Item	Description
1	Elastic separator

Steering cylinder

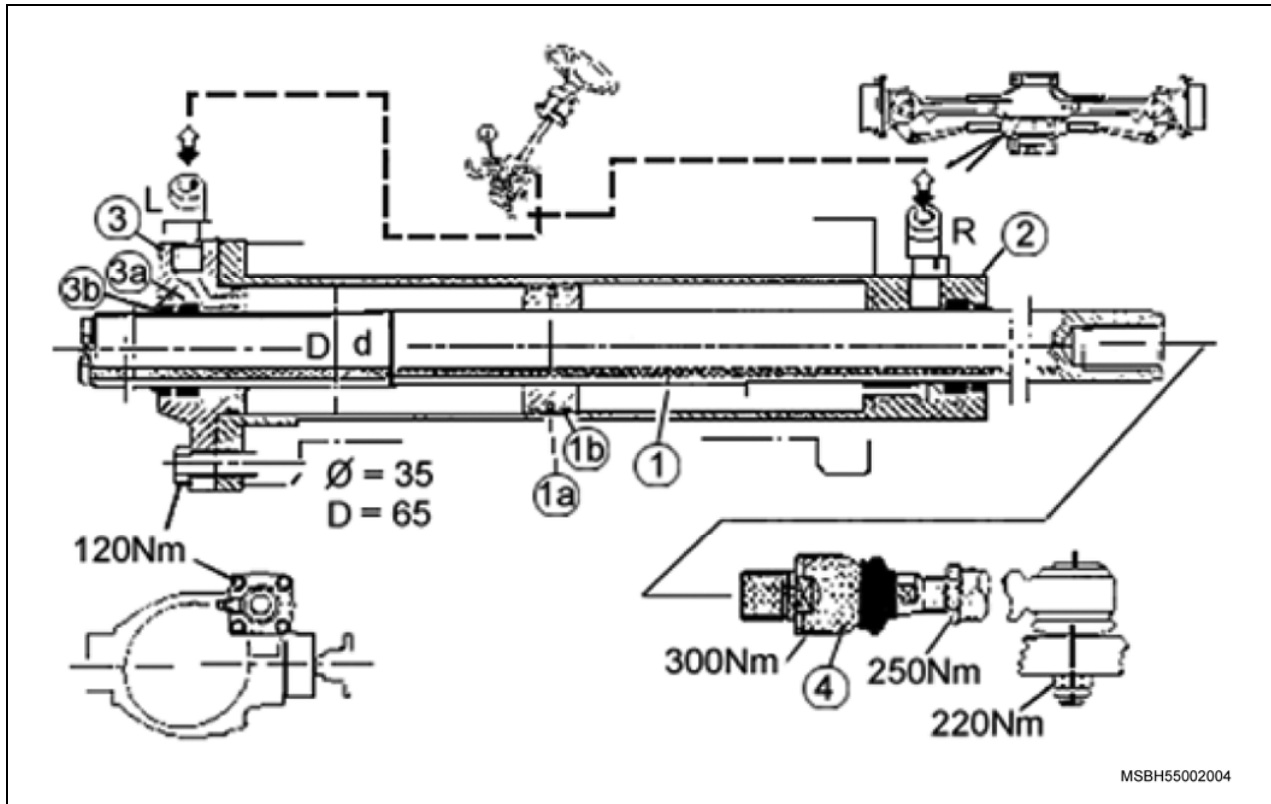

MSBH55002004

Item	Description
1	Steering cylinder rod
1a	Piston retaining
1b	Wear ring
2	Cylinder sleeve
3	Cylinder cover
3a	Scraper retaining
3b	Oil retaining

REMOVAL AND INSTALLATION

Front Shaft (Carraro)

Removal

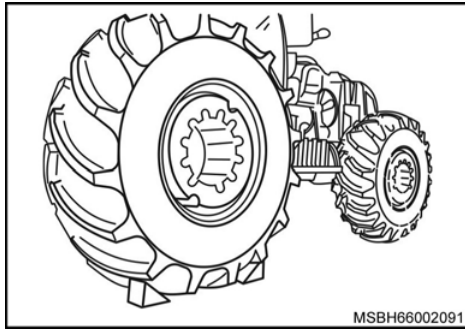

1. BLOCK the rear wheels with wooden wedges and PULL the parking brake.

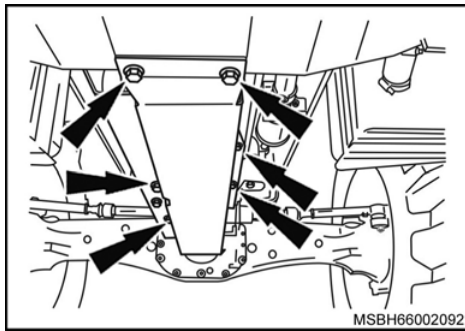

2. LOOSEN and REMOVE the fixing screws (arrows) of the cardan shaft shield and REMOVE the protector.

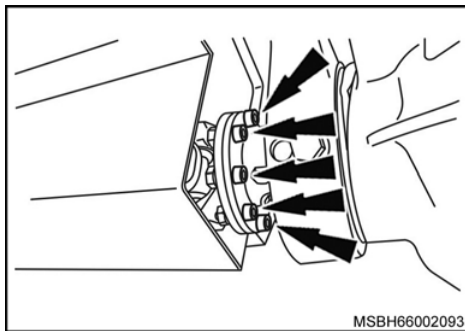

3. LOOSEN and REMOVE the fixing screws (arrows) of the cardan shaft in the front axle flange.

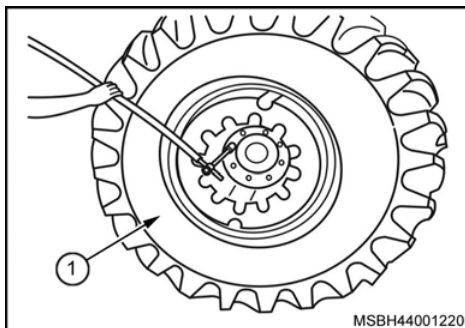

4. LOOSEN the front wheel fixing nuts (1) but do not remove them.

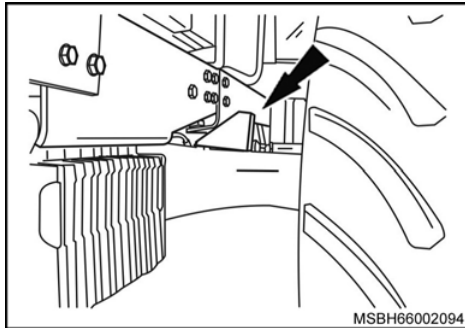

5. BLOCK the front shaft with wooden wedges in both sides, to secure its balance when removing the front wheels.

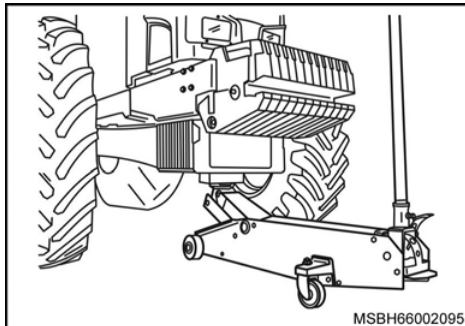

6. PLACE the hydraulic jack under the transversal weights. RAISE the tractor until the front wheels are distant from the floor.

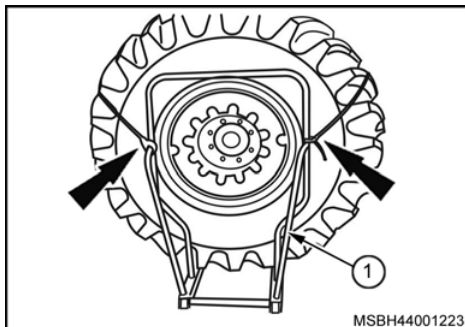

7. PLACE a special stand at the center of one of the front wheels, LOWER the jack until the wheel rests on the stand (1). PASS an account around the wheel tying it to the stand (arrows). REMOVE the wheel fastening nuts PULL the stand.

8. To remove the front wheel on the other side, DO the same procedures as the previous operation.

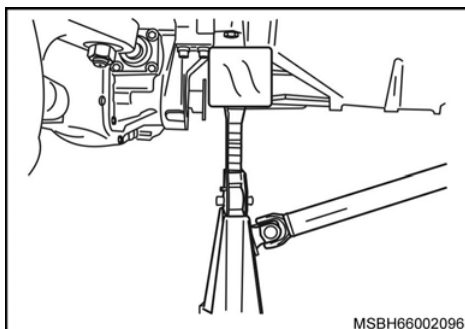

9. PLACE a bracket in the flat part of the crankcase housing, and using the hydraulic jack, LOWER the front of the tractor over the bracket.

10. After supporting the front of the tractor over the bracket, REMOVE the hydraulic jack.

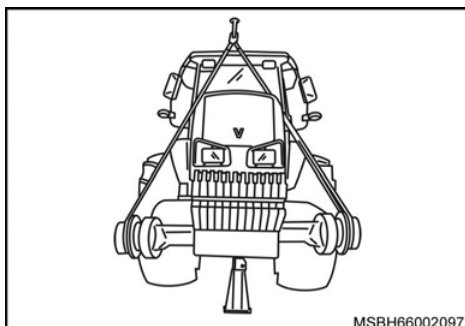

11. USE a specific strap attached to the hook of a hoist or giraffe fitting its tips at the ends of the shaft around the hubs, among the prisoners. The strap should be stretched before loosening the fixing screws of the front shaft bearings.

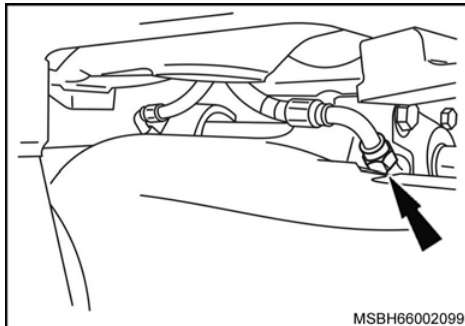
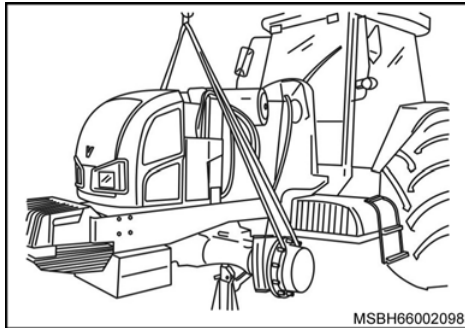

12. RELEASE the fixing nuts (arrows) of the steering hoses, mounted on the front shaft connections, and that link with the hydrostatic steering.

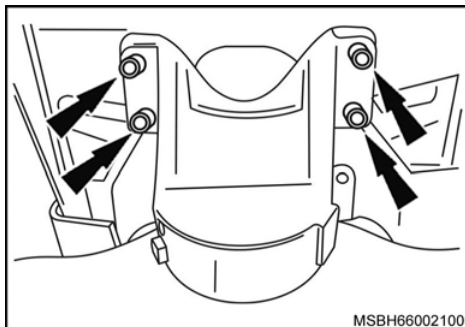

13. RELEASE the fixing screws (arrows) on the front shaft bearings.

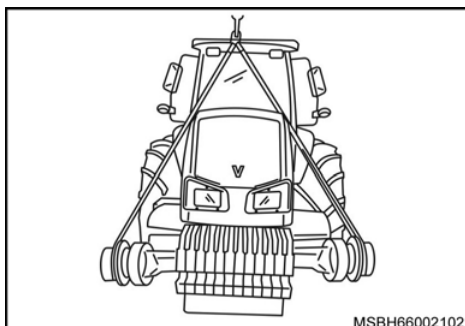
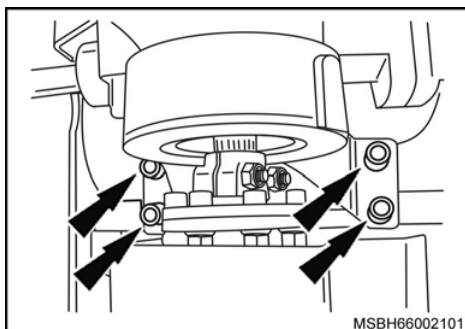

14. LOWER the shaft to remove it and PULL it forward passing under the transversal weights.

Installation

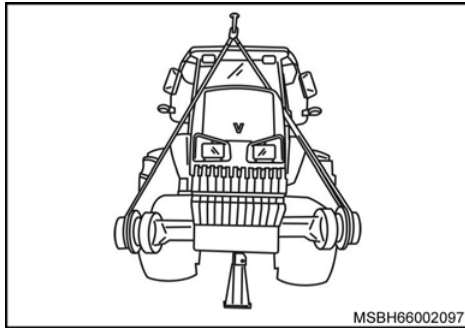

1. **FASTEN** a strap attached to the hook of a hoist or giraffe and the tips at the ends of the front shaft around the hubs, among the prisoners. **RAISE** the shaft.

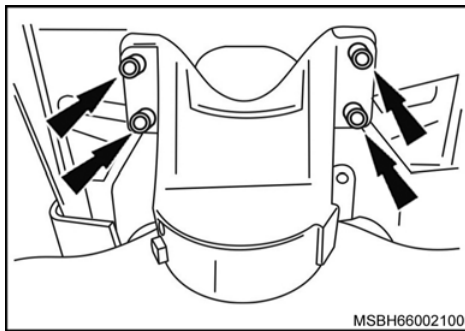
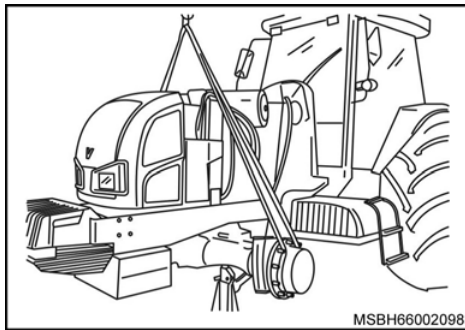

2. **PLACE** the shaft on the bracket, coupling the bearings in a way that the holes are coincident.

INSTALL the screws and **TIGHTEN** them with a torque of 330 N.m.

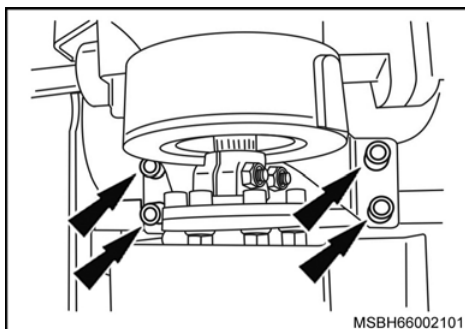

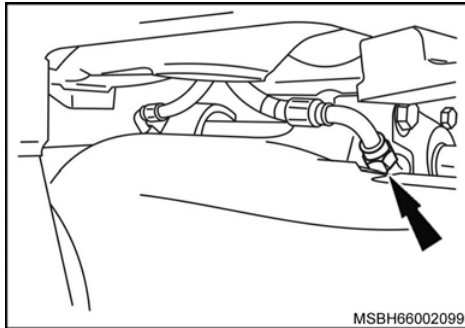

3. MOUNT the fixing nuts (arrows) of the steering hoses, in the front shaft connections, and TIGHTEN them with a torque of 72 - 80 N.m.

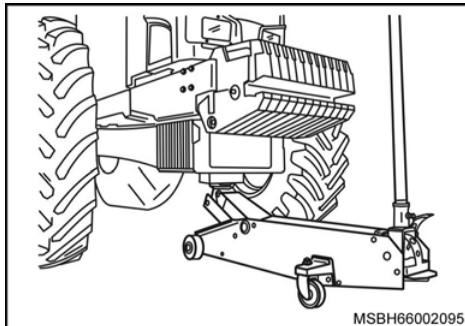

4. PLACE a hydraulic jack under the transversal weights, using it for the shaft to be in an ideal height for the front wheels mounting.

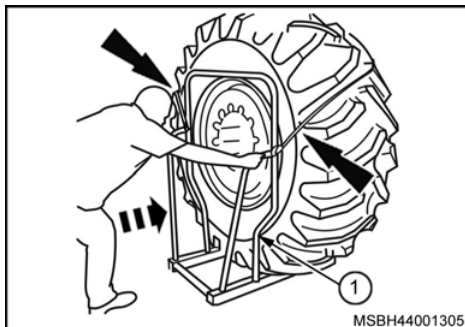

5. USE a stand with the wheels already placed and correctly fastened. PULL the stand in the direction of the hub coupling it in the prisoners. INSTALL the wheels fixing screws and TIGHTEN them with a torque of 600 ± 90 N.m.

6. INSTALL the front wheel on the other side, performing the same procedures as the previous operation.
7. REMOVE the bracket previously placed for the front shaft removal and LOWER the hydraulic jack.

REMOVE the wooden wedges fastened to the front shaft.

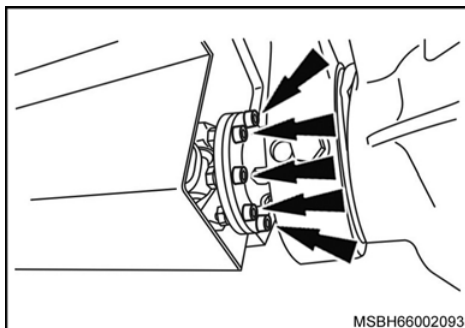

8. PLACE the cardan shaft in the front shaft flange coinciding the holes.

INSTALL the screws with the nuts, tightening with the torque of 54 N.m (5.4 kgf.m).

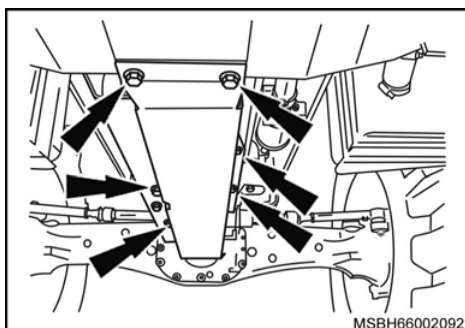

9. PLACE the cardan shaft protector. INSTALL its screws and TIGHTEN them. For information about torque, REFER TO [Section 110-03](#).

REMOVAL AND INSTALLATION

Front differential assembly

Removal

1. REMOVE the front shaft of the tractor. For more information, **REFER TO** the item "[Front Shaft \(Carraro\) – Removal and Installation](#)", in this section.



ATTENTION: to perform the following operations all the work safety equipment necessary (PPE) must be used, e.g., gloves, goggles, shoes, hearing protection, etc.

2. ATTACH the front shaft in the special support, using a hydraulic winch and chains.
3. TIE a suitable chain around the articulating steering, hub and planetary support, embracing them all around, and HOLD the chain over the hook of a hydraulic winch.
4. LIFT a little the hydraulic winch to relieve the tension on the articulations set, hub and planetary support.

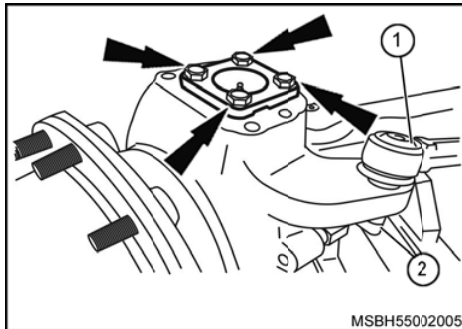

5. REMOVE the fixing nut (1) of the external terminal (2) of the steering bar and REMOVE the terminal with a suitable universal puller.
6. REMOVE the fixing screws (arrows) of the upper and lower pivots of the housing of the steering articulation. REMOVE the mentioned pivots, moving them initially with 2 screwdrivers, taking great care not to damage the existing adjustment shims on top pivots.

NOTE: NOTE the amount and values of the adjustment shims removed to be mounted in the same position.

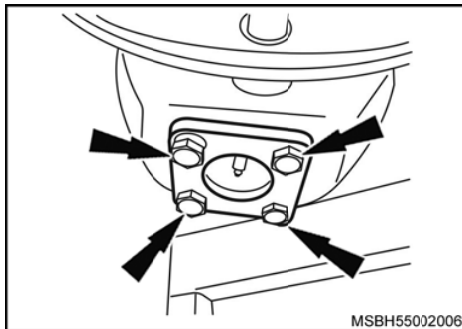

7. REMOVE the complete steering articulation, hub, and planetary support and semi-axis (A), from the front shaft housing, using the hydraulic winch.
8. REPEAT the items 3, 4, 5, 6 and 7 listed above for the other side.

⚠ ATTENTION: when handling bulky and heavy parts, TAKE all necessary safety precautions.

9. LOOSEN the locking nuts of internal fixation (arrows) of the steering bars (1 and 2) and REMOVE THEM, counting and recording the number of turns.

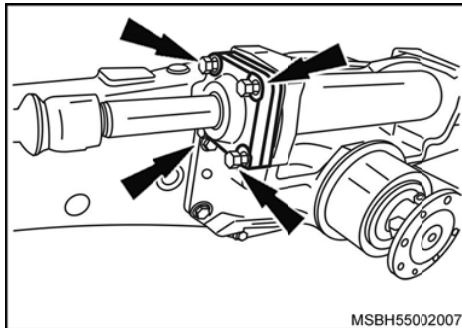

10. REMOVE the fixing screws (arrows) of the steering cylinder.

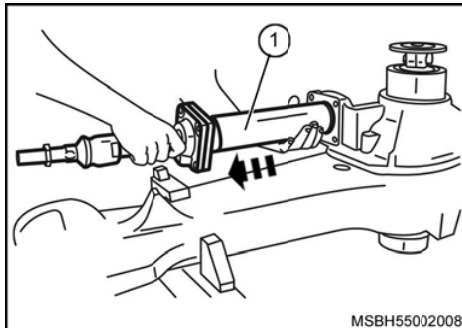

11. REMOVE the steering (1) cylinder from the differential housing.

⚠ ATTENTION: when handling bulky and heavy parts, TAKE all necessary safety precautions.

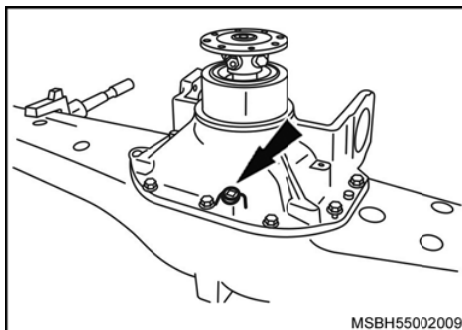

12. PLACE the front shaft housing vertically.
13. PREPARE a suitable container and REMOVE the drain (arrow) plug.
14. DRAIN all oil from the differential. After draining, INSTALL the plug and TIGHTEN IT with a torque of 60 N (6 kgf.m).

NOTE: never dispose lubricating oil into the sewer or any other place that can harm the environment. OBEY the laws of the local municipality.



Suggest:

For more complete manuals. Please go to the home page.

<https://www.ebooklibonline.com>

If the above button click is invalid. Please download this document first, and then click the above link to download the complete manual.

Thank you so much for reading

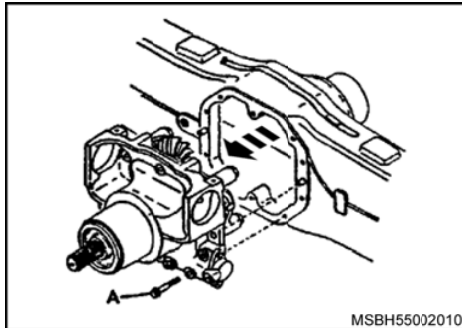

15. REMOVE the 10 fixing screws (A) of the differential assembly (1) to the housing of the front shaft. REMOVE the respective differential assembly, with the aid of a suitable chain and a hydraulic winch.

16. PLACE the differential assembly on a bench.

 **ATTENTION:** when handling bulky and heavy parts, TAKE all necessary safety precautions.

Cleaning

 **ATTENTION:** to perform the following operations all the work safety equipment necessary (PPE) must be used, e.g., gloves, goggles, shoes, hearing protection, etc. Failure to use such equipment may result in serious accidents.

NOTE:

- Do not use gasoline for cleaning the parts.
- Never dispose used transmission lubricating oil, cleaning agents, chemical waste, etc. in the sewage system or any other site that can harm the environment. **OBEY the laws of the local municipality.**
- All the solvent used for cleaning should be collected and adequately stored for recycling.

Housing

Completely CLEAN the interior and exterior of housings, covers, etc. The castings can be cleaned in tanks with weak alkaline solutions (it is recommended to use an aqueous solution 7% degreasing soluble fluid). These parts must remain in the solution long enough to be completely cleaned. The parts cleaned in solution tanks should be thoroughly rinsed in clean water to have all the alkaline traces removed and get dry by compressed air.

 **ATTENTION:** AVOID scratches in the skin, fire hazards and vapors inhalation when using solvents and flammable liquids.

All parts washed should be dried immediately, by using moisture-free compressed air and soft, absorbing, lint-free cloths, avoiding filling materials or contaminated fluid or polishing compounds.

Inspection

INSPECT the front shaft housing and the parts that were removed as: cracks, scratches, cracks, deformations, etc. REPLACE the parts that show any anomaly.

Installation

⚠ ATTENTION: to perform the following operations all the work safety equipment necessary (PPE) must be used, e.g., gloves, goggles, shoes, hearing protection, etc.

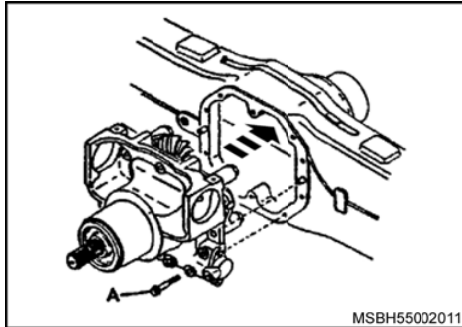

1. APPLY moderately suitable sealing gasket in all the face of the housing union of the differential assembly to the front shaft housing.
2. INSTALL the differential assembly in the front shaft housing, with the aid of a suitable chain and a hydraulic winch.

⚠ ATTENTION: when handling bulky and heavy parts, TAKE all necessary safety precautions.

3. INSTALL the 10 fixing screws (A) of the differential assembly (1) to the housing of the front shaft, and TIGHTEN them with the torque of 170 N.m (17 kgf.m).

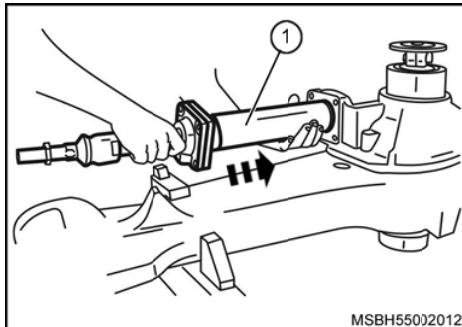

4. INSTALL the steering (1) cylinder from the differential housing.

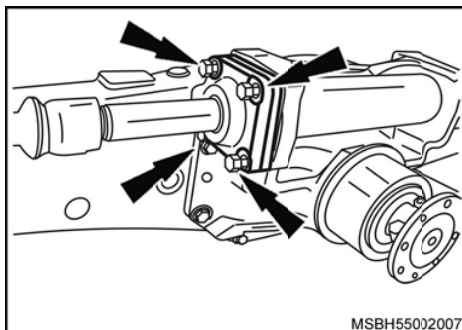

5. INSTALL the fixing screws (arrows) of the steering cylinder. TIGHTEN the cylinder screws with the torque of 120 N.m (12 kgf.m).
6. INSTALL the steering bars, counting the number of turns recorded on removal time.
TIGHTEN the locking nuts (arrows) with the torque of 250 N.m (25 kgf.m).

<https://www.ebooklibonline.com>

Hello dear friend!

Thank you very much for reading.

Enter the link into your browser.

The full manual is available for immediate download.

<https://www.ebooklibonline.com>