

SECTION 440-01 [Print preview](#)

Gearbox

Application in the models: **Heavy Duty**

Table of Contents

Subject
SPECIFICATIONS
HD (EATON) Gearbox technical data
Tightening torque
Adjustments
Clearances
Lubrication
Capacity
Oil filtering
DESCRIPTION AND OPERATION
Gearbox description
Gearbox housing
Transmission axles
Gear selection mechanism
Differential assembly
Lubrication system
Operation
Differential
Gears diagram
DIAGNOSIS AND CHECKS
Manual transmission

Inspection and check
Transmission noises
Oil leak
REMOVAL AND INSTALLATION
Gearbox
Main shaft
Side shaft
Pinion shaft
Differential assembly
Gearbox housing
Oil radiator of the gearbox
Oil filter of the gearbox
Oil filtering element of the gearbox
Oil pump of the gearbox (gearbox installed)
Front ball bearing of the main shaft
Rear ball bearing of the main shaft
Rear ball bearing of the side shaft
Front ball bearings (outer and inner) of the side shaft
Parallel rear ball bearing of the pinion shaft
Conical ball bearings/bearing of the pinion shaft
Conical ball bearings of the differential
First gear
Second gear
Third gear
Fourth gear
Idler third gear
Idler fourth gear
Reverse idler gear

Reverse group gear
M group gear
H group gear
L group gear
Cap and hub of the first and second gears
Cap and hub of the third and fourth gears
Cap and hub of the reverse and M gears
Cap and hub of the H and L groups
Ring gear and pinion assembly
Differential assembly
Differential assembly cover
Assembly of the planetary gears and differential satellites
Thrust rings of the planetary gears of the differential
Bronze shims of the gears and differential satellites
Differential blocking spring
DISASSEMBLY AND ASSEMBLY
Gearbox
Main shaft
Side shaft
Pinion shaft
Differential assembly
Levers box

<https://www.ebooklibonline.com>

Hello dear friend!

Thank you very much for reading.

Enter the link into your browser.

The full manual is available for immediate download.

<https://www.ebooklibonline.com>

SPECIFICATIONS [Print preview](#)

HD (EATON) Gearbox technical data

Description	Specification
Type of transmission	Manual, non synchronized
Number of gears forward	12
Number of reverse gears	4
Differential transmission relation - number of teeth	4.55:1 - 9/41

Tightening torque

Description	N.m
Fastening nuts from the differential ring gear	130...143
Bearing fixing screws of the pinion shaft conical ball bearings	70...80
Pinion shaft fastening nuts	270...350
Differential bearings covers fastening nuts	97...117
Fuel tank gearbox fixing screws	200...220
Side shaft fastening nuts	270...350
Fixing screws of the side shaft cover	70...80
Fixing screws of the brake housing to the gearbox	270...330
Oil pump fixing bolts	23...28
Fixing screws of the gearbox upper cover	80...90
Fixing screws of the oil radiator connections support	40...50
Wheels fastening nuts	570...690

Adjustments

Description	N.m
Preload of the conical ball bearings of the differential	6...9.6
Preload of the conical ball bearings of the pinion shaft	19...36

Clearances

Description	mm
Clearance between the ring gear and the pinion	0.17...0.32
Clearance between the idler gears of the reverse and fourth gears of the main shaft	0.17...1.00
Clearance between the gears of the second and third gears of the main shaft	0.19...0.77

Lubrication

Description	Specification
Lubrication mode	Under pressure, splash and immersion.
Oil for manual transmission of high pressure.	SAE 90 API GL 5

Capacity

Description	Liters
Gearbox	55
Oil filter of the transmission	0.75

Oil filtering

Description	Specification
Filtering capacity of the transmission filter	125 um
Opening of the relief valve of pressure	1.0...1.5 bar
Indicator light of oil pressure and temperature	Instrument panel

DESCRIPTION AND OPERATION [Print preview](#)

Gearbox description

The gearbox can be defined as a set of gears that allow the selection of transmission ratios to match the power developed by the engine with the speed and the workload. These transmission ratios are called gears.

The gearbox of these Valtra tractors has 12 forward gears and 4 reverse gears.

The type of gearbox of the Valtra tractors is of 3 axes, arranged in a triangular formation, classified within the group termed as constant gear. This means that the gears have no movement in the longitudinal direction to effect the engagement of any gear. Therefore, synchronizers or thrust rings are used.

The gearbox basically consists of the following components:

- gearbox housing;
- transmission axles;
- gear selection mechanism;
- differential assembly;
- lubrication system.

Gearbox housing

The gearbox housing is a cast iron frame divided into two compartments. The front compartment supports the set of three axes of the transmission and the drive shaft of the transmission system of the front shaft (tractors with 4x4 traction) and the rear compartment supports the differential assembly. On the side walls of the rear compartment the final drive gears are attached; on the rear wall the power take-off mechanism; on the top cover the hydraulic lift mechanism.

Transmission axles

Main shaft

The transmission input shaft is driven directly by the input shaft of the clutch or by the drive shaft of the speed multiplier. The coupling between the two is done through a splined sleeve.

The main shaft is of hollow construction to allow the passage of the drive shaft of the power take-off. Its rear end is provided with grooves or slots to drive the oil pump of the lubrication system.

The main shaft is supported on the front and intermediate walls of the housing through cylindrical roller ball bearings. We find in the main shaft the synchronizer that drives the gears of the gear selectors 3 and 4 (in each group).

All the main shaft gears are in constant engagement as the ones in the lateral axis, with the exception of the reverse idler gear, which also engages with the engagement of the reverse group gear of the conical shaft of the pinion.

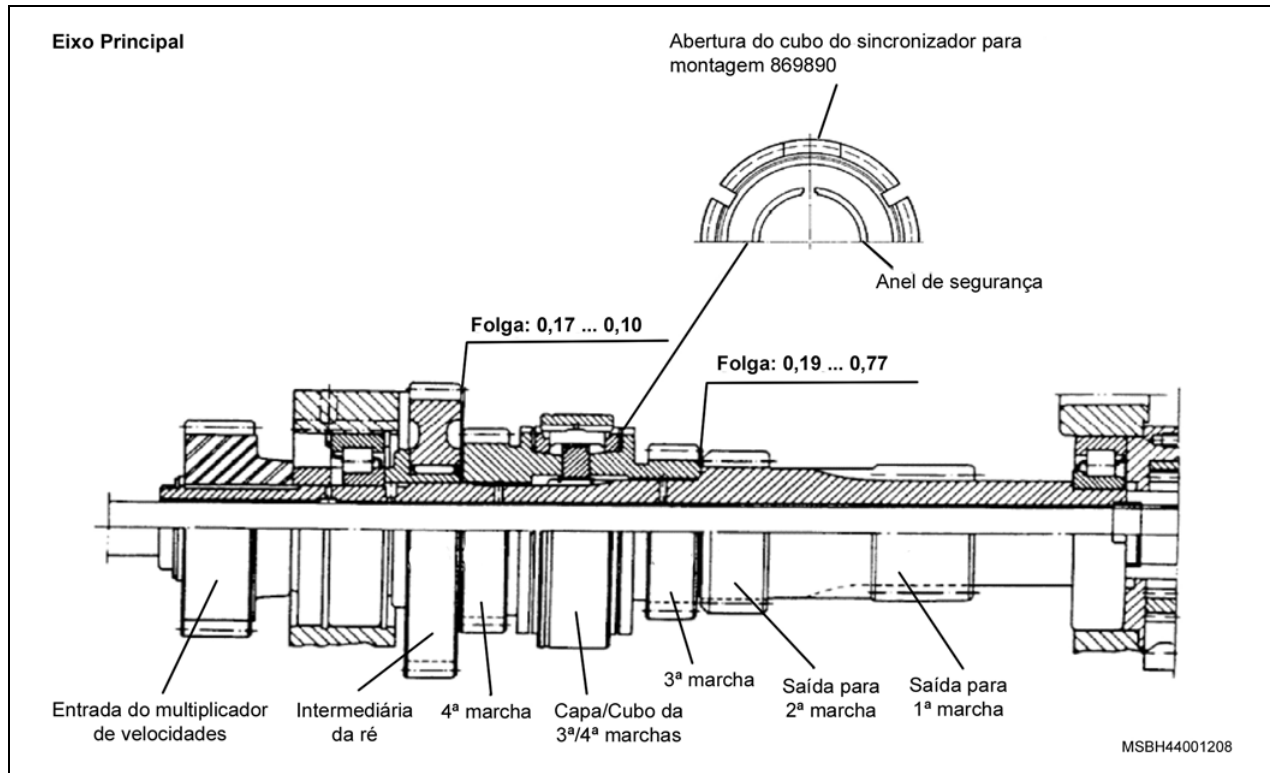

Side shaft

The lateral axis, also known as the intermediate shaft, is supported by cylindrical roller ball bearings on the front wall and in the intermediate of the gearbox housing.

It lies on the shaft beside the sleeve that drives the selector gears 1 and 2 (in each group).

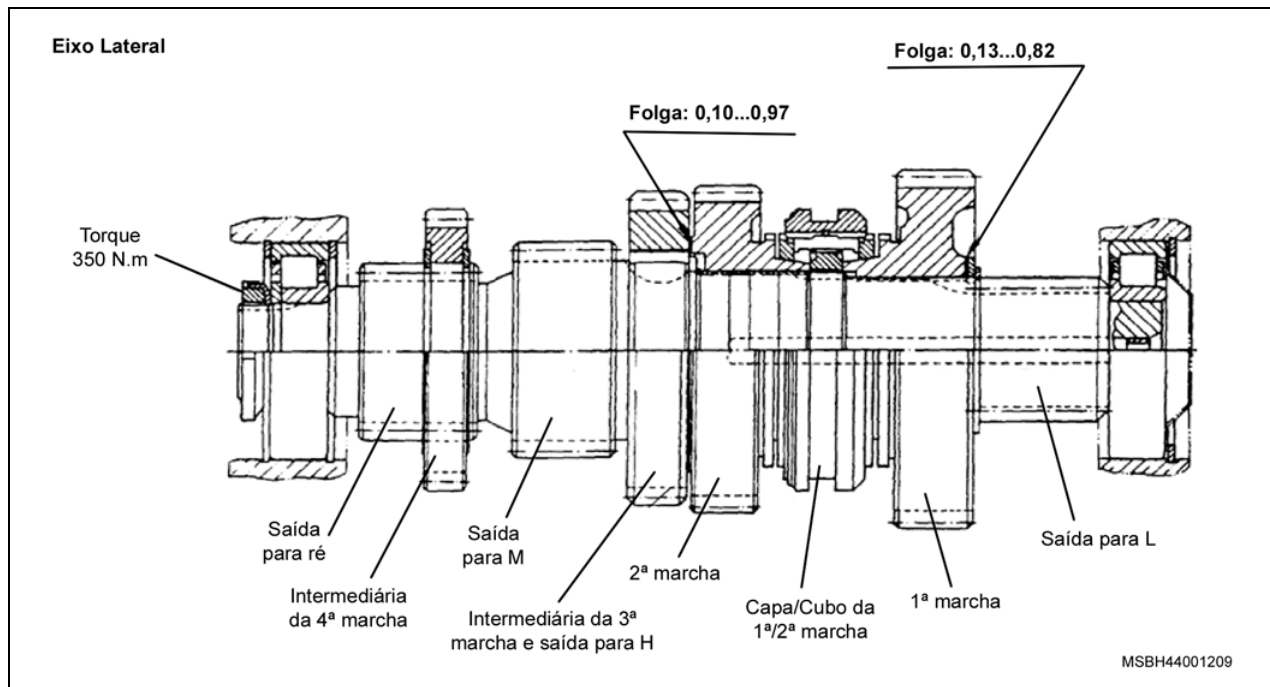

Conical shaft of the pinion

It is the power output shaft to the crown of the differential assembly and in the 4x4 models it also serves to actuate the PTO of the front traction shaft.

The pinion shaft is supported in the front wall by a bearing provided with two conical ball bearings and the intermediate wall by a bearing of cylindrical rollers.

In the conical shaft of the pinion are the two coupling rings which control the four (4) groups of gears (L, M, H, R).

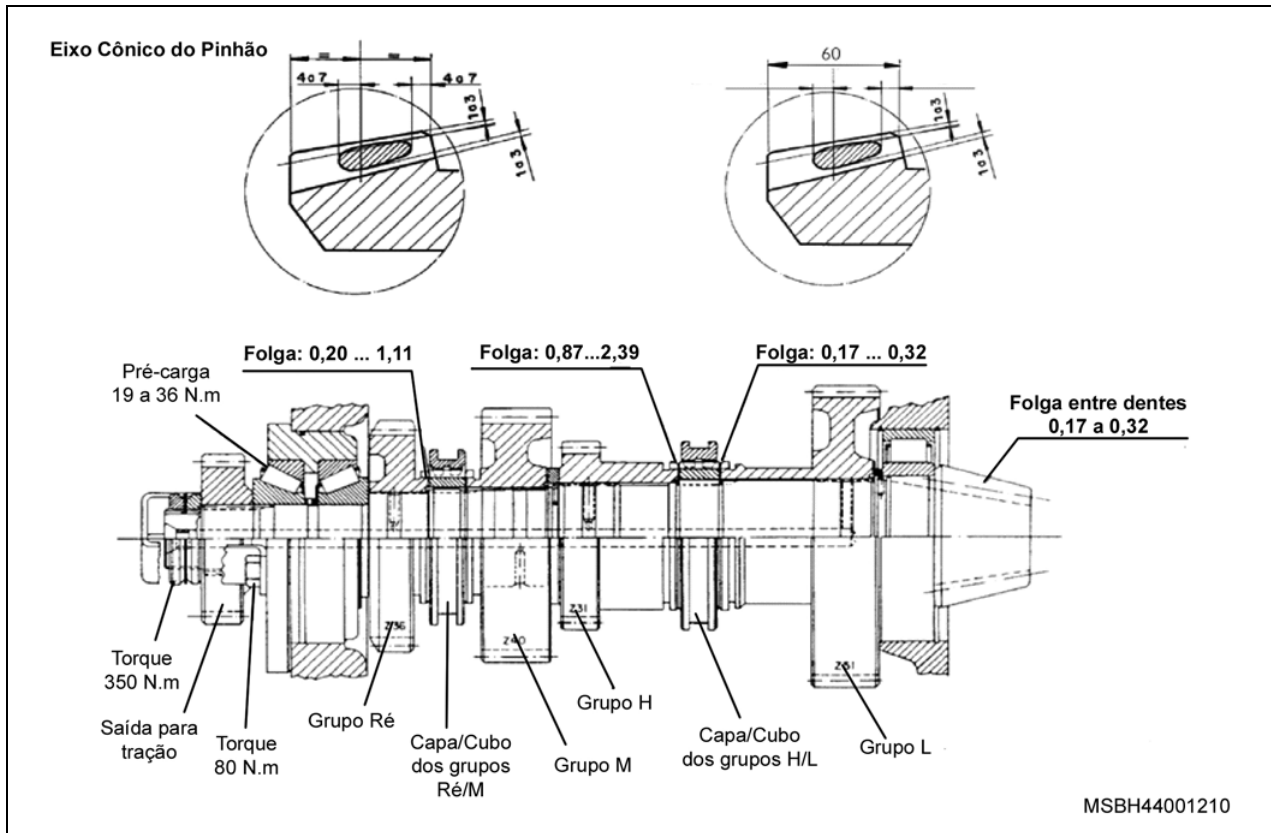

EIXOS DA CAIXA NÃO SINCRONIZADA H.D. PESADA

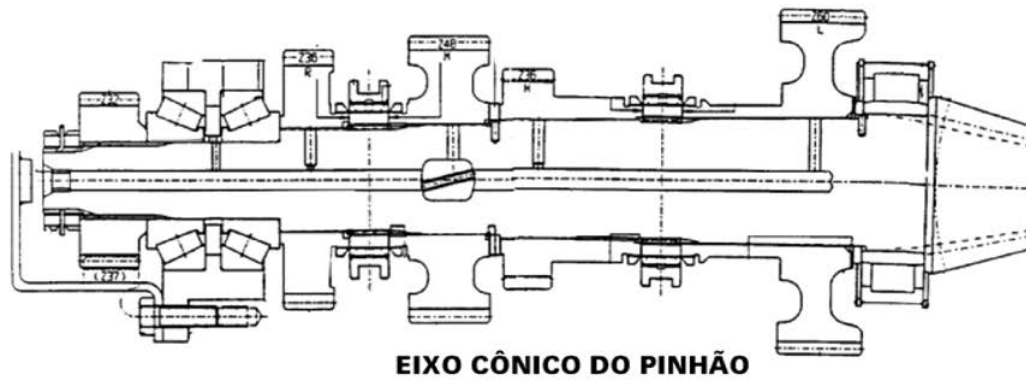
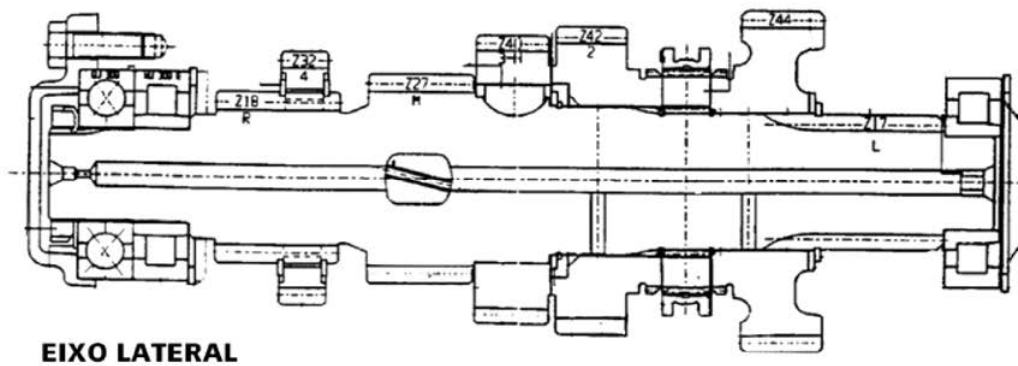
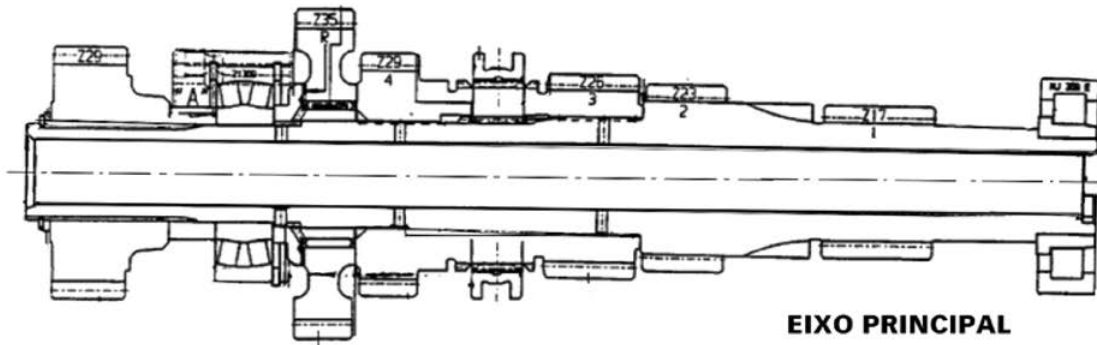

Gear selection mechanism

The displacement of the coupling rings performs the coupling of the gears through the forks controlled by the levers. Each lever drives 2 forks. The gears selector mechanism is located on the right side of the gearbox housing itself. The locking mechanism of the selectors shafts is constructed in the conventional form of balls loaded by springs.

Differential assembly

The differential is supported through 2 bearings provided with conical ball bearings. The differential gear comprises two planetary gears, 4 satellite gears and the block system. The differential lock is actuated by a pedal (located on the right side of the tractor), blocking the planetary gear with the differential housing, causing the tight coupling between the two rear half shafts of the final transmission.

If the teeth of the locking device do not couple when the pedal is pressed, there is a spring that helps and controls the coupling sleeve, making the coupling in the next moment.

Lubrication system

The lubrication of the transmission system is effected by immersion, splash and under pressure.

The components that receive lubrication under pressure are: the main shaft, the lateral shaft, the pinion shaft, the ball bearing of the PTO, ball bearings of the speed multiplier.

The system has as a main component the gears type oil pump, which is directly driven by the main shaft. There is still in the system a replaceable oil filter and pressure regulators valves. The system also has the lubricating oil cooling through radiator.

Operation

The following figures illustrate the combinations of gears for the different exchange gears.

Differential

The differential is attached to the rear cavity of the exchange gearbox and is supported by two bearings provided with conical ball bearings.

The differential comprises 2 planetary gears, 4 satellite gears and the locking system, located on the side of the tractor.

The differential block is actuated by a pedal (located on the right side of the tractor) and, when triggered, the system blocks the planetary gear with the differential housing, causing the tight coupling between the two rear half shafts of the final transmission. If the teeth of the locking device do not couple when the pedal is pressed, there is a spring that adjusts and controls the coupling sleeve, making the coupling in the next moment.

Gears diagram

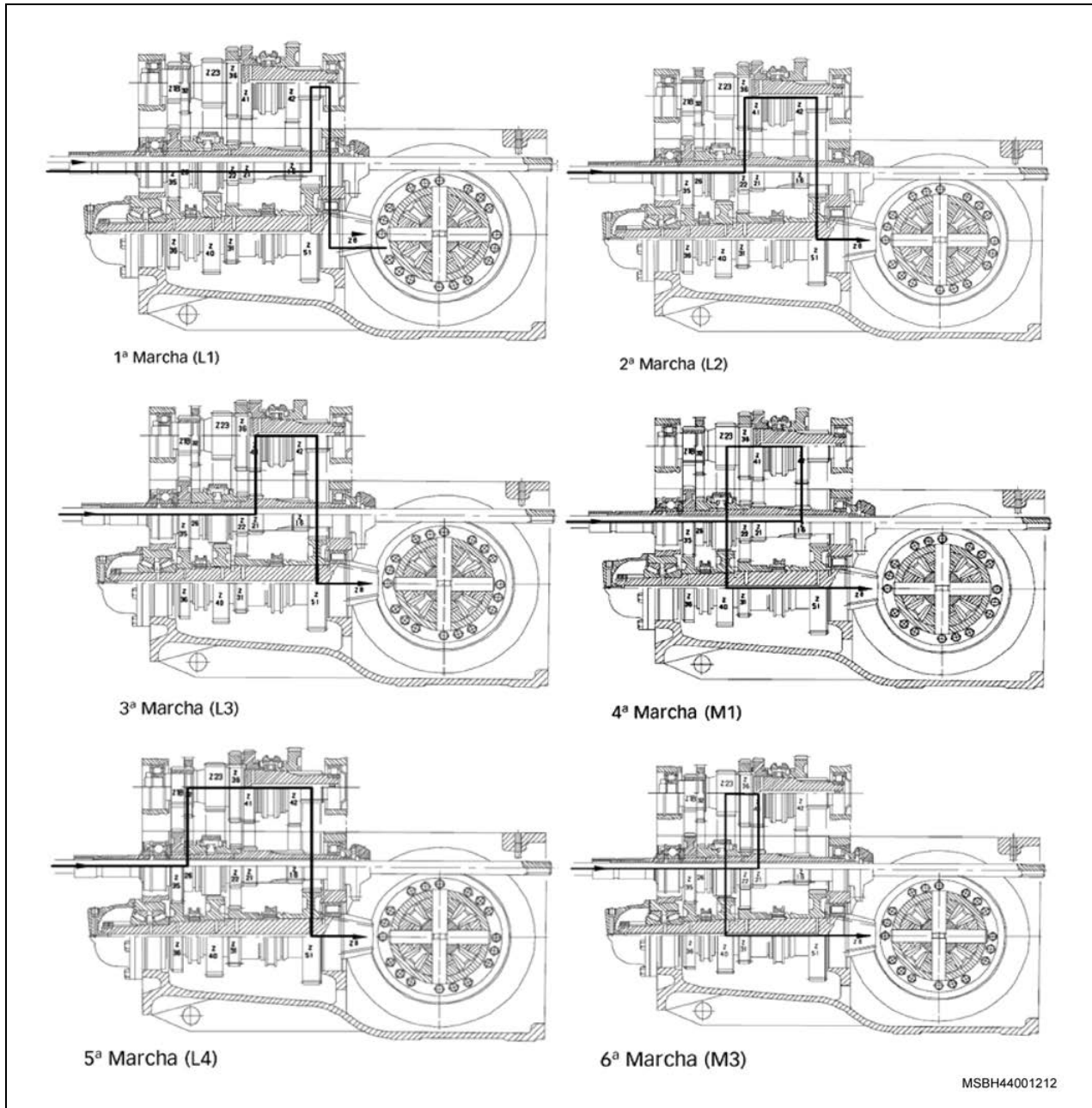

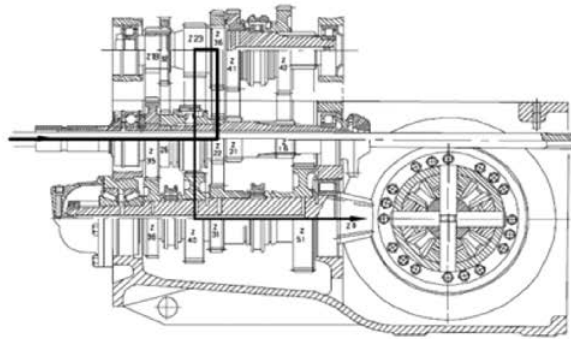

7ª Marcha (M4)

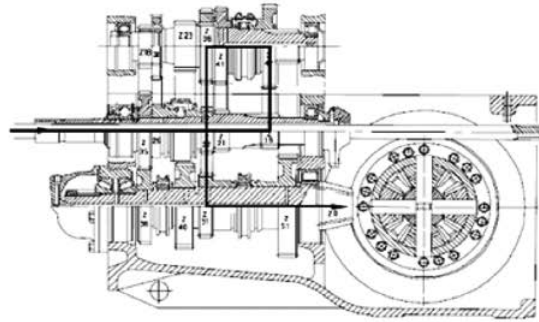

8ª Marcha (M2)

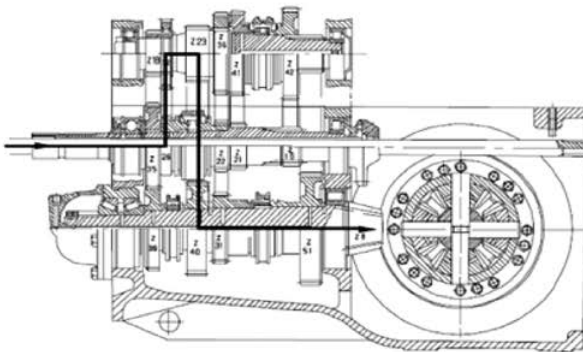

9ª Marcha (H1)

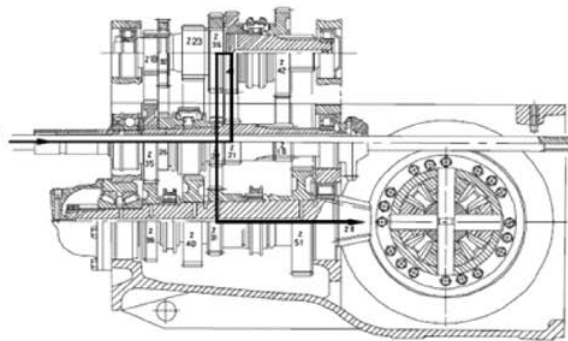

10ª Marcha (H2)

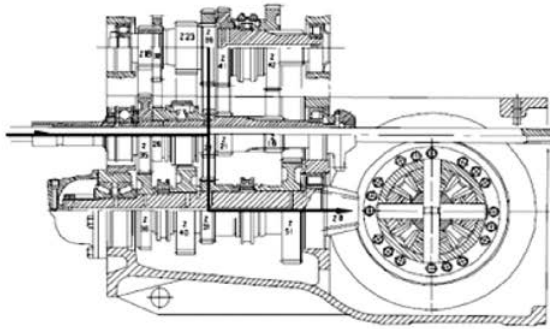

11ª Marcha (H3)

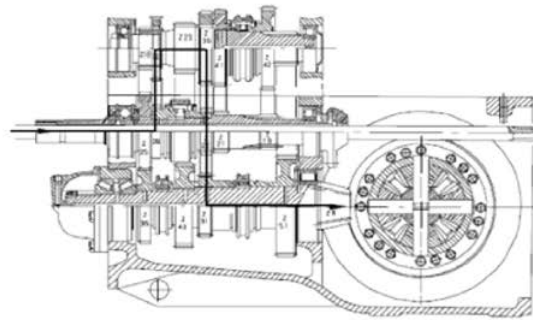

12ª Marcha (H4)

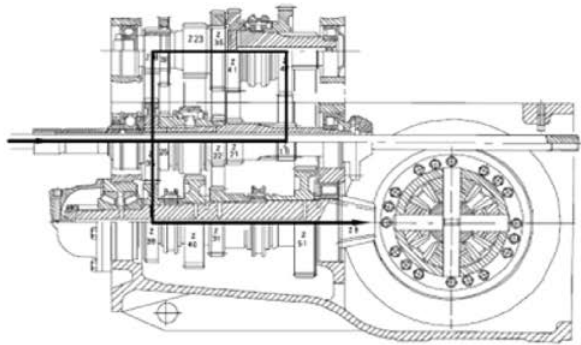

1ª Marcha à ré (R1)

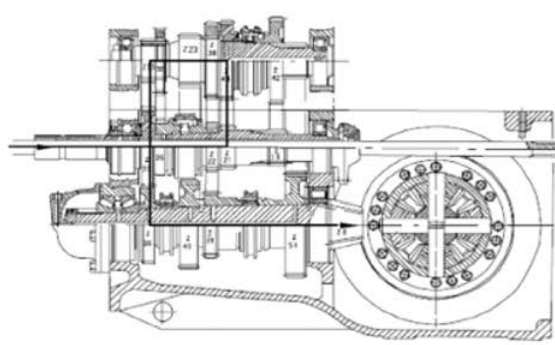

2ª Marcha à ré (R2)

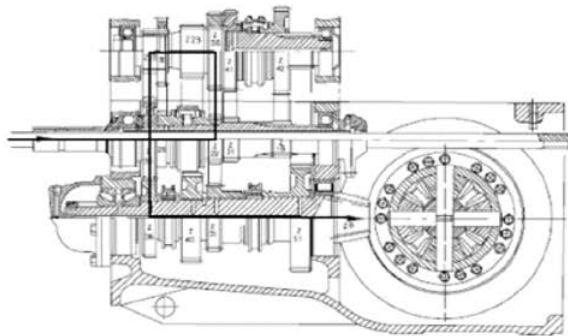

3ª Marcha à ré (R3)

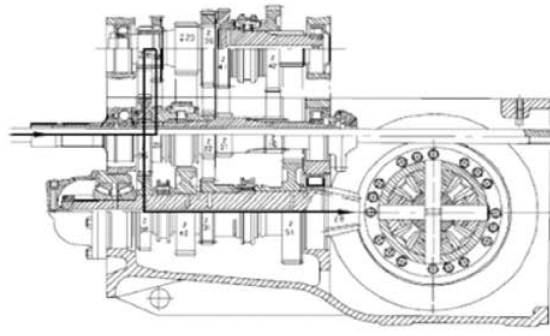

4ª Marcha à ré (R4)

MSBH44001214

DIAGNOSIS AND CHECKS [Print preview](#)

Manual transmission

Inspection and check

1. CHECK the Operator complaint.
2. Visually INSPECT for obvious signs of mechanical damage.

Visual Inspection Chart

Mechanic
<ul style="list-style-type: none">• Oil filter leakages of the gearbox• Damaged or worn parts• Nuts and bolts loose or missing

3. If an obvious cause is found for a problem observed or reported, CORRECT the cause (if possible) before moving to the next step.

Transmission noises

1. CHECK the support of the engine and transmission for insufficient clearance between the gearbox and other components.
2. CARRY OUT a field test.
3. If a noise is detected in several gears in the same engine speed, CHECK and see if the noise occurs in dead center. If it does, it is not caused by the gearbox.

Oil leak

1. CHECK the gearbox fluid level. If necessary, DRAIN any excess of fluid.
2. Carefully CLEAN the gearbox and the surrounding areas and TEST the tractor in the field.
3. Using the ultraviolet equipment to detect fluid leaks, FIND the leak and CHECK and see if the fluid that is leaking is from the transmission, the steering, the brakes or the engine.

REMOVAL AND INSTALLATION [Print preview](#)

Gearbox

Removal



ATTENTION: to perform the following operations all the work safety equipment necessary (PPE) must be used, e.g., gloves, goggles, shoes, hearing protection, etc.

NOTE: for removing and installing the gearbox it is necessary to remove the air conditioned acclimatized cabin. Therefore, before removing the cabin, **WASH** the tractor carefully enough as to not allow water into the cabin. Only **CLEAN** inside the cabin with a vacuum cleaner or compressed air.



CAUTION: if the cabin is washed inside, the instruments of control of the roof may be damaged and cause odors and mold in the coatings.



ATTENTION: when handling bulky and heavy parts, **TAKE** all necessary safety precautions.

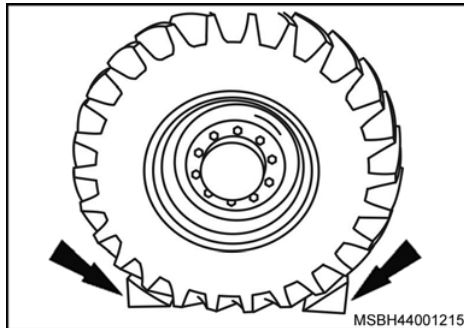

1. APPLY the parking brake and SHIM the front wheels with wooden wedges on the front and on the back (arrows).

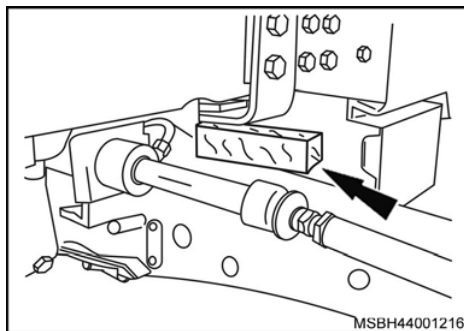

2. SHIM the front axle beam with wooden wedges (arrow), in both sides, in order to assure the side balance of the front assembly.

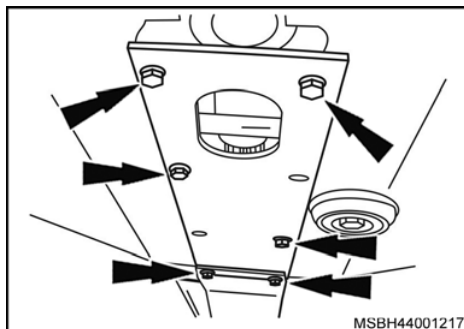

3. REMOVE the cardan rear protection (1), removing the fixing screws (arrows).

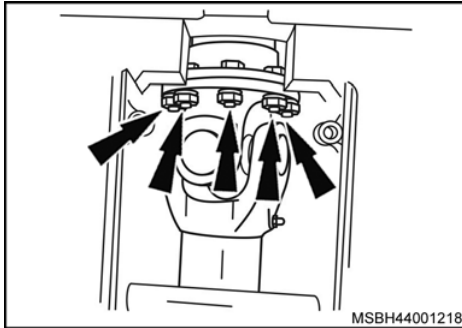

4. REMOVE the 8 fixing bolts (arrows) of the rear fixing flange of the front traction cardan and DISENGAGE IT.

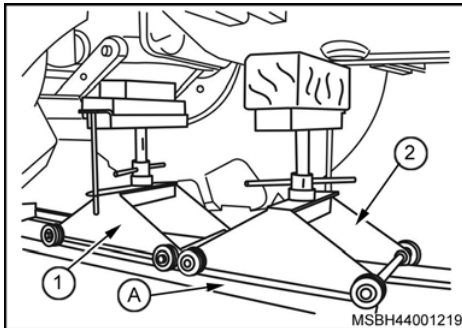

5. PLACE a rail (Equipment "A") under the tractor and USE 2 carts (1 and 2) with height adjustment on the rails.
6. PLACE the cart (1) under the gearbox and the cart (2) under the fuel tank, adjusting them to touch the components carcass.

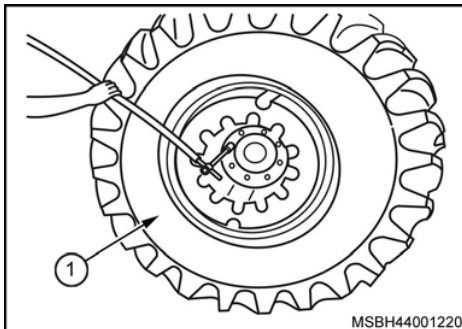

7. RELEASE, without removing, the fastening nuts of the rear wheels (1).

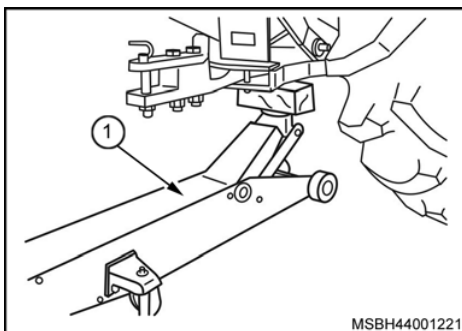

8. POSITION the hydraulic jack (alligator) (1) (CAP. 10 T) under the traction hook.

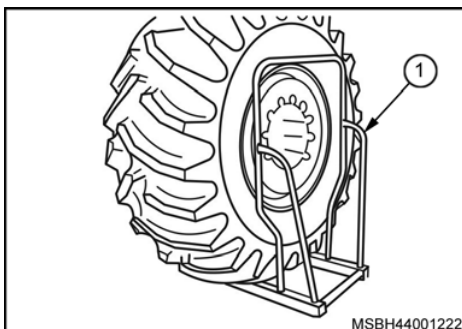

9. LIFT the hydraulic jack until both wheels are free from the floor and you can install the special cart (Equipment 1) under both wheels to remove them (USE 2 equal special trolleys).
10. Slowly LOWER the hydraulic jack until the wheels rest on the special carts and the wheels studs are free without tension.

At this point, ADJUST again the support carts of the fuel tank and the gearbox, raising them to touch the housing of the components.

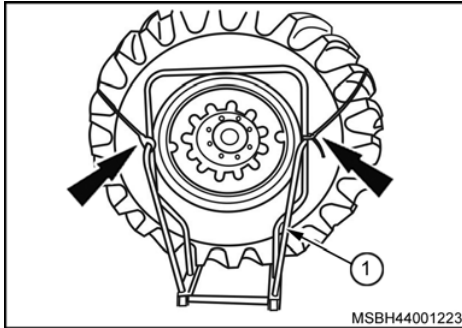

11. ATTACH the wheel on the special cart (1) involving the tire with a safety strap (arrows) and attaching it to the cart.

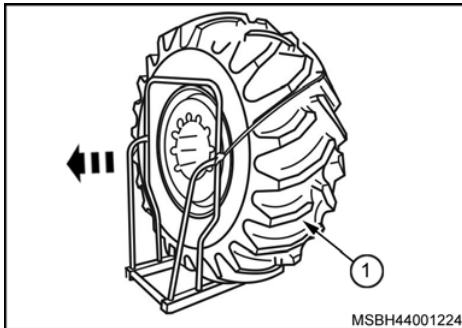

12. REMOVE the tractor wheel (1) by carefully pulling it out of the studs of the wheel hub.
13. REPEAT the above operation for the wheel on the opposite side and LOWER and REMOVE the hydraulic jack.

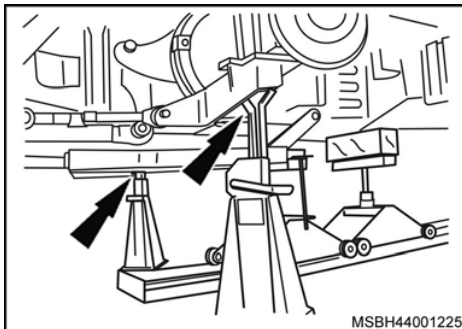

NOTE: for increased safety for removal and installation of the gearbox, SHIM with two more brackets in the area of the housings of the final drive (arrows).

14. REMOVE the air conditioned acclimatized cabin. For more information, REFER TO the item "[Air conditioned acclimatized cabin \(BH\) – Removing and installing](#)", on [Section 880-01](#).

NOTE: in case the drainage of the hydraulic system has not yet been done at the moment of the removal of the cabin, PROCEED to the drainage. For more information, REFER TO the item "[Hydraulic System – Drainage and Supply](#)", in [Section 990-01](#).

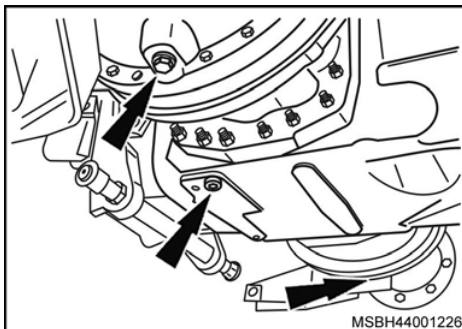

15. PREPARE a suitable container and DRAIN the oil from the gearbox and the final drives by removing the drain plugs (arrows).

After draining the oil, INSTALL and TIGHTEN the plugs.

NOTE: all the used lubricating oil must be adequately collected and stored for later recycling.

NOTE: all hoses and loose connections in general should be capped to prevent contamination and leakage.

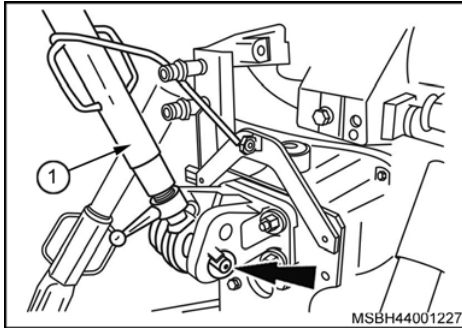

16. REMOVE the upper coupling bar (1) by removing the lock and the mounting pin (arrow).

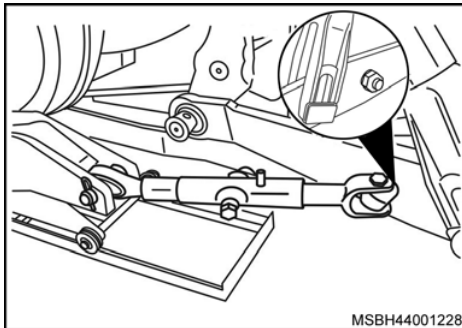

17. REMOVE the stabilizer bar (1) on both sides by removing the cotter pin and the mounting pin (arrow) and the cotter pin and the fastening nut (2).

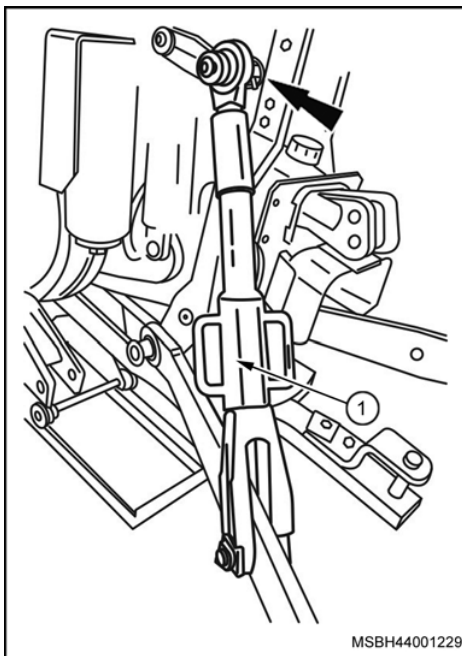

18. REMOVE the lifting connection bar (1) on both sides, removing the locks and the mounting pins (arrows).

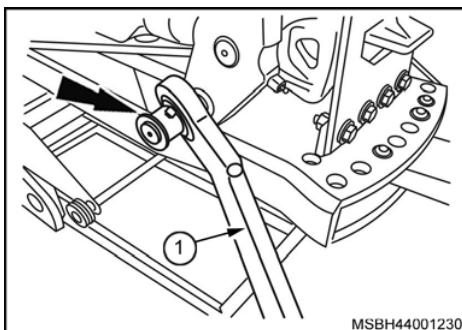

19. REMOVE the coupling bar (1) on both sides by removing the lock pin and the guide bushing (arrow).

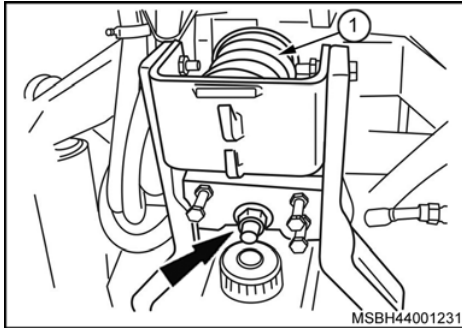

20. LOOSEN the mounting nut (arrow) from the feeler arm assembly, MOVE the respective assembly backwards and REMOVE the feeler spring (1).

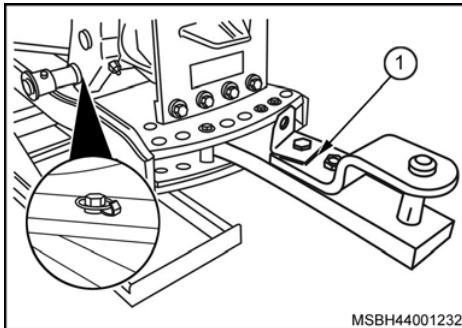

21. REMOVE the lower coupling bar (1) by removing the lock and the mounting pin (arrow).

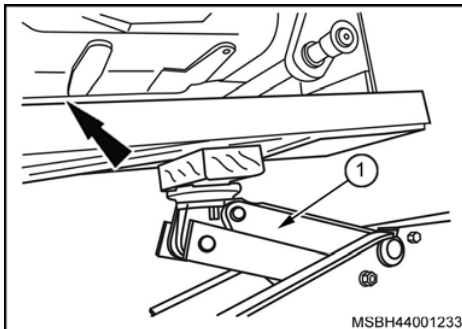

22. PLACE an alligator-type hydraulic jack (1) under the traction hook (2) and LIFT it until it touches the hook bottom (arrow).

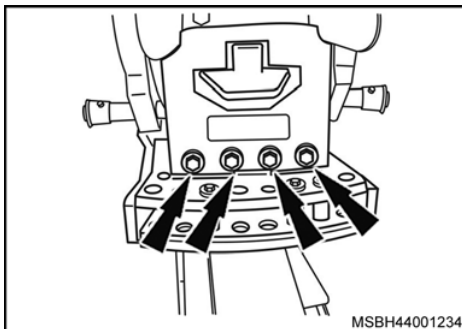

23. REMOVE the screws fixing (arrows) the traction hook to the PTO support.

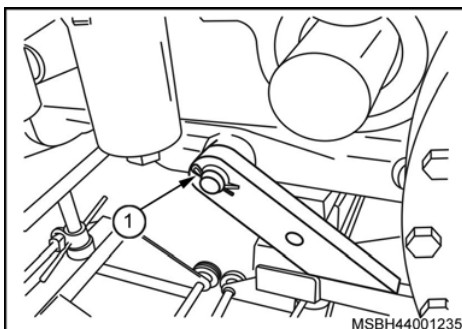

24. REMOVE the cotter pin (1) of the joint shaft for fixing the traction hook and REMOVE the shaft, tapping with a soft bar and a hammer (arrow). After removing the shaft, LOWER and REMOVE the hydraulic jack, together with the traction hook.

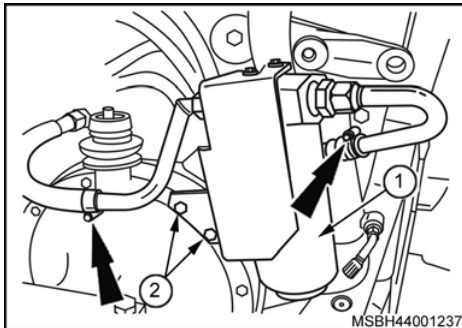
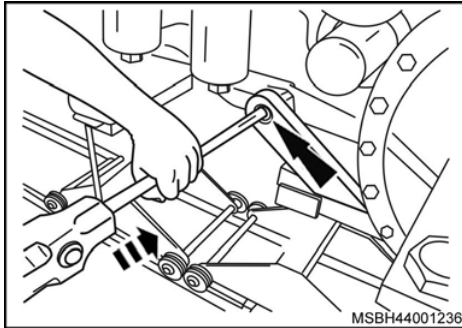

25. REMOVE the suction filter (1) of the hydraulic system, releasing the oil inlet and outlet hoses (arrows), removing the fixing screws (2) from their support.

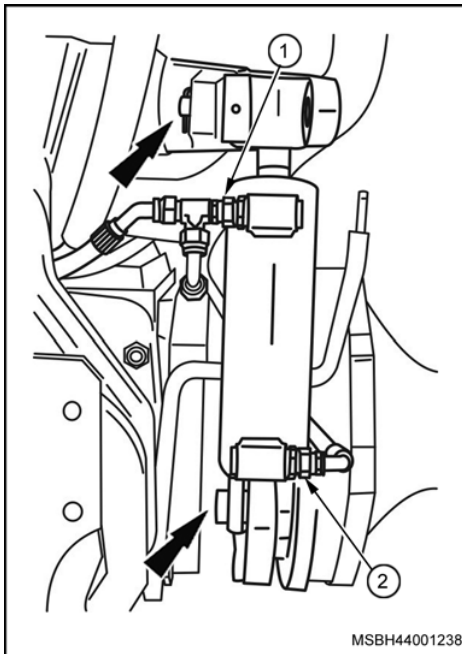

26. RELEASE the connections (1 and 2) of the oil inlet and outlet hoses of the lift auxiliary cylinder. REMOVE the respective cylinder, removing the cotter pins and the mounting pins (arrows) on both sides.

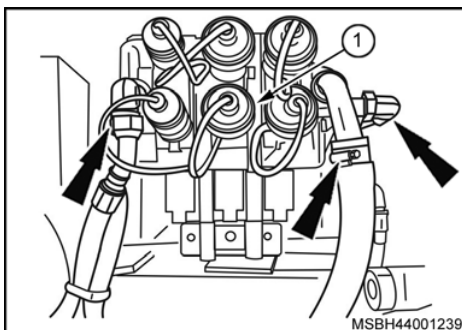

27. RELEASE the connections (arrows) of the low and high oil pressure hoses of the hydraulic system of the body of command of 3 valves (1) and of the HiFlow valve (2).



Suggest:

For more complete manuals. Please go to the home page.

<https://www.ebooklibonline.com>

If the above button click is invalid. Please download this document first, and then click the above link to download the complete manual.

Thank you so much for reading

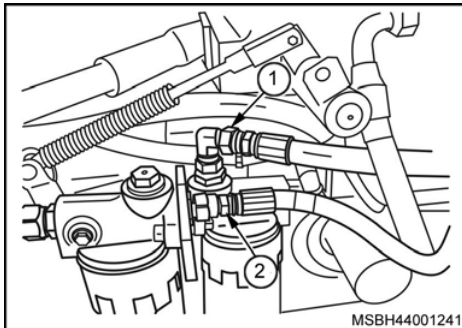
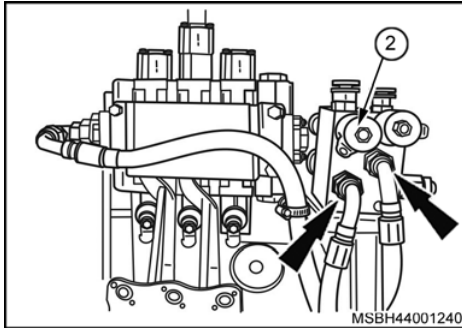

28. RELEASE the connections (1 and 2) the high-pressure hoses for hydraulic system power at the outlet of the oil filters.

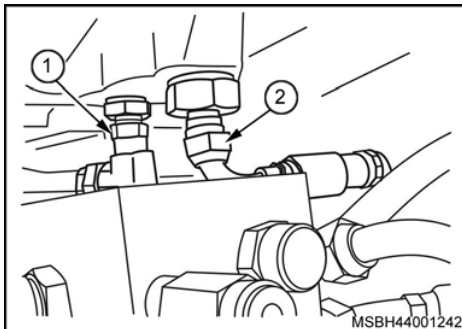

29. RELEASE the connections (1 and 2) of the high-pressure hoses for the hydraulic system power at the housing inlet of the hydraulic lift (gearbox cap).

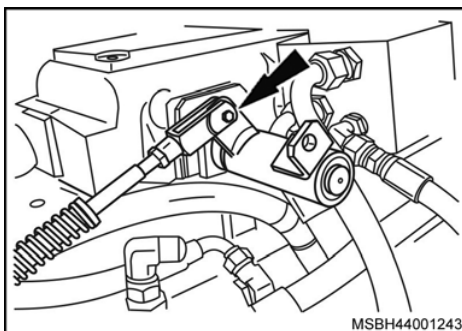

30. RELEASE the speeds multiplier drive rod coupling, removing the cotter pin and the mounting pin (arrow).

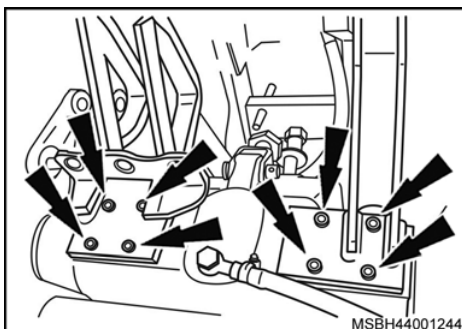

31. REMOVE the body of command of 3 valves and the HiFlow valve of the hydraulic system, together with the supports, removing the fixing screws (arrows).

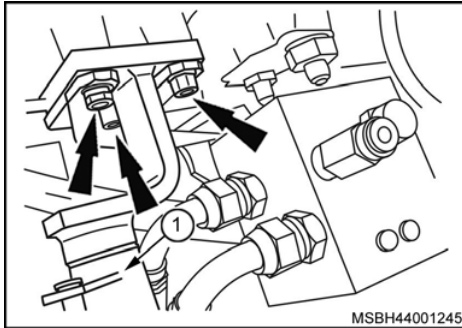

32. REMOVE the junction block (1) together with the hoses and the support, removing the fixing screws (arrows).

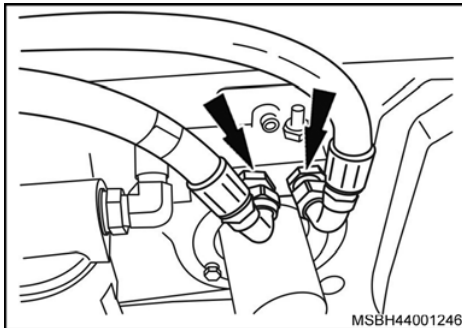

33. RELEASE the gearbox oil cooling system oil hoses connections (arrows) in the housing.

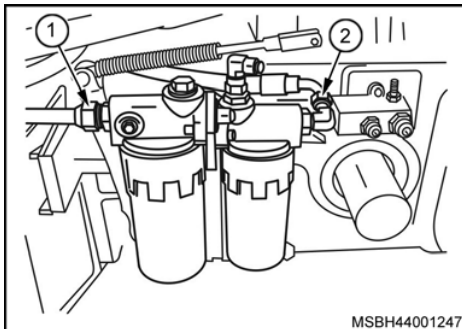

34. RELEASE connections (1 and 2) the high-pressure hoses for hydraulic power at the entrance of oil filters.

35. REMOVE both oil filters in conjunction with the support, removing the fixing screws (arrows).

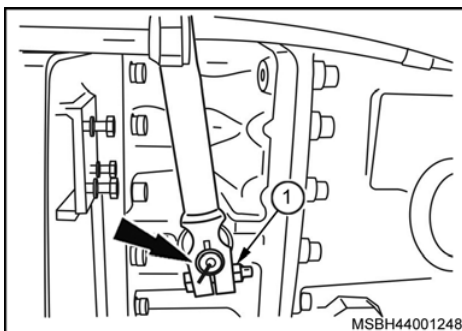

36. MAKE a reference mark on the shaft and multiplier speeds drive lever (arrow) to facilitate assembly and REMOVE the respective lever by removing the fixing screw (1).

<https://www.ebooklibonline.com>

Hello dear friend!

Thank you very much for reading.

Enter the link into your browser.

The full manual is available for immediate download.

<https://www.ebooklibonline.com>