

KOBELCO

SERVICEMAN'S HANDBOOK
HYDRAULIC EXCAVATOR
SR SERIES

KOBELCO

SR
Series

SERVICEMAN HANDBOOK

SK15SR	PU06001~
SK20SR	PM02001~
SK25SR	PV10001~
SK30SR	PW07001~
SK35SR	PX05001~
SK40SR	PH00101~
SK45SR	PY06001~

KOBE STEEL

Book code No. S7PU00001ZE01
1997.12 (K·E·F)

CONTENTS

1. DIMENSIONS IN TRANSPORTATION FIGURES	1
2. MACHINE SPECIFICATIONS	2
3. COMPONENTS SPECIFICATIONS	4
3-1 Engine specifications	4
3-2 Hydraulic equipment	13
3-3 Hydraulic cylinder	16
4. PERFORMANCE	19
4-1 Performance list	19
4-2 Noise level	20
5. WEIGHT OF COMPONENTS	21
6. DESIGNATED OIL AND GREASE, AND FILTER ELEMENT	24
6-1 Oil and grease list	24
6-2 Fitting positions of filter elements, etc.	25
7. PRESSURE AND PERFORMANCE STANDARD	27
7-1 Pressure measuring and adjusting methods	27
7-2 Performance measuring methods	34
8. PERFORMANCE STANDARD	39
9. HYDRAULIC DIAGRAM	48
10. ELECTRIC DIAGRAM	62
11. DIMENSIONAL DRAWING OF ATTACHMENTS	68

<https://www.ebooklibonline.com>

Hello dear friend!

Thank you very much for reading.

Enter the link into your browser.

The full manual is available for immediate download.

<https://www.ebooklibonline.com>

12. MAINTENANCE STANDARD	77
12-1 Clearance between pins and bushings	77
12-2 Forms and dimension of pins	85
12-3 Undercarriage	89
13. WORKING RANGE OF ATTACHMENTS	100
14. LIFTING DIAGRAM	106
15. REFERENCE DATA	111
15-1 Flared joint	111
15-2 "ORS" joint	111
15-3 Plug for hose	112
15-4 Torques for nuts and sleeve	113
15-5 Fitting N ₂ (Nylon) tube joint	114
15-6 Flareless joint	114
15-7 Tightening torques for capscrews and nuts	115
15-8 Lever patterns	116
15-9 Special spanner for tube	116
16. TABLE OF CONVERSION RATE	117
16-1 International unit	117
16-2 Conversion table	118
16-3 Pressure conversion table	120
16-4 Incline conversion table	121
16-5 Temperature conversion monogram	122

1. DIMENSIONS IN TRANSPORTATION FIGURES

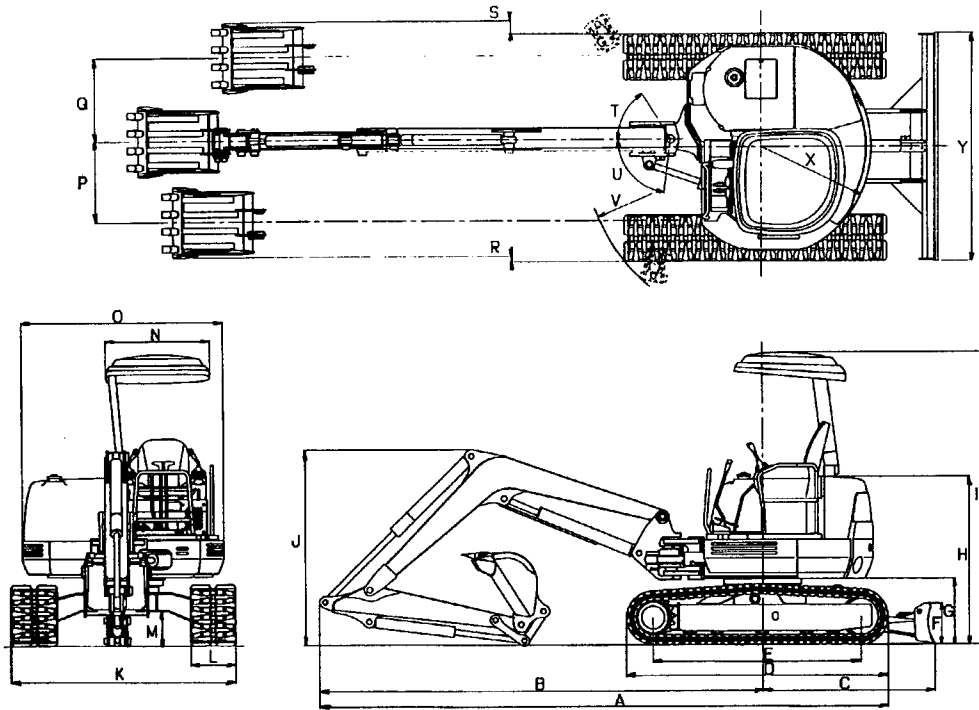

Unit : mm

Model \ Code	A	B	C	D	E	F	G	H	I	J	K	L	M
SK15SR	3,600	2,790	1,250	1,630 [1,600]	1,250	260	450	1,170	(2,330) 2,380	1,190	1,350	230	215
SK20SR	3,810	2,930	1,260	1,710 [1,680]	1,350	260	450	1,170	(2,330) 2,380	1,390	1,400	250	210
SK25SR	4,110	3,140	1,340	1,900 [1,870]	1,435	330	570	1,400	(2,510) 2,480	1,380	1,550	300	290
SK30SR	4,400	3,350	1,370	2,010 [1,970]	1,540	330	570	1,400	(2,510) 2,480	1,415	1,550	300	290
SK35SR	4,740	3,590	1,500	2,210 [2,170]	1,740	330	570	1,400	(2,510) 2,480	1,550	1,700	350	290
SK40SR	5,086	3,870	1,520	2,310 [2,310]	1,835	350	580	1,450	(2,570) 2,570		1,960	400	300
SK45SR	5,360	4,070	1,610	2,480 [2,430]	1,960	350	610	1,480	(2,600) 2,600		1,980	400	330

Model \ Code	N	O	P	Q	R	S	T	U	V	X	Y
SK15SR	910	1,300	615	(650) 675	115	(250) 275	55°	(70°) 85°	(1,420) 1,200	675	1,350
SK20SR	910	1,300	615	(650) 675	90	(225) 250	55°	(70°) 85°	(1,495) 1,250	700	1,400
SK25SR	910	1,500	645	(680) 705	70	(205) 230	55°	(70°) 85°	(1,755) 1,295	775	1,550
SK30SR	910	1,500	645	(680) 705	70	(205) 230	55°	(70°) 85°	(1,770) 1,350	775	1,550
SK35SR	910	1,500	645	(680) 705	45	(180) 205	55°	(78°) 85°	(1,940) 1,450	850	1,700
SK40SR	910	1,760	630	(790) 790	-50	(110) 110	55°	(80°) 85°	(1,710) 1,540	980	1,960
SK45SR	910	1,760	660	(830) 830	0	(165) 165	55°	(80°) 85°	1,580	990	1,980

The value in [] shows the iron shoe, and in () for the cab spec.

NOTES

2. MACHINE SPECIFICATIONS

Item		Model	SK15SR	SK20SR	SK25SR	
Performance	Standard bucket capacity	m ³	0.044	0.066	0.08	
	Travel speed	Rubber crawler	km/h	4.2/2.1	4.9/2.5	4.9/2.7
		Iron crawler	km/h	4.0/2.0	4.6/2.3	4.6/2.5
	Slewing speed	min ⁻¹ {rpm}	9.4 {9.4}	8.7 {8.7}	8.8 {8.8}	
	Gradeability	degree	30	←	←	
	Digging force	Bucket	kN {kgf}	13.1 {1,335}	17.5 {1,790}	20.8 {2,120}
Arm		kN {kgf}	9.8 {1,000}	12.8 {1,310}	15.6 {1,590}	
Arm length		(mm)	(920)	(1,015)	(1,130)	
Weight	Canopy Under carriage	Upper structure	kg	885	1,090	1,340
		Rubber crawler	kg	530	600	935
		Iron crawler	kg	590	650	975
		Rubber crawler	kg	1,580	1,900	2,550
		Iron crawler	kg	1,640	1,950	2,590
		Ground pressure	Rubber	kPa {kgf/cm ² }	25 {0.26}	26 {0.27}
	Iron		kPa {kgf/cm ² }	27 {0.27}	27 {0.28}	28 {0.28}
	Cab Under carriage	Upper structure	kg	985	1,190	1,470
		Rubber crawler	kg	530	600	935
		Iron crawler	kg	590	650	975
		Rubber crawler	kg	1,680	2,000	2,680
		Iron crawler	kg	1,740	2,050	2,720
Ground pressure		Rubber	kPa {kgf/cm ² }	27 {0.28}	28 {0.28}	28 {0.29}
	Iron	kPa {kgf/cm ² }	28 {0.29}	29 {0.29}	29 {0.30}	
Engine	Type		YANMAR 3TNA72		YANMAR 3TNE78A	
	Rated output	kW/min ⁻¹ {PS/rpm}	10.7/2,350 {14.5/2,350}		16.5/2,500 {22.5/2,500}	
	Max. torque	N·m/min ⁻¹ {kgf·m/rpm}	51/1,700 {5.2/1,700}		78.5/1,500 {8.0/1,500}	
	Displacement	ℓ {cc}	0.881 {879}		1.20 {1,204}	
	Number of cyl-Bore×Stroke	mm	3 - 72 × 72		3 - 78 × 78	
	Specific fuel consumption	g/kW·h {g/PS·h}	272 {200} or less		238 {175} or less	
	Capacity of fuel tank	ℓ	21		40	
Hydraulic system	Type of pump		3-section, gear	2-section variable displacement piston + 2gears		
	Set pres. of system	MPa {kgf/cm ² }	19.1 {195}	20.6 {210}	←	
	Slewing motor		Orbit motor		Axial piston	
	Travel motor		2-speed axial piston			
	Control valves		8-function c/v	9-function c/v		
	Capacity of hyd. oil tank(Full/Effective)	ℓ	38/30		51/36	



Suggest:

For more complete manuals. Please go to the home page.

<https://www.ebooklibonline.com>

If the above button click is invalid. Please download this document first, and then click the above link to download the complete manual.

Thank you so much for reading

**SK30SR SK40SR
SK35SR SK45SR**

Item		Model	SK30SR	SK35SR	SK40SR	SK45SR	
Performance	Standard bucket capacity	m ³	0.090	0.11	0.13	0.14	
	Travel speed	Rubber crawler	km/h	4.8/2.8	4.7/2.5	4.8/2.9	4.2/2.1
		Iron crawler	km/h	4.5/2.5	4.4/2.3	4.4/2.6	4.0/2.0
	Slewing speed	min ⁻¹ {rpm}	8.4 {8.4}	8.5 {8.5}	7.7 {7.7}	8.1 {8.1}	
	Gradeability	degree	30	←	←	←	
	Digging force	Bucket	kN{kgf}	24.3 {2,475}	26.9 {2,750}	32 {3,220}	35.5 {3,630}
		Arm	kN{kgf}	17.2 {1,760}	19.6 {2,000}	20.5 {2,080}	24.5 {2,500}
Arm length		(mm)	(1,180)	(1,280)	(1,350)	(1,430)	
Weight	Canopy Under carriage	Upper structure	kg	1,590	1,810	1,950	2,320
		Rubber crawler	kg	1,050	1,195	1,525	1,750
		Iron crawler	kg	1,090	1,285	1,585	1,790
		Rubber crawler	kg	2,970	3,400	3,970	4,660
		Iron crawler	kg	3,010	3,490	4,030	4,700
		Ground pressure	Rubber	kPa{kgf/cm ² }	29 {0.30}	26 {0.26}	25 {0.25}
	Iron		kPa{kgf/cm ² }	30 {0.31}	27 {0.27}	25 {0.25}	28 {0.28}
	Cab Under carriage	Upper structure	kg	1,090	1,285	1,585	1,790
		Rubber crawler	kg	3,100	3,530	4,100	4,790
		Iron crawler	kg	3,140	3,620	4,160	4,830
		Rubber crawler	kg	1,720	1,940	2,080	2,450
		Iron crawler	kg	1,050	1,195	1,525	1,750
		Ground pressure	Rubber	kPa{kgf/cm ² }	30 {0.31}	27 {0.27}	26 {0.26}
	Iron		kPa{kgf/cm ² }	32 {0.32}	28 {0.28}	26 {0.26}	29 {0.29}
Engine	Type		YANMAR 3TNE82A	YANMAR 3TNE84A	YANMAR 3TNE88A	YANMAR 4TNE88A	
	Rated output	kW/min ⁻¹ {PS/rpm}	16.9/2,300 {23.0/2,350}	19.3/2,350 {26.3/2,350}	22.5/2,400 {30.5/2,300}	27.2/2,200 {37/2,200}	
	Max. torque	N·m/min ⁻¹ {kgf·m/rpm}	79.4/1,600 {8.1/1,600}	98.0/1,500 {10.0/1,500}	103/1,600 {10.5/1,600}	132/1,600 {13.5/1,600}	
	Displacement	ℓ {cc}	1.330	1.496	1.642	2.189	
	Number of cyl—Bore×Stroke	mm	3—82×84	3—84×90	3—88×90	4—88×90	
	Specific fuel consumption	g/kW·h {g/PS·h}	238{175} or less		244{180} or less	238{175} or less	
	Capacity of fuel tank	ℓ	35		50		
Hydraulic system	Type of pump	2-section variable displacement piston + 2gears					
	Set pres. of system	MPa{kgf/cm ² }	20.6 {210}				
	Slewing motor		Orbit motor	Axial piston			
	Travel motor	2-speed axial piston					
	Control valves	9-function c/v					
	Capacity of hyd. oil tank(Full/Effective)	ℓ	51/36		81/60		

3. COMPONENTS SPECIFICATIONS

3-1 Engine specifications

Model	SK15SR	SK20SR
Applicable machine	PU06001~	PM02001~
Name	3TNA72-UYBB	3TNA72-UYB
Type	4-cycle vertical type, water cooled in-line 3-cylinders, Precombustion chamber type	
No. of cylinders – Bore × Stroke	mm	3 – 72 × 72
Total displacement	ℓ	0.879
Compression ratio		22.3 (Effective 20.5)
Compression pressure	MPa {kgf/cm ² }	2.94 ^{±0.1} {30 ^{±1} } at 275min ⁻¹ {rpm}
Rated output	kW/min ⁻¹ {PS/rpm}	10.7/2,350 {14.5/2,350}
Max. torque	N•m/min ⁻¹ {kgf•m/rpm}	51/1,700 {5.2/1,700}
Max. idling speed	min ⁻¹ {rpm}	2,550 ± 25
Min. idling speed	min ⁻¹ {rpm}	1,075 ± 25
Fuel consumption ratio	g/kW•h {PS•h}	272 {200} or less
Allowable inclination	Continuously 25 deg. (Fore and aft, Right and left), Instantly 30 deg. (Fore and aft, Right and left)	
Direction of rotation	Left (Seeing from flywheel side)	
Firing order	1-3-2-1	
Fuel injection timing (bTDC)	degree	14 ± 1
Fuel injection pressure	MPa {kgf/cm ² }	11.8 ^{+0.98} {120 ⁺¹⁰ }
Dimension of engine (Overall length × overall width × overall height)	mm	498 × 406 × 501
Dry weight	kg	100
Fuel injection pump	Bosch type	
Fuel filtration type	Filter paper type, full flow	
Lubricating oil pump	Trochoid pump	
Lubricating oil filtration type	Filter paper type	
Starter	V × kW	12 × 1.0
Alternator	V × A	12 × 20
Battery	V-A•h/hr	12-36/5
Starting aids	Glow plug	
Coolant capacity : Engine ℓ / Radiator ℓ		1.1/2.0
Lubricating oil : Full flow ℓ / Effective ℓ		2.4/1.0

<https://www.ebooklibonline.com>

Hello dear friend!

Thank you very much for reading.

Enter the link into your browser.

The full manual is available for immediate download.

<https://www.ebooklibonline.com>