

HYDRAULIC EXCAVATOR

**SHOP
MANUAL**

SK200(LC)-6E
SK210(LC)-6E(S)
model **SK210**NLC-6ES

INDEX

1	SPECIFICATION SECTION
2	MAINTENANCE SECTION
3	SYSTEM SECTION
4	DISASSEMBLY SECTION
5	TROUBLESHOOTING
6	ENGINE SECTION
7	INSTALLATION PROCEDURES FOR OPTIONAL ATTACHMENT

MAINTENANCE SPECIFICATION

MAINTENANCE

SYSTEM

DISASSEMBLING

TROUBLESHOOTING

E/G

OPT.

KOBELCO

Book code No. S5YN0017E

SK200(LC)-6E
 SK210(LC)-6E(S) Index of Shop Manual
 SK210NLC-6ES

Book Code No. Distribution Year—Month		Index No	Title	
S5YN0117E 2004-11			OUTLINE	YN01
S5YN0217E 2004-11			SPECIFICATION	YN02
S5YN0317E 2004-11			ATTACHMENT DIMENSION	YN03
S5YN1117E 2004-11			TOOLS	YN11
S5YN1217E 2004-11			STANDARD MAINTENANCE TIME SCHEDULE	YN12
S5YN1317E 2004-11			MAINTENANCE STANDARD AND TEST PROCEDURE	YN13
S5YN2117E 2004-11			MECHATRO CONTROL SYSTEM	YN21
S5YN2217E 2004-11			HYDRAULIC SYSTEM	YN22
S5YN2317E 2004-11			ELECTRICAL SYSTEM	YN23
S5YN2417E 2004-11			COMPONENTS SYSTEM	YN24
S5YN2517E 2004-11			AIR-CONDITIONER SYSTEM	YN25
—			—	
S5YN3117E 2004-11			DISASSEMBLING AND ASSEMBLING	YN31
S5YN3217E 2004-11			ATTACHMENT	YN32
S5YN3317E 2004-11			UPPER STRUCTURE	YN33
S5YN3417E 2004-11			TRAVEL SYSTEM	YN34
S5YN4117E 2004-11			MECHATRO CONTROL	YN41
S5YN4217E 2004-11			HYDRAULIC	YN42
S5YN4317E 2004-11			ELECTRICAL	YN43
S5YN4417E 2004-11			ENGINE	YN44
S5YN5117E 2004-11			ENGINE	YN51
S5YN6303E 2004-11			MOUNTING THE BREAKER AND NIBBLER & BREAKER	YN63
YN10-38001~ YQ10-05501~			APPLICABLE MACHINES	

KOBELCO

Book code No.

S5 YN01 17E

SHOP MANUAL **SK200**(LC)-6E
SK210(LC)-6E(S) **YN01**
SK210NLC-6ES

OUTLINE

TABLE OF CONTENTS

1. GENERAL PRECAUTIONS FOR MAKING REPAIRS 1
2. INTERNATIONAL UNIT CONVERSION SYSTEM 4

KOBELCO CONSTRUCTION MACHINERY CO., LTD.

<https://www.ebooklibonline.com>

Hello dear friend!

Thank you very much for reading.

Enter the link into your browser.

The full manual is available for immediate download.

<https://www.ebooklibonline.com>

Applicable Machines
YN10-38001~
YQ10-05501~

Revision	Date of Issue	Remarks
First edition	November, 2004	S5YN0117E K

1. GENERAL PRECAUTIONS FOR MAKING REPAIRS



1.1 PREPARATION BEFORE DISASSEMBLING

- (1) Knowledge of operating procedure
Read Operator's Manual carefully to understand the operating procedure.
- (2) Cleaning machines
Clean machines of soil, mud, and dust before carrying into the service shop.
Carrying a soiled machine into the service shop, causes making less efficient work and damage of parts.
- (3) Inspecting machines
Confirm the disassembling section before starting work, determine the disassembly procedure taking the conditions in work shop into account, and request to procure necessary parts in advance.
- (4) Recording
Record the following items to keep contact and prevent malfunction from recurring.
 - 1) Inspecting date, place
 - 2) Model name, Applicable machine No., Records on hour meter
 - 3) Trouble condition, place, cause
 - 4) Visible oil leakage, water leakage and damage
 - 5) Clogging of filters, etc., oil level, oil quality, oil contamination and looseness which can be inspected.
 - 6) Examine the problems on the basis of operation rate with the last inspection date and records on hour meter.
- (5) Arrangement and cleaning in service shop
 - 1) Tools required for repair work.
 - 2) Specify places to put the disassembled parts on in advance.
 - 3) Prepare oil pans for leaking oil, etc.



1.2 SAFETY WHEN DISASSEMBLING AND ASSEMBLING

- (1) Safety
 - 1) Wear appropriate clothing, safety shoes, safety helmet, goggles, and clothes with long sleeves.
 - 2) Suspend warning tag "Don't operate" from lever, and begin preliminaries before getting down to work.
 - 3) Before starting inspection and maintenance which contain the danger of being caught in machine, stop the engine.

- 4) Confirm the position of first-aid kit and fire extinguisher, and also where to make contact for emergency measure and ambulance to prepare for accidents and fire.
- 5) Choose a hard, flat and safe place, and put attachment on the ground without fail.
- 6) Use crane, etc. to remove parts of heavy weight (23kg [50 lb] or more).
- 7) Use proper tools, and change or repair defective tools.
- 8) Machine and attachment required to work in the lifting condition should be supported with supports or blocks securely.

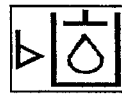

1.3 DISASSEMBLING AND ASSEMBLING HYDRAULIC EQUIPMENT

- (1) Removing hydraulic equipment assy
 - 1) Before removing pipes, release the pressure of hydraulic oil tank, or open the cover on the return side to tank, and take out the filter.
 - 2) Put the oil in the removed pipes in reservoir taking care it is not spilled on the ground.
 - 3) Pipes with plugs or caps to prevent oil leaking, entry of dust, etc.
 - 4) Clean the outside surface of equipment, etc. before disassembling, and drain hydraulic oil and gear oil before putting them on working bench.
- (2) Disassembling hydraulic equipment
 - 1) Since performance and function of hydraulic equipment after disassembly and assembly results in immunity from responsibility on the manufacture's side, disassembly, assembly and conversion without permission are strictly prohibited.
 - 2) If it is unavoidably necessary to disassemble and convert, it should be carried out by experts or personnel authorized through service training.
 - 3) Make match mark on parts for reassembling.
 - 4) Before disassembling, read Disassembling Instruction in advance, and determine if the disassembly and assembly are permitted or not.
 - 5) For parts which are required to use jig and tools, don't fail to use the specified jig and tools.
 - 6) For parts which can not be removed in the specified procedure, never force removal. First check for the cause.

- 7) The removed parts should be put in order and tagged so as to install on proper places without confusion.
- 8) For common parts, pay attention to the quantity and places.
- (3) Inspecting parts
 - 1) Check that the disassembled parts are free from adherence, interference and non-uniform working face.
 - 2) Measure the wear of parts and clearance, and record the measured values.
 - 3) If an abnormality is detected, repair or replace the parts.
- (4) Reassembling hydraulic equipment
 - 1) Before cleaning, turn the fan on or open doors to ventilate air.
 - 2) Before assembly, clean parts roughly first, and then completely.
 - 3) Remove with oil by compressed air, and apply hydraulic oil or gear oil, and then assemble them.
 - 4) Replace the removed O ring, back-up rings and oil seal with new ones, and apply grease oil on them before assembling.
 - 5) Removes stain and water on the surface on which liquid sealant are applied, decrease them, and apply liquid sealant on them.
 - 6) Before assembling, remove rust preventives on new parts.
 - 7) Use special tools to fit bearings, bushing and oil seal.
 - 8) Assemble parts matching to the marks.
 - 9) After completion, check that there is no omission of parts.
- (5) Installing hydraulic equipment
 - 1) Confirm hydraulic oil and lubrication oil.
 - 2) Air release is required in the following cases ;
 - a. Change of hydraulic oil
 - b. Replacement of parts on suction pipe side
 - c. Removing and attaching hydraulic pump
 - d. Removing and attaching swing motor
 - e. Removing and attaching travel motor
 - f. Removing and attaching hydraulic cylinder

⚠ If hydraulic oil and lubricating oil are not filled and also air bleed is not performed, the hydraulic equipment may be damaged.

- 3) For air bleed of hydraulic pump and swing motor, loosen drain plug on the upper part, start engine, and run in low idling, then bleed air until hydraulic oil is oozed out. After completion of air bleed, tighten plug securely.
- 4) For air bleed of travel motor and hydraulic cylinder, starts engine and operate it for 10 minutes or more at no-load and low speed.

⚠ For cylinder, don't move it to the stroke end at beginning.

- 5) Air in pilot circuit can be bled out by only operating digging, swing and traveling motions thoroughly.
- 6) Check hydraulic oil level.
Move attachments to hydraulic oil check position, and check hydraulic oil level of tank. Refill oil if the oil level is lower than the minimum level.

How to check oil level of hydraulic oil tank

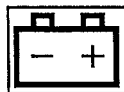
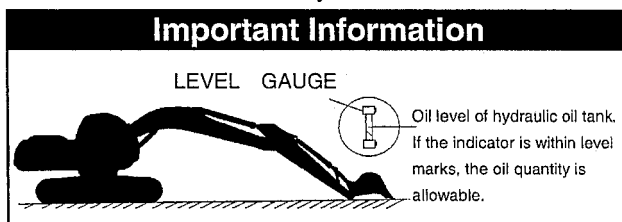

1.4 ELECTRICAL EQUIPMENT

- (1) The disassembly of electrical equipment is not allowed.
- (2) Handle equipment with care so as not to drop it or bump it.
- (3) Connector should be removed by unlocking while holding the connector.
Never stress in tension to the caulked section by pulling wire.
- (4) Check that connector is connected and locked completely.
- (5) Starter key off before removing and connecting connector
- (6) Starter key off before touching terminals of starter and alternator.
- (7) Remove battery grounding terminal before beginning work close to battery and battery relay with tools.
- (8) Wash machine with care so as not to splash water on electrical equipment and connector.

- (9) When water has entered in the waterproofed connector, the removing of water is not easy. So check the removed waterproofed connector with care to protect it from entry of water. If moisture adheres on it, dry it completely before connecting.



Battery electrolyte is dangerous.

The battery electrolyte is dilute sulfuric acid, and causes scald and loss of eyesight by adhering on eyes, skin and clothes. When the electrolyte has adhered on them, take an emergency measure immediately and see a doctor for medical advice.

- When it has adhered on skin ;
Wash with soap and water.
- When it has got in eyes ;
Wash in water for 10 minutes or more immediately.
- When it has spilled out in large quantity ;
Use sodium bicarbonate to neutralize, or wash away with water.
- When it was swallowed ;
Drink milk or water.
- When it has adhered on clothes ;
Wash it immediately.

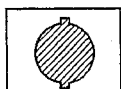

1.5 HYDRAULIC PARTS

1) O ring

- Check that O ring is free from flaw and has elasticity before fitting.
- Even if the size of O ring is equal, the usage differs, for example in dynamic and static sections, the rubber hardness also differs according to the pressure force, and also the quality differs depending on the materials to be seated. So, choose proper O ring.
- Fit O ring so as to be free from distortion and bend.
- Floating seal should be put in pairs.

2) Flexible hose (F hose)

- Even if the connector and length of hose are the same, the parts differ according to the withstanding pressure. Use proper parts.

- Tighten it to the specified torque, and check that it is free from distortion, over tension, interference, and oil leakage.

1.6 WELD REPAIR

- (1) The weld repair should be carried out by authorized personnel in the specified procedure after disconnecting the grounding cable of battery. If the grounding cable is not disconnected, the electrical equipment may be damaged.
- (2) Remove parts which may cause flame due to the entry of spark beforehand.
- (3) Repair attachments which are damaged, giving particular attention to the plated section of piston rod to protect it from sparks, and don't fail to cover the section with fire proof clothes.

1.7 ENVIRONMENTAL ISSUES

- (1) Engine should be started and operated in the place where air can be sufficiently ventilated.
- (2) Waste disposal
The following parts follows the regulation.
Waste oil, waste container and battery
- (3) Precautions for handling hydraulic oil
Hydraulic oil may cause inflammation of eyes. Wear goggles to protect eyes on handling it.
 - When it has got in eyes ;
Wash eyes with water until the stimulus is gone.
 - When it was swallowed ;
Don't force him to vomit it, but immediately receive medical treatment.
 - When it has adhered on skin ;
Wash with soap and water.
- (4) Others
For spare parts, grease and oil, use KOBELCO genuine ones.

2. INTERNATIONAL UNIT CONVERSION SYSTEM

Introduction

Although this manual uses the JIS unit system. If you need SI unit, refer to following international system of units.

Given hereinunder are an excerpt of the units that are related to this manual :

1. Etymology of SI Units

French : Le Système International d' Unités

English: International System of Units

2. Construction of SI Unit System

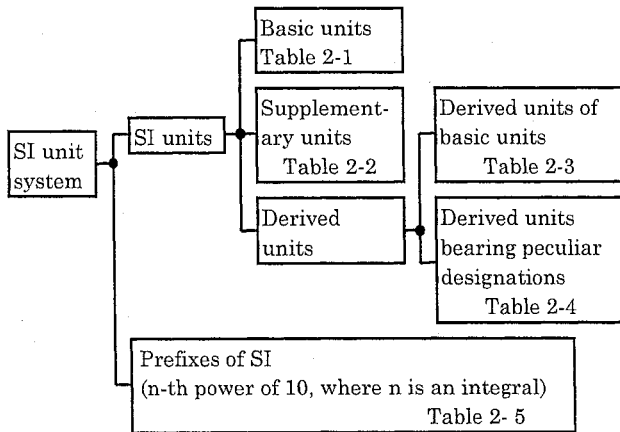

(1) Basic Units

Table 2-1

QUANTITIES	DESIGNATION	SIGN
Length	Meter	m
Mass	Kilogram	kg
Time	Second	s
Current	Ampere	A
Thermodynamic temperature	Kelvin	K
Gram molecule	Mol	mol
Luminous intensity	Candela	cd

(2) Supplementary Units

Table 2-2

QUANTITIES	DESIGNATION	SIGN
Plane angle	Radian	rad
Solid angle	Steradian	sr

(3) Derived Units of Basic Units

Table 2-3

QUANTITIES	DESIGNATION	SIGN
Area	Square meter	m ²
Volume	Cubic meter	m ³
Velocity	Meter per second	m/s
Acceleration	Meter per second / second	m/s ²
Density	Kilogram per cubic meter	kg/m ³

(4) Derived Units bearing Peculiar Designations

Table 2-4

QUANTITIES	DESIGNATION	SIGN	DERIVED UNIT
Frequency	Hertz	Hz	1Hz=1s ⁻¹
Force	Newton	N	1N=1kgf·m/s ²
Pressure, Stress	Pascal	Pa	1Pa=1N/m ²
Energy Work, Quantity of heat	Joule	J	1J=1N·m
Power Motive power, Electric power	Watt	W	1W=1J/s
Charge, Quantity of electricity	Coulomb	C	1C=1A·s
Potential Voltage, Electromotive force	Volt	V	1V=1J/C (1W/A)
Quantity of static electricity Capacitance	Farad	F	1F=1C/V
Electric resistance	Ohm	Ω	1Ω=1V/A
Celsius temperature	Celsius degree or degree	°C	t°C=(t+273.15)K
Illuminance	lux	lx	1 lx=1 lm/m ²

(5) Prefixes of SI

Table 2-5

PREFIX		POWER
DESIGNATION	SIGN	
Giga-	G	10 ⁹
Mega-	M	10 ⁶
Kilo-	k	10 ³
Hecto-	h	10 ²
Deca-	da	10
Deci-	d	10 ⁻¹
Centi-	c	10 ⁻²
Milli-	m	10 ⁻³
Micro-	μ	10 ⁻⁶
Nano-	n	10 ⁻⁹
Pico-	p	10 ⁻¹²

(6) Unit Conversion Table

Table 2-6

QUANTITIES	JIS	SI	REMARKS
Mass	kgf	kg	
Force	kgf	N	1kgf=9.807N
Torque	kgf·m	N·m	1kgf·m=9.807N·m
Pressure	kgf/cm ²	MPa	1kgf/cm ² =0.098MPa
Motive power	PS	kW	1PS=0.7355kW
Revolution	rpm	min ⁻¹	r/min ※1

KOBELCO

Book code No.

S5 YN02_{17E}

SHOP MANUAL

SK200(LC)-6E

SK210(LC)-6E(S)

SK210NLC-6ES

YN02

SPECIFICATION

TABLE OF CONTENTS

1. NAME OF COMPONENTS	1
2. GENERAL DIMENSIONS	2
3. WEIGHT OF COMPONENTS	4
4. TRANSPORTATION	5
5. SPECIFICATIONS AND PERFORMANCE	8
6. TYPE OF CRAWLER	9
7. TYPE OF BUCKET	10
8. COMBINATIONS OF ATTACHMENT	11
9. ENGINE SPECIFICATIONS	12

KOBELCO CONSTRUCTION MACHINERY CO., LTD.

Applicable Machines
YN10-38001~
YQ10-05501~

Revision	Date of Issue	Remarks
First edition	November, 2004	S5YN0217E K

1. NAME OF COMPONENTS

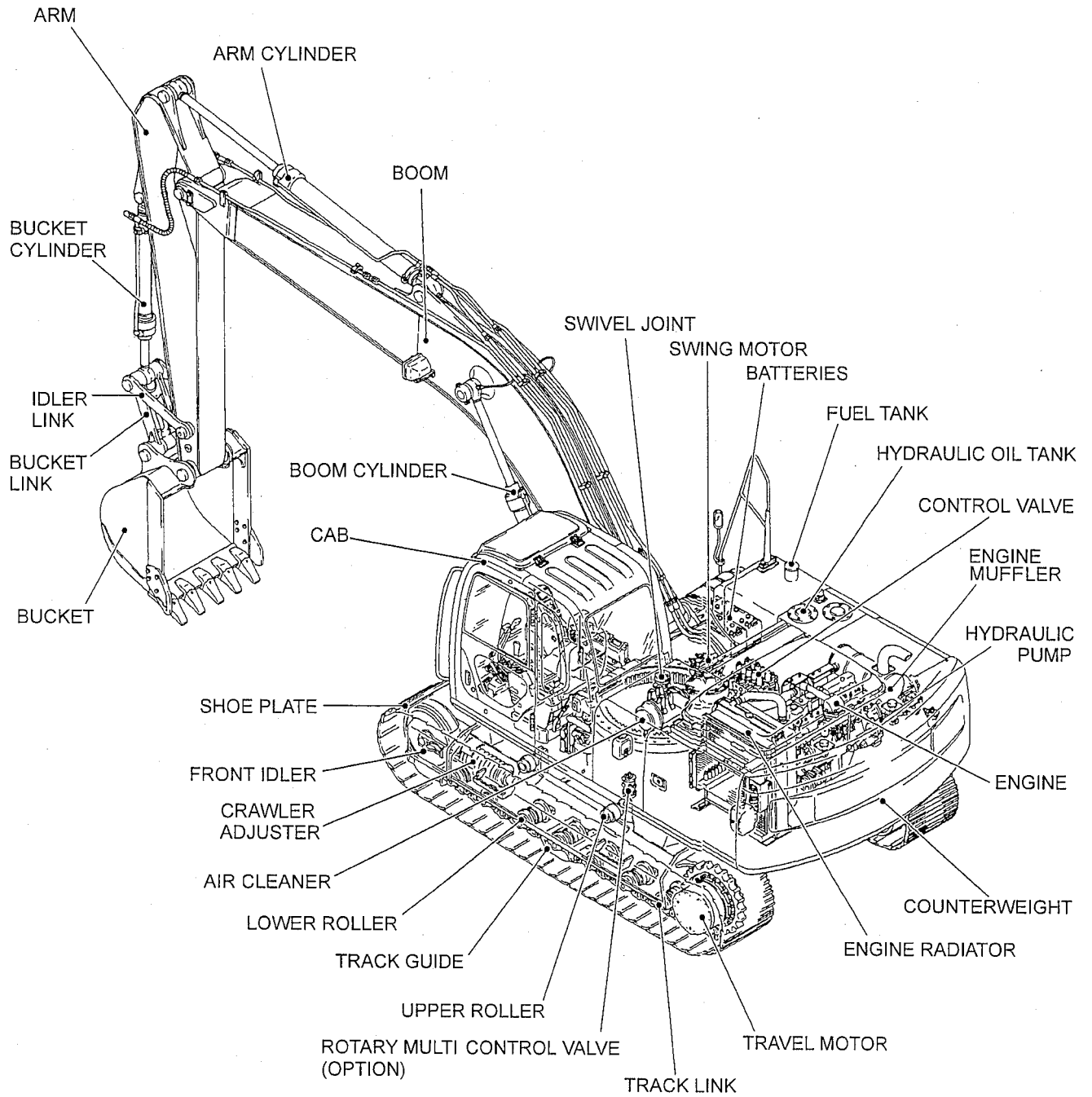

2. GENERAL DIMENSIONS

Unit : mm (ft-in)

2.1 5.65m (18' 6") Boom+2.94m (9' 8") Standard Arm+0.80m³ (1.05cu-yd) Bucket+600mm (23.6") Shoe

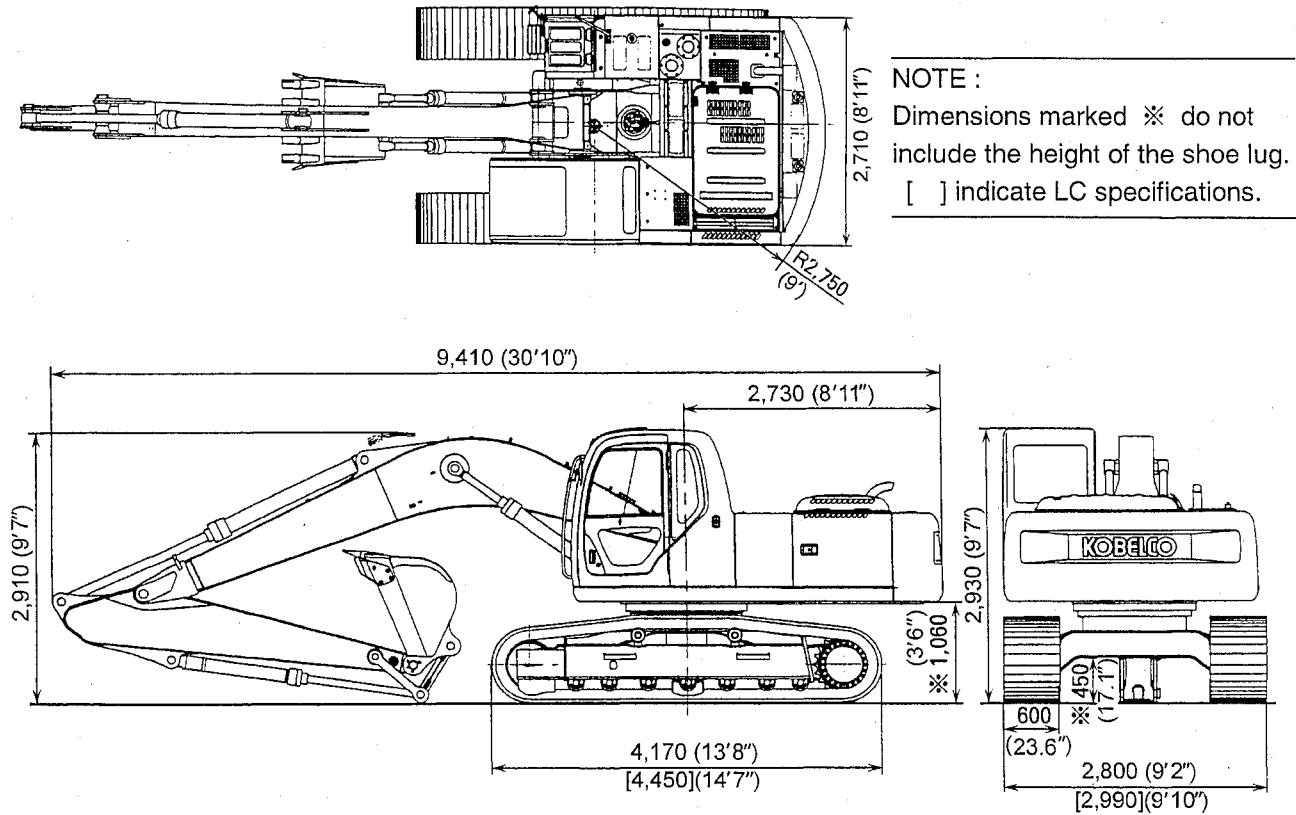

2.2 5.65m (18' 6") Boom+2.4m (7' 10") Short Arm+0.93m³ (1.22cu-yd) Bucket+600mm (23.6") Shoe

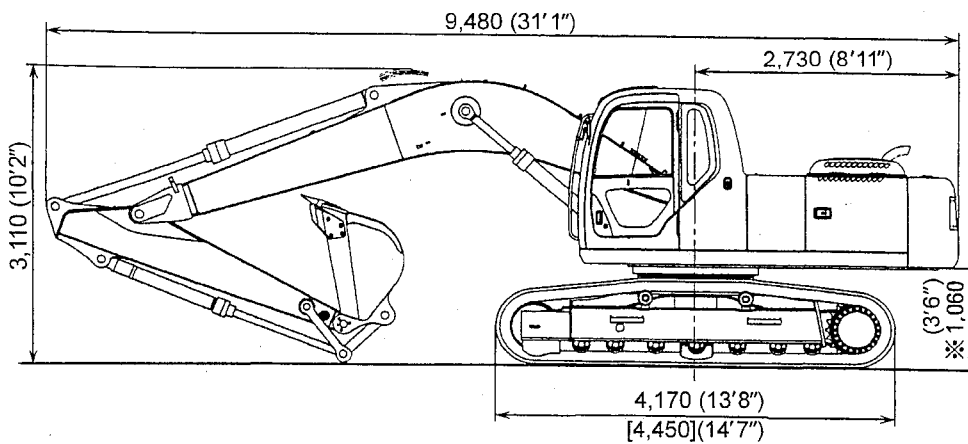

Unit : mm (ft-in)

2.3 5.65m (18' 6") Boom+3.5m (11' 6") Long Arm+0.70m³ (0.92cu.yd) Bucket

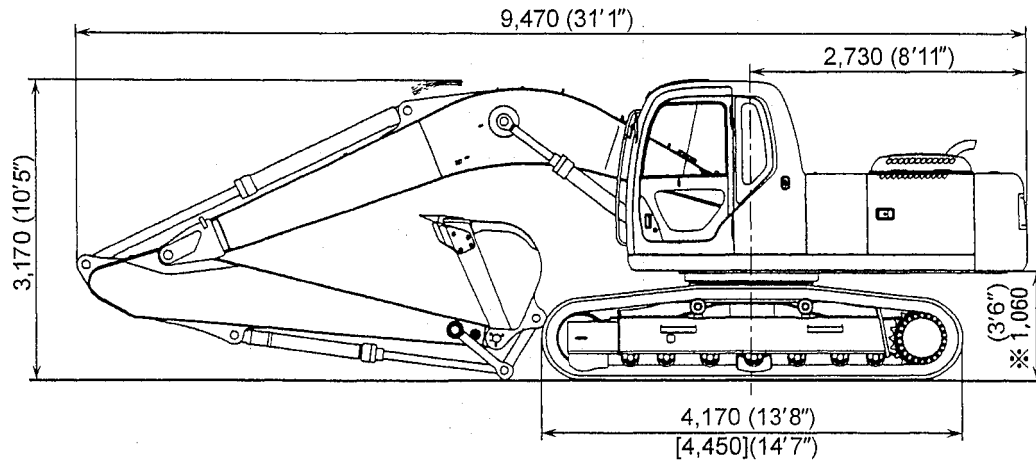

2.4 SK210NLC-6ES ; 5.65m (18' 6") Boom+2.94m (9' 8") Arm

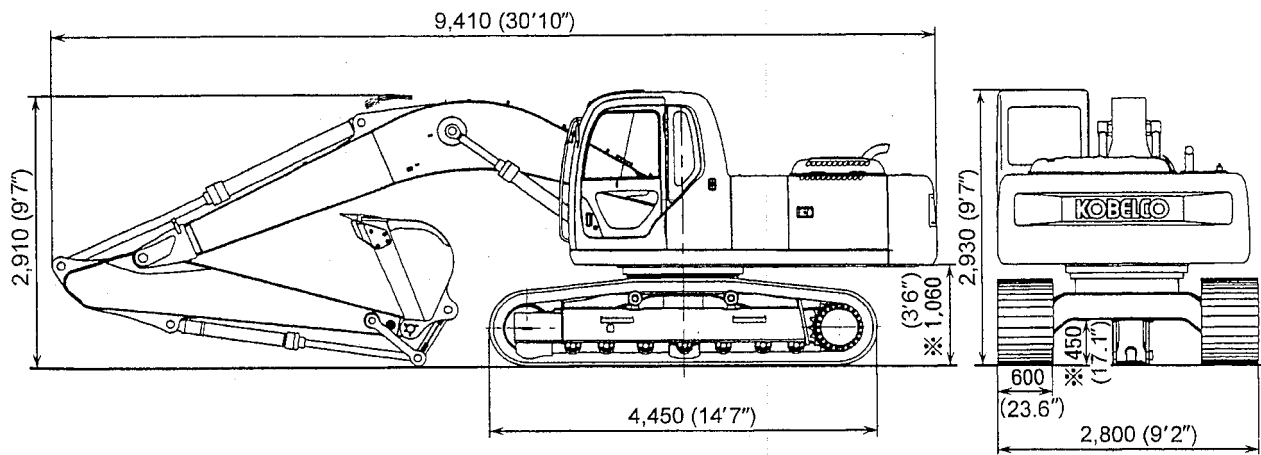

3. WEIGHT OF COMPONENTS

Unit : kg (lbs)

Item	Model	SK200-6E	SK210LC-6E(S)	SK210NLC-6ES
Machine complete		20,000 (44,100)	20,400 (45,000)	20,300 (44,800)
1. Upper frame assy (including the following :)		9,900 (21,800)	←	←
1.1 Upper frame		1,700 (3,750)	←	←
1.2 Counterweight		4,620 (10,200)	←	←
1.3 Cab		260 (570)	←	←
1.4 Engine		※ 480 (1,060)	←	←
1.5 Hydraulic oil tank		※ 156 (344)	←	←
1.6 Fuel tank		※ 93 (205)	←	←
1.7 Slewing motor (including reduction unit)		235 (520)	←	←
1.8 Control valve		165 (364)	←	←
1.9 Boom cylinder		※ 177 (390)×2	←	←
1.10 Pin (for mounting boom)		45 (99)	←	←
1.11 Pump		127 (280)	←	←
1.12 Radiator		70 (154)	←	←
2. Lower frame assy (including the following :)		6,800 (15,000)	7,200 (15,900)	7,120 (15,700)
2.1 Lower frame		2,260 (4,980)	2,410 (5,310)	2,360 (5,200)
2.2 Slewing bearing		245 (540)	←	←
2.3 Travel motor (including reduction unit)		250 (550)×2	←	←
2.4 Upper roller		22 (49)×4	←	←
2.5 Lower roller		35 (77)×14	35 (77)×16	←
2.6 Front idler		106 (234)×2	←	←
2.7 Idler adjuster		104 (230)×2	←	←
2.8 Sprocket		54 (119)×2	←	←
2.9 Swivel joint		30 (66)	←	←
2.10 Track link with 600mm (23.6in) shoes assy		1,260 (2,780)×2	1,350 (2,980)×2	←
Track link with 700mm (27.6in) shoes assy		1,470 (3,240)×2	1,660 (3,660)×2	←
Track link with 800mm (31.5in) shoes assy		1,600 (3,530)×2	1,700 (3,750)×2	←
Track link with 600mm (23.6in) with flat shoes assy		1,510 (3,330)×2	1,600 (3,530)×2	←
2.10.1 Track link assy		510 (1,120)×2	540 (1,190)×2	←
3. Attachment (including the following / STD :)		3,300 (7,280)	←	←
[5.65m (18ft-6in) Boom+2.94m (9ft-8in) Arm +0.80m ³ (1cu-yd) Bucket]				
3.1 Bucket assy (STD)		650 (1,470)	←	←
3.2 STD Arm assy (including the following :)		990 (2,180)	←	←
3.2.1 STD Arm		610 (1,345)	←	←
3.2.2 Bucket cylinder		※ 148 (326)	←	←
3.2.3 Idler link		21 (46)×2	←	←
3.2.4 Bucket link		90 (198)	←	←
3.2.5 Pin (2pcs. for mounting bucket cylinder / 2pcs. for mounting bucket)		97 (214)	←	←
3.3 Boom assy		1,620 (3,570)	←	←
3.3.1 Boom		1,330 (2,930)	←	←
3.3.2 Arm cylinder		※ 250 (550)	←	←
3.3.3 Pin (Mounting arm • Mounting arm cylinder)		40 (88)	←	←
4. Lubricant and water (including the following :)		535 (1,180)	←	←
4.1 Hydraulic oil		215 (470)	←	←
4.2 Engine oil		20 (44)	←	←
4.3 Fuel		280 (617)	←	←
4.4 Water		20 (44)	←	←

NOTE : Numerical values marked ※ indicate the dry weight.

4. TRANSPORTATION

4.1 OVERALL DIMENSIONS OF MACHINE ON A TRAILER

(1) 5.65m (18ft-6in) Boom+2.94m (9ft-8in) Arm+0.80m³ (1.05cu-yd) Bucket

Item	Model	SK200-6E	SK200LC-6E
Width 600mm (23.6in) shoes mm(ft-in)		2,800 (9' 2")	2,990 (9' 6")
Weight	kg(lbs)	20,000 (44,100)	20,400 (45,000)

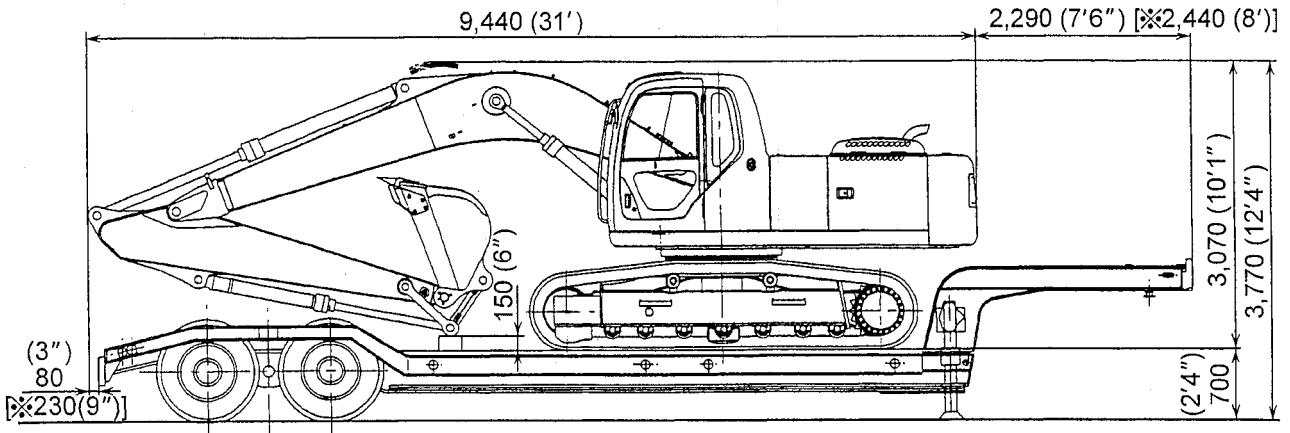

NOTE : ※ marks indicate LC specifications.

Unit : mm (ft-in)

(2) 5.65m (18ft-6in) Boom+3.5m (11ft-6in) Long Arm+0.70m³ (0.92cu-yd) Bucket

Item	Model	SK200-6E	SK200LC-6E
Width 600mm (24in) shoes mm(ft-in)		2,800 (9' 2")	2,990 (9' 6")
Weight (Inc. bucket weight)	kg(lbs)	20,100 (44,300)	20,500 (45,200)

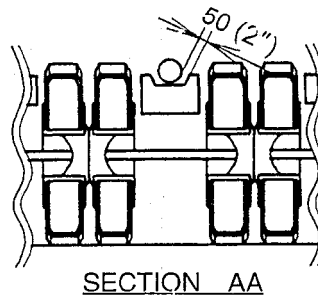
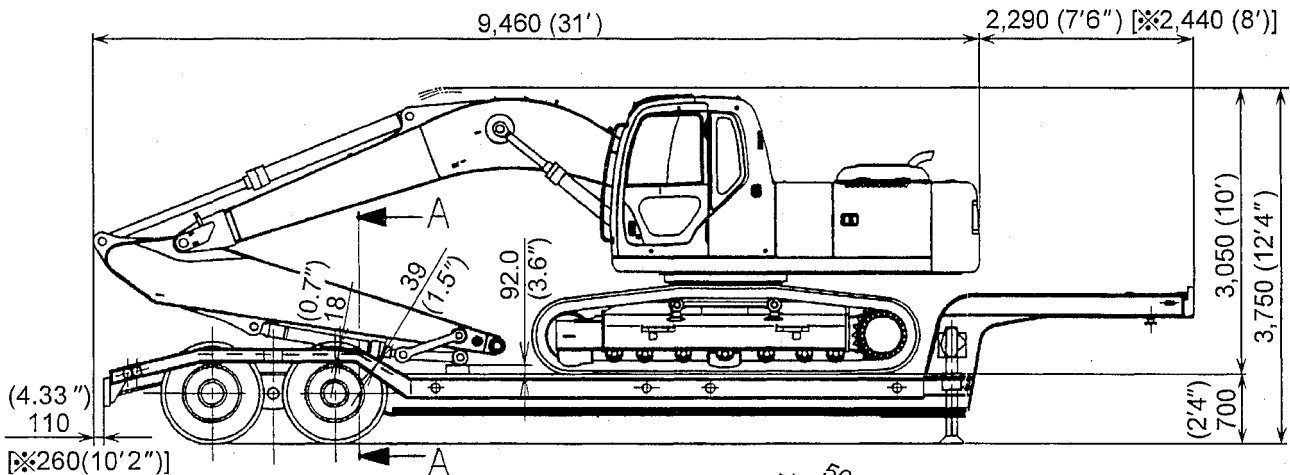

SECTION AA

NOTE : ※ marks indicate LC specifications.

Unit : mm(ft-in)

4.2 DIMENSIONS OF ATTACHMENT

(1) BOOM

Item	Type	5.65m (18ft-6in) Boom	5.65m (18ft-6in) Boom (HD)
Length×Height×Width L×H×W	m(ft-in)	5.85×1.57×0.77 (19' 2"×5' 2"×2' 6")	5.85×1.57×0.77 (19' 2"×5' 2"×2' 6")
Weight	kg (lbs)	1,620 (3,570)	1,740 (3,840)

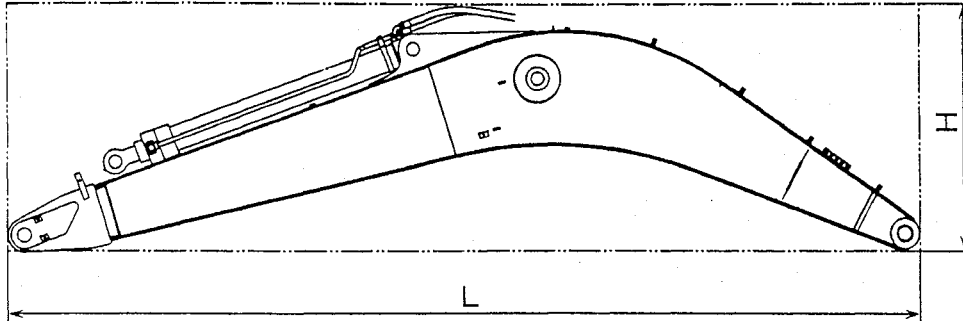

(2) ARM AND BUCKET

Item	Type	2.4m (7ft-10in) Arm +0.93m ³ (1.22cu.yd) Bucket	2.94m (9ft-8in) Arm +0.80m ³ (1.05cu.yd) Bucket	3.5m (11ft-6in) Arm +0.70 m ³ (0.92cu.yd) Bucket
Length×Height×Width L×H×W	m(ft-in)	4.72×0.895×1.35 (15' 6"×2' 11"×4' 5")	5.25×0.895×1.16 (17' 3"×2' 11"×4')	5.80×0.895×1.08 (19' ×2' 11"×3' 7")
Weight	kg (lbs)	1,570 (3,460)	1,650 (3,640)	1,760 (3,880)

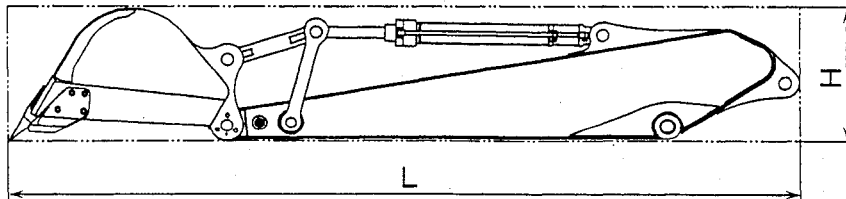

(3) ARM AND BUCKET (HD Spec.)

Item	Type	2.94m (9ft-8in) Arm+0. 80m ³ (1.05cu.yd) Bucket
Length×Height×Width L×H×W	m(ft-in)	5.25×0.90×1.18 (17' 3"×2' 11"×3' 10")
Weight	kg (lbs)	1,780 (3,920)

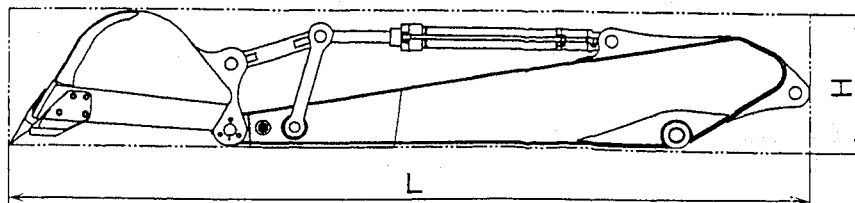

(4) ARM

Item	Type	2.4m (7ft-10in) Arm	2.94m (9ft-8in) Arm	3.5m (11ft-6in) Arm
Length×Height×Width L×H×W	m(ft-in)	3.36×0.80×0.54 (11' 0"×2' 7"×1' 9")	3.90×0.80×0.54 (12' 10"×2' 7"×1' 9")	4.5×0.80×0.54 (14' 9"×2' 7"×1' 9")
Weight	kg (lbs)	910 (2,010)	990 (2,180)	1,120 (2,470)

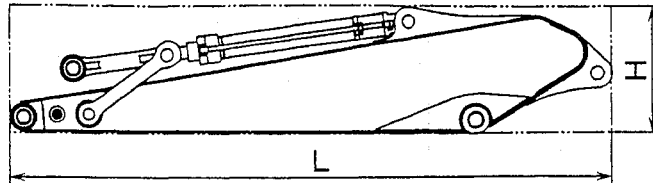

(5) ARM (HD Spec.)

Item	Type	2.94m (9ft-8in) Arm
Length×Height×Width L×H×W	m(ft-in)	3.90×0.80×0.54 (12' 10"×2' 7"×1' 9")
Weight	kg (lbs)	1,080 (2,380)

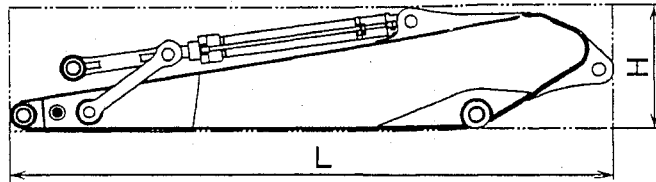

(6) BUCKET

Type	Hoe bucket			
Length×Height×Width L×H×W m (ft-in)	1.37×1.26×0.87 (4' 6"×4' 2"×2' 10")	1.37×1.26×1.07 (4' 6"×4' 2"×3' 6")	1.37×1.26×1.16 (4' 6"×4' 2"×3' 10")	1.37×1.26×1.33 (4' 6"×4' 2"×4' 4")
Weight kg (lbs)	520 (1,150)	630 (1,390)	650 (1,430)	710 (1,560)
Bucket capacity m ³ (cu·yd)	0.51 (0.67)	0.70 (0.92)	STD 0.80 (1.05)	0.93 (1.22)

Type	Hoe bucket	Slope finishing bucket		
Length×Height×Width L×H×W m (ft-in)	1.37×1.26×1.16 (4' 6"×4' 2"×3' 10")	1.25×0.90×2.20 (4' 1"×2' 11"×7' 3")		
Weight kg (lbs)	750 (1,650)	890 (1,960)		
Bucket capacity m ³ (cu·yd)	0.80 (1.05) HD	0.82 (1.07)		

● Hoe bucket

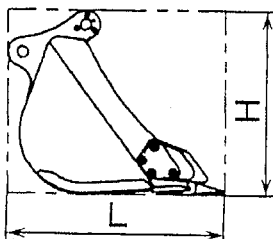

● Slope finishing bucket

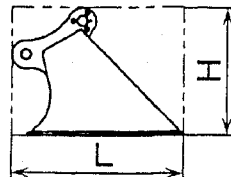

5. SPECIFICATIONS AND PERFORMANCE

5.1 SPEED AND CLIMBING CAPABILITY

Item	Area & Model	KCME	ASIA, OCEANIA
		SK210(LC)-6ES, SK210NLC-6ES	SK200(LC)-6E
Swing speed	min ⁻¹ {rpm}	11.0 {11.0}	←
Travel speed (1-speed/2-speed)	km/h (mile/h)	4.0 / 6.0 (2.4 / 3.7)	←
Gradeability	%(degree)	70 (35)	←

5.2 ENGINE

Engine model	MMC (Mitsubishi) 6D34—TLU2D	MMC 6D34—TLE2A
Type	Water-cooled, 4-cycle direct injection type engine with inter cooler turbo charger	←
Number of cylinders—Bore×Stroke	6—104mm×115mm (4.09in×4.53in)	←
Total displacement	5,861cc (357.64cu·in)	←
Rated output / Rotation speed	110kW (150PS) / 2,000min ⁻¹	←
Maximum torque / Rotation speed	59kgf·m (428 lbf·ft) / 1,500min ⁻¹	←
Starter	24V / 5.0kW	←
Alternator	24V / 35A	←

5.3 HYDRAULIC COMPONENTS

Hydraulic pump	Variable displacement axial piston + gear pump	←
Hydraulic motor (swing)	Axial piston motor	←
Hydraulic motor (travel)	2-speed axial piston motor	←
Control valve	6-spool control valve	←
Cylinder (Boom, Arm, Bucket)	Double action cylinder	←
Oil cooler	Air-cooled type	←

5.4 WEIGHT

Unit : kg (lbs)

	SK200-6E	SK210LC-6E(S)	SK210NLC-6ES
Fully equipped weight	20,000 (44,100)	20,400 (45,000)	20,300 (44,800)
Upper structure	9,900 (21,800)	←	←
Lower machinery	6,800 (15,000)	7,200 (15,900)	7,120 (15,700)
Attachment (5.65m (18 ft-6in) Boom+2.94m (9ft-8in) Arm +0.80m ³ (1.05cu·yd) Bucket)	3,300 (7,280)	←	←

6. TYPE OF CRAWLER

6.1 TYPE OF SHOE

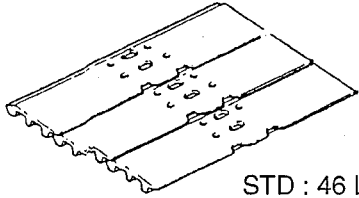
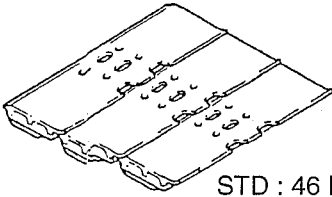
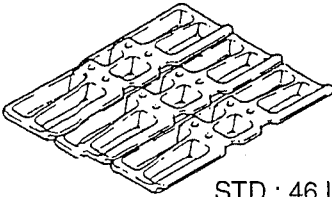
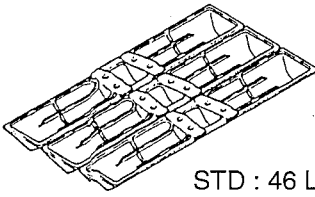
Shape	Shoe width mm (in)		Overall width of crawler mm (ft-in)	Ground pressure kgf /cm ² (psi)
Grouser shoe  STD : 46 LINKS LC : 49 LINKS	STD	600 (23.6)	2,800 (9'2")	0.46 (6.53)
	LC		2,990 (9'10")	0.43 (6.10)
	STD	700 (27.6)	2,900 (9'6")	0.40 (5.66)
	LC		3,090 (10'2")	0.38 (5.37)
	STD	800 (31.5)	3,000 (9'10")	0.35 (4.98)
	LC		3,190 (10'6")	0.33 (4.69)
Rubber pad shoe  STD : 46 LINKS LC : 49 LINKS	STD	600 (23.6)	2,800 (9'2")	0.47 (6.68)
	LC		2,990 (9'10")	0.44 (6.26)
Flat shoe  STD : 46 LINKS LC : 49 LINKS	STD	600 (23.6)	2,800 (9'2")	0.47 (6.68)
	LC		2,990 (9'10")	0.44 (6.26)
Triangle shoe  STD : 46 LINKS LC : 49 LINKS	STD	900 (35.4)	3,100 (10'2")	0.32 (4.55)
	LC		3,290 (10'10")	0.30 (4.27)

NOTE :

Use grouser shoes on rough ground (areas covered with rocks and gravel). If you drive or excavate with other shoes, this may cause shoe bending, shoe bolt looseness, and track assembly (link, roller, etc.) damage.

7. TYPE OF BUCKET

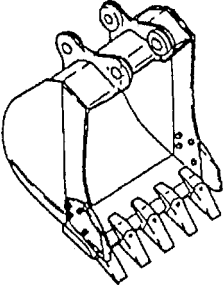
Hoe bucket	Heaped capacity m ³ (cu·yd)	Struck m ³ (cu·yd)	Outer width mm (ft-in)		Number of tooth	W or W/O side cutter	Availability of face shovel	Weight kg (lbs)
			With side cutter	Without side cutter				
	0.51(0.67)	0.39 (0.51)	870 (2'10")	770 (2'6")	3	W	YES	520 (1,150)
	0.70(0.92)	0.52 (0.68)	1,080 (3'6")	980 (3'3")	5	W	YES	630 (1,390)
	STD 0.80(1.05)	0.59 (0.77)	1,160 (3'10")	1,060 (3'6")	5	W	YES	650 (1,430)
	Heavy Digging 0.80(1.05)	0.59 (0.77)	1,150 (3'9")	1,060 (3'6")	4	W	YES	750 (1,650)
	0.93(1.2)	0.67 (0.88)	1,330 (4'4")	1,230 (4')	5	W	YES	710 (1,560)

8. COMBINATIONS OF ATTACHMENT

Type	Bucket		Available Arm		
	Heaped capacity m ³ (cu·yd)	Struck m ³ (cu·yd)	2.94m (9ft-8in) Arm (STD)	3.5m (11ft-6in) Arm (Long)	2.4m (7ft-10in) Arm + Arm (Short)
Hoe bucket	0.51 (0.67)	0.39 (0.51)	○	○	○
	0.70 (0.92)	0.52 (0.68)	○	◎	○
	STD 0.80 (1.05)	0.59 (0.77)	◎	△	○
	Heavy digging 0.80 (1.05)	0.59 (0.77)	○	×	○
	0.93 (1.2)	0.67 (0.88)	△	×	◎
Breaker	—	—	○ (Reinforced arm)	○ (Reinforced arm)	○ (Reinforced arm)
Nibbler	—	—	○ (Reinforced arm)	×	○ (Reinforced arm)

NOTE :

- ◎ Standard combination
- General operation : Excavation or loading of sand, gravel, and clay
- △ Light operation : Mainly loading or loose gravel (e.g., cultivation or loading of sand or gravel)
- × Prohibited combination : There are problems from the view points of strength and stability.

- ⚠ ● Use the attachments recommended by KOBELCO. Reinforcement of arm allows to use it as nibbler and breaker.
The trouble due to the use in the condition "Use not allowed" described in the above table is not included in our responsibility

⚠ CAUTION

If any other bucket, except for the backhoe bucket, is turned over and used for excavation, damage to the arm and bucket may occur.

9. ENGINE SPECIFICATIONS

9.1 SPECIFICATIONS

Applicable machine		SK200(LC)-6E, SK210(LC)-6E(S), SK210NLC-6ES		
Engine model		MITSUBISHI 6D34-TLE2A, 6D34-TLU2D		
Type		Diesel, 4-cycle water-cooled, in-line, direct injection, with inter cooler turbo charger		
Number of cylinder× Bore×Stroke	mm (in)	6×104×115 (4.09×4.53)		
Total displacement	cc (cu·in)	5,861 (358)		
Compression ratio		18.2		
Rated output	PS (kW) at min ⁻¹	150 (110) at 2,000		
Maximum torque	kgf·m (lbf·ft) at min ⁻¹	59 (428) at 1,500		
High idling	min ⁻¹	2,220		
Low idling	min ⁻¹	1,000±25		
Injection valve opening pressure	kgf/cm ² (psi)	220 (3,130)		
Thermostat action Start/Full open	°C (°F)	76.5 / 90 (170 / 194)		
Firing order		1-5-3-6-2-4		
Compression pressure	kgf/cm ² (psi)	26.5 (377)		
Lubrication oil pressure	kgf/cm ² (psi) at min ⁻¹	1.5~5 (21~71) at 850		
Fuel injection timing		14° before top dead point		
Valve clearance		Valve clearance	Open	Close
	Intake valve	0.4mm (0.016") at cool	19° before top dead point	53° after bottom dead point
	Exhaust valve	0.4mm (0.016") at cool	60° before bottom dead point	16° after top dead point
Starter capacity	V×kW	24×5.0		
Generator capacity (Alternator)	V×A	24×35		
Cooling fan drive method		Ø600 (23.6") suction type 6 fans, V-belt drive, pulley ratio Crank / Fan= 1.0		
Engine oil quantity	ℓ (gal)	Full level 18.0 (4.8) Low level sensor actuation 15.5 (4.1) Oil filter, etc. 4 (1.1)		
Dry weight	kg (lbs)	480 (1,060)		
Fuel consumption ratio		g / PS·h (g / kW·h)		
Allowable inclination (Limited by E/G lubrication)		Front / Rear and Right / Left : 35°		
Dimension (L×W×H)	mm (in)	1,183×684×890 (46.6×26.9×35.0)		
Rotating direction		Counterclockwise seeing from flywheel side		

9.2 ENGINE CHARACTERISTIC CURVE (MITSUBISHI 6D34-T)

Condition to be measured : With fan, alternator and air cleaner
Without muffler

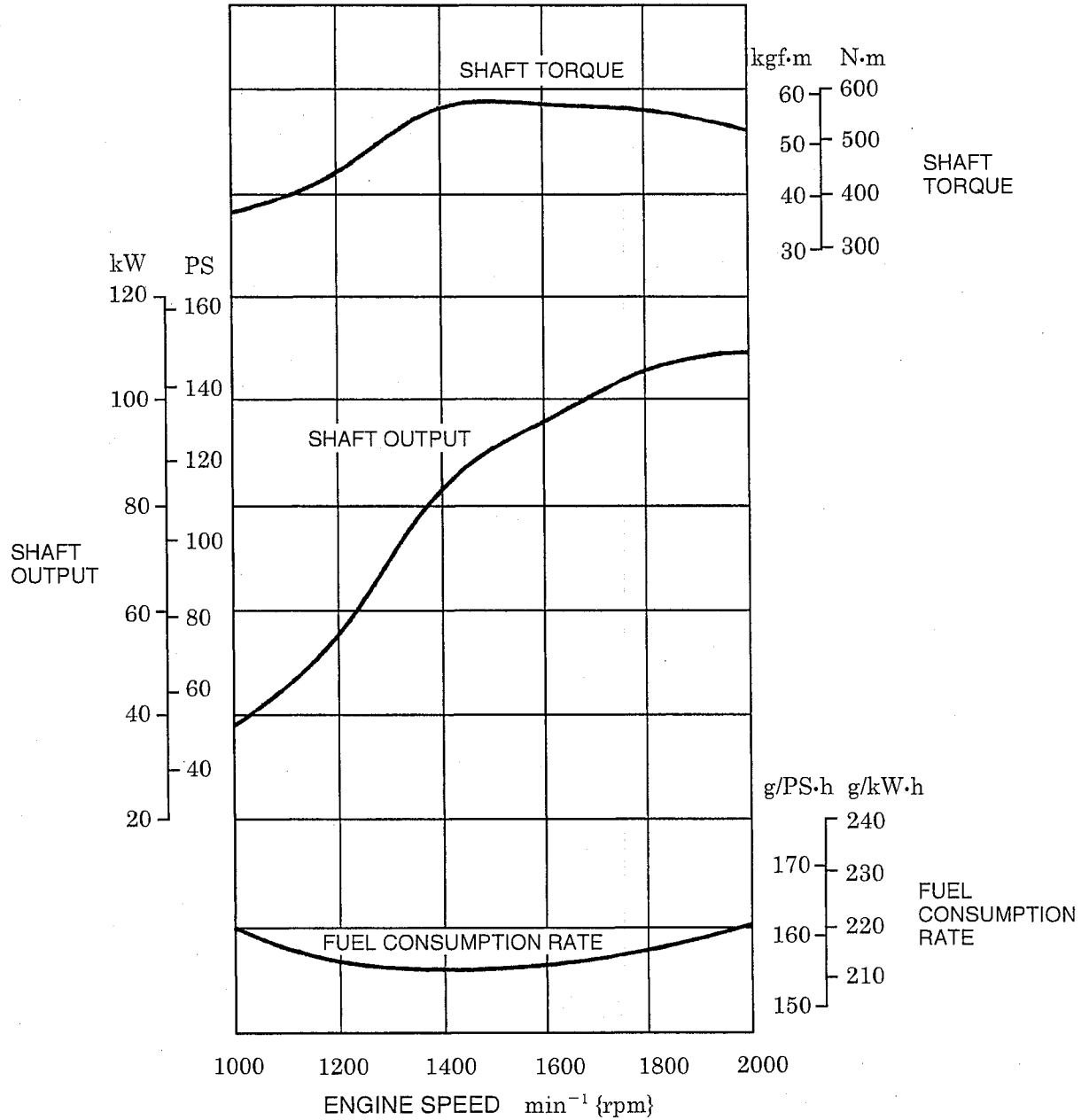

$$\begin{aligned} & \text{Fuel consumption volume} \\ &= \frac{\text{Fuel consumption rate}}{0.835 \times 1000} \times \text{kW} \times \text{Load factor } (\alpha) \\ &= \frac{220 \text{g} / \text{kW} \cdot \text{h}}{0.835 \times 1000} \times 110 \text{kW} \times \alpha \\ &= 29 \alpha \cdot \ell / \text{h} \end{aligned}$$

$$\begin{aligned} & \text{Fuel consumption volume} \\ &= \frac{\text{Fuel consumption rate}}{0.835 \times 1000} \times \text{PS} \times \text{Load factor } (\alpha) \\ &= \frac{162 \text{g} / \text{PS} \cdot \text{h}}{0.835 \times 1000} \times 150 \text{PS} \times \alpha \\ &= 29.1 \alpha \cdot \ell / \text{h} \end{aligned}$$

α : Standard load factor
(0.70~0.80)

Fuel consumption in regular operation
(load factor : 0.70~0.80)
20.4~23.3ℓ/h

KOBELCO

Book code No.

S5 **YN03**_{17E}

SHOP MANUAL **SK200(LC)-6E**
SK210(LC)-6E(S)
SK210NLC-6ES

YN03

— ATTACHMENT DIMENSION —

TABLE OF CONTENTS

1. BOOM	
1.1 Boom dimensional drawing	1
1.2 Boom maintenance standard	2
2. ARM	
2.1 Arm dimensional drawing	5
2.2 Arm maintenance standard	6
3. BUCKET	
3.1 Bucket dimensional drawing	9
3.2 Bucket dimensional table	9
3.3 Detail dimensional drawing of lug section	10
3.4 Detail dimensional drawing of boss section	10

KOBELCO CONSTRUCTION MACHINERY CO., LTD.

Applicable Machines
YN10-38001~
YQ10-05501~

Revision	Date of Issue	Remarks
First edition	November, 2004	S5YN0317E K

1. BOOM

1.1 BOOM DIMENSIONAL DRAWING

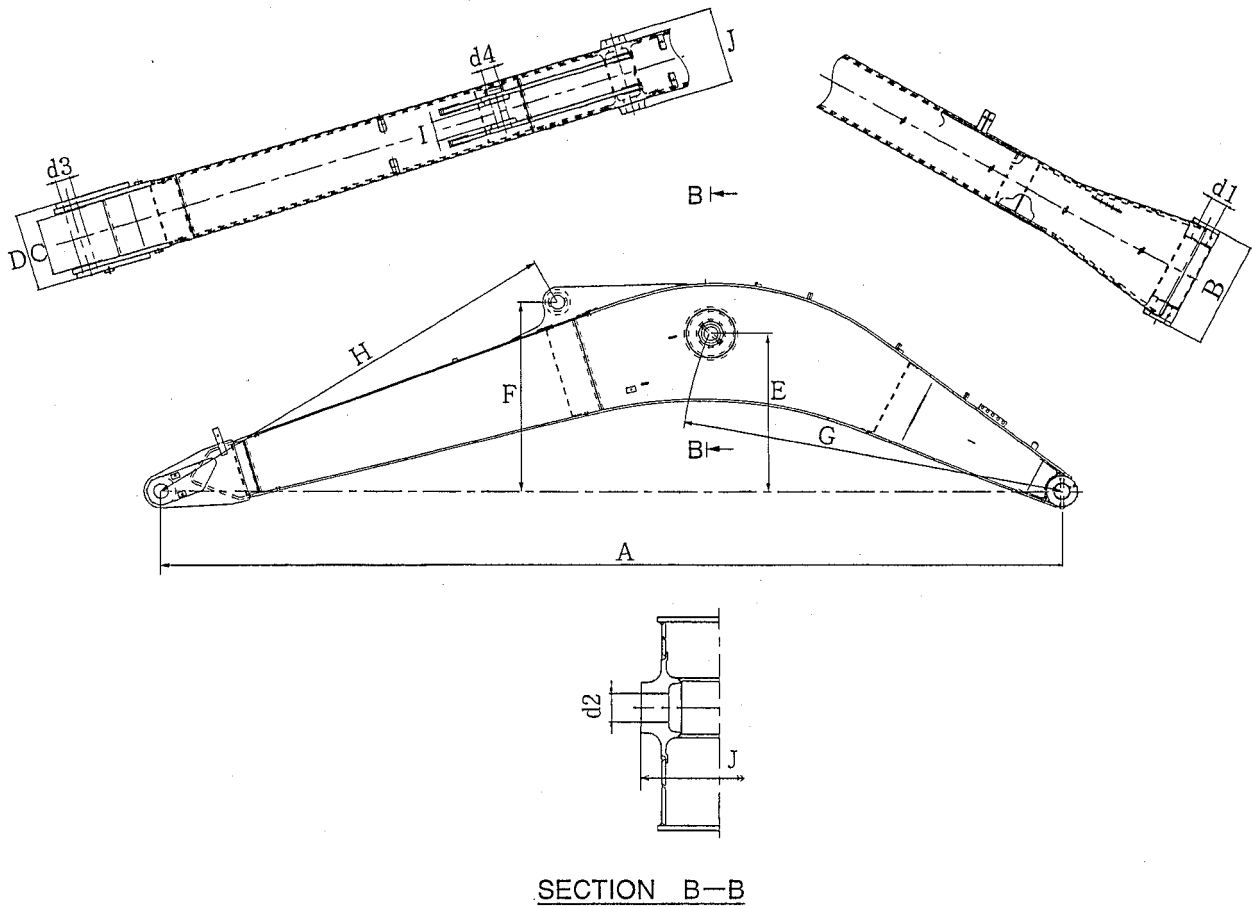

Fig. 1-1 Boom dimensional drawing

Table 1-1

5.65M (18ft-6in) BOOM		YN02B00310F3 ASIA · OCE	Unit : mm (ft-in)
		YN02B00310F1 KCME	
No	NAME	DIMENSION	
A	Boom length	5,650(18' 6")	
B	Boom foot width	670(26.4")	
C	Boom end inner width	347(13.7")	
D	Boom end outer width	482(19")	
E	Height of boom cylinder rod pin	985(38.8")	
F	Height of arm cylinder (head side) pin	1,182(3' 10")	
G	Distance between pins of boss	R2,425(7' 11")	
H	Distance between pins of bracket	R2,750(9' 03")	
I	Arm cylinder (head side) inner width	126(4.96")	
J	Outer width of bracket on the arm cylinder (rod side) mounting	466(18.3")	
d1	Boom foot pin dia.	Ø90(3.54")	
d2	Boom cylinder (rod side) pin dia.	Ø85(3.35")	
d3	Pin dia. of arm end.	Ø90(3.54")	
d4	Arm cylinder (head side) pin dia.	Ø85(3.35")	

1.2 BOOM MAINTENANCE STANDARD

(1A) Clearance of pin and bushing on boom section ASIA

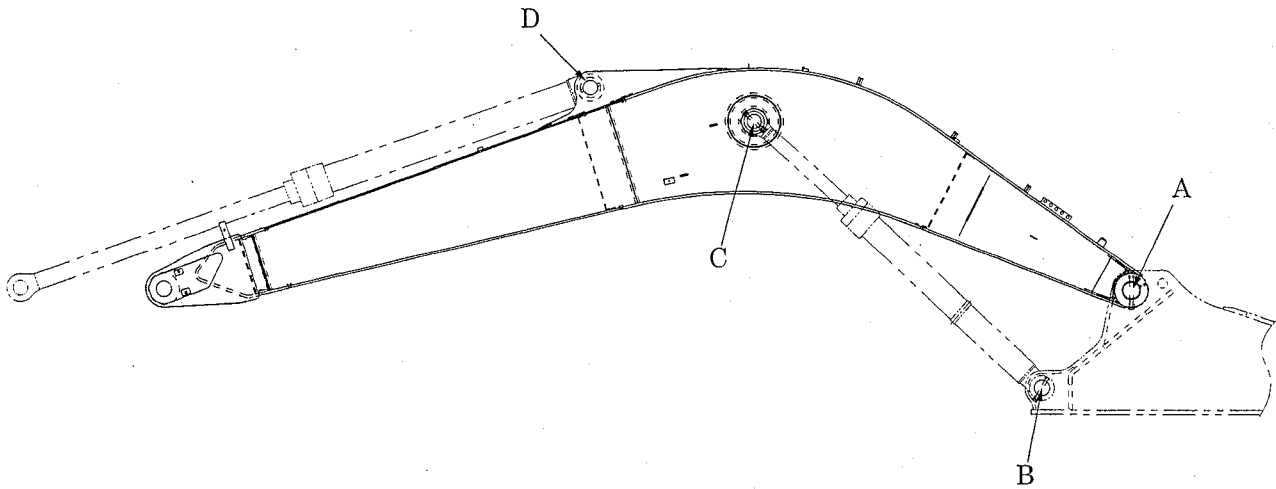

Fig. 1-2 Clearance of pin and bushing on boom section

Table 1-2

Unit : mm (in)

Sym-bol	Item	Pin part No.	Standard value			Clearance			Remedy
			Pin dia.	Pin dia. tolerance	Bushing i.d. tolerance	Standard value	Repairable level	Service limit	
A	Boom foot	YN02B01383P1	Ø90 (3.5433)	+0.020 (+0.0008)	+0.201 (+0.0079)	+0.221 (+0.0087)	More than 2.0 (0.08)	2.5 (0.1)	Replace bushing or pin
B	Boom cylinder (Head side)	YN02B01385P1		-0.020 (-0.0008)	+0.100 (+0.0039)	+0.080 (+0.0031)			
C	Boom cylinder (Rod side)	YN02B01386P1		+0.020 (+0.0008)	+0.223 (+0.0088)	+0.243 (+0.0096)			
D	Arm cylinder (Head side)	YN02B01381P1		-0.020 (-0.0008)	+0.106 (+0.0042)	+0.086 (+0.0034)			
			Ø85 (3.34645)	+0.030 (+0.0012)	+0.230 (+0.0091)	+0.260 (+0.0102)			
				-0.030 (-0.0012)	+0.150 (+0.0059)	+0.120 (+0.0047)			

1.2 BOOM MAINTENANCE STANDARD

(1B) Clearance of pin and bushing on boom section OCE KCME

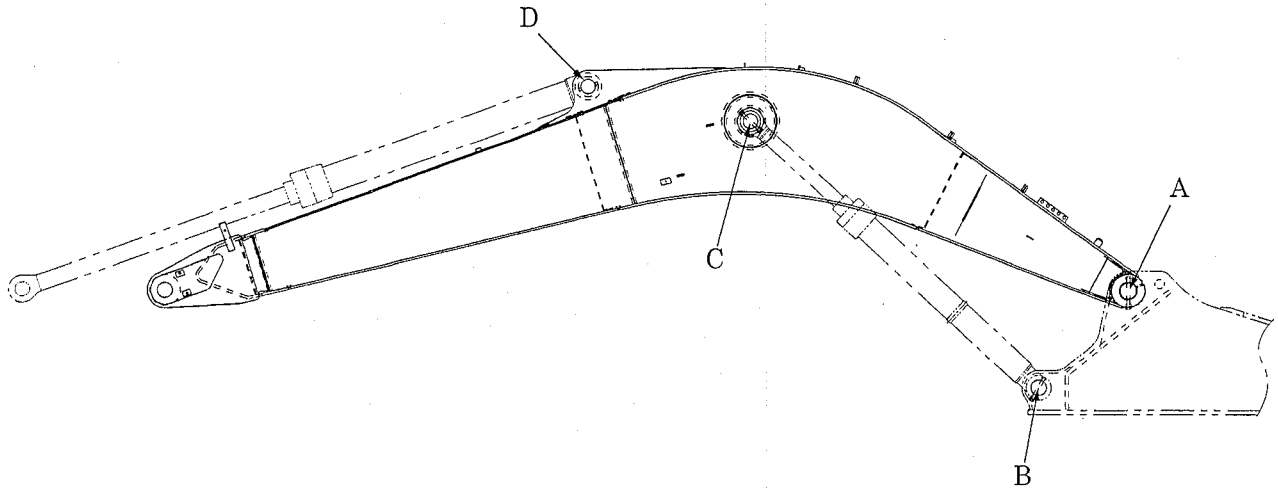

Fig. 1-3 Clearance of pin and bushing on boom section

Table 1-3

Unit : mm (in)

Sym-bol	Item	Pin part No.	Standard value			Clearance			Remedy
			Pin dia.	Pin dia. tolerance	Bushing i.d. tolerance	Standard value	Repairable level	Service limit	
A	Boom foot	YN02B01468P1	Ø90 (3.5433)	+0.020 (+0.0008)	+0.201 (+0.0079)	+0.221 (+0.0087)	More than 1.0 (0.04)	1.5 (0.06)	Replace bushing or pin
B	Boom cylinder (Head side)	YN02B01470P1		-0.020 (-0.0008)	+0.100 (+0.0039)	+0.080 (+0.0031)			
C	Boom cylinder (Rod side)	YN02B01471P1		+0.223 (+0.0088)	+0.243 (+0.0096)	+0.106 (+0.0034)			
D	Arm cylinder (Head side)	YN02B01466P1		+0.222 (+0.0087)	+0.242 (+0.0095)	+0.085 (+0.0033)			
			Ø85 (3.34645)	-0.020 (-0.0008)	+0.217 (+0.0085)	+0.237 (+0.0093)			
					+0.097 (+0.0038)	+0.077 (+0.0030)			

(2) Clearance in thrust direction on the boom cylinder installation section

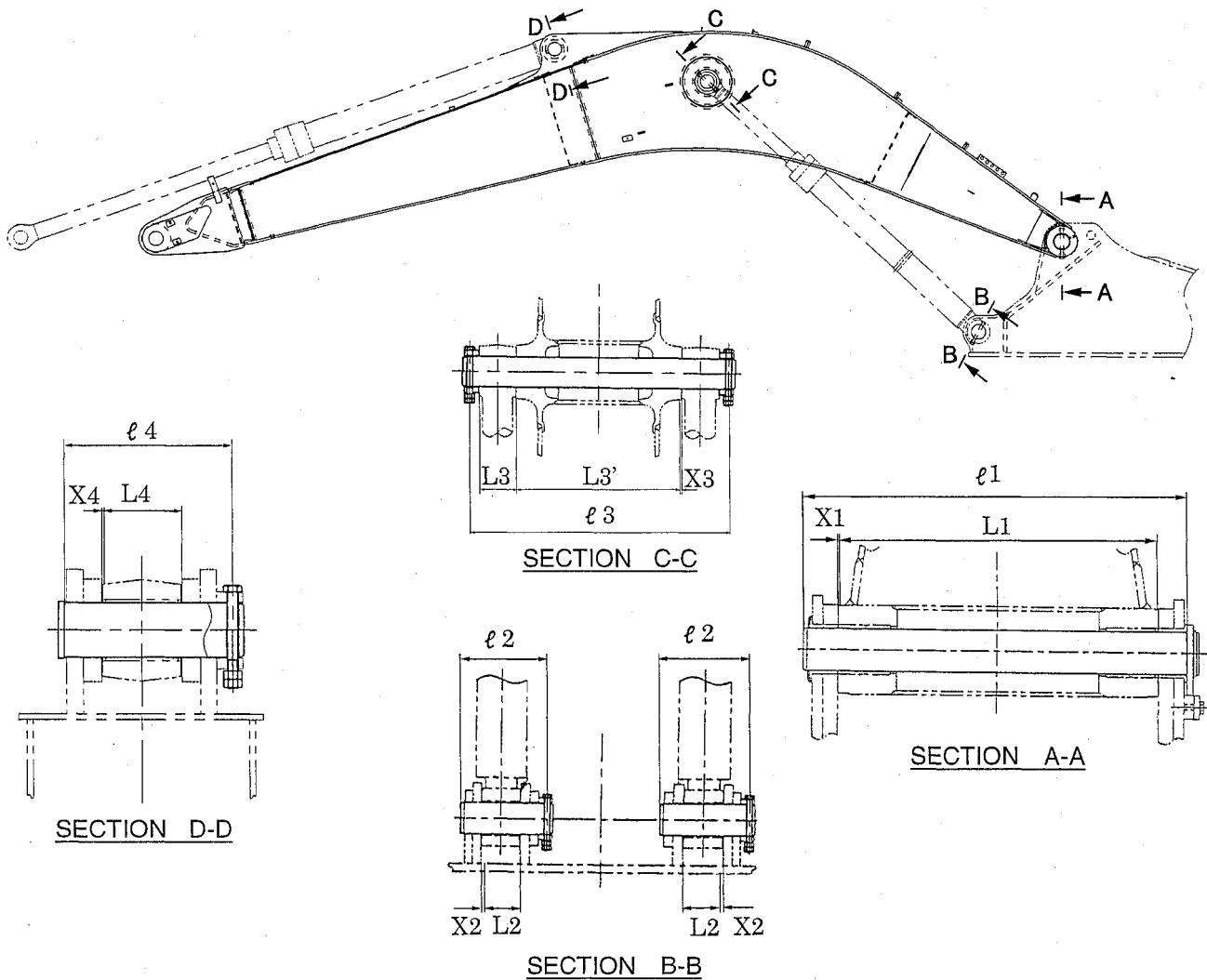

Fig. 1-4 Clearance in thrust direction on the boom cylinder installation section

Table 1-4

Unit : mm (in)

Section	Item		Basic size		Shim adjusting clearance (Total of both sides)			Length under pin neck		Remedy
			Sym-bol	Size	Standard value	Repairable level	Service limit	No.	Length	
A-A	Boom foot	Boom	L1	670(26.4)	0.5(0.02) or less	2.0	2.5	l1	809 (31.9)	Shim adjustment
		Upper frame		676(26.6)						
B-B	Boom cylinder (Head side)	Boom cylinder	L2	110(4.33)	0.6~1.0 (0.02~0.04)	(0.08)	(0.10)	l2	250 (9.84)	
		Upper frame		113(4.45)						
C-C	Boom cylinder (Rod side)	Boom cylinder	L3	105(4.13)	0.6~2.0 (0.02~0.08)	3.0	4.0	l3	734 (28.9)	
		Boom	L3'	466(18.3)						
D-D	Arm cylinder (Head side)	Boom cylinder	L4	120(4.72)	0.6~1.0 (0.02~0.04)	2.0	2.5	l4	254 (10.0)	
		Boom		126(4.96)						

2. ARM

2.1 ARM DIMENSIONAL DRAWING

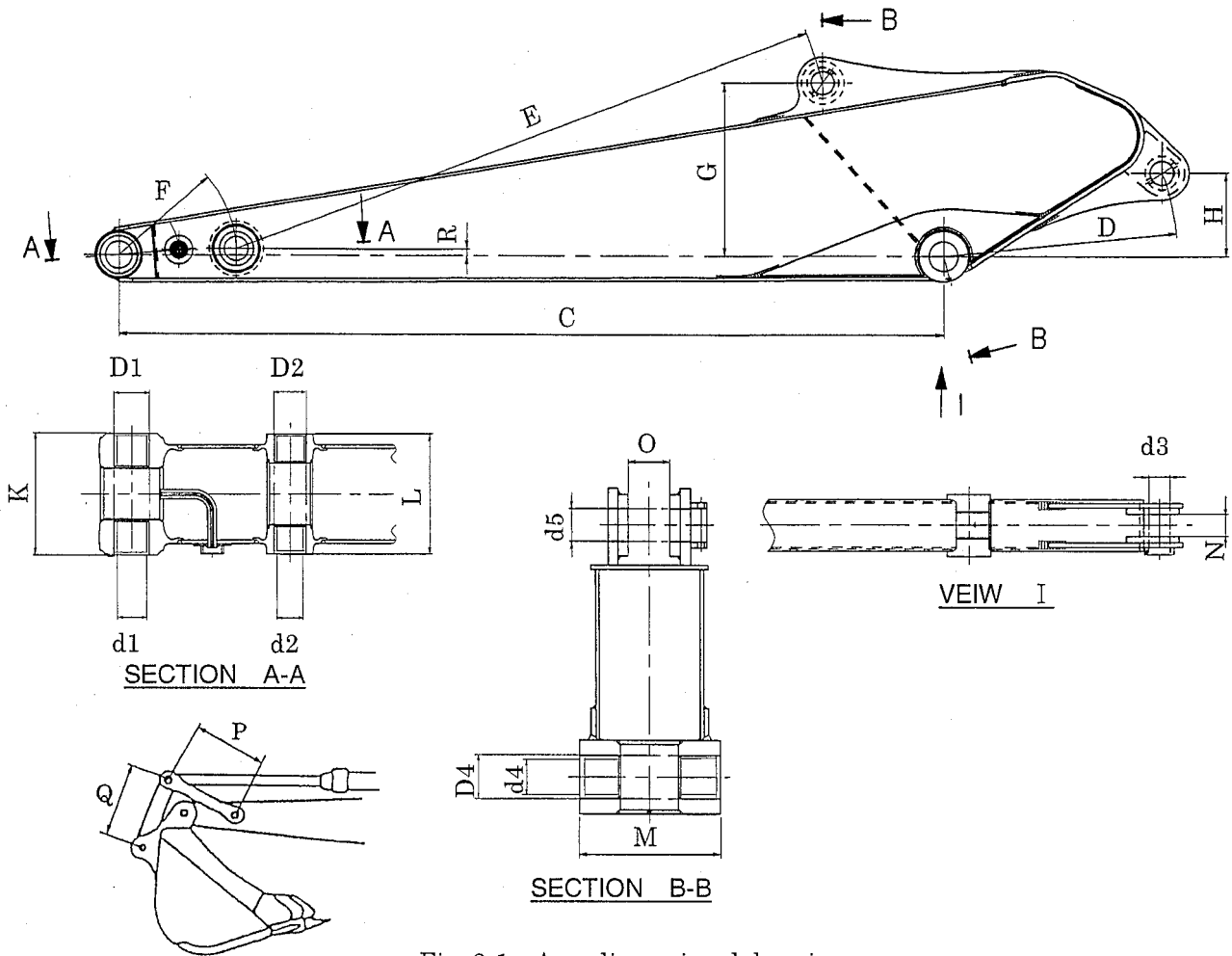

Fig. 2-1 Arm dimensional drawing
Table 2-1

Unit : mm (ft-in)

2.94m (9ft-8in) ARM		YN12B00501F1 ASIA			
		YN12B00388F1 OCE			
		YN12B00486F1 KCME			
Code	NAME	DIMENSION [STD ARM]	No.	NAME	DIMENSION [STD ARM]
C	Arm length	2,940 (9' 8")	M	Boss width	342 (13.5")
D	Distance between pins of boss and bracket	R834 (32.8")	N	Bracket inner width	126 (4.96")
D1	I.D of boss	Ø95 (3.74")	O	Bracket inner width	106 (4.17")
D2	I.D of boss	Ø85 (3.35")	P	Idler link dimension	630 (24.8")
D4	I.D of boss	Ø105 (4.13")	Q	Bucket link dimension	610 (24")
E	Distance between pins of boss and bracket	R2,175 (7' 1.6")	R	Height between pins of boss and center	23 (0.906")
F	Distance between pins of boss and boss	R420 (16.5")	d1	Pin dia.	Ø80 (3.15")
G	Height between pins of boss and bracket	616 (24.3")	d2	Pin dia.	Ø70 (2.76")
H	Height between pins of boss and bracket	298 (11.7")	d3	Pin dia.	Ø85 (3.35")
K	Arm top end boss width	325 (12.8")	d4	Pin dia.	Ø90 (3.54")
L	Arm link section boss width	320 (12.6")	d5	Pin dia.	Ø80 (3.15")

2.2 ARM MAINTENANCE STANDARD

(1A) Clearance of pin and bushing ASIA

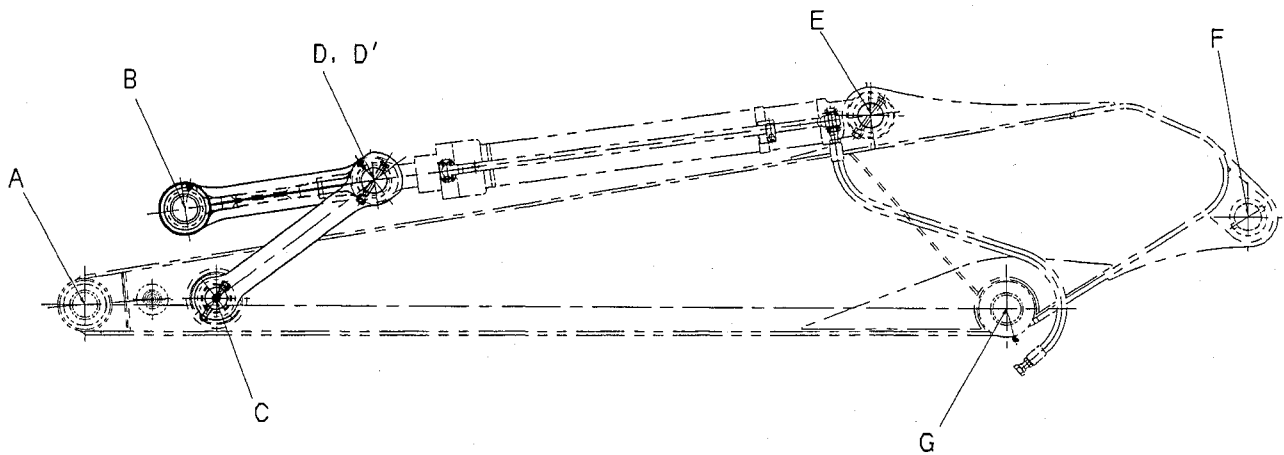

Fig. 2-2 Clearance of pin and bushing on arm section

Table 2-2

Unit : mm (in)

No.	Item	Pin part No.	Standard value			Clearance			Remedy
			Pin dia.	Pin dia. tolerance	Bushing i.d. tolerance	Standard value	Repairable level	Service limit	
A	Arm point	YN12B01632P1	Ø80 (3.1496)	-0.020 (+0.0008) -0.060 (0.0024)	+0.226 (+0.0089)	+0.286 (+0.0113)	2.0 (0.08)	2.5 (0.1)	Replace bushing or pin
B	Bucket link (Bucket connection)				+0.153 (+0.0060)	+0.173 (+0.0068)			
C	Idler link (Arm connection)	YN12B01549P1	Ø70 (2.7559)	+0.000 (+0.0000) -0.060 (-0.0024)	+0.231 (+0.0091)	+0.291 (+0.0115)	2.0 (0.08)	2.5 (0.1)	Replace bushing or pin
D	Bucket link (Idler link connection)	YN12B01550P1	Ø80 (3.1496)		+0.161 (+0.0063)	+0.181 (+0.0071)			
D'	Bucket cylinder (Rod side)			+0.240 (+0.0095)	+0.300 (+0.0118)	+0.290 (+0.0114)	+0.150 (+0.0059)		
E	Bucket cylinder (Head side)	YN12B01544P1	Ø85 (3.3465)	+0.174 (+0.0069)	+0.174 (+0.0069)				
F	Arm cylinder (Rod side)	YN02B01381P1		+0.030 (+0.0012)	+0.230 (+0.0091)	+0.260 (+0.0102)	+0.260 (+0.0102)	+0.120 (+0.0047)	+0.120 (+0.0047)
G	Arm foot	YN12B01517P1	+0.020 (+0.0008)	+0.231 (+0.0091)	+0.251 (+0.0099)				
				-0.020 (-0.0008)	+0.153 (+0.0060)	+0.133 (+0.0052)			

2.2 ARM MAINTENANCE STANDARD

(1B) Clearance of pin and bushing KCME · OCE

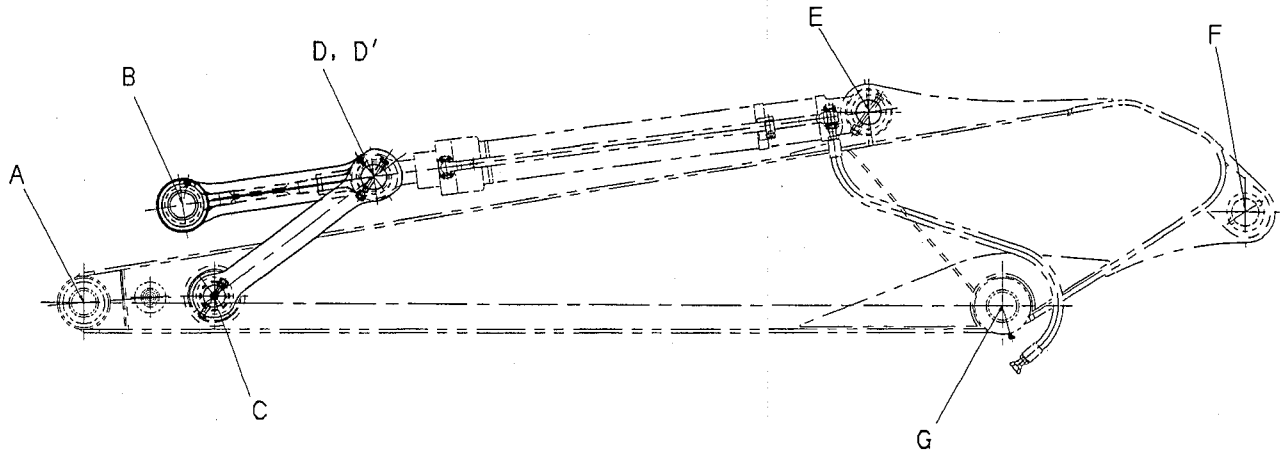

Fig. 2-3 Clearance of pin and bushing on arm section

Table 2-3

Unit : mm (in)

No.	Item	Pin part No.	Standard value			Clearance			Remedy
			Pin dia.	Pin dia. tolerance	Bushing i.d. tolerance	Standard value	Repairable level	Service limit	
A	Arm point	YN12B01716P1	Ø80 (3.1496)	-0.020 (+0.0008) -0.060 (0.0024)	+0.245 (+0.0096)	+0.305 (+0.0120)	1.0 (0.04)	1.5 (0.06)	Replace bushing or pin
B	Bucket link (Bucket connection)				+0.117 (+0.0046)	+0.137 (+0.0054)			
C	Idler link (Arm connection)	YN12B01717P1	Ø70 (2.7559)	+0.000 (+0.0000) -0.040 (-0.0016)	+0.251 (+0.0099)	+0.291 (+0.0115)	1.0 (0.04)	1.5 (0.06)	Replace bushing or pin
D	Bucket link (Idler link connection)	YN12B01718P1	Ø80 (3.1496)		+0.142 (+0.0056)	+0.142 (+0.0056)			
D'	Bucket cylinder (Rod side)			+0.251 (+0.0099)	+0.291 (+0.0115)				
E	Bucket cylinder (Head side)	YN12B01707P1	Ø85 (3.3465)	+0.125 (+0.0049)	+0.125 (+0.0049)	1.0 (0.04)	1.5 (0.06)	Replace bushing or pin	
F	Arm cylinder (Rod side)	YN02B01466P1		+0.219 (+0.0086)	+0.239 (+0.0094)				
G	Arm foot	YN02B01699P1	Ø90 (3.5433)	+0.020 (+0.0008) -0.020 (-0.0008)	+0.100 (+0.0039)	+0.080 (+0.0031)	1.0 (0.04)	1.5 (0.06)	Replace bushing or pin
				+0.217 (+0.0085)	+0.237 (+0.0093)				
				+0.097 (+0.0038)	+0.077 (+0.0030)				
				+0.202 (+0.0080) -0.020 (-0.0008)	+0.222 (+0.0087)	+0.082 (+0.0032)			

(2) Clearance of arm and cylinder installing sections in thrust direction

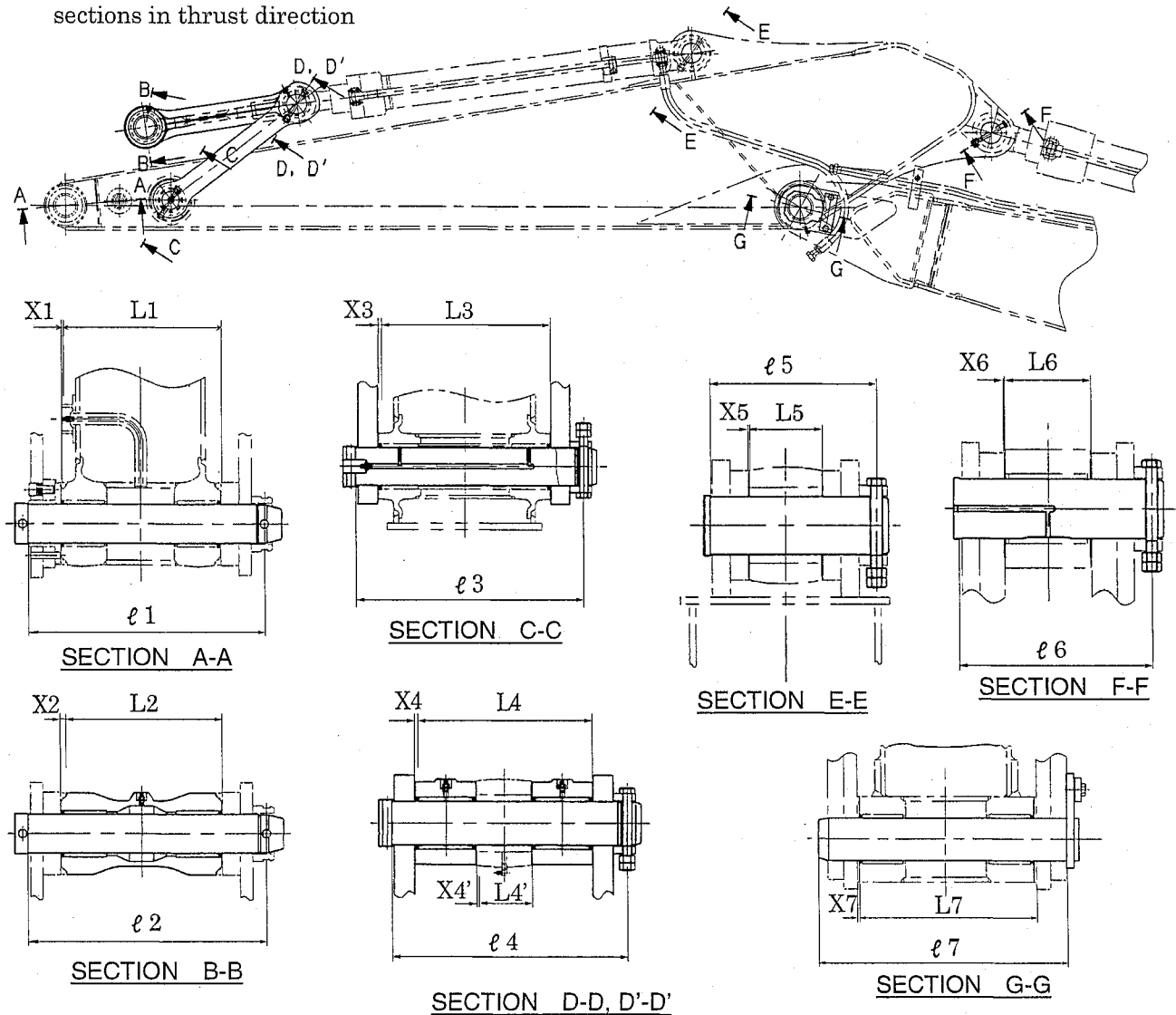

Fig. 2-4 Clearance of arm and cylinder installing sections in thrust direction

Table 2-4

Unit : mm (in)

Section	Item		Basic size		Shim adjusting clearance (Total of both sides)			Length under pin neck		Remedy
			No.	Size	Standard value	Repairable level	Service limit	No.	Length	
A-A	Arm point	Arm	L1	325(12.79)	0.6~1.0 (0.024~0.04)	2.0 (0.08)	2.5 (0.10)	l1	482 (19.0)	Shim adjustment
		Bucket	L1	326(12.83)						
B-B	Bucket link	Link side	L2	325(12.79)	0.6~1.0 (0.024~0.04)	2.0 (0.08)	2.5 (0.10)	l2	425 (16.7)	
		Bucket	L2	327(12.87)						
C-C	Idler link (Arm connection)	Arm	L3	320(12.60)	0.5 (0.02)	1.0 (0.04)	2.5 (0.10)	l3	425 (16.7)	
		Link side	L3	—						
D-D	Bucket link (Idler link connection)	Rod side	L4	320(12.60)	0.6~1.0 (0.024~0.04)	2.0 (0.08)	2.5 (0.10)	l4	425 (16.7)	
		Link side	L4	—						
D'-D'	Bucket link (Rod side)	Rod side	L4'	100(3.94)	0.6~1.0 (0.024~0.04)	2.0 (0.08)	2.5 (0.10)	l4	425 (16.7)	
		Link side	L4'	106(4.17)						
E-E	Bucket cylinder (Head side)	Head side	L5	100(3.94)	0.6~2.0 (0.024~0.08)	3.0 (0.12)	4.0 (0.16)	l5	233 (9.17)	
		Arm	L5	106(4.17)						
F-F	Arm cylinder (Rod side)	Rod side	L6	120(9.72)	0.6~2.0 (0.024~0.08)	3.0 (0.12)	4.0 (0.16)	l6	254 (10.0)	
		Arm	L6	126(4.96)						
G-G	Arm foot	Arm	L7	342(13.46)	0.5 (0.02)	1.0 (0.04)	2.5 (0.10)	l7	503 (19.8)	
		Boom	L7	347(13.66)						

3. BUCKET

3.1 BUCKET DIMENSIONAL DRAWING

(1) Hoe bucket

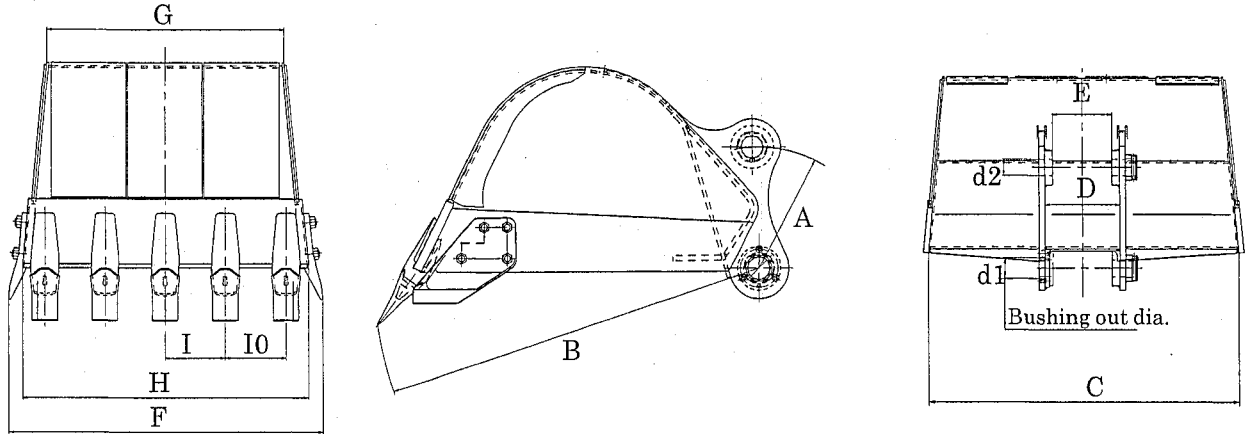

Fig. 3-1 Hoe bucket dimensional drawing

Table 3-1

No.	NAME	No.	NAME
A	Distance between pin and bracket	G	Inner width of bucket bottom
B	Distance between bucket pin and tooth end	H	Bucket outer width of front side
C	Inner width of bucket top end	I	Pitch between teeth
D	Inner width of lug	IO	Pitch between teeth
E	Inner width of bracket	d1	Outer dia. of bushing
F	Outer width of side cutter	d2	Pin dia.

3.2 BUCKET DIMENSIONAL TABLE

Table 3-2

Unit : mm (ft-in)

Type	GD bucket (General Duty)					HD bucket (Heavy Duty)	DD bucket (Demolition Duty)
	[STD] 0.80m ³ (1.05cu.yd)	0.51m ³ (0.67cu.yd)	0.70m ³ (0.92cu.yd)	0.93m ³ (1.21cu.yd)	1.05m ³ (1.37cu.yd)	0.80m ³ (1.05cu.yd)	0.80m ³ (1.05cu.yd)
Part No.	YN61B00145F2	YN61B00191F2	YN61B00160F2	YN61B00158F2	YN61B00159F2	YN61B00165F1	YN61B00164F1
A	R430(16.9")	←	←	←	←	←	←
B	R1,440(4'9")	←	←	←	←	R1,446(4'9")	R1,440(4'9")
C	1,000(3'3")	711(28")	922(36.3")	1,173(3'10")	1,303(4'3")	1,000(3'3")	1,000(3'3")
D	399(15.7")	←	←	←	←	←	←
E	327(12.9")	←	←	←	←	←	←
F	1,157(4')	868(34.2")	1,079(3'6")	1,330(4'4")	1,460(4'9")	1,184(3'11")	1,175(3'10")
G	863(34")	572(22.5")	785(30.9")	1,036(3'5")	1,166(3'10")	863(34")	863(34")
H	1,057(3'6")	766(30.2")	979(38.5")	1,230(4')	1,360(4'6")	1,064(3'6")	1,057(3'6")
I	223(8.78")	300(11.8")	203(7.99")	266(10.5")	238(9.37")	291(11.5")	223(8.78")
IO	223(11")	300(11.8")	203(7.99")	266(10.5")	240(9.45")	291(11.5")	223(8.78")
d1	Ø95(3.74")	←	←	←	←	←	←
d2	Ø80(3.15")	←	←	←	←	←	←



Suggest:

For more complete manuals. Please go to the home page.

<https://www.ebooklibonline.com>

If the above button click is invalid. Please download this document first, and then click the above link to download the complete manual.

Thank you so much for reading

3.3 DETAIL DIMENSIONAL DRAWING OF LUG SECTION

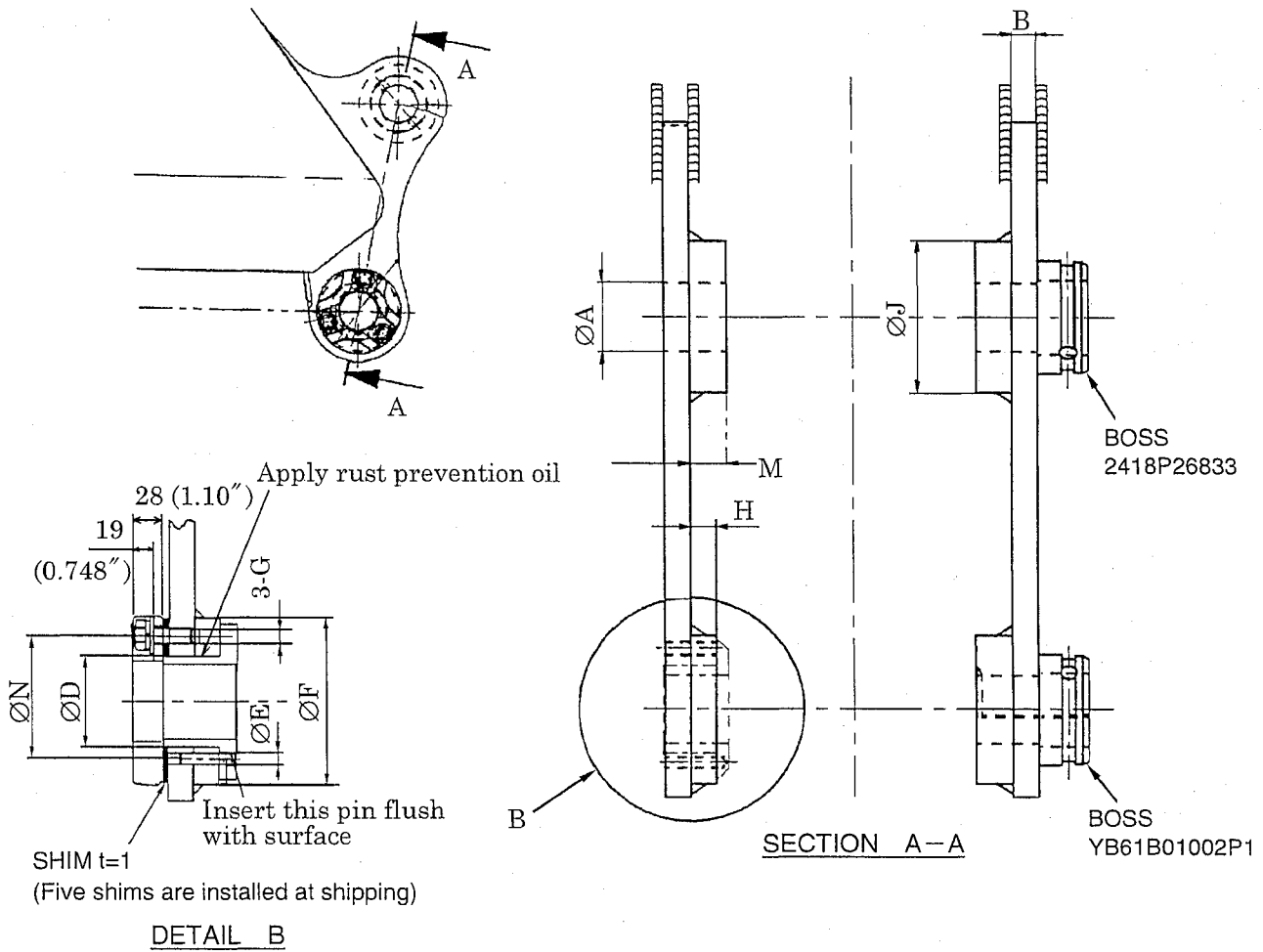

Fig. 3-2 Dimension of lug section

Table 3-3

Unit : mm (ft-in)

Type of bucket	Capacity of bucket m ³ (cu.yd)	Part No. of bucket	Pin hole dia.	Lug plate thickness	Hole dia.	Spring pin dia.	Boss outer dia.	Screw dia.	Boss width.	Boss outer dia.	Boss width.	Screw hole P.C.D
			A	B	D	E	F	G	H	J	M	N
GD bucket	[STD]	YN61B00145F2										
	0.80 (1.05)	YN61B00191F2										
	0.51 (0.67)	YN61B00160F2										
	0.70 (0.92)	YN61B00158F2	Ø80 (3.15")	25 (0.984")	Ø95 (3.74")	Ø13 (0.512")	Ø180 (7.09")	M16	25 (0.984")	Ø170 (6.69")	36 (1.42")	140 (5.51")
	1.05 (1.37)	YN61B00159F2										
HD bucket	0.80 (1.05)	YN61B00165F1										
DD bucket	0.80 (1.05)	YN61B00164F1										

3.4 DETAIL DIMENSIONAL DRAWING OF BOSS SECTION

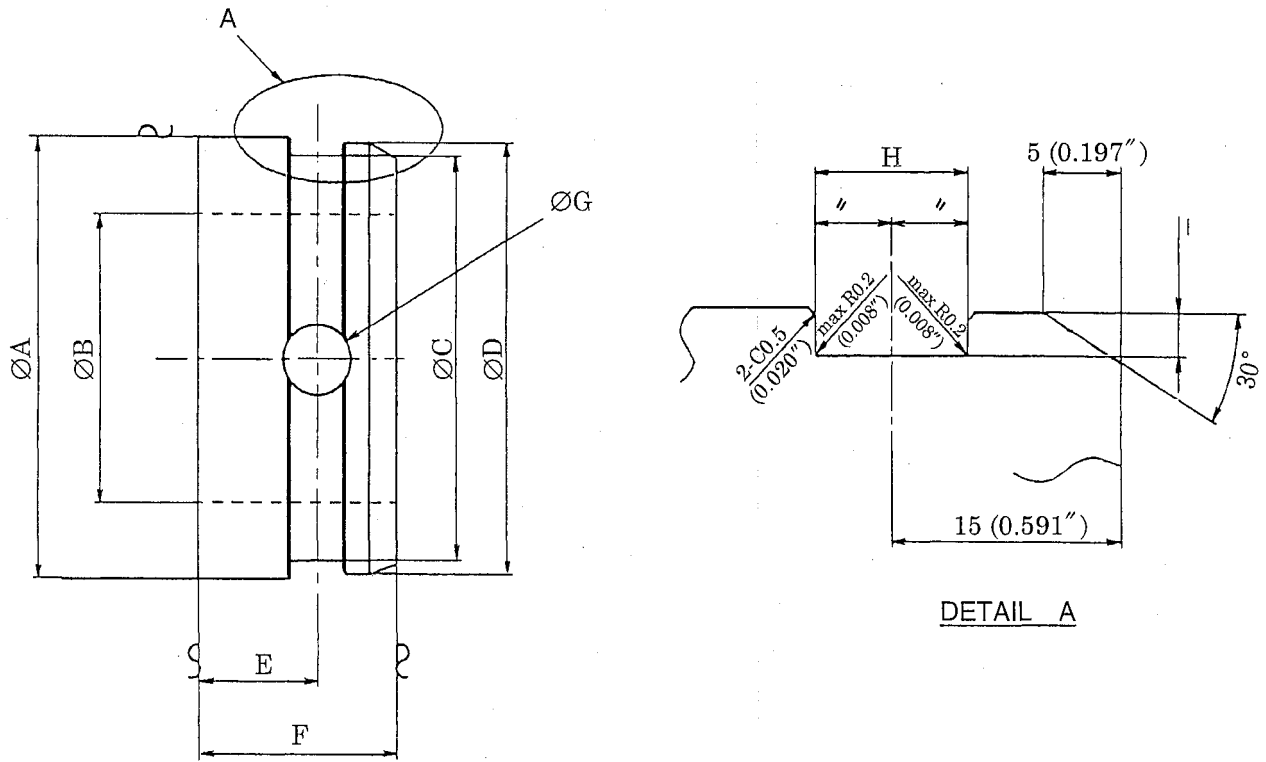

Fig. 3-3 Dimension of boss section

Table 3-4

Unit : mm (ft-in)

Type of bucket	Capacity of bucket m ³ (cu-yd)	Part No. of bucket	Part No. of boss	ØA	ØB	ØC	ØD	E	F	ØG	H	I	
GD bucket	[STD]												
	0.80 (1.05)	YN61B00145F2	2418P26833	114.3	84	105.5	111.5	27	42	17	13	3.0	
	0.51 (0.67)	YN61B00191F2		(4.50")	(3.31")	(4.15")	(4.39")	(1.06")	(1.65")	(0.669")	(0.512")	(0.118")	
	0.70 (0.92)	YN61B00160F2											
	0.93 (1.21)	YN61B00158F2											
	1.05 (1.37)	YN61B00159F2											
HD bucket	0.80 (1.05)	YN61B00165F1	YB61B01002P1	114.3	84	105.5	111.5	23	38	17	13	2.5	
DD bucket	0.80 (1.05)	YN61B00164F1		(4.50")	(3.31")	(4.15")	(4.39")	(0.91")	(1.50")	(0.669")	(0.512")	(0.098")	

<https://www.ebooklibonline.com>

Hello dear friend!

Thank you very much for reading.

Enter the link into your browser.

The full manual is available for immediate download.

<https://www.ebooklibonline.com>