

KOBELCO

SERVICE MANUAL

HYDRAULIC EXCAVATOR

SK70SR-1ES

SK70SR-1ES YT04-07001~

Issued 08-2004

S5YT0003E-01 NA

HYDRAULIC EXCAVATOR

SHOP MANUAL model **SK70SR-1E(S)**

INDEX

1	SPECIFICATIONS SECTION
2	MAINTENANCE SECTION
3	SYSTEM SECTION
4	DISASSEMBLY SECTION
5	TROUBLESHOOTING
6	ENGINE SECTION
7	PROCEDURE OF INSTALLING OPTIONS SECTION

KOBELCO

Book Code No. **S5YT0003E01**

INDEX

SK70SR-1E(S)

Book Code No. Distribution Year-Month			Title	Index No.
S5PW0108E01 2004-9		SPECIFICATIONS	OUTLINE	1
S5YT0203E01 2004-9			SPECIFICATIONS	2
S5YT0303E01 2004-9			ATTACHMENT DIMENSIONS	3
S5YT1103E01 2004-9		MAINTENANCE	TOOLS	11
S5YT1203E01 2004-9			STANDARD MAINTENANCE TIME SCHEDULE	12
S5YT1303E01 2004-9			MAINTENANCE STANDARDS AND TEST PROCEDURES	13
S5YT2103E01 2004-9		SYSTEM	MECHATRO CONTROL SYSTEM	21
S5YT2203E01 2004-9			HYDRAULIC SYSTEM	22
S5YT2303E01 2004-9			ELECTRICAL SYSTEM	23
S5YT2403E01 2004-9			COMPONENTS SYSTEM	24
S5YT2503E01 2004-9			AIR-CONDITIONER SYSTEM	25
—				
S5PW3108E01 2004-9		DISASSEMBLING	DISASSEMBLING & ASSEMBLING	31
S5YT3203E01 2004-9			ATTACHMENTS	32
S5YT3303E01 2004-9			UPPER SWING BODY	33
S5YT3403E01 2004-9			TRAVEL FRAME	34
S5YT4103E01 2004-9		TROUBLESHOOTING	MECHATRO CONTROL	41
S5YT4203E01 2004-9			HYDRAULIC SYSTEM	42
S5YT4303E01 2004-9			ELECTRICAL SYSTEM	43
S5YT4403E01 2004-9			ENGINE	44
S5YT5103E01 2004-9		E/G	ENGINE	51
S5YT6303E01 2004-9		OPT.	MOUNTING THE BREAKER AND NIBBLER & BREAKER	63
—				
—				
YT04-07001~			APPLICABLE MACHINES	

<https://www.ebooklibonline.com>

Hello dear friend!

Thank you very much for reading.

Enter the link into your browser.

The full manual is available for immediate download.

<https://www.ebooklibonline.com>

NOTE:

This Manual is prepared as a technical material in which the information necessary for the maintenance and repairing services of our hydraulic excavators are collected, and is categorized into 7 Chapters, Specification, Maintenance, System, Disassembly, Troubleshooting, Engine, and Installation Procedures for Optional Attachment.

- The Chapter "Specification" describes the specifications for entire machine and material, which are instructive for replacement and repairing of attachments.
- The Chapter "Maintenance" describes the material, which is helpful for maintenance service and adjustments for entire machine.
- The Chapter "System" describes the operating system like hydraulic system, electric system, components, and so on.
- The Chapter "Disassembly" describes the removal and installing of assembly mounted on the upper structure and undercarriage, and the assembling and disassembling of the associated hydraulic equipment.
- The Chapter "Troubleshooting" describes how to find the fault equipment.
- The Chapter "Engine" describes the engines making use of the "Maintenance Manual" provided by the suppliers.
- The Chapter "Installation Procedures for Optional Attachment" describes the supplements added on request as required.

This Manual may be properly revised due to the improvement of products, modification of specifications, etc. And there are cases where the system on actual machine and a part of the contents of this manual may differ due to the variations of specification by countries. For the section in which the description is hardly understood, contact our distributor.

The number is assigned to every part handled in this Manual on account of the description, but the parts, which cannot be supplied as service parts are contained. Therefore, the order must be placed with respective formal number with due confirmation on the Parts Manual for applicable machine.

1. OUTLINE

TABLE OF CONTENTS

- 1.1 GENERAL PRECAUTIONS FOR REPAIRS 1-3
 - 1.1.1 PREPARATION BEFORE DISASSEMBLING 1-3
 - 1.1.2 SAFETY IN DISASSEMBLING AND ASSEMBLING 1-3
 - 1.1.3 DISASSEMBLING AND ASSEMBLING HYDRAULIC EQUIPMENT 1-3
 - 1.1.4 ELECTRICAL EQUIPMENT 1-4
 - 1.1.5 HYDRAULIC PARTS 1-5
 - 1.1.6 WELDING REPAIR 1-5
 - 1.1.7 ENVIRONMENTAL MEASURE 1-5
- 1.2 INTERNATIONAL UNIT CONVERSION SYSTEM(Based on MARKS' STANDARD HANDBOOK FOR MECHANICAL ENGINEERS) 1-6

1. OUTLINE

Issue	Data of Issue	Applicable Machines	Remarks
First Edition	June, 2004	EH30.B : PW11-30001~ EH35.B : PX12-11001~	S5PW0108E01 (NH Australia) KE
↑	↑	SK40SR-3 : PH05-03501~ SK50SR-3 : PJ04-03001~	S5PW0108E01 (KCM Australia) KE
↑	↑	EH50.B : PJ04-03001~	S5PW0108E01 (NH Australia) KE
↑	↑	EH27.B : PV10-27001~	↑ SZ
↑	↑	SK20SR-3 : PM07-07001~ SK27SR-3 : PV10-27001~	S5PW0108E01 (KCM Australia) SZ
↑	↑	SK30SR-3 : PW11-30001~ SK35SR-3 : PX12-11001~	S5PW0108E01 (KCM Australia) KE
↑	August, 2004	SK50SR-3 : PJ04-03001~	S5PW0108E01 (KCM North America) KE
↑	↑	SK30SR-3 : PW11-30001~ SK35SR-3 : PX12-11001~	↑ KE
↑	↑	SK27SR-3 : PV10-27001~	↑ SZ
↑	↑	SK70SR-1E(S) : YT04-07001~	S5PW0108E01 KE

1.1 GENERAL PRECAUTIONS FOR REPAIRS

1.1.1 PREPARATION BEFORE DISASSEMBLING



- (1) Understanding operating procedure
Read OPERATOR'S MANUAL and this MANUAL carefully to understand the operating procedure.
- (2) Cleaning machines
Remove soil, mud, and dust from the machine before carrying it into the service shop to prevent loss of work efficiency, damage of parts, and difficulty in rust prevention and dust protection while reassembling.
- (3) Inspecting machines
Identify the parts to be disassembled before starting work, determine the disassembling procedure by yourself considering the workshop situations etc., and request procurement of necessary parts in advance.
- (4) Recording
Record the following items for communication and prevention of recurring malfunction.
 - 1) Inspection date and place
 - 2) Model name, applicable machine number, and hour meter read
 - 3) Trouble condition, place and cause.
 - 4) Visible oil leakage, water leakage and damage
 - 5) Clogging of filters, oil level, oil quality, oil contamination and loosening of connections
 - 6) Result of consideration if any problem exists based on the operation rate per month calculated from hour meter indication after the last inspection date.
- (5) Arrangement and cleaning in service shop
 - 1) Tools required for repair work.
 - 2) Prepare space to place the disassembled parts.
 - 3) Prepare oil containers for draining oil etc.

1.1.2 SAFETY IN DISASSEMBLING AND ASSEMBLING



- (1) Wear appropriate clothes with long sleeves, safety shoes, safety helmet and protective glasses.

- (2) Suspend warning tag "DO NOT OPERATE" from the doorknob or the operating lever, and have a preliminary meeting before starting work.
- (3) Stop the engine before starting inspection and maintenance to prevent the operator being caught in machine.
- (4) Identify the location of a first-aid kit and a fire extinguisher, and also where to make contact in a state of emergency.
- (5) Choose a hard, level and safe place, and place the attachment on the ground securely.
- (6) Use a lifter such as a crane to remove heavy parts (20 kg [45 lbs] or more) from the machine.
- (7) Use proper tools, and replace or repair defective tools.
- (8) Support the machine and attachment with supports or blocks if the work is performed in the lifted condition.

1.1.3 DISASSEMBLING AND ASSEMBLING HYDRAULIC EQUIPMENT



- (1) Removing hydraulic equipment
 - 1) Before disconnecting pipes, release the hydraulic pressure of the system, or open the return side cover and take out the filter.
 - 2) Carefully drain oil of the removed pipes into a containers without spilling on the floor.
 - 3) Apply plugs or caps on the pipe ends to avoid oil spillage and dust intrusion.
 - 4) Clean off the external surface of the equipment before disassembling, and drain hydraulic and gear oil before placing it on the workbench.
- (2) Disassembling hydraulic equipment
 - 1) Do not disassemble, reassemble or modify the hydraulic equipment without the permission of the manufacturer, who is not responsible for the performance and function of the product after modification.
 - 2) When disassembling and reassembling for unavoidable reason, refer the work to qualified personnel who have the specific knowledge or completed the parts service training.
 - 3) Provide matching marks to facilitate reassembling work.
 - 4) Before starting the work, read the manual of disassembling procedure, if it is provided, and decide whether the work can be performed by yourself.

1. OUTLINE

- 5) Use the special jig and tools without fail if they are specified.
 - 6) If it is hard to remove a part according to the procedure, do not try it by force but investigate the cause.
 - 7) Place the removed parts in order and attach tags to facilitate the reassembling.
 - 8) Note the location and quantity of parts commonly applied to multiple locations.
- (3) Inspecting parts
- 1) Ensure that the disassembled parts are free from seizure, interference and uneven contact.
 - 2) Measure and record wear condition of parts and clearance.
 - 3) If the problem is found in a part, repair or replace it with a new one.
- (4) Reassembling hydraulic equipment
- 1) Turn ON the ventilation fan or open windows to maintain good ventilation prior to starting the cleaning of parts.
 - 2) Perform rough and finish cleaning before assembling.
 - 3) Remove washing oil by air and apply clean hydraulic or gear oil for assembling.
 - 4) Always replace the removed O-rings, backup rings and oil seals with new ones by applying grease in advance.
 - 5) Remove dirt and moisture from and perform degreasing on the surface where liquid gasket to be applied.
 - 6) Remove rust preventive agent from the new parts before use.
 - 7) Fit bearings, bushings and oil seals using special jigs.
 - 8) Assemble the parts utilizing matching marks.
 - 9) Ensure all the parts are completely assembled after the work.
- (5) Installing hydraulic equipment
- 1) Ensure hydraulic oil and lubricant are properly supplied.
 - 2) Perform air bleeding when:
 1. Hydraulic oil changed
 2. Parts of suction side piping replaced
 3. Hydraulic pump installed
 4. Slewing motor installed
 5. Travel motor installed
 6. Hydraulic cylinder installed



Operation of the hydraulic equipment without filling hydraulic oil or lubricant or without performing air bleeding will result in damage to the equipment.

- 3) Perform air bleeding of the hydraulic pump and slewing motor after loosening the upper drain plug, starting the engine and keep it in low idle condition.
Complete the air bleeding when seeping of hydraulic oil is recognized, and tightly plug.
- 4) Perform air bleeding of the travel motor and the hydraulic cylinders by running the engine for more than 5 minutes at low speed without load.



Do not allow the hydraulic cylinder to bottom on the stroke end just after the maintenance.

- 5) Perform air bleeding of pilot line by performing a series of digging, slewing and travel.
- 6) Check hydraulic oil level after placing the attachment to the oil check position, and replenish oil if necessary.

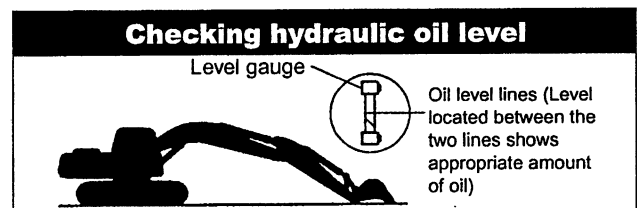

1.1.4 ELECTRICAL EQUIPMENT

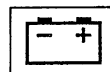

- (1) Do not disassemble electrical equipment.
- (2) Handle it carefully not to drop and give a shock.
- (3) Turn the key OFF prior to connecting and disconnecting work.
- (4) Disconnect the connector by holding it and pressing the lock. Do not pull the wire to apply force to the caulking portion.
- (5) Connect the connector and ensure it is completely locked.
- (6) Turn the key OFF prior to touching the terminal of starter or generator.
- (7) Remove the ground (earth) terminal of battery when handling tools around the battery or its relay.

- (8) Do not splash water on the electrical equipment and connectors during machine washing.
- (9) Check for moisture adhesion inside the waterproof connector after pulling it out, since it is hard to remove moisture from the connector.
If moisture adhesion is found, dry it completely before the connection.



Battery electrolyte is hazardous.

Battery electrolyte is dilute sulfuric acid. Exposure of skin or eyes to this liquid will cause burning or loss of eyesight.

If the exposure occurs, take the following emergency measures and seek the advice of a medical specialist.

- **When skin exposed:**
Wash with water and soap sufficiently.
- **When eyes exposed:**
Immediately wash away with city water continuously for more than 10 minutes.
- **When a large amount of the liquid flows out:**
Neutralize with sodium bicarbonate or wash away with city water.
- **When swallowed:**
Drink a large amount of milk or water.
- **When clothes exposed:**
Immediately undress and wash.

1.1.5 HYDRAULIC PARTS



- (1) O-ring
 - Ensure O-rings have elasticity and are not damaged before use.
 - Use the appropriate O-rings. O-rings are made of various kinds of materials having different hardness to apply to a variety of parts, such as the part for moving or fixed portion, subjected to high pressure, and exposed to corrosive fluid, even if the size is same.
 - Fit the O-rings without distortion and bend.
 - Always handle floating seals as a pair.
- (2) Flexible hose (F hose)
 - Use the appropriate parts. Different parts are used depending on the working pressure even the size of fitting and the total length of the hose is same.

- Tighten the fitting at the specified torque.
Ensure no kink, tension, interference nor oil leakage is recognized.

1.1.6 WELDING REPAIR

- (1) Refer repair welding to qualified personnel according to the appropriate procedure.
- (2) Disconnect the ground (earth) cable of the battery before starting the repair.
Failure to do so will cause damage to the electrical equipment.
- (3) Move away the articles in advance that may cause fire if exposed to sparks.
- (4) Before starting the repair of the attachment, do not fail to cover the plated surface of the piston rod with flameproof sheet to prevent it from being exposed to sparks.

1.1.7 ENVIRONMENTAL MEASURE

- (1) Run the engine at the place that is sufficiently ventilated.
- (2) Industrial waste disposal
Dispose of the following parts according to the relevant regulations:
Waste oil and waste container
Battery
- (3) Precautions for handling hydraulic oil
Exposure of eyes to hydraulic oil will cause inflammation. Wear protective glasses before handling to avoid an accident. If an eye is exposed to the oil, take the following emergency measures:
 - **When an eye exposed:**
Immediately wash away with city water sufficiently till stimulative feeling vanishes.
 - **When swallowed:**
Do not let vomit, and receive medical treatment immediately.
 - **When skin exposed:**
Wash with water and soap sufficiently.
- (4) Others
Use replacement parts and lubricants authorized as the manufacturer's genuine parts.

1. OUTLINE

1.2 INTERNATIONAL UNIT CONVERSION SYSTEM (Based on MARKS' STANDARD HANDBOOK FOR MECHANICAL ENGINEERS)

Introduction

Although this manual includes International System of Unit and Foot-Pound System of Units, if you need SI unit, refer to the following international system of units. Given hereinafter is an excerpt of the units that are related to this manual.

1. Etymology of SI Unites

French : Le Systeme International d' Unites

English : International System of Units

2. Construction of SI Unit System

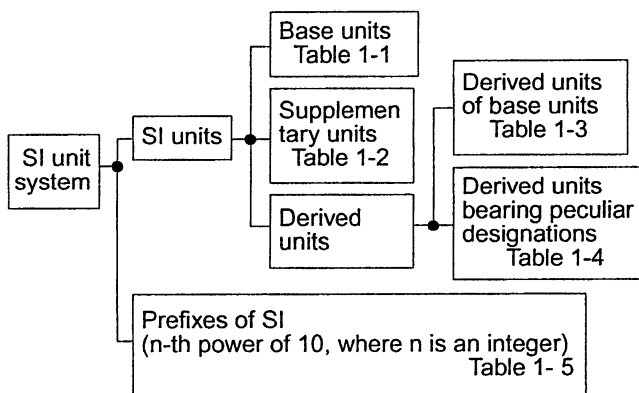

(1) Base units

Table 1-1

QUANTITY	UNIT	SYMBOL
Length	meter	m
Mass	kilogram	kg
Time	second	s
Electric current	ampere	A
Thermodynamic temperature	kelvin	K
Amount of substance	mol	mol
Luminous intensity	candela	cd

(2) Supplementary units

Table 1-2

QUANTITY	UNIT	SYMBOL
Plane angle	radian	rad
Solid angle	steradian	sr

(3) Derived Units

Table 1-3

QUANTITY	UNIT	SYMBOL
Area	square meter	m ²
Volume	cubic meter	m ³
Velocity	meter per second	m/s
Acceleration	meter per second squared	m/s ²
Density	kilogram per cubic meter	kg/m ³

(4) Derived Units bearing Peculiar Designations

Table 1-4

QUANTITY	UNIT	SYMBOL	FORMULA
Frequency	hertz	Hz	1/s
Force	newton	N	kg • m/s ²
Pressure and Stress	pascal	Pa	N/m ²
Energy, Work and Quantity of heat	joule	J	N•m
Power	watt	W	J/s
Quantity of electricity	coulomb	C	A•s
Electric potential difference, Voltage, and Electromotive force	volt	V	W/A
Quantity of static electricity and Electric capacitance	farad	F	C/V
Electric resistance	ohm	Ω	V/A
Celsius temperature	celcius degree or degree	°C	(t+273.15)K
Illuminance	lux	lx	l m/m ²

(5) Prefixes of SI

Table 1-5

PREFIX	SYMBOL	MULTIPLICATION FACTORS
giga	G	10^9
mega	M	10^6
kilo	k	10^3
hecto	h	10^2
deca	da	10
deci	d	10^{-1}
centi	c	10^{-2}
milli	m	10^{-3}
micro	μ	10^{-6}
nano	n	10^{-9}
pico	p	10^{-12}

(6) Unit Conversion

Table 1-6

QUANTITY	Gravitational	SI	CONVERSION FACTOR
Mass	kgf	kg	
Force	kgf	N	1 kgf=9.807 N
Torque	kgf•m	N•m	kgf•m=9.807 N•m
Pressure	kgf/cm ²	MPa	1 kgf/cm ² =0.09807 MPa
Motive Power	PS	kW	1 PS=0.7355 kW
Revolution	rpm	min ⁻¹	r/min *1

*1 Units that are allowed to use.

NOTES

2. SPECIFICATIONS

TABLE OF CONTENTS

- 2.1 NAME OF COMPONENTS 2-3
- 2.2 MACHINE DIMENSIONS 2-4
 - 2.2.1 2.07 M (6 ft-9 in) ARM 2-4
 - 2.2.2 1.65 M (5 ft-5 in) ARM 2-4
- 2.3 WEIGHT OF COMPONENTS 2-5
- 2.4 TRANSPORTATION DIMENSION AND WEIGHT 2-7
- 2.5 SPECIFICATIONS AND PERFORMANCE 2-10
 - 2.5.1 SPEED AND CLIMBING CAPABILITY 2-10
 - 2.5.2 ENGINE 2-10
 - 2.5.3 HYDRAULIC COMPONENTS 2-10
 - 2.5.4 WEIGHT 2-10
- 2.6 TYPE OF CRAWLER 2-11
- 2.7 TYPE OF BUCKET 2-12
- 2.8 COMBINATIONS OF ATTACHMENT 2-13
- 2.9 ENGINE SPECIFICATION 2-14
 - 2.9.1 SPECIFICATIONS 2-14
 - 2.9.2 ENGINE CHARACTERISTIC CURVE (ISUZU 4JG1) (ISUZU 4JG1NABGA) 2-15

2. SPECIFICATIONS

Issue	Date of Issue	Applicable Machines	Remarks
First edition	September, 2004	SK70SR-1E(S) : YT04-07001~	S5YT0203E01 KE

2.1 NAME OF COMPONENTS

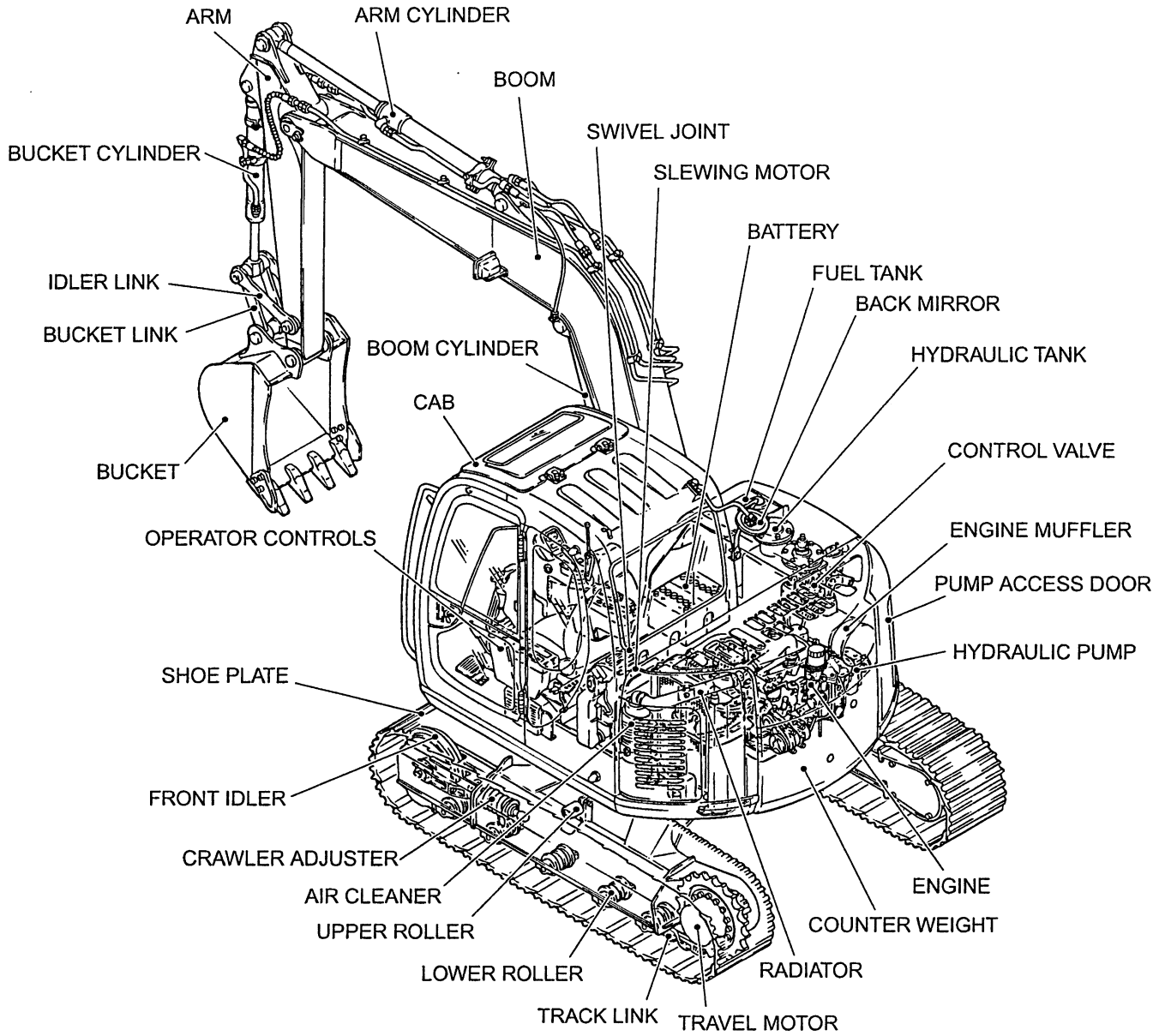

2. SPECIFICATIONS

2.2 MACHINE DIMENSIONS

2.2.1 2.07 M (6 ft-9 in) ARM

Unit: mm (ft-in)

Reference : Arm cylinder pin A position (Working position)

Working height : 2920 mm (9 ft-7 in)

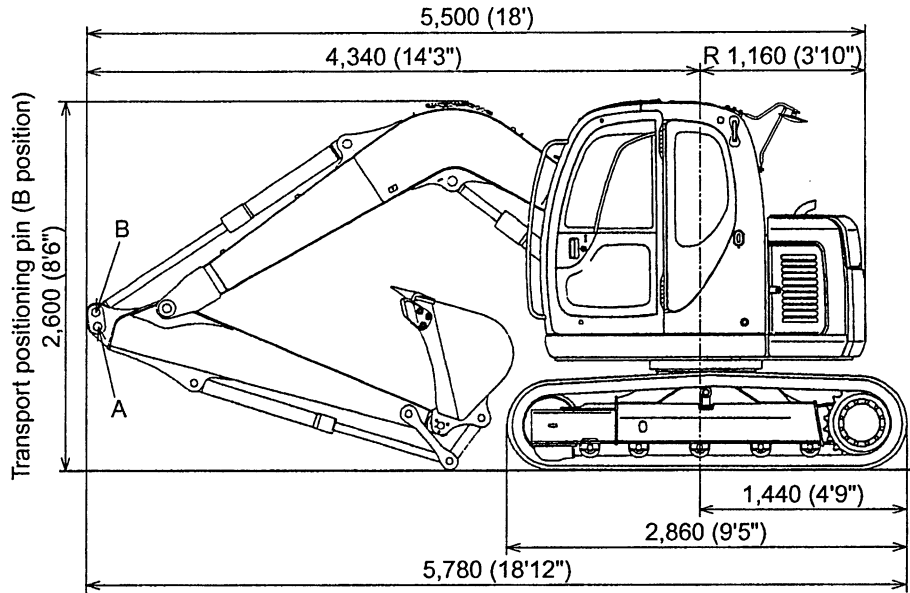

2.2.2 1.65 M (5 ft-5 in) ARM

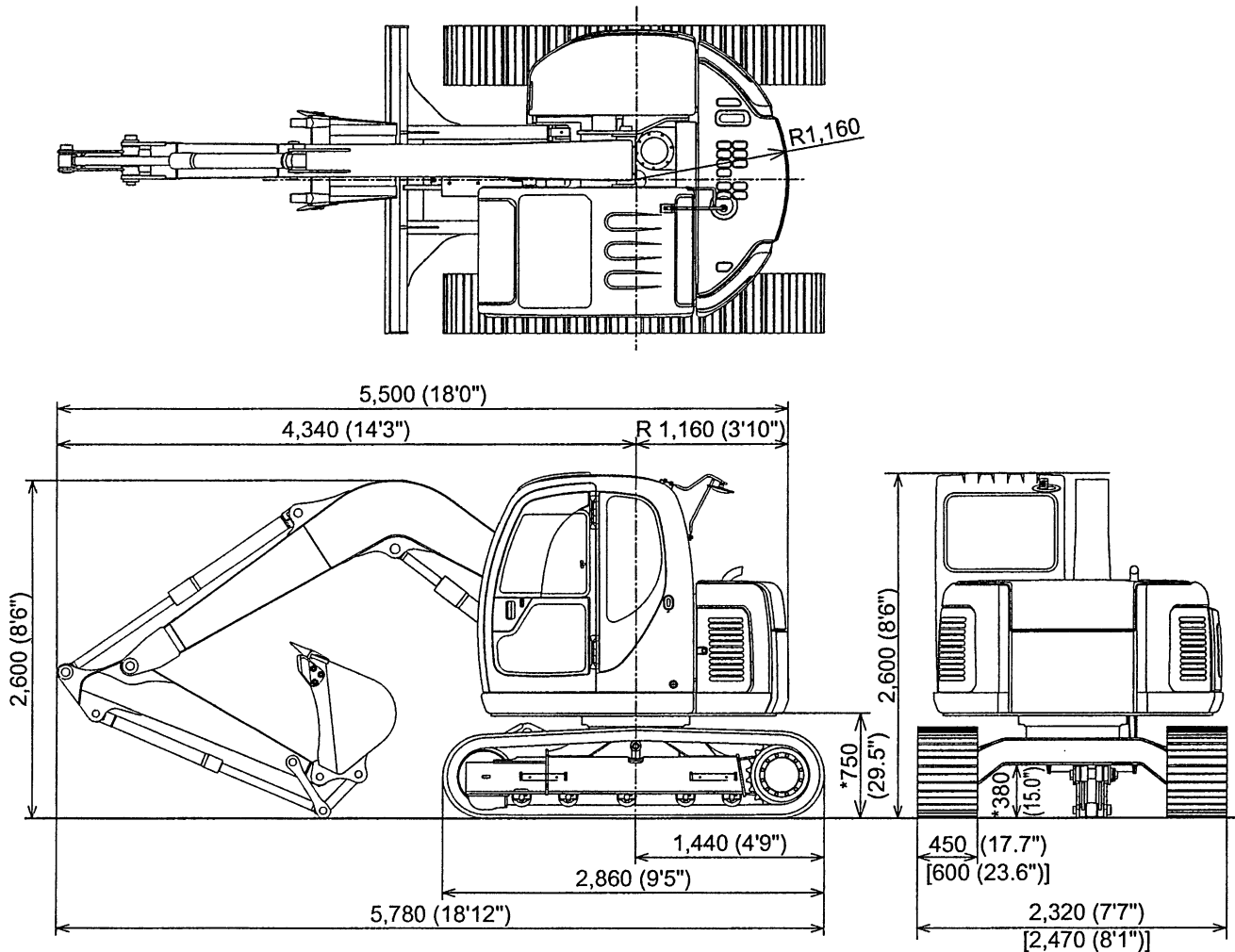

*Marked dimensions do not include height of shoe lug.

2.3 WEIGHT OF COMPONENTS

Unit : kg (lbs)

Item	Model	2.07 M (6 ft-9 in) Arm +450 mm (17.7 in shoe)
Machine complete		7,190 (15,850)
1. Upper frame assy (including the following :)		3,196 (7,050)
1.1 Counterweight		820 (1,810)
Counterweight (Add-on)		400 (880)
1.2 Cab		191 (420)
1.3 Engine		*250 (550)
1.4 Hydraulic oil tank		*68 (150)
1.5 Fuel tank		*53 (120)
1.6 Slewing motor (including reduction unit)		67 (150)
1.7 Control valve		48 (106)
1.8 Boom cylinder		*92 (200)
1.9 Pin (2pcs. for mounting boom)		14 (31)
1.10 Pump		44 (97)
1.11 Radiator		*39 (86)
2. Lower frame assy (including the following :)		2,854 (6,290)
2.1 Slewing bearing		115 (250)
2.2 Travel motor (including reduction unit)		90 (200) × 2
2.3 Upper roller		4 (9) × 2
2.4 Lower roller		15 (33) × 10
2.5 Front idler		44 (97) × 2
2.6 Track tension adjuster		29 (64) × 2
2.7 Sprocket		27 (59) × 2
2.8 Swivel joint		21 (46)
2.9 Dozer blade		305 (670)
2.10 Dozer blade cylinders		*55 (120)
2.11 Track link with 450 mm (17.7 in) shoes assy		421 (928) × 2
Track link with 600 mm (23.6 in) shoes assy		503 (1,110) × 2
Track link with 600 mm (23.6 in) triangle shoes assy		470 (1,040) × 2
2.11.1 Track link assy		155 (340) × 2
3 Attachment		
{3.72 m (12 ft-2 in) Boom+2.07 m (6 ft-9 in) Arm+0.22 m ³ (0.28 cu•yd) Bucket}		982 (2,165)
3.1 Bucket assy		190 (420)
3.2 Arm assy (including the following :)		303 (670)
3.2.1 Arm		180 (400)
3.2.2 Bucket cylinder		48 (106)
3.2.3 Idler link		6 (13) × 2
3.2.4 Bucket link		8 (17) × 2
3.2.5 Pin (2 pcs. for mounting bucket cylinder / 2 pcs. for mounting bucket)		*17 (37)
3.3 Boom assy (including the following :)		490 (1,080)
3.3.1 Boom		390 (860)
3.3.2 Arm cylinder		72 (160)
3.3.3 Pin (Mounting arm • Mounting arm cylinder)		16 (35)

2. SPECIFICATIONS

Item	Model
4. Lubricant and water (including the following :)	2.07 M (6 ft-9 in) Arm +450 mm (17.7 in shoe)
4.1 Hydraulic oil	161 (355)
4.2 Engine oil	68 (150)
4.3 Fuel	9 (20)
4.4 Water	71 (157)
	10 (22)

Note

Numerical values marked * indicate the dry weight.

2.4 TRANSPORTATION DIMENSION AND WEIGHT

OVERALL DIMENSIONS OF MACHINE ON A TRAILER

OVERALL DIMENSIONS OF A COMPLETE MACHINE ON A TRAILER

Item	Type	2.07 M (6 ft-9 in) Arm + 600 mm (23.6 in) shoes	2.07 M (6 ft-9 in) Arm + 450 mm (17.7 in) shoes
Width	m (ft-in)	2,470 (8'1")	2,320 (7'7")
Weight	kg (lb)	6,920 (15,260)	6,700 (14,770)

Specification :

- The parenthesis shows 2.07m arm model.
- Regarding 2.07m arm machine, put the arm cylinder rod in a transport position (B) by referring to the outside dimensions in 2.2 MACHINE DIMENSIONS.

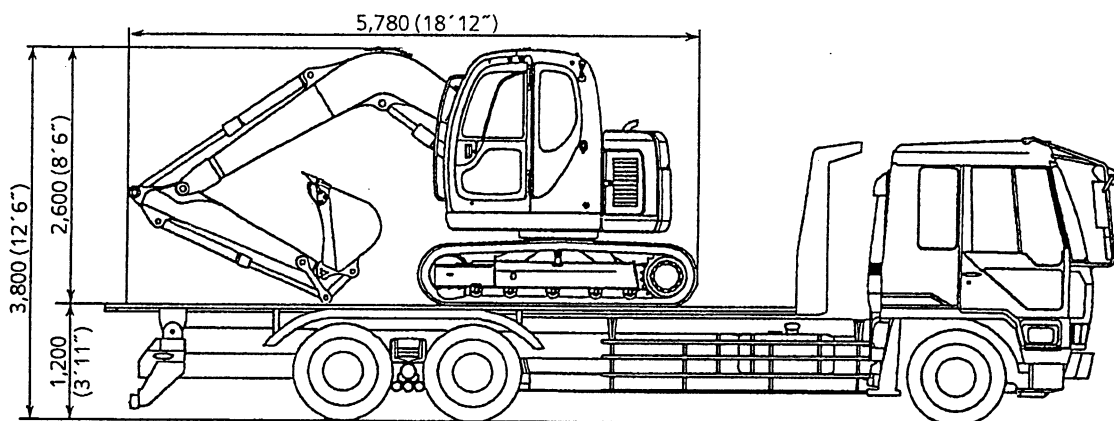

OVERALL DIMENSIONS OF WITHOUT ARM AND BUCKET

Combination	Type	A : Shoe width mm (ft-in)	L : Length mm (ft-in)	H : Height mm (ft-in)	W : Width mm (ft-in)	Weight mm (ft-in)
Without arm and bucket		600 (23.6")	5,670 (18'7")	2,600 (8'6")	2,470 (8'1")	6,440 (14,200)
		450 (17.7")	5,670 (18'7")	2,600 (8'6")	2,320 (7'7")	6,220 (13,715)

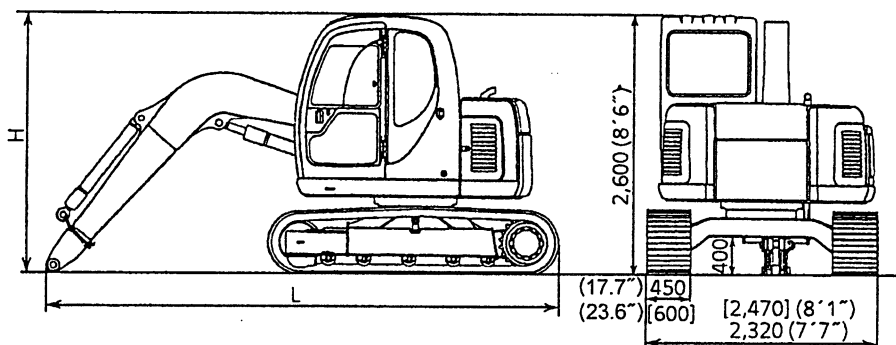

2. SPECIFICATIONS

OVERALL DIMENSIONS OF WITHOUT BOOM, ARM AND BUCKET

Combination	Type	A : Shoe width mm (ft-in)	L : Length mm (ft-in)	H : Height mm (ft-in)	W : Width mm (ft-in)	Weight mm (ft-in)
Without boom, arm and bucket		600 (23.6")	2,860 (9'5")	2,600 (8'6")	2,470 (8'1")	5,950 (13,120)
		450 (17.7")	2,860 (9'5")	2,600 (8'6")	2,320 (7'7")	5,730 (12,630)

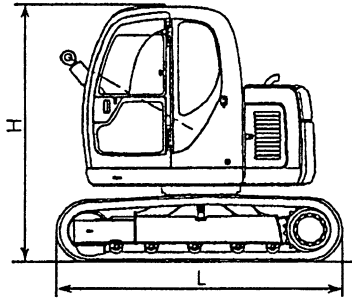

OVERALL DIMENSIONS OF BOOM

Item	Type	3.72 m (12 ft-2 in) Boom
Length × Height × Width L × H × W	m (ft-in)	3.86 × 1.43 × 0.36 (12'8 × 4'8 × 1'2)
Weight	kg (lb)	490 (1,080)

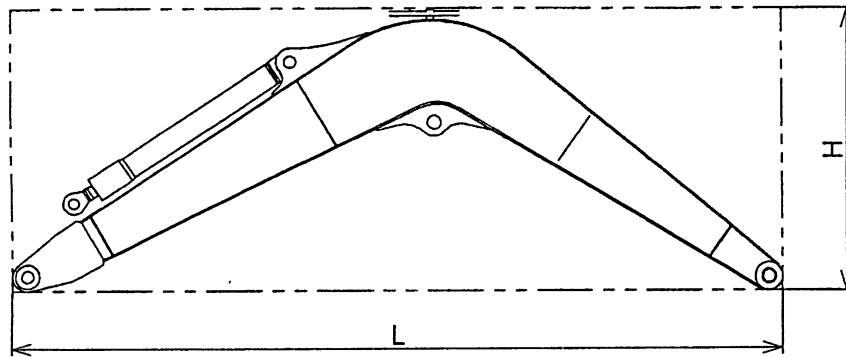

OVERALL DIMENSIONS OF ARM + BUCKET

Item	Type	1.65 m (5 ft-5 in) Arm+ 0.28 m³ (0.37 cu•yd) Bucket	2.07 m (6 ft-9 in) Arm+ 0.22 m³ (0.29 cu•yd) Bucket
Length × Height × Width L × H × W	m (ft-in)	3.14 × 0.70 × 0.75 (10'4" × 2'4" × 2'6")	3.61 × 0.71 × 0.65 (11'10" × 2'2.4" × 2'2")
Weight	kg (lb)	450 (990)	480 (1,060)

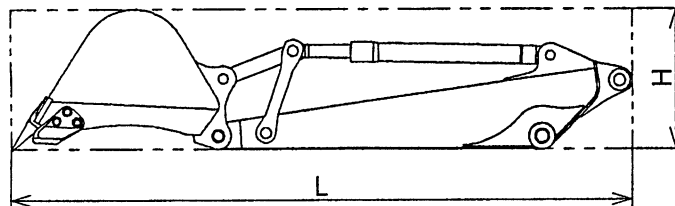



Suggest:

For more complete manuals. Please go to the home page.

<https://www.ebooklibonline.com>

If the above button click is invalid. Please download this document first, and then click the above link to download the complete manual.

Thank you so much for reading

OVERALL DIMENSIONS OF ARM

Item	Type	1.65 m (5 ft-5 in) Arm	2.07 m (6 ft-9 in) Arm
Length x Height x Width L x H x W	m (ft-in)	2.17 x 0.53 x 0.36 (7'1" x 1'9" x 1'2")	2.64 x 0.53 x 0.36 (8'8" x 1'9" x 1'2")
Weight	kg (lb)	250 (550)	290 (640)

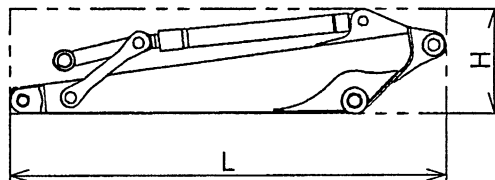

OVERALL DIMENSIONS OF BUCKET

Type	Hoe bucket			
Length x Height x Width L x H x W	1.10 x 0.60 x 0.40 (3'7" x 1'12" x 1'4")	0.98 x 0.89 x 0.48 (3'3" x 2'11" x 1'7")	0.98 x 0.89 x 0.55 (3'3" x 2'11" x 1'10")	0.98 x 0.89 x 0.65 (3'3" x 2'11" x 2'2")
Weight	kg (lbs)	150 (330)	150 (330)	170 (380)
Bucket capacity	m³ (cu•yd)	0.11 (0.14)	0.14 (0.18)	0.18 (0.23)

Type	Hoe bucket		V-bucket	Slope finishing bucket
Length x Height x Width L x H x W	0.98 x 0.89 x 0.75 (3'3" x 2'11" x 2'6")	0.98 x 0.89 x 0.85 (3'3" x 2'11" x 2'9")	1.08 x 0.47 x 1.41 (3'6" x 1'6" x 4'7")	0.79 x 0.62 x 1.50 (2'7" x 2'0" x 4'11")
Weight	kg (lbs)	200 (440)	180 (340)	300 (660)
Bucket capacity	m³ (cu•yd)	0.28 (0.37) STD	0.24 (0.31)	0.26 (0.34)

• Hoe bucket

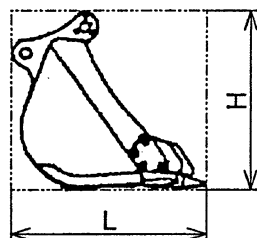

• V-bucket

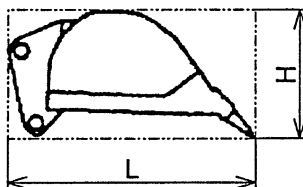

• Slope finishing bucket

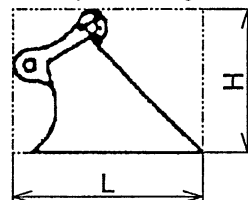

2. SPECIFICATIONS

2.5 SPECIFICATIONS AND PERFORMANCE

2.5.1 SPEED AND CLIMBING CAPABILITY

Model & Shoe spec.		SK70SR-1E(S)	
Item		Iron shoe	Rubber shoe
Swing speed	rpm {min ⁻¹ }	12.5 {12.5}, 11.5 {11.5} (for EU spec.)	
Travel speed	km/h	3.1 / 5.5	3.2 / 5.5
Gradeability	% (degree)	70 (35)	

2.5.2 ENGINE

Engine model	ISUZU CC-4JG1, ISUZU 4JG1NABGA (for EU spec.)
Type	Water-cooled 4-cycle direct injection type engine
Number of cylinders-Bore × Stroke	4-95.4 mm × 107 mm (3.76 in × 4.21 in)
Total displacement	3,059 cc (187 cu•in)
Rated output / Rotation speed	40.5 kw / 2,000 rpm (55 PS / 2,100 rpm)
Maximum torque / Rotation speed	187 N•m (138 ft•lbs) / 1,800 rpm
Starter	24 V / 3.2 kW
Alternator	24 V / 30A

2.5.3 HYDRAULIC COMPONENTS

Hydraulic pump	Variable displacement axial piston+gear pump
Hydraulic motor (Swing)	Axial piston motor
Hydraulic motor (Travel)	2-speed axial piston motor
Control valve	6-spool control valve, 1-spool control valve (Dozer)
Cylinder (Boom, arm, and Bucket)	Double action cylinder
Oil cooler	Air-cooled type

2.5.4 WEIGHT

Unit : kg (lbs)

Fully equipped weight	6,940 (15,300)	7,180 (15,830)
Upper structure	3,250 (7,170)	←
Lower machinery (With 600 mm (23.6 in) grouser shoe)	2,370 (5,230)	—
(With 450 mm (17.7 in) grouser shoe)	—	2,590 (5,710)
Attachment [Boom+2.07 m (6 ft-9 in) Arm +0.22 m ³ (0.29 cu•yd) bucket]	1,080 (2,380)	—
[Boom+1.65 m (5 ft-5 in) Arm +0.28 m ³ (0.37 cu•yd) bucket]	—	1,110 (2,450)

<https://www.ebooklibonline.com>

Hello dear friend!

Thank you very much for reading.

Enter the link into your browser.

The full manual is available for immediate download.

<https://www.ebooklibonline.com>