

KOBELCO

SERVICE MANUAL

HYDRAULIC EXCAVATOR

SK70SR-1E

Applicable: SK70SR-1E YT02-04001~

HYDRAULIC EXCAVATOR

SHOP MANUAL model **SK70SR-1E**

INDEX

1	SPECIFICATIONS SECTION
2	MAINTENANCE SECTION
3	SYSTEM SECTION
4	DISASSEMBLY SECTION
5	TROUBLESHOOTING
6	ENGINE SECTION
7	PROCEDURE OF INSTALLING OPTIONS SECTION

MAINTENANCE SPECIFICATIONS

SYSTEM

DISASSEMBLING

TROUBLESHOOTING
E/G

KOBELCO

00-0-1①

Book Code No. S5YT0002E②

SK70SR-1E Index of shop Manual

Book Code No. Issued Year-Month			Title	Index No.
S5YT0102E 2002-01		SPECIFICATIONS	OUTLINE	YT01
S5YT0202E 2002-01			SPECIFICATIONS	YT02
S5YT0302E 2002-01			ATTACHMENT DIMENSIONS	YT03
S5YT1102E 2002-01		MAINTENANCE	TOOLS	YT11
S5YT1202E 2002-01			STANDARD MAINTENANCE TIME SCHEDULE	YT12
S5YT1302E 2002-01			MAINTENANCE STANDARDS AND TEST PROCEDURES	YT13
S5YT2102E 2002-01		SYSTEM	MECHATRO CONTROL SYSTEM	YT21
S5YT2202E 2002-01			HYDRAULIC SYSTEM	YT22
S5YT2302E 2002-01			ELECTRICAL SYSTEM	PJ23
S5YT2402E 2002-01			COMPONENTS SYSTEM	YT24
S5YT2502E 2002-01			AIR-CONDITIONER SYSTEM	YT25
—			—	
S5YT3102E 2002-01		DISASSEMBLING	DISASSEMBLING & ASSEMBLING	YT31
S5YT3202E 2002-01			ATTACHMENTS	YT32
S5YT3302E 2002-01			UPPER SWING BODY	YT33
S5YT3402E 2002-01			TRAVEL FRAME	YT34
S5YT4102E 2002-01		TROUBLESHOOTING	MECHATRO CONTROL	YT41
S5YT4202E 2002-01			HYDRAULIC SYSTEM	YT42
S5YT4302E 2002-01			ELECTRICAL SYSTEM	YT43
S5YT4402E 2002-01			ENGINE	YT44
S5YT5102E 2002-01		E/G	ENGINE	YT51
S5YT6302E① 2002-12		OPT	MOUNTING THE BREAKER AND NIBBLER & BREAKER	YT63
YT02-04001~			APPLICABLE MACHINES	

<https://www.ebooklibonline.com>

Hello dear friend!

Thank you very much for reading.

Enter the link into your browser.

The full manual is available for immediate download.

<https://www.ebooklibonline.com>

KOBELCO

Book Code No.

S5 **YT01** 02E

SHOP MANUAL **SK70SR-1E** **YT01**

PRELIMINARY REMARKS

TABLE OF CONTENTS

- 1. GENERAL PRECAUTIONS FOR REPAIRS 1-1
- 2. INTERNATIONAL UNIT CONVERSION SYSTEM 1-4

KOBELCO CONSTRUCTION MACHINERY CO., LTD.

1. GENERAL PRECAUTIONS FOR REPAIRS



1.1 PREPARATION BEFORE DISASSEMBLING

- (1) Understanding operating procedure
Read OPERATION & MAINTENANCE MANUAL carefully to understand the operating procedure.
- (2) Cleaning machines
Remove soil, mud, and dust from the machine before carrying it into the service shop to prevent loss of work efficiency, damage of parts, and difficulty in rust prevention and dust protection while reassembling.
- (3) Inspecting machines
Identify the parts to be disassembled before starting work, determine the disassembling procedure by yourself considering the workshop situations etc., and request procurement of necessary parts in advance.
- (4) Recording
Record the following items for communication and prevention of recurring malfunction.
 - 1) Inspection date and place
 - 2) Model name, applicable machine number, and hour meter read
 - 3) Trouble condition, location and cause.
 - 4) Visible Oil leakage, water leakage and damage
 - 5) Clogging of filters, oil level, oil quality, oil contamination and loosening of connections
 - 6) Result of consideration if any problem exists based on the operation rate per month calculated from hour meter indication after the last inspection date.
- (5) Arrangement and cleaning in service shop
 - 1) Tools required for repair work.
 - 2) Prepare space to place the disassembled parts.
 - 3) Prepare oil containers for spilling oil etc.



1.2 SAFETY IN DISASSEMBLING AND ASSEMBLING

- 1) Wear appropriate clothes with long sleeves, safety shoes, safety helmet and protective glasses.
- 2) Suspend warning tag "DO NOT OPERATE" from the doorknob or the operating lever, and have a preliminary meeting before starting work.
- 3) Stop the engine before starting inspection and maintenance to prevent the operator being

caught in machine.

- 4) Identify the location of a first-aid kit and a fire extinguisher, and also where to make contact in a state of emergency.
- 5) Choose a hard, level and safe place, and place the attachment on the ground securely.
- 6) Use a lifter such as a crane to remove heavy parts (20 kg [45 lbs] or more) from the machine.
- 7) Use proper tools, and replace or repair defective tools.
- 8) Support the machine and attachment with supports or blocks if the work is performed in the lifted condition.

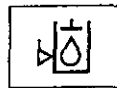

1.3 DISASSEMBLING AND ASSEMBLING HYDRAULIC EQUIPMENT

- (1) Removing hydraulic equipment
 - 1) Before disconnecting pipes, release the hydraulic pressure of the system, or open the return side cover and take out the filter.
 - 2) Carefully drain oil of the removed pipes into a containers without spilling on the floor.
 - 3) Apply plugs or caps on the pipe ends to avoid oil spillage and dust intrusion.
 - 4) Clean off the external surface of the equipment before disassembling, and drain hydraulic and gear oil before placing it on the workbench.
- (2) Disassembling hydraulic equipment
 - 1) Do not disassemble, reassemble or modify the hydraulic equipment without the permission of the manufacturer, who is not responsible for the performance and function of the product after reassembling.
 - 2) When disassembling and reassembling for unavoidable reason, refer the work to qualified personnel who have the specific knowledge or completed the parts service training.
 - 3) Provide matching marks to facilitate reassembling work.
 - 4) Before starting the work, read the manual of disassembling procedure, if it is provided, and decide whether the work can be performed by yourself.
 - 5) Use the special jig and tools without fail if they are specified.
 - 6) If it is hard to remove a part according to the procedure, do not try it by force but investigate the cause.

- 7) Place the removed parts in order and attach tags to facilitate the reassembling.
- 8) Note the location and quantity of parts commonly applied to multiple locations.

(3) Inspecting parts

- 1) Ensure that the disassembled parts are free from seizure, interference and uneven contact.
- 2) Measure and record wear condition of parts and clearance.
- 3) If the problem is found in a part, repair or replace it with a new one.

(4) Reassembling hydraulic equipment

- 1) Turn ON the ventilation fan or open windows to maintain good ventilation prior to starting the cleaning of parts.
- 2) Perform rough and finish cleaning before assembling.
- 3) Remove washing oil by air and apply clean hydraulic or gear oil for assembling.
- 4) Always replace the removed O-rings, backup rings and oil seals with new ones by applying grease in advance.
- 5) Remove dirt and moisture from and perform degreasing on the surface where liquid gasket to be applied.
- 6) Remove rust preventive agent from the new parts before use.
- 7) Fit bearings, bushings and oil seals using special jigs.
- 8) Assemble the parts utilizing matching marks.
- 9) Ensure all the parts are completely assembled after the work.

(5) Installing hydraulic equipment

- 1) Ensure hydraulic oil and lubricant are properly supplied.
- 2) Perform air releasing when:
 - a. Hydraulic oil changed
 - b. Parts of suction side piping replaced
 - c. Hydraulic pump installed
 - d. Slewing motor installed
 - e. Travel motor installed
 - f. Hydraulic cylinder installed

! • Operation of the hydraulic equipment without filling hydraulic oil or lubricant or without performing air releasing will result in damage to the equipment.

- 3) Perform air releasing after loosening the upper drain plug, starting the engine and keep it in

low idle condition. Complete the air releasing when seeping of hydraulic oil is recognized, and tightly plug.

- 4) Perform air releasing of the travel motor and the hydraulic cylinders by running the engine for more than 5 minutes at low speed without load.

! • Do not allow the hydraulic cylinder to bottom on the stroke end just after the maintenance.

- 5) Perform air releasing of pilot line by performing a series of digging, slewing and travel.
- 6) Check hydraulic oil level after placing the attachment to the oil check position, and replenish oil if necessary.

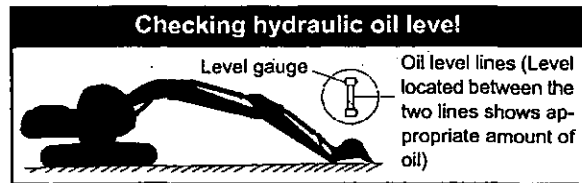

1.4 ELECTRICAL EQUIPMENT

- (1) Do not disassemble electrical equipment.
- (2) Handle it carefully not to drop and give a shock.
- (3) Turn the key OFF prior to connecting and disconnecting work.
- (4) Disconnect the connector by holding it and pressing the lock. Do not pull the wire to apply force to the caulking portion.
- (5) Connect the connector and ensure it is completely locked.
- (6) Turn the key OFF prior to touching the terminal of starter or generator.
- (7) Remove the ground (earth) terminal of battery when handling tools around the battery or its relay.
- (8) Do not splash water on the electrical equipment and connectors during machine washing.
- (9) Check for moisture adhesion inside the waterproof connector after pulling it out, since it is hard to remove moisture from the connector. If moisture adhesion is found, dry it completely before the connection.



- Battery electrolyte is hazardous. Battery electrolyte is dilute sulfuric acid. Exposure of skin or eyes to this liquid will cause burning or loss of eyesight. If the exposure occurs, take the following emergency measures and seek the advice of a medical specialist.

- When skin exposed: Wash with water and soap sufficiently.
- When eyes exposed: Immediately wash away with city water continuously for more than 10 minutes.
- When a large amount of the liquid flows out: Neutralize with sodium bicarbonate or wash away with city water.
- When swallowed: Drink a large amount of milk or water.
- When clothes exposed: Immediately undress and wash.



1.5 HYDRAULIC PARTS

- 1) O-ring
 - Ensure O-rings have elasticity and are not damaged before use.
 - Use the appropriate O-rings. O-rings are made of various kinds of materials having different hardness to apply to a variety of parts, such as the part for moving or fixed portion, subjected to high pressure, and exposed to corrosive fluid, even if the size is same.
 - *Fit the O-rings without distortion and bend.*
 - Always handle floating seals as a pair.
- 2) Flexible hose (F hose)
 - Use the appropriate parts. Different parts are used depending on the working pressure even the size of fitting and the total length of the hose is same.
 - Tighten the fitting at the specified torque. Ensure no kink, tension, interference nor oil leakage is recognized.

1.6 WELDING REPAIR

- (1) Refer repair welding to qualified personnel according to the appropriate procedure.
- (2) Disconnect the ground (earth) cable of the battery before starting the repair. Failure to do so will cause damage to the electrical equipment.
- (3) Move away the articles in advance that may cause fire if exposed to sparks.

- (4) Before starting the repair of the attachment, do not fail to cover the plated surface of the piston rod with flameproof sheet to prevent it from being exposed to sparks.

1.7 ENVIRONMENTAL MEASURE

- (1) Run the engine at the place that is sufficiently ventilated.
- (2) Industrial waste disposal
Dispose of the following parts according to the relevant regulations:
Waste oil and waste container
Battery
- (3) Precautions for handling hydraulic oil
Exposure of eyes to hydraulic oil will cause inflammation. Wear protective glasses before handling to avoid an accident. If an eye is exposed to the oil, take the following emergency measures:
 - When an eye exposed: Immediately wash away with city water sufficiently till stimulative feeling vanishes.
 - When swallowed: Do not let vomit, and receive medical treatment immediately.
 - When skin exposed: Wash with water and soap sufficiently.
- (4) Others
Use replacement parts and lubricants

2. INTERNATIONAL UNIT CONVERSION SYSTEM

(Based on MARKS' STANDARD HANDBOOK FOR MECHANICAL ENGINEERS)

Introduction

Although this manual uses the JIS unit system, if you need SI unit, refer to the following international system of units.

Given hereinafter is an excerpt of the units that are related to this manual :

1. Etymology of SI Units

French: Le Système International d' Unités
English: International System of Units

2. Construction of SI Unit System

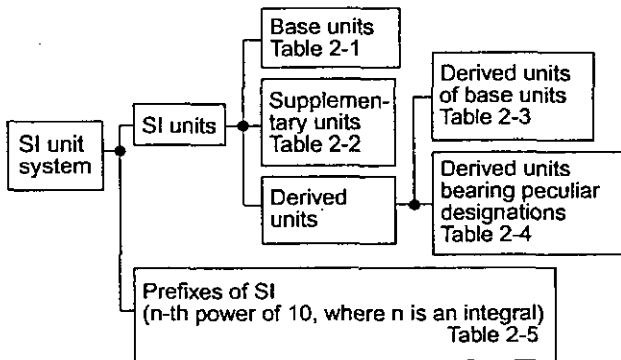

(4) Derived Units bearing Peculiar Designations [Table 2-4]

QUANTITY	UNIT	SYMBOL	FORMULA
Frequency	Hertz	Hz	1/s
Force	Newton	N	kg·m/s ²
Pressure and Stress	Pascal	Pa	N/m ²
Energy, Work and Quantity of heat	Joule	J	N·m
Power	Watt	W	J/s
Quantity of electricity	Coulomb	C	A·s
Electric potential difference, Voltage, and Electromotive force	Volt	V	W/A
Quantity of static electricity and Electric capacitance	Farad	F	C/V
Electric resistance	Ohm	Ω	V/A
Celcius temperature	Celcius degree or degree	°C	(t+273.15)K
Illuminance	Lux	lx	lm/m ²

(1) Base Units [Table 2-1]

QUANTITY	UNIT	SYMBOL
Length	metre	m
Mass	kilogram	kg
Time	second	s
Electric current	ampere	A
Thermodynamic temperature	kelvin	K
Amount of substance	mol	mol
Luminous intensity	candela	cd

(5) Prefixes of SI [Table 2-5]

PREFIX	SYMBOL	MULTIPLICATION FACTORS
Giga	G	10 ⁹
Mega	M	10 ⁶
Kilo	k	10 ³
Hecto	h	10 ²
Deca	da	10
Deci	d	10 ⁻¹
Centi	c	10 ⁻²
Milli	m	10 ⁻³
Micro	μ	10 ⁻⁶
Nano	n	10 ⁻⁹
Pico	p	10 ⁻¹²

(2) Supplementary Units [Table 2-2]

QUANTITY	UNIT	SYMBOL
Plane angle	radian	rad
Solid angle	steradian	sr

(3) Derived Units [Table 2-3]

QUANTITY	UNIT	SYMBOL
Area	square metre	m ²
Volume	cubic metre	m ³
Velocity	metre per second	m/s
Acceleration	metre per second squared	m/s ²
Density	kilogram per cubic metre	kg/m ³

(6) Unit Conversion [Table 2-6]

QUANTITY	JIS	SI	CONVERSION FACTOR
Weight	kgf	—	
Mass	—	kg	
Force	kgf	N	1 kgf=9.807 N
Torque	kgf·m	N·m	1 kgf·m=9.807 N·m
Pressure	kgf/cm ²	MPa	1 kgf/cm ² =0.09807 MPa
Motive power	PS	kW	1 PS=0.7355 kW
Revolution	rpm	min ⁻¹	r/min *1

*1 Units that are allowed to use

NOTES

NOTES

KOBELCO

Book Code No.

S5 YT02_{02E}

SHOP MANUAL SK70SR-1E **YT02**

— SPECIFICATIONS —

TABLE OF CONTENTS

1. NAME OF COMPONENTS	1-1
2. MACHINE DIMENSIONS	1-2
3. WEIGHT OF COMPONENTS	1-3
4. TRANSPORTATION DIMENSION & WEIGHT	1-4
5. SPECIFICATIONS & PERFORMANCE	1-7
6. TYPE OF CRAWLER	1-8
7. TYPE OF BUCKET	1-9
8. COMBINATIONS OF ATTACHMENT	1-10
9. ENGINE SPECIFICATION	1-11

KOBELCO CONSTRUCTION MACHINERY CO., LTD.

1. NAME OF COMPONENTS

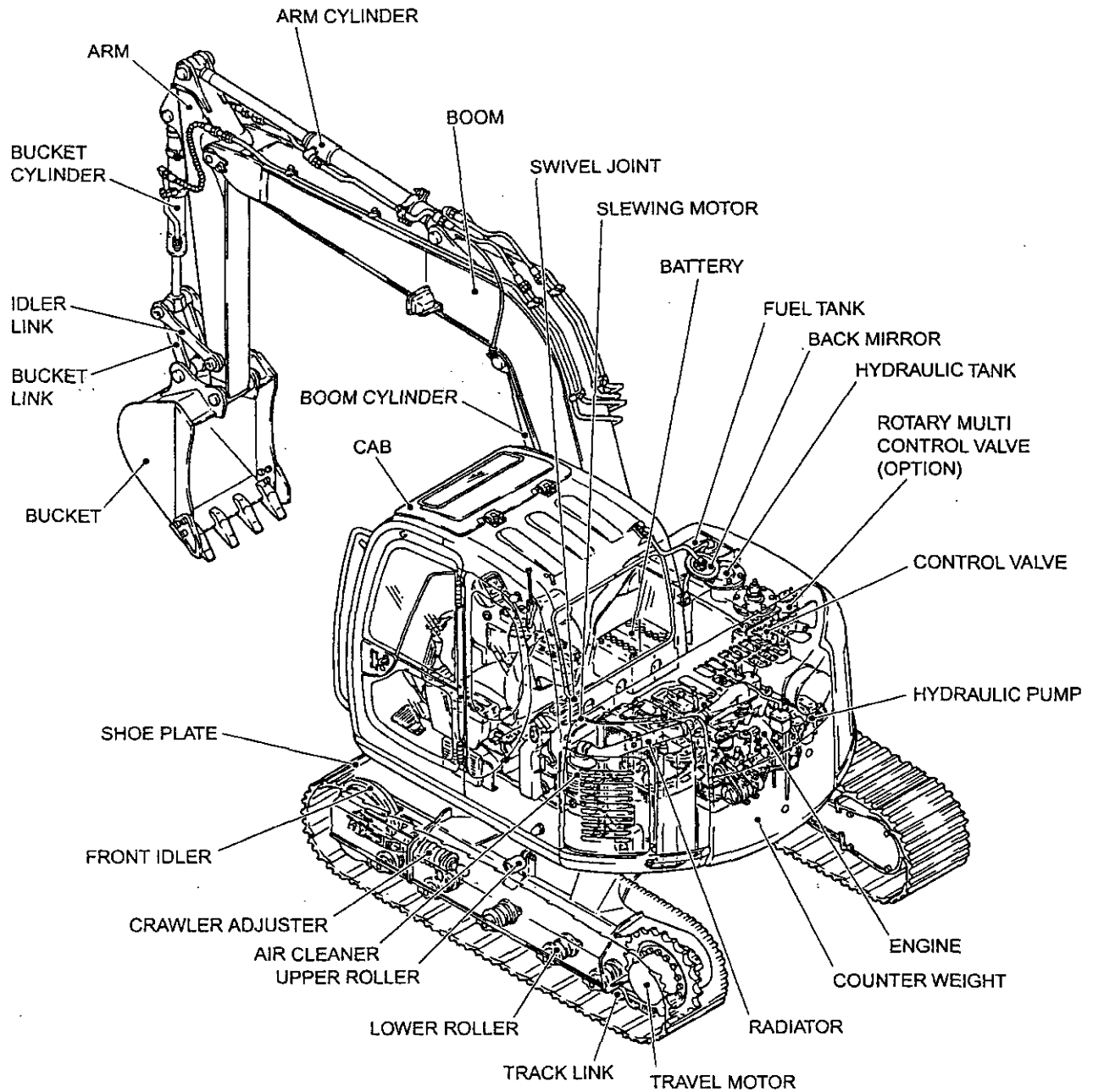

2. MACHINE DIMENSIONS

2.1 2.07 M (6 ft-9 in) ARM

Unit : mm (ft-in)

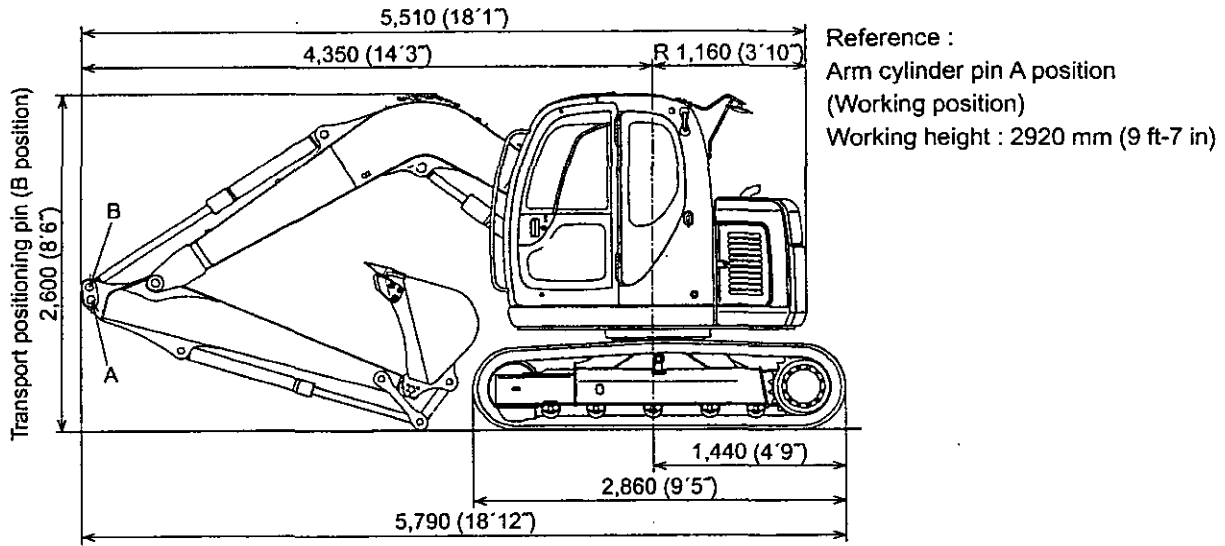

2.2 1.65 M (5 ft-5 in) ARM

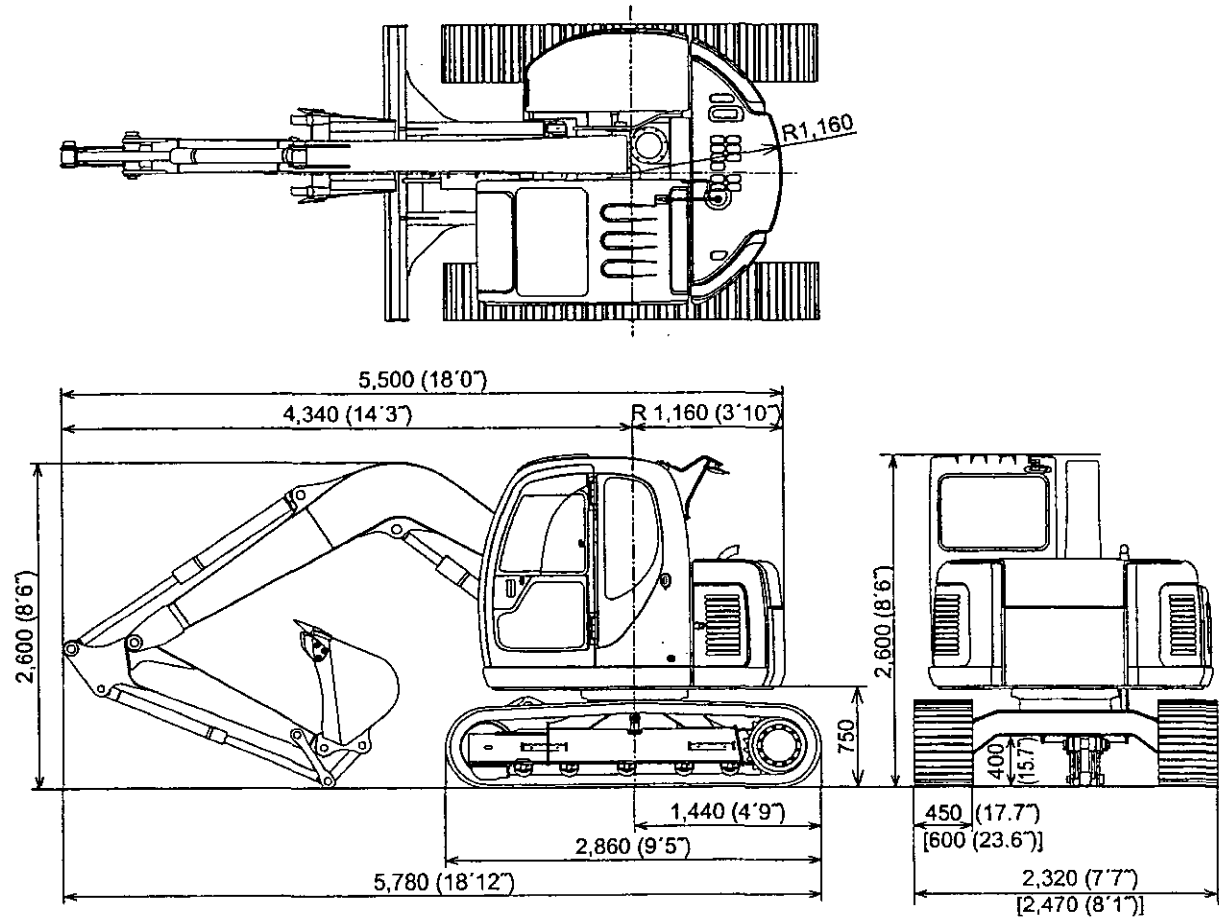

3. WEIGHT OF COMPONENTS

		Unit : kg (lbs)	
Item	Model	2.07 M (6 ft-9 in) Arm +600 mm (23.6 in shoe)	1.65 M (5 ft-5 in) Arm +450 mm (17.7 in shoe)
Machine complete		7,180 (15,830)	6,940 (15,300)
1. Upper frame assy (including the following :)		3,250 (7,160)	←
1.1 Counterweight		820 (1,810)	←
Counterweight (Add-on)		400 (880)	←
1.2 Cab		210 (460)	←
1.3 Engine		* 250 (550)	←
1.4 Hydraulic oil tank		* 64 (140)	←
1.5 Fuel tank		* 53 (120)	←
1.6 Slewing motor (including reduction unit)		67 (150)	←
1.7 Control valve		42(93)	←
1.8 Boom cylinder		* 92 (200)	←
1.9 Pin (2pcs. for mounting boom)		14 (31)	←
1.10 Pump		41 (90)	←
1.11 Radiator		* 44 (97)	←
		Including 125 kg (276 lbs) of grease, water, etc	
2. Lower frame assy (including the following :)		2,590 (5,710)	2,370 (5,230)
2.1 Slewing bearing		115 (250)	←
2.2 Travel motor (including reduction unit)		90 (200) X 2	←
2.3 Upper roller		4 (9) X 2	←
2.4 Lower roller		15 (33) X10	←
2.5 Front idler		44 (97) X 2	←
2.6 Track tension adjuster		28 (62) X 2	←
2.7 Sprocket		27 (59) X 2	←
2.8 Swivel joint		21 (46)	←
2.9 Track link with 450 mm (17.7 in) shoes assy		420 (926) X 2	←
Track link with 600 mm (23.6 in) shoes assy		530 (1,170) X 2	←
Track link with 600 mm (23.6 in) triangle shoes assy		470 (1,040) X 2	←
2.9.1 Track link assy		155 (340) X2	←
3. Attachment			←
{3.72 m (12 ft-2 in) Boom+2.07 m (6 ft-9 in) Arm+0.22 m ³ (0.28 cu-yd) Bucket}		1,110 (2,450)	←
{3.72 m (12 ft-2 in) Boom+1.65 m (5 ft-5 in) Arm+0.28 m ³ (0.37 uc-yd) Bucket}		—	1,080 (2,380)
3.1 Bucket assy		190 (420)	200 (440)
3.2 Arm assy (including the following :)		290 (640)	250 (550)
3.2.1 Arm		180 (400)	130 (290)
3.2.2 Bucket cylinder		44 (97)	←
3.2.3 Idler link		6 (13) X 2	←
3.2.4 Bucket link		8 (17) X 2	←
3.2.5 Pin (2 pcs. for mounting bucket cylinder / 2 pcs. for mounting bucket)		* 17 (37)	←
3.3 Boom assy (including the following :)		630 (1,390)	←
3.3.1 Boom		390 (860)	←
3.3.2 Arm cylinder		72 (160)	←
3.3.3 Pin (Mounting arm · Mounting arm cylinder)		16 (35)	←
4. Lubricant and water (including the following :)		130 (290)	←
4.1 Hydraulic oil		* 49 (108)	←
4.2 Engine oil		5 (11)	←
4.3 Fuel		71 (157)	←
4.4 Water		5 (11)	←

Note : Numerical values marked * indicate the dry weight.

4. TRNSPORTATION DIMENSION AND WEIGHT

■ OVERALL DIMENSIONS OF MACHINE ON A TRAILER

● OVERALL DIMENSIONS OF A COMPLETE MACHINE ON A TRAILER

Item	Type	2.07 M (6 ft-9 in) Arm + 600 mm (23.6 in) shoes	1.65 M (5 ft-5 in) Arm + 450 mm (17.7 in) shoes
Width	m (ft-in)	2,470 (8'1")	2,320 (7'7")
Weight	kg (lb)	7,180 (15,830)	6,940 (15,300)

Specification :

- The parenthesis shows 2.07m arm model.
- Regarding 2.07m arm machine, put the arm cylinder rod in a transport position (B) by referring to the outside dimensions on page 2

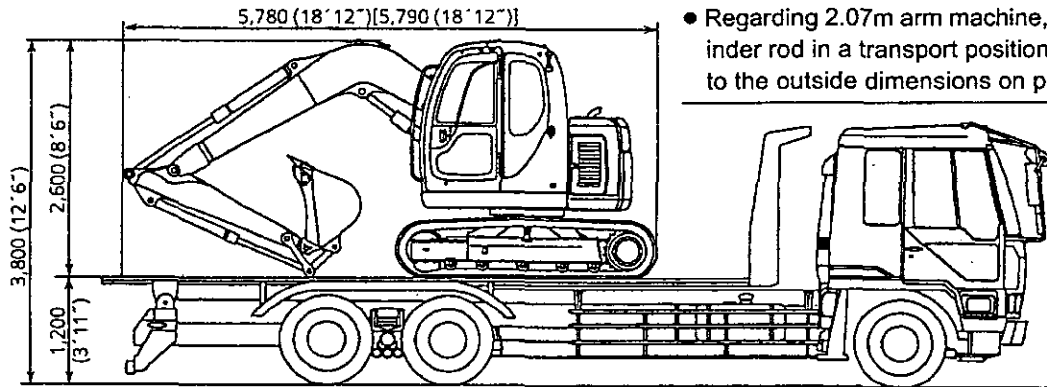

● OVERALL DIMENSIONS OF WITHOUT ARM AND CUCKET

Combination	Type	A : Shoe width mm (ft-in)	L : Length mm (ft-in)	H : Height mm (ft-in)	W : Width mm (ft-in)	Weight mm (ft-in)
Without arm and bucket		600 (23.6")	5,670 (18'7")	2,600 (8'6")	2,470 (8'1")	6,700 (14,770)
		450 (17.7")	5,670 (18'7")	2,600 (8'6")	2,320 (7'7")	6,490 (14,310)

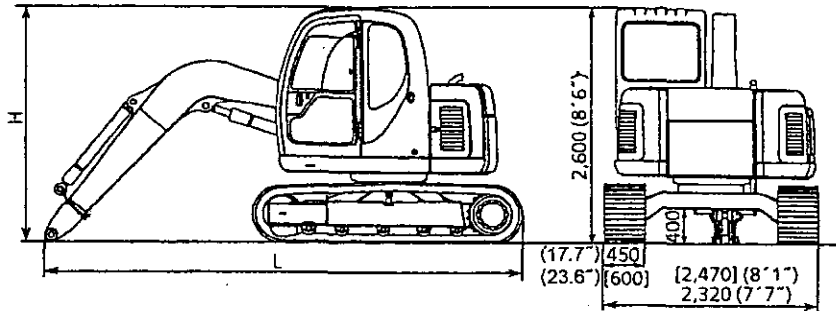

● OVERALL DIMENSIONS OF WITHOUT BOOM, ARM AND BUCKET

Combination	Type	A : Shoe width mm (ft-in)	L : Length mm (ft-in)	H : Height mm (ft-in)	W : Width mm (ft-in)	Weight mm (ft-in)
Without boom, arm and bucket		600 (23.6")	2,860 (9'5")	2,600 (8'6")	2,470 (8'1")	6,070 (13,380)
		450 (17.7")	2,860 (9'5")	2,600 (8'6")	2,320 (7'7")	5,860 (12,920)

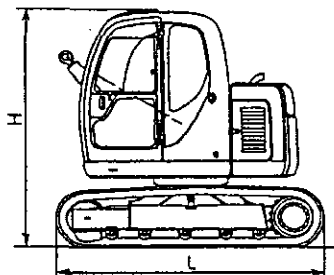

• OVERALL DIMENSIONS OF BOOM

Item	Type	3.72 m (12 ft-2 in) Boom
Length X Height X Width L X H X W	m (ft-in)	3.86 X 1.43 X 0.36 (12'8" X 4'8" X 1'2")
Weight	kg (lb)	500 (1,100)

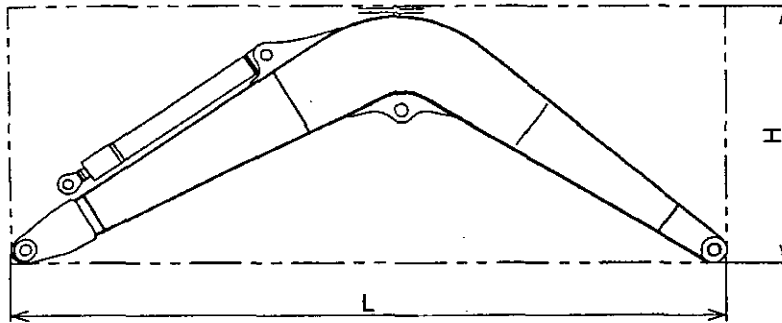

• OVERALL DIMENSIONS OF ARM + BUCKET

Item	Type	1.65 m (5 ft-5 in) Arm + 0.28 m ³ (0.37 cu-yd) Bucket	2.07 m (6 ft-9 in) Arm + 0.22 m ³ (0.29 cu-yd) Bucket
Length X Height X Width L X H X W	m (ft-in)	3.14 X 0.70 X 0.75 (10'4" X 2'4" X 2'6")	3.61 X 0.71 X 0.65 (11'10" X 2'2.4" X 2'2")
Weight	kg (lb)	450 (990)	480 (1,060)

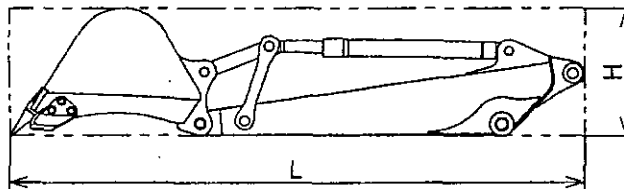

• OVERALL DIMENSIONS OF ARM

Item	Type	1.65 m (5 ft-5 in) Arm	2.07 m (6 ft-9 in) Arm
Length X Height X Width L X H X W	m (ft-in)	2.17 X 0.53 X 0.36 (7'1" X 1'9" X 1'2")	2.64 X 0.53 X 0.36 (8'8" X 1'9" X 1'2")
Weight	kg (lb)	250 (550)	290 (640)

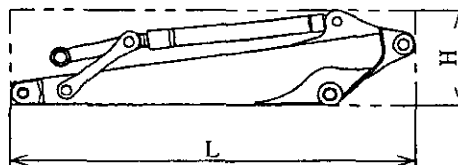

• OVERALL DIMENSIONS OF BUCKET

Type	Hoe bucket			
Length X Height X Width L X H X W m (ft-in)	1.10 X 0.60 X 0.40 (3'7" X 1'12" X 1'4")	0.98 X 0.89 X 0.48 (3'3" X 2'11" X 1'7")	0.98 X 0.89 X 0.55 (3'3" X 2'11" X 1'10")	0.98 X 0.89 X 0.65 (3'3" X 2'11" X 2'2")
Weight kg (lbs)	150 (330)	150 (330)	170 (380)	190 (420)
Bucket capacity m ³ (cu-yd)	0.11 (0.14)	0.14 (0.18)	0.18 (0.23)	0.22 (0.29)

Type	Hoe bucket		V-bucket	Slope finishing bucket
Length X Height X Width L X H X W m (ft-in)	0.98 X 0.89 X 0.75 (3'3" X 2'11" X 2'6")	0.98 X 0.89 X 0.85 (3'3" X 2'11" X 2'9")	1.08 X 0.47 X 1.41 (3'6" X 1'6" X 4'7")	0.79 X 0.62 X 1.50 (2'7" X 2'0" X 4'11")
Weight kg (lbs)	200 (440)	220 (490)	180 (340)	300 (660)
Bucket capacity m ³ (cu-yd)	0.28 (0.37) STD	0.35 (0.45)	0.24 (0.31)	0.26 (0.34)

• Hoe bucket

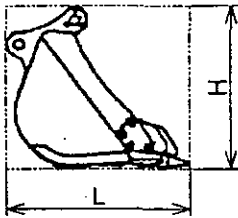

• V-bucket

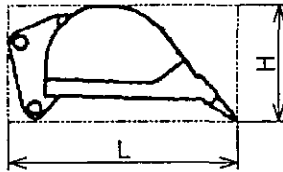

• Slope finishing bucket

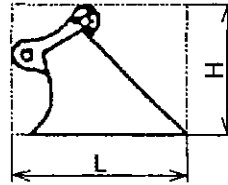

5. SPECIFICATIONS AND PERFORMANCE

5.1 SPEED AND CLIMBING CAPABILITY

Model & Shoe spec.		SK70SR-1E	
		Iron shoe	Rubber shoe
Item			
Swing speed		12.5 {12.5}	
Travel speed	km/h	3.1 / 5.3	3.2 / 5.3
Gradeability	% (degree)	70 (35)	

5.2 ENGINE

Engine model	ISUZU CC-4JG1
Type	Water-cooled 4-cycle direct injection type engine
Number of cylinders-Bore X Stroke	4-95.4 mm X 107 mm (3.76 in X 4.21 in)
Total displacement	3,059 cc (187 cu-in)
Rated output / Rotation speed	55 PS / 2,100 rpm
Maximum torque / Rotation speed	19.1 kgf-m (139 ft-lbs) / 1,800 rpm
Starter	24 V / 3.2 kW
Alternator	24 V / 30A

5.3 HYDRAULIC COMPONENTS





Hydraulic pump	Variable displacement axial piston+gear pump
Hydraulic motor (Swing)	Axial piston motor
Hydraulic motor (Travel)	2-speed axial piston motor
Control valve	6-spool control valve
Cylinder (Boom, arm, and Bucket)	Double action cylinder
Oil cooler	Air-cooled type

5.4 WEIGHT

Unit : kg (lbs)

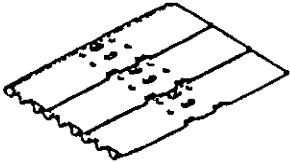
Fully equipped weight	6,940 (15,300)	7,180 (15,830)
Upper structure	3,250 (7,170)	←
Lower machinery (With 600 mm (23.6 in) grouser shoe) (With 450 mm (17.7 in) grouser shoe)	2,370 (5,230)	— 2,590 (5,710)
Attachment [Boom+2.07 m (6 ft-9 in) Arm +0.22 m ³ (0.29 cu-yd) bucket]	1,080 (2,380)	—
[Boom+1.65 m (5 ft-5 in) Arm +0.28 m ³ (0.37 cu-yd) bucket]	—	1,110 (2,450)

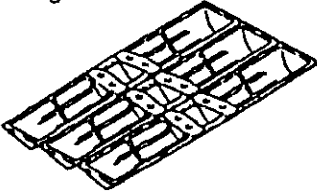
6. TYPE OF CRAWLER

Shape	Shoe width mm (in)	Overall width of crawler mm (in)	Ground pressure kgf/cm ² (psi)
Iron crawler  39 links	450 (17.7)	2,320 (7'7")	0.32 (4.5)
	600 (23.6)	2,470 (8'1")	0.24 (3.4)
Flat shoe  39 links	450 (17.7)	2,320 (7'7")	0.33 (4.6)
Triangle shoe  39 links	600 (23.6)	2,470 (8'1")	0.23 (3.3)
	700 (27.6)	2,570 (8'5")	0.20 (2.9)
Rubber crawler 	450 (17.7)	2,320 (7'7")	0.32 (4.5)

Note :

Use grouser shoes 600 mm (23.6 in) or 450 mm (17.7 in) on rough ground (areas covered with rocks and gravel). If you drive or excavate with other shoes, this may cause shoe bending, shoe bolt looseness, and track assembly (link, roller, etc.) damage.



Suggest:

For more complete manuals. Please go to the home page.

<https://www.ebooklibonline.com>

If the above button click is invalid. Please download this document first, and then click the above link to download the complete manual.

Thank you so much for reading

7. TYPE OF BUCKET

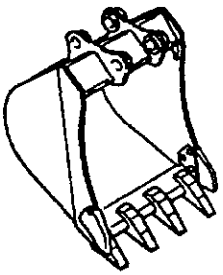
Hoe bucket	Heaped capacity m ³ (cu-yd)	Struck m ³ (cu-yd)	Outer width mm (ft-in)		Number of tooth	W or W/O side cutter	Availability of face shovel	Weight kg (lbs)
			With side cutter	Without side cutter				
	0.11 (0.14)	0.09 (0.12)	—	400 (1'4")	3	No	Yes	150 (330)
	0.14 (0.18)	0.12 (0.16)	480 (1'6")	—	3	Yes (welded)	Yes	160 (350)
	0.18 (0.24)	0.14 (0.18)	550 (1'10")	480 (1'7")	3	Yes	Yes	170 (380)
	0.22 (0.29)	0.18 (0.24)	650 (2'2")	580 (1'11")	4	Yes	Yes	190 (420)
	STD 0.28 (0.37)	0.22 (0.29)	750 (2'6")	680 (2'3")	4	Yes	Yes	200 (440)
	0.35 (0.46)	0.26 (0.34)	850 (2'9")	780 (2'7")	4	Yes	Yes	220 (640)

V-shape bucket

Capacity : 0.24 m³
(0.31 cu-yd)

Weight : 180 kg (400 lbs)
Face shovel unavailable

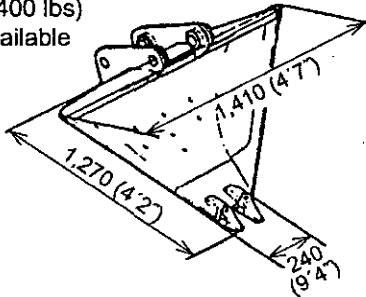

Slope finishing bucket

Capacity : 0.26 m³
(0.34 cu-yd)

Weight : 300 kg (660 lbs)
Face shovel unavailable

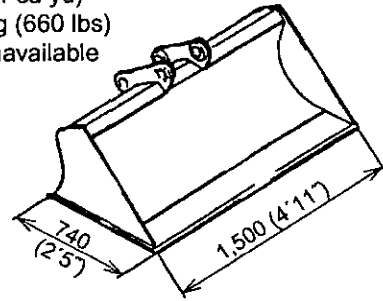



8. COMBINATIONS OF ATTACHMENT

Type	Bucket		Applicable Arm		
	Heaped capacity m ³ (cu-yd)	Struck m ³ (cu-yd)	1.65 m (5 ft-5 in) Arm	2.07 m (6 ft-9 in) Arm	1.65 m (5 ft-5 in) Arm+ Extension Arm
Hoe bucket	0.11 (0.14)	0.09 (0.12)	○	○	○
	0.14 (0.18)	0.12 (0.16)	○	○	○
	0.18 (0.24)	0.14 (0.18)	○	○	○
	0.22 (0.29)	0.18 (0.24)	○	◎	◎
	0.28 (0.37)	0.22 (0.29)	◎	△	△
	0.35 (0.46)	0.26 (0.34)	△	×	×
V-bucket	0.24 (0.31)	0.16 (0.21)	△	△	△
Slope finishing bucket	0.26 (0.34)	0.14 (0.18)	△	△	△
Breaker	—	—	○	○ (Reinforced arm)	×
Nibbler	—	—	○ (Reinforced arm)	○ (Reinforced arm)	×

Note :

- ◎ Standard combination
- General operation : Excavation or loading of sand, gravel, and clay
- △ Light operation : Mainly loading or loose gravel (e.g., cultivation or loading of sand or gravel)
- × Prohibited combination : There are problems from the view points of strength and stability.

- Use the attachments recommended by KOBELCO. Reinforcement of arm allows to use it as nibbler and breaker.
The trouble due to the use in the condition "Use not allowed" described in the above table is not included in our responsibility
- When bucket marked by △ has been attached or nibbler has been attached on long arm, the specified stability may not be obtained. So add weight 400 kg (880 lbs) in add-on type as required.

	CAUTION	
If any other bucket, except for the backhoe bucket, is turned over and used for excavation, damage to the arm and bucket may occur.		

<https://www.ebooklibonline.com>

Hello dear friend!

Thank you very much for reading.

Enter the link into your browser.

The full manual is available for immediate download.

<https://www.ebooklibonline.com>