

KOBELCO

SHOP MANUAL

HYDRAULIC EXCAVATOR

SK70SR

Applicable: YT00101~

S5YT0001E

07/03

HYDRAULIC EXCAVATOR

**SHOP
MANUAL**

model **SK70SR**

INDEX

1	SPECIFICATION SECTION
2	MAINTENANCE SECTION
3	SYSTEM SECTION
4	DISASSEMBLY SECTION
5	TROUBLESHOOTING
6	ENGINE SECTION
7	INSTALLATION PROCEDURES FOR OPTIONAL ATTACHMENT

MAINTENANCE SPECIFICATION

SYSTEM

DISASSEMBLING

E/G TROUBLESHOOTING

E/G

KOBELCO

Book code No. S5YT0001E①

Book Code No. Distribution Year - Month		Index No.	Title	
S5YT0101E 1998-07		MAINTENANCE SPECIFICATION	OUTLINE	YT01
S5YT0201E 1998-07			SPECIFICATION	YT02
S5YT0301E 1998-07			ATTACHMENT DIMENSION	YT03
S5YT1101E 1998-07		MAINTENANCE SPECIFICATION	TOOLS	YT11
S5YT1201E 1998-07			STANDARD MAINTENANCE TIME SCHEDULE	YT12
S5YT1301E 1998-07			MAINTENANCE STANDARD AND TEST PROCEDURE	YT13
S5YT2101E 1998-07		SYSTEM	MECHATRO CONTROL SYSTEM	YT21
S5YT2201E 1998-07			HYDRAULIC SYSTEM	YT22
S5YT2301E 1998-07			ELECTRICAL SYSTEM	YT23
S5YT2401E 1998-07			COMPONENTS SYSTEM	YT24
S5YT2501E 1998-07			AIR-CONDITIONER SYSTEM	YT25
—			—	
S5YT3101E 1998-07		DISASSEMBLING	DISASSEMBLING AND ASSEMBLING	YT31
S5YT3201E 1998-07			ATTACHMENT	YT32
S5YT3301E 1998-07			UPPER SWING BODY	YT33
S5YT3401E 1998-07			TRAVEL FRAME	YT34
S5YT4101E 1998-07		TROUBLESHOOTING	MECHATRO CONTROL	YT41
S5YT4201E 1998-07			HYDRAULIC	YT42
S5YT4301E 1998-07			ELECTRICAL	YT43
S5YT4401E 1998-07			ENGINE	YT44
S5YT5101E 1998-07		E/G	ENGINE	YT51
S5YT6301E 1999-02		OPT.	MOUNTING THE BREAKER AND NIBBLER & BREAKER	YT63
YT00101~			APPLICABLE MACHINES	

<https://www.ebooklibonline.com>

Hello dear friend!

Thank you very much for reading.

Enter the link into your browser.

The full manual is available for immediate download.

<https://www.ebooklibonline.com>

Book code No. S5 YT01 01E

KOBELCO

SHOP MANUAL SK70SR **YT01**

OUTLINE

TABLE OF CONTENTS

1. GENERAL PRECAUTIONS FOR MAKING REPAIRS	1
2. ESCAPING PROCEDURE IN CASE OF EMERGENCY	4
3. INTERNATIONAL UNIT CONVERSION SYSTEM ...	5

Applicable Machines
YT00101~

Revision	Date of Issue	Remarks
First edition	July, 1998	S5YT0101E K

1. GENERAL PRECAUTIONS FOR MAKING REPAIRS



1.1 PREPARATION BEFORE DISASSEMBLING

- (1) Knowledge of operating procedure
Read Operator's Manual carefully to understand the operating procedure.
- (2) Cleaning machines
Clean machines of soil, mud, and dust before carrying into the repair shop.
Carrying a soiled machine into the repair shop, causes making less efficient work and damage of parts, and interferes with rust prevention and dust protection while reassembling.
- (3) Inspecting machines
Confirm the disassembling section before starting work, determine the disassembly procedure taking the conditions in work shop into account, and request to procure necessary parts in advance.
- (4) Recording
Record the following items to keep contact and prevent malfunction from recurring.
 - 1) Inspecting date, place
 - 2) Model name, Applicable machine No., Records on hour meter
 - 3) Trouble condition, place, cause
 - 4) Visible oil leakage, water leakage and damage
 - 5) Clogging of filters, etc., oil level, oil quality, oil contamination and looseness which can be inspected.
 - 6) Examine the problems on the basis of operation rate with the last inspection date and records on hour meter.
- (5) Arrangement and cleaning in repair shop
 - 1) Tools required for repair work.
 - 2) Specify places to put the disassembled parts on in advance.
 - 3) Prepare oil pans for leaking oil, etc.



1.2 SAFETY WHEN DISASSEMBLING AND ASSEMBLING

- (1) Safety
 - 1) Wear appropriate clothing, safety shoes, safety helmet, goggles, and clothes with long sleeves.
 - 2) Suspend warning tag "Don't operate" from lever, and begin preliminaries before getting down to work.
 - 3) Before starting inspection and maintenance which contain the danger of being caught in machine, stop the engine.

- 4) Confirm the position of first-aid box and fire extinguisher, and also where to make contact for emergency measure and ambulance to prepare for accidents and fire.
- 5) Choose a hard, flat and safe place, and put attachment on the ground without fail.
- 6) Use crane, etc. to remove parts of heavy weight (20kg [44 lbs] or more).
- 7) Use proper tools, and change or repair defective tools.
- 8) Machine and attachment required to work in the lifting condition should be supported with supports or blocks securely.

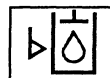

1.3 DISASSEMBLING AND ASSEMBLING HYDRAULIC EQUIPMENT

- (1) Removing hydraulic equipment assy
 - 1) Before removing pipes, release the pressure of hydraulic oil tank, or open the cover on the return side to tank, and take out the filter.
 - 2) Put the oil in the removed pipes in reservoir taking care it is not spilled on the ground.
 - 3) Pipes with plugs, caps, etc. to prevent oil leaking, entry of dust, etc.
 - 4) Clean the outside surface of equipment, etc. before disassembling, and drain hydraulic oil and gear oil before putting them on working bench.
- (2) Disassembling hydraulic equipment
 - 1) Since performance and function of hydraulic equipment after disassembly and assembly results in immunity from responsibility on the manufacture's side, disassembly, assembly and conversion without permission are strictly prohibited.
 - 2) If it is unavoidably necessary to disassemble and convert, it should be carried out by experts or personnel authorized through service training.
 - 3) Make match mark on parts for reassembling.
 - 4) Before disassembling, read Disassembling Instruction supplied with equipment in advance, and determine if the disassembly and assembly are permitted or not.
 - 5) For parts which are required to use jig and tools, don't fail to use the specified jig and tools.
 - 6) For parts which can not be removed in the specified procedure, never force removal. First check for the cause.

- 7) The removed parts should be put in order and tagged so as to install on proper places without confusion.
- 8) For common parts, pay attention to the quantity and places.
- (3) Inspecting parts
 - 1) Check that the disassembled parts are free from adherence, interference and non-uniform working face.
 - 2) Measure the wear of parts and clearance, and record the measured values.
 - 3) If an abnormality is detected, repair or replace the parts.
- (4) Reassembling hydraulic equipment
 - 1) Before cleaning, turn the fan on or open doors to ventilate air.
 - 2) Before assembly, clean parts roughly first, and then completely.
 - 3) Remove with oil by compressed air, and apply hydraulic oil or gear oil, and then assemble them.
 - 4) Replace the removed O ring, back-up rings and oil seal with new ones, and apply grease oil on them before assembling.
 - 5) Removes stain and water on the surface on which liquid sealant are applied, decrease them, and apply liquid sealant on them.
 - 6) Before assembling, remove rust preventives on new parts.
 - 7) Use special tools to fit bearings, bushing and oil seal.
 - 8) Assemble parts matching to the marks.
 - 9) After completion, check that there is no omission of parts.
- (5) Installing hydraulic equipment
 - 1) Confirm hydraulic oil and lubrication oil.
 - 2) Air release is required in the following cases ;
 - a. Change of hydraulic oil
 - b. Replacement of parts on suction pipe side
 - c. Hydraulic pump
 - d. Swing motor
 - e. Travel motor
 - f. Hydraulic cylinder

! If hydraulic oil and lubricating oil are not filled and also air bleed is not performed, the hydraulic equipment may be damaged.

- 3) For air bleed of hydraulic pump and swing motor, loosen drain plug on the upper part, start engine, and run in low idling, then bleed air until hydraulic oil is oozed out. After completion of air bleed, tighten plug securely.
- 4) For air bleed of travel motor and hydraulic cylinder, starts engine and operate it for 10 minutes or more at no-load and low speed.

! For cylinder, don't move it to the stroke end at beginning.

- 5) Air in pilot circuit can be bled out by only operating digging, swing and traveling motions thoroughly.
- 6) Check hydraulic oil level.
Move attachments to hydraulic oil check position, and check hydraulic oil level of tank. Refill oil if the oil level is lower than the minimum level.

How to check oil level of hydraulic oil tank

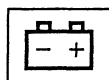
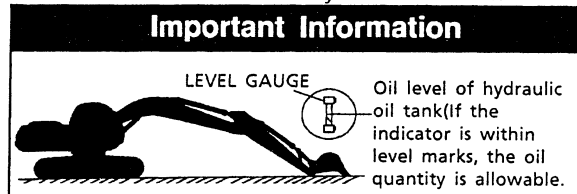

1.4 ELECTRICAL EQUIPMENT

- (1) The disassembly of electrical equipment is not allowed.
- (2) Handle equipment with care so as not to drop it or bump it.
- (3) Connector should be removed by unlocking while holding the connector.
Never stress in tension to the caulked section by pulling wire.
- (4) Check that connector is connected and locked completely.
- (5) Switch key off before removing and connecting connector
- (6) Switch key off before touching terminals of starter and alternator.
- (7) Remove battery grounding terminal before beginning work close to battery and battery relay with tools.
- (8) Wash machine with care so as not to splash water on electrical equipment and connector.

- (9) When water has entered in the waterproofed connector, the removing of water is not easy. So check the removed waterproofed connector with care to protect it from entry of water. If moisture adheres on it, dry it completely before connecting.



Battery electrolyte is dangerous. The battery electrolyte is dilute sulfuric acid, and causes scald and loss of eyesight by adhering on eyes, skin and clothes. When the electrolyte has adhered on them, take an emergency measure immediately and see a doctor for medical advice.

- When it has adhered on skin;
Wash with soap and water.
- When it has got in eyes;
Wash in water for 10 minutes or more immediately.
- When it has spilled out in large quantity;
Use sodium bicarbonate to neutralize, or wash away with water.
- When it was swallowed;
Drink milk or water.
- When it has adhered on clothes;
Wash it immediately.

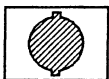

1.5 HYDRAULIC PARTS

1) O ring

- Check that O ring is free from flaw and has elasticity before fitting.
- Even if the size of O ring is equal, the usage differs, for example in dynamic and static sections, the rubber hardness also differs according to the pressure force, and also the quality differs depending on the materials to be seated. So, choose proper O ring.
- Fit O ring so as to be free from distortion and bend.
- Floating seal should be put in pairs.

2) Flexible hose (F hose)

- Even if the connector and length of hose are the same, the parts differ according to the withstanding pressure. Use proper parts.

- Tighten it to the specified torque, and check that it is free from distortion, over tension, interference, and oil leakage.

1.6 WELD REPAIR

- (1) The weld repair should be carried out by authorized personnel in the specified procedure after disconnecting the grounding cable of battery. If the grounding cable is not disconnected, the electrical equipment may be damaged.
- (2) Remove parts which may cause flame due to the entry of spark beforehand.
- (3) Repair attachments which are damaged, giving particular attention to the plated section of piston rod to protect it from sparks, and don't fail to cover the section with fire clothes.

1.7 ENVIRONMENTAL ISSUES

- (1) Engine should be started and operated in the place where air can be sufficiently ventilated.
- (2) Industrial waste disposal
The following parts follows the regulation.
Waste oil, waste container
Battery
- (3) Asbestos parts
Breathing dust that may be generated when handling components containing asbestos fibers raises danger of getting lung cancer. Don't raise dust by compressed air and breath it.
Parts to be handled with care :
Brake parts, gasket, etc.
- (4) Precautions for handling hydraulic oil
Hydraulic oil may cause inflammation of eyes. Wear goggles to protect eyes on handling it.
 - When it has got in eyes ;
Wash eyes with water until the stimulus is gone.
 - When breathed dust ;
Immediately see a doctor for medical advice.
 - When it has adhered on skin ;
Wash with soap and water.
- (5) Others
For spare parts, grease and oil, use KOBELCO genuine ones.

2. ESCAPING PROCEDURE IN CASE OF EMERGENCY

2.1 WHEN CAB DOOR DOES NOT OPEN ;

- (1) Escape from the front window.
- (2) Escape from skylight.
- (3) When front window and skylight do not open ;
The life hammer is always reserved on the rear left side of cab. Break the glass on the rear side of cab, and escape from there.

⚠ Break the window glass with care to protect eyes, and don't fail to break the window on which label "Emergency exit" is stuck.

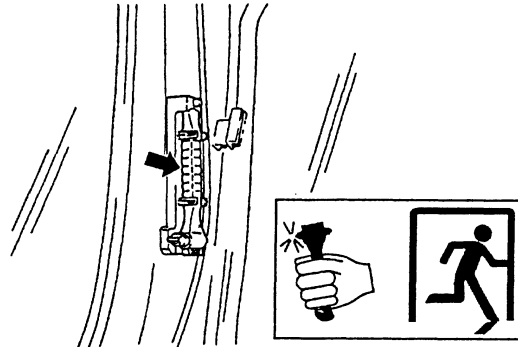

Fig. 2-1 Life hammer and "Emergency Exit" seal

2.2 WHEN IT IS IMPOSSIBLE TO GO OUT FROM THE SOFT GROUND BY ITSELF ;

- (1) Towing by other machine
There are holes to pass through shackle on the front and rear sides of track frame as in the right figure. Tow it with shackle and wire rope passing through those holes.

Wire dia ; $\varnothing 20(0.787") \times 3m(9'10")$ or more

⚠ Before starting towing, keep away from the wire rope between two machines, and move it slowly at low speed.

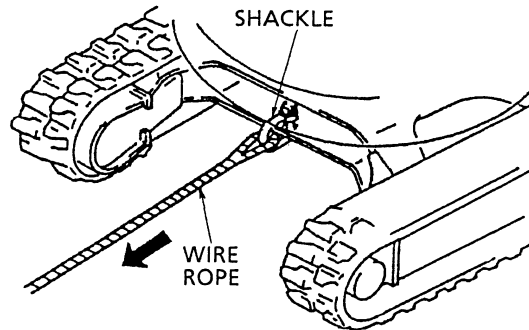



Fig. 2-2 Towing by track frame

2.3 WHEN SWING OPERATION IS UNAVAILABLE ;

- (1) Releasing swing parking brake
When swing parking solenoid and mechatro controller release command are not executed, switch swing parking brake release switch placed in the panel on the rear side of seat to "Release lock" side.
The sign "  " is displayed on monitor panel, and the swing parking brake is released, allowing swing operation. However, move the machine to the safety place and repair it as soon as possible. And when operating in regular condition, the toggle switch should be set to the "Normal" position.

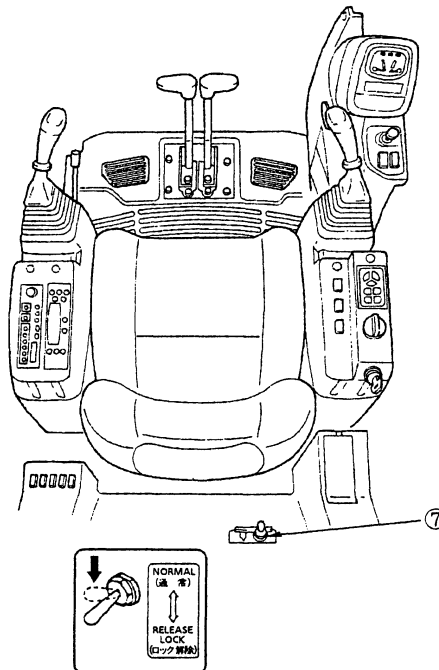

Fig. 2-3 Swing parking brake release switch ⑦

3. INTERNATIONAL UNIT CONVERSION SYSTEM

Introduction

Although this manual uses the JIS unit system. If you need SI unit, refer to following international system of units. Given hereinunder are an excerpt of the units that are related to this manual :

1. Etymology of SI Units

French : Le Système International d' Unités
English : International System of Units

2. Construction of SI Unit System

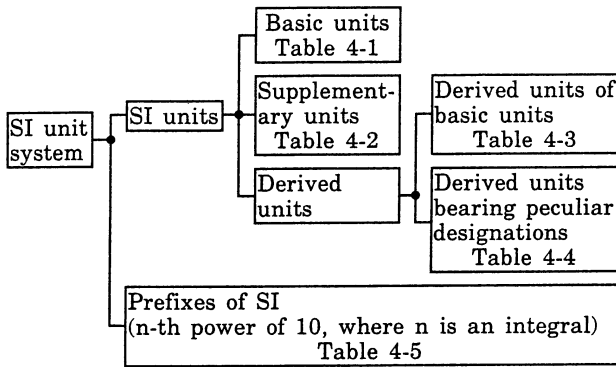

(4) Derived Units bearing Peculiar Designations

Table 4-4

QANTITIES	DESIGNATION	SIGN	DERIVED UNIT
Frequency	Hertz	Hz	1Hz = 1s ⁻¹
Force	Newton	N	1N = 1kgf·m/s ²
Pressure, Stress	Pascal	Pa	1Pa = 1N/m ²
Energy Work, Quantity of heat	Joule	J	1J = 1N·m
Power Motive power, Electric power	Watt	W	1W = 1J/s
Charge, Quantity of electricity	Coulomb	C	1C = 1A·s
Potential Voltage, Electromotive force	Volt	V	1V = 1J/C (1W/A)
Quantity of static electricity Capacitance	Farad	F	1F = 1C/V
Electric resistance	Ohm	Ω	1Ω = 1V/A
Celcius temperature	Celcius degree or degree	°C	
Illuminance	lux	ℓX	1.ℓX = 1ℓm/m ²

(1) Basic Units

Table 4-1

QANTITIES	DESIGNATION	SIGN
Length	Meter	m
Mass	Kilogram	kg
Time	Second	s
Current	Ampere	A
Thermodynamic temperature	Kelvin	K
Gram molecule	Mol	mol
Luminous intensity	Candela	cd

(2) Supplementary Units

Table 4-2

QANTITIES	DESIGNATION	SIGN
Plane angle	Radian	rad
Solid angle	Steradian	sr

(3) Derived Units of Basic Units

Table 4-3

QANTITIES	DESIGNATION	SIGN
Area	Square meter	m ²
Volume	Cubic meter	m ³
Velocity	Meter per second	m/s
Acceleration	Meter per second / second	m/s ²
Density	Kilogram per cubic meter	kg/m ³

(5) Prefixes of SI

Table 4-5

PREFIX	POWER	
	DESIGNATION	SIGN
Giga-	G	10 ⁹
Mega-	M	10 ⁶
Kilo-	k	10 ³
Hecto-	h	10 ²
Deca-	da	10
Deci-	d	10 ⁻¹
Centi-	c	10 ⁻²
Milli-	m	10 ⁻³
Micro-	μ	10 ⁻⁶
Nano-	n	10 ⁻⁹
Pico-	p	10 ⁻¹²

(6) Unit Conversion Table

Table 4-6

QUANTITIES	JIS	SI	REMARKS
Mass	kg	kg	
Force	kgf	10N	9.807N
Torque	kgf·m	10N·m	9.807N·m
Pressure	kgf/cm ²	0.1MPa	0.098MPa
Motive power	PS	0.7355kW	
Revolution	rpm	min ⁻¹	r/min ※1

※1 Units that are allowed to use

(7) Unit conversion logarithmic chart

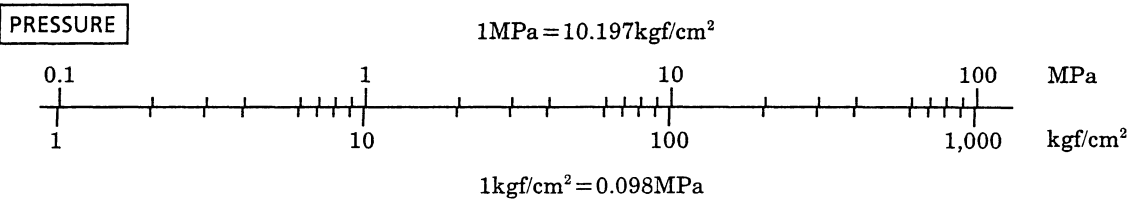
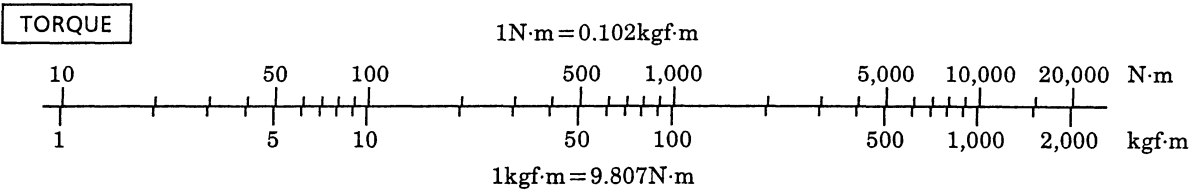
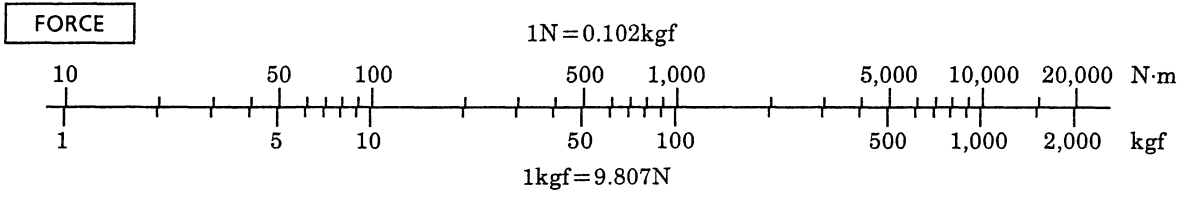

KOBELCO

Book code No. S5 YT02_{01E}

SHOP MANUAL SK70SR **YT02**

SPECIFICATION

TABLE OF CONTENTS

1. NAME OF COMPONENTS	1
2. GENERAL DIMENSION	2
3. WEIGHT OF COMPONENTS	3
4. TRANSPORTATION DIMENSION AND WEIGHT	4
5. MACHINE LIFTING PROCEDURE	7
6. WORKING RANGE	9
7. LIFTING DIAGRAM	11
8. SPECIFICATIONS AND PERFORMANCE	20
9. TYPE OF CRAWLER	21
10. TYPE OF BUCKET	22
11. COMBINATIONS OF ATTACHMENT	23
12. ENGINE SPECIFICATION	24

Applicable Machines
YT00101~

Revision	Date of Issue	Remarks
First edition	July, 1998	S5YT0201E K

1. NAME OF COMPONENTS

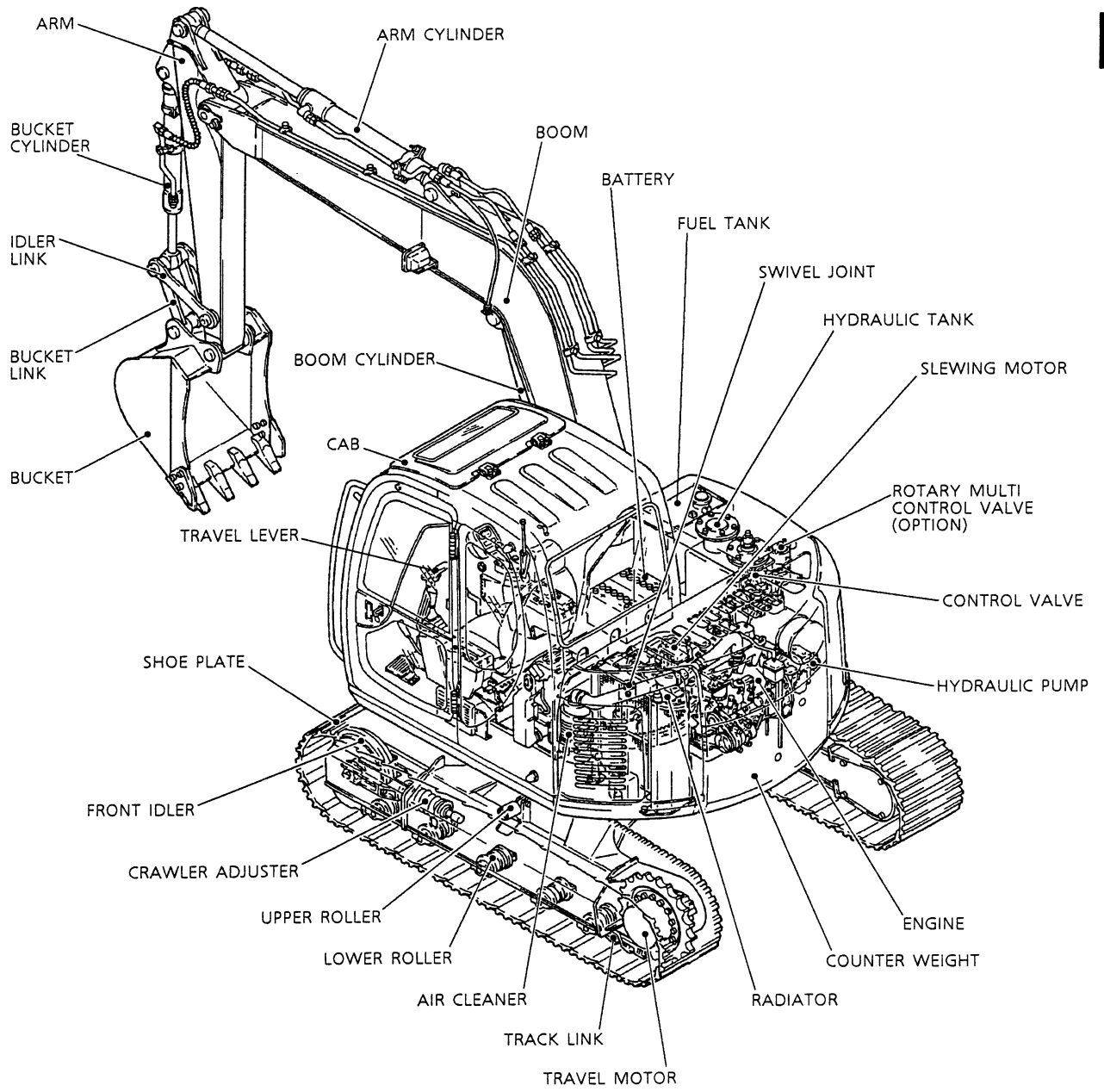

2. GENERAL DIMENSION

Unit : mm (ft-in)

2.1 2.07M (6ft-9in) ARM

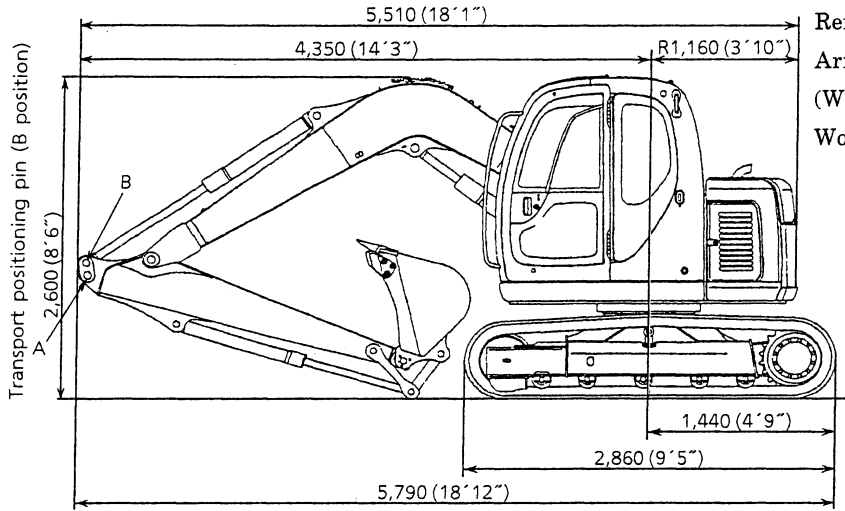

Reference :

Arm cylinder pin A position

(Working position)

Working height ; 2920mm (9ft-7in)

2.2 1.65M (5ft-5in) ARM

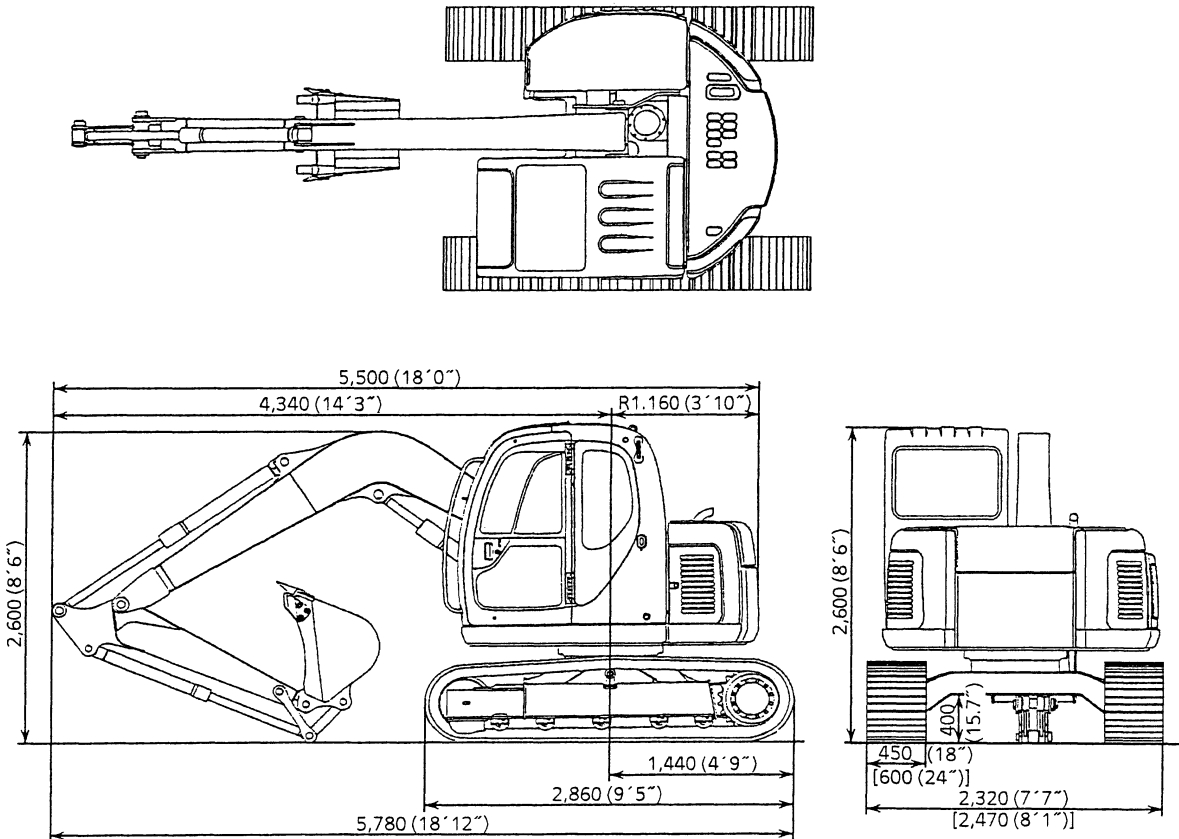

3. WEIGHT OF COMPONENTS

		Unit : kg (lbs)	
Item	Model	2.07M (6ft-9in) Arm + 600mm (24in) shoe	1.65M (5ft-5in) Arm + 450mm (18in) shoe
Machine complete		6,960 (15,300)	6,700 (14,800)
1. Upper frame assy (including the following :)		3,250 (7,170)	←
1.1 Counterweight		820 (1,810)	←
Counterweight (Add-on)		400 (882)	←
1.2 Cab		210 (463)	←
1.3 Engine		※ 240 (529)	←
1.4 Hydraulic oil tank		※ 64 (141)	←
1.5 Fuel tank		※ 46 (101)	←
1.6 Slewing motor (including reduction unit)		67 (148)	←
1.7 Control valve		62 (137)	←
1.8 Boom cylinder		※ 92 (203)	←
1.9 Pin (2pcs. for mounting boom)		14 (31)	←
1.10 Pump		48 (106)	←
1.11 Radiator		44 (97)	←
		Including 125kg(276 lbs) of grease, water, etc.	
2. Lower frame assy (including the following :)		2,590 (5,710)	2,370 (5,230)
2.1 Slewing bearing		115 (254)	←
2.2 Travel motor (including reduction unit)		90 (198)×2	←
2.3 Upper roller		4 (9)×2	←
2.4 Lower roller		15 (33)×2	←
2.5 Front idler		44 (97)×2	←
2.6 Track tension adjuster		28 (62)×2	←
2.7 Sprocket		27 (60)×2	←
2.8 Swivel joint		21 (46)	←
2.9 Track link with 450mm (18in) shoes assy		420 (926)×2	←
Track link with 600mm (24in) shoes assy		530 (1,170)×2	←
Track link with 600mm (24in) triangle shoes assy		440 (970)×2	←
2.9.1 Track link assy		160 (353)×2	←
3. Attachment			
(3.72m (12ft-2in) Boom+2.07m (6ft-9in) Arm+0.22m ³ (0.28cu-yd) Bucket)		1,120 (2,470)	—
(3.72m (12ft-2in) Boom+1.65m (5ft-5in) Arm+0.28m ³ (0.37cu-yd) Bucket)		—	1,080 (2,380)
3.1 Bucket assy		190 (419)	200 (441)
3.2 Arm assy (including the following :)		300 (660)	250 (551)
3.2.1 Arm		180 (297)	130 (287)
3.2.2 Bucket cylinder		※ 44 (97)	←
3.2.3 Idler link		6 (13)×2	←
3.2.4 Bucket link		8 (18)×2	←
3.2.5 Pin (2pcs. for mounting bucket cylinder / 2pcs. for mounting bucket)		17 (37)	←
3.3 Boom assy (Including the following :)		630 (1,390)	←
3.3.1 Boom		390 (860)	←
3.3.2 Arm cylinder		※ 72 (159)	←
3.3.3 Pin (Mounting arm · Mounting arm cylinder)		16 (35)	←
4. Lubricant and water (including the following :)		125 (276)	←
4.1 Hydraulic oil		47 (104)	←
4.2 Engine oil		3 (7)	←
4.3 Fuel		70 (154)	←
4.4 Water		5 (11)	←

NOTE : Numerical values marked ※ indicate the dry weight.

4. TRANSPORTATION DIMENSION AND WEIGHT

■ OVERALL DIMENSIONS OF MACHINE ON A TRAILER

● OVERALL DIMENSIONS OF A COMPLETE MACHINE ON A TRAILER

Item	Type	2.07M (6ft-9in) Arm + 600mm (24in) shoes	1.65M (5ft-5in) Arm + 450mm (18in) shoes
Width	mm(ft-in)	2,470 (8'1")	2,320 (7'7")
Weight	kg(lbs)	6,960 (15,300)	6,700 (14,800)

Specification :

- The parenthesis shows 2.07m arm model.
- Regarding 2.07m arm machine, put the arm cylinder rod in a transport position (B) by referring to the outside dimensions on page 2.

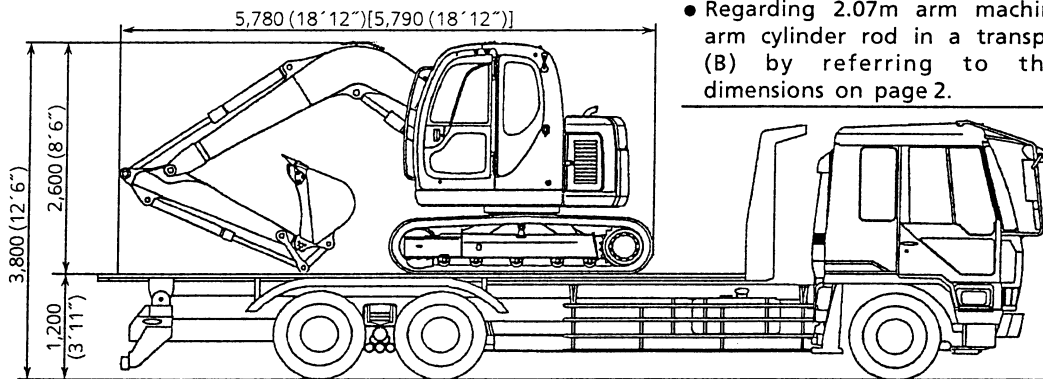

● OVERALL DIMENSIONS OF WITHOUT ARM AND BUCKET

Combination	Type	A : Shoe width mm (ft-in)	L : Length mm (ft-in)	H : Height mm (ft-in)	W : Width mm (ft-in)	Weight kg (lbs)
Without arm and bucket		600 (24")	5,670 (18'7")	2,600 (8'6")	2,470 (8'1")	6,590 (14,500)
		450 (18")	5,670 (18'7")	2,600 (8'6")	2,320 (7'7")	6,370 (14,000)

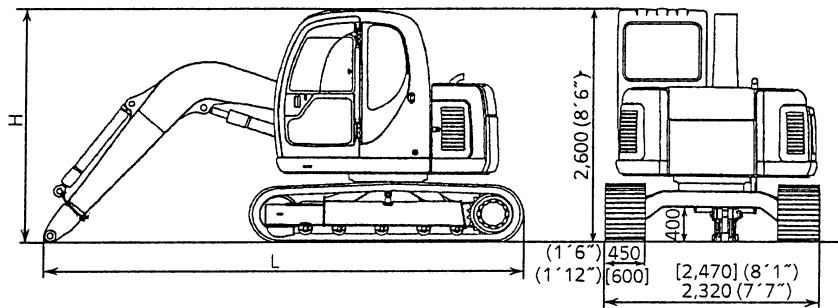

● OVERALL DIMENSIONS OF WITHOUT BOOM, ARM AND BUCKET

Combination	Type	A : Shoe width mm (ft-in)	L : Length mm (ft-in)	H : Height mm (ft-in)	W : Width mm (ft-in)	Weight kg (lbs)
Without boom, arm and bucket		600 (24")	2,860 (9'5")	2,600 (8'6")	2,470 (8'1")	5,900 (13,000)
		450 (18")	2,860 (9'5")	2,600 (8'6")	2,320 (7'7")	5,650 (12,500)

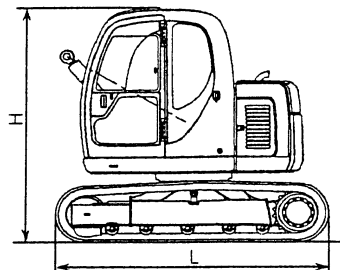

● OVERALL DIMENSIONS OF BOOM

Item	Type	3.72m (12ft-2in) Boom
Length×Height×Width L×H×W	m(ft-in)	4.09×1.57×0.56 (13'5"×5'2"×1'10")
Weight	kg (lbs)	500 (1,100)

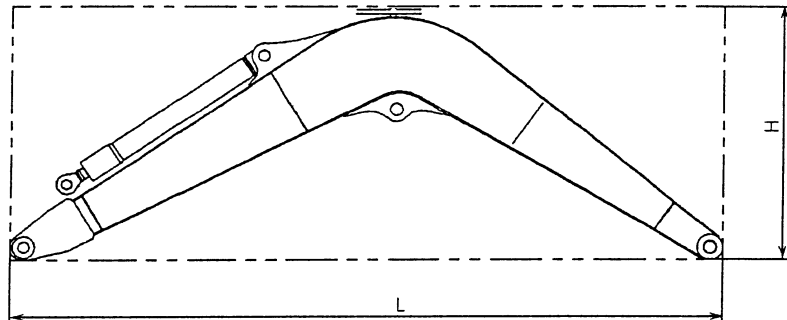

● OVERALL DIMENSIONS OF ARM+BUCKET

Item	Type	2.07m (6ft-9in) Arm + 0.22m ³ (0.29cu-yd) Bucket	1.65m (5ft-5in) Arm + 0.28m ³ (0.37cu-yd) Bucket
Length×Height×Width L×H×W	m(ft-in)	3.61×0.70×0.65 (11'10"×2'4"×2'2")	3.14×0.70×0.75 (10'4"×2'4"×2'6")
Weight	kg (lbs)	480 (1,100)	450 (990)

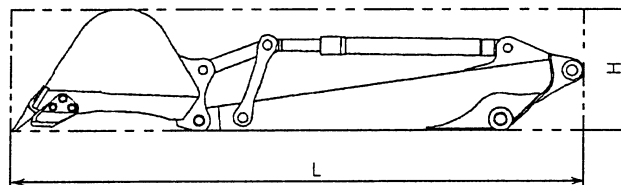

● OVERALL DIMENSIONS OF ARM

Item	Type	2.07 (6ft-9in) Arm	1.65m (5ft-5in) Arm
Length×Height×Width L×H×W	m(ft-in)	2.64×0.53×0.36 (8'8"×1'9"×1'2")	2.17×0.53×0.36 (7'1"×1'9"×1'2")
Weight	kg (lbs)	290 (640)	250 (550)

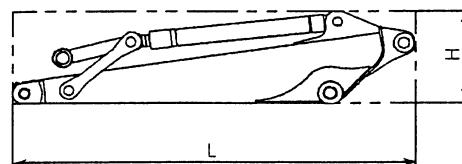



Suggest:

For more complete manuals. Please go to the home page.

<https://www.ebooklibonline.com>

If the above button click is invalid. Please download this document first, and then click the above link to download the complete manual.

Thank you so much for reading

● OVERALL DIMENSIONS OF BUCKET

Type	Hoe bucket			
Length×Height×Width L×H×W m (ft-in)	1.10×0.60×0.40 (3'7"×1'12"×1'4")	0.98×0.89×0.48 (3'3"×2'11"×1'7")	0.98×0.89×0.55 (3'3"×2'11"×1'10")	0.98×0.89×0.65 (3'3"×2'11"×2'2")
Weight kg (lbs)	150 (330)	150 (330)	170 (380)	190 (420)
Bucket capacity m ³ (cu-yd)	0.11 (0.14)	0.14 (0.18)	0.18 (0.23)	0.22 (0.28)

Type	Hoe bucket		V-bucket	Slope finishing bucket
Length×Height×Width L×H×W m (ft-in)	0.98×0.89×0.75 (3'3"×2'11"×2'6")	0.98×0.89×0.85 (3'3"×2'11"×2'9")	1.08×0.47×1.41 (3'6"×1'6"×4'7")	0.79×0.62×1.50 (2'7"×2'0"×4'11")
Weight kg (lbs)	200 (440)	220 (490)	180 (340)	300 (660)
Bucket capacity m ³ (cu-yd)	0.28 (0.37) STD	0.35 (0.45)	0.24 (0.31)	0.26 (0.34)

● Hoe bucket

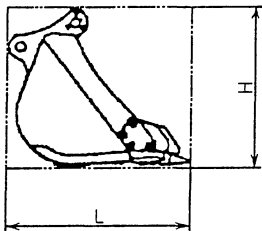

● V-bucket

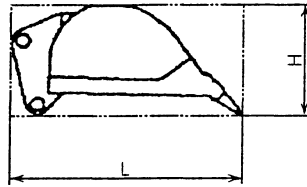

● Slope finishing bucket

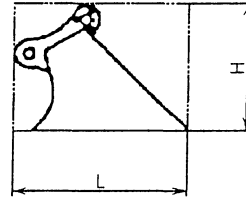

5. MACHINE LIFTING PROCEDURE

■ LIFTING PROCEDURES FOR MACHINE COMPLETE

Those who operate a crane for lifting and slinging operations must have the following qualifications:

- License for moving crane operator
- Certificate showing the receiving a wire rope slinging training course

⚠ WARNING

- The wire ropes to be used for lifting the machine should have sufficient strength against the machine weight.
- Improper lifting method and / or roping manner might cause for a movement or slip of the machine while it is lifted up, resulting serious injury or damages on the machine.
- Do not impose a load quickly on the wire ropes and slings.
- When the lifting work is carried out in cooperation with plural persons, make sure to confirm every situations with exchanging signals with each other.
- During the lifting work, keep any persons away from around the lifting machine especially under the machine.

Lift the machine on a flat place

- 1] Operate the control levers so each attachment take the positions in the figure.
- 2] After the engine stops, confirm that there is no obstacle around the operator's seat, turn the safety lock lever to "LOCKED POSITION" and get off the machine.
- 3] Sling a wire rope in the position in the figure on the right, using a lifting tool.
- 4] Operate the crane as below :
 1. Take off.
 2. Confirm safety.
 3. Wind up.

Land the machine on the ground gently.

Tools name	Remarks
Wire rope ①	∅20×13.4m (0.8in×44ft) 1pc.
Wire rope ②	∅20×13.3m (0.8in×44ft) 1pc.
Spreader bars ③	3.6m (12ft) 2pcs.

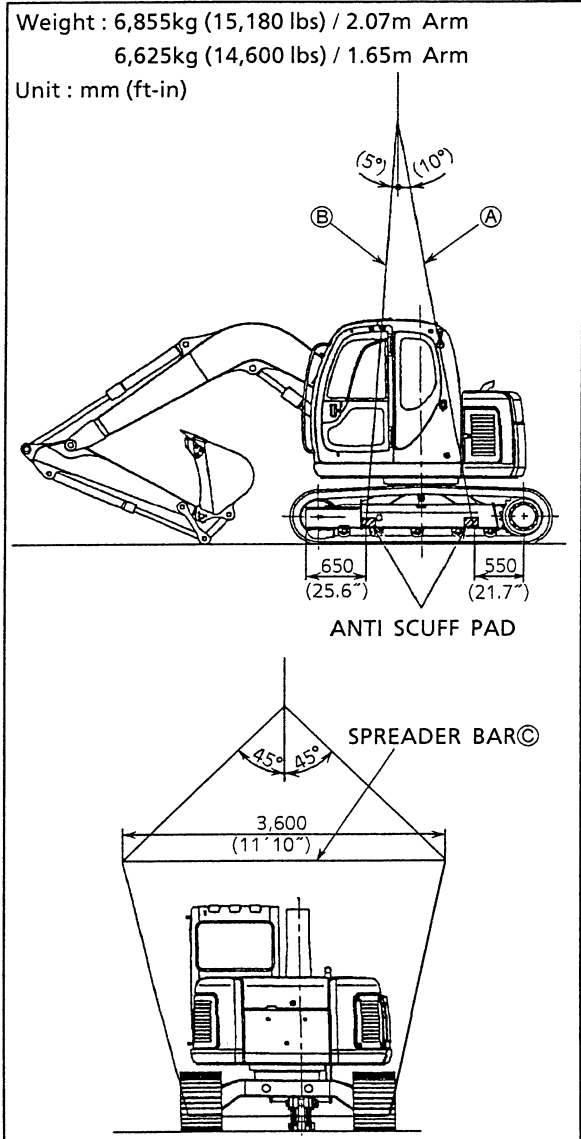

<https://www.ebooklibonline.com>

Hello dear friend!

Thank you very much for reading.

Enter the link into your browser.

The full manual is available for immediate download.

<https://www.ebooklibonline.com>