

KOBELCO

SERVICE MANUAL

Compact Hydraulic Excavator

SK27SR-5 Acera

S5PV0021E02

Issued August 2010

APPLICABLE:

SK27SR-5 PV13 - and higher

COMPACT HYDRAULIC EXCAVATOR

SHOP

MANUAL

model

SK27SR-5

ACERA

INDEX

1	SPECIFICATIONS SECTION
2	MAINTENANCE SECTION
3	SYSTEM SECTION
4	DISASSEMBLY SECTION
5	TROUBLESHOOTING
6	ENGINE SECTION
7	PROCEDURE OF INSTALLING OPTIONS SECTION

MAINTENANCE SPECIFICATIONS

SYSTEM

DISASSEMBLING

TROUBLESHOOTING

E/G

OPT.

KOBELCO

Book Code No. **S5PV0021E02**

INDEX

NA

SK27SR-5

Book Code No. Distribution Year–Month			Title	Index No.
S5PA0105E01 2010-05		SPECIFICATIONS	OUTLINE	1
S5PV0221E02 2010-06			SPECIFICATIONS	2
S5PV0321E02 2010-06			ATTACHMENT DIMENSIONS	3
S5PV1121E02 2010-06		MAINTENANCE	TOOLS	11
S5PV1221E02 2010-06			STANDARD MAINTENANCE TIME SCHEDULE	12
S5PV1321E02 2010-06			MAINTENANCE STANDARD AND TEST PROCEDURE	13
—		SYSTEM		
S5PV2221E02 2010-06			HYDRAULIC SYSTEM	22
S5PV2321E02 2010-06			ELECTRIC SYSTEM	23
S5PV2421E02 2010-06			COMPONENTS SYSTEM	24
—				
S5PA3105E01 2010-05		DISASSEMBLING	GENERAL DISASSEMBLY & ASSEMBLY	31
S5PV3221E02 2010-06			ATTACHMENT	32
S5PV3321E02 2010-06			UPPER SLEWING STRUCTURE	33
S5PV3421E02 2010-06			TRAVEL SYSTEM	34
—		TROUBLESHOOTING		
S5PW4231E02 2010-06			HYDRAULIC SYSTEM	42
S5PW4331E02 2010-06			ELECTRICAL SYSTEM	43
S5PW4431E02 2010-06			ENGINE	44
S5PV5121E02 2010-06		E/G	ENGINE	51
—				
—				
—				
PV13~			APPLICABLE MACHINES	

33 1

42 34 2

51 43 11 3

44 12

13

22

31 23

32 24

<https://www.ebooklibonline.com>

Hello dear friend!

Thank you very much for reading.

Enter the link into your browser.

The full manual is available for immediate download.

<https://www.ebooklibonline.com>

NOTE:

This Manual is prepared as technical material containing the information necessary for the maintenance and repairing services of hydraulic excavators. The material is categorized into 7 Chapters, Specification, Maintenance, System, Disassembly, Troubleshooting, Engine, and Installation Procedures for Optional Attachment.

- The Chapter "Specification" describes the specifications for entire machine and material. It contains information for attachment replacement and repair.
 - The Chapter "Maintenance" describes the material, which is helpful for maintenance service and adjustments for entire machine.
- The Chapter "System" describes the operating systems. It contains information for the hydraulic system, electric system, components, etc.
- The Chapter "Disassembly" describes the removal and installing of assembly mounted on the upper structure and undercarriage, and the assembling and disassembling of the associated hydraulic equipment.
- The Chapter "Troubleshooting" describes common faults and repair guidelines.
- The Chapter "Engine" describes the engine and the usage of the "Maintenance Manual" provided by the engine manufacturer.
- The Chapter "Installation Procedures for Optional Attachment" describes the equipment added by customer request.

Any modification or adaptation which is not approved by the manufacturer may invalidate the machine's initial conformity with safety requirements and warranty.

The information in this manual is provided on the basis of information that was available at the time the manual was written. Settings, procedures, part numbers, software and other items can change. These changes can affect the service that is given to the machine. Ensure that you have complete and current information before you start any machine operation

ATTENTION: *The engine and fuel system on your machine is designed and built to government emissions standards. Tampering by dealer, customers, operators and users is strictly prohibited by law. Failure to comply could result in government fines, rework charges, invalid warranty, legal action, and possible confiscation of the machine until rework to original condition is completed. Engine service and/or repairs must be done by a certified technician only.*

1. OUTLINE

TABLE OF CONTENTS

1.1	GENERAL PRECAUTIONS FOR REPAIRS	1-3
1.1.1	PREPARATION BEFORE DISASSEMBLING	1-3
1.1.2	SAFETY IN DISASSEMBLING AND ASSEMBLING	1-3
1.1.3	DISASSEMBLING AND ASSEMBLING HYDRAULIC EQUIPMENT	1-5
1.1.4	ELECTRICAL EQUIPMENT	1-7
1.1.5	HYDRAULIC PARTS	1-8
1.1.6	WELDING REPAIR	1-8
1.1.7	ENVIRONMENTAL MEASURES	1-8
1.2	INTERNATIONAL UNIT CONVERSION SYSTEM (Based on MARKS' STANDARD HANDBOOK FOR MECHANICAL ENGINEERS)	1-9

1. OUTLINE

Issue	Date of Issue	Applicable Machines	Remarks
First Edition	June, 2009	E10SR : PA03-05001~	S5PA0105E01 (NHK-EUR)
↑	February, 2010	CX50B : PJ06-08001~	↑ (CASE-AUS)
↑	↑	E50B : PJ06-08001~	↑ (NH-AUS)
↑	↑	SK20SR-5 : PM10-10001~ SK27SR-5 : PV13-33001~	↑ (KCM S.E.ASIA&OCE)
↑	March, 2010	SK30SR-5 : PW14-46519~ SK35SR-5 : PX15-21105~	↑ (KCM North America)
↑	↑	CX31B : PW14-46519~ CX36B : PX15-21105~	↑ (CASE-NA)
↑	↑	E30B : PW14-46519~ E35B : PX15-21105~	↑ (NH-NA)
↑	↑	CX27B : PV13-33292~	↑ (CASE-NA)
↑	↑	E27B : PV13-33292~	↑ (NH-NA)
↑	April, 2010	SK50SR-5 : PJ06-09807~	↑ (KCM North America)
↑	↑	CX50B : PJ06-09807~	↑ (CASE-NA)
↑	↑	E50B : PJ06-09807~	↑ (NH-NA)
↑	↑	SK30SR-5 : PW14-46519~ SK35SR-5 : PX15-21105~	↑ (KCM S.E.ASIA&OCE)
↑	↑	CX31B : PW14-46519~ CX36B : PX15-21105~	↑ (CASE-AUS)
↑	↑	E30B : PW14-46519~ E35B : PX15-21105~	↑ (NH-AUS)
↑	↑	CX27B : PV13-33001~	↑ (CASE-Australia)
↑	↑	E27B : PV13-33001~	↑ (NH-AUS)
↑	May, 2010	SK40SR-5 : PH07-06609~ SK50SR-5 : PJ06-09807~	↑ (KCM S.E.ASIA&OCE)
↑	↑	E50B : PJ06-09807~	↑ (NH-AUS)
↑	↑	CX50B : PJ06-09807~	↑ (CASE-AUS)
↑	↑	SK27SR-5 : PV13-33453~	↑ (NA)
↑	↑	CX27B : PV13-33453~	↑ (CASE-NA)
↑	↑	E27B : PV13-33453~	↑ (NH-NA)

1.1 GENERAL REPAIR SAFETY

1.1.1 PREPARATION BEFORE DISASSEMBLING



(1) UNDERSTAND THE OPERATING PROCEDURE

Read the OPERATOR'S MANUAL carefully to understand the operating procedure.

(2) CLEAN THE MACHINE

Remove soil, mud, and dust from the machine before servicing. This will allow better visibility of components and lessen contamination issues.

(3) INSPECTION

Identify the components to be serviced. Make note of surrounds (i.e. repair facility or field repair). Request all service parts prior to servicing.

(4) RECORDING

Make note and record:

1. Inspection date and place.
2. Model name, applicable machine number, and hour meter read.
3. Repair issue, place and cause.
4. Visible oil leakage, water leakage and damage.
5. Clogging of filters, oil level, oil quality, oil contamination and loosening of connections.
6. Note if problem exists based on the operation rate per month calculated from hour meter indication after the previous inspection date.

(5) WORKING CONDITIONS AND REQUIREMENTS

1. Tools required for repair work.
2. Prepare space to place the disassembled parts.
3. Prepare oil containers for draining oil etc.

1.1.2 SAFETY IN DISASSEMBLING AND ASSEMBLING



Avoid injury!

The safety alert symbol is used to alert you to potential personal injury hazards. Carefully read and observe all the precautionary advice contained in this manual. Failure to comply could result in death or serious injury.

W0044A

- (1) Be prepared for emergencies. Always have a first aid kit and a working fire extinguisher with you and know how to use each. Wear appropriate clothes with long sleeves, safety shoes, safety helmet and protective glasses.
- (2) Avoid loose fitting clothing, loose or uncovered long hair, jewelry.
- (3) Use the correct protective equipment when servicing this machine. Hard hats, protective glasses, protective shoes, gloves, reflector type vests, respirators and ear protection are examples of the type of equipment that may be required
- (4) Do not attempt maintenance work if you have not had the appropriate training or doubt your ability to perform the required service.
- (5) Read the repair procedure completely before starting any service or maintenance task.

1. OUTLINE

- (6) Before beginning any inspection or maintenance procedures, secure a "DO NOT OPERATE" tag to the operator's console to inform the operator that the machine will be inoperable for inspection and maintenance. This tag will prevent accidental starting of the machine.
- (7) Disconnect the battery before working on the electrical system. Know the consequences of disconnecting any electronic or computer devices.
- (8) Avoid lubrication or mechanical adjustments with the machine in motion or the engine operating. If the engine must be in operation to make certain adjustments, place the transmission in neutral, apply the parking brake, place the equipment in a safe position, securely block the tracks and use extreme caution.
- (9) Securely block the machine or any component that may fall before working on the machine or component. If possible, use a back up or secondary blocking device, also.
- (10) To prevent unexpected movement, securely block working elements when repairing or changing working tool parts such as cutting edges.
- (11) Never make repairs on pressurized components, fluid, gas or mechanical until the pressure has been relieved according to the manufacturer's instructions.
- (12) Use extreme caution when removing radiator caps, drain plugs, grease fittings or pressure taps. Park the machine and let it cool down before opening a pressurized tank.
- (13) Release all pressure before working on systems which have an accumulator. Use a piece of cardboard, newspaper, or wood to check for pressurized leaks to prevent fluid penetrating the skin. Pressurize accumulators with the proper gas according to manufacturer's recommendations.
- (14) When absolutely necessary to tow the machine, do not exceed the recommended towing speed. Be sure the towing machine has sufficient braking capacity to stop the towed load. If the towed machine cannot be braked, a tow bar must be used or two towing machines must be used. - one in front pulling and one in the rear to act as a brake. Avoid towing over long distances.
- (15) Observe proper maintenance procedures.
- (16) Whenever servicing or replacing hardened pins, etc., use a brass drift or other suitable material between the hammer and pin. Alternate: Use a brass hammer, drift or suitable material on the pin, etc.
- (17) Keep the brakes and steering systems in good operating condition.
- (18) Replace all missing, illegible or damaged safety signs. Keep all safety signs clean.
- (19) Use proper tools, and replace or repair defective tools.
- (20) Support the machine and attachment with supports or blocks if the work must be performed in a lift condition.

1.1.3 DISASSEMBLING AND ASSEMBLING HYDRAULIC EQUIPMENT



(1) REMOVING HYDRAULIC EQUIPMENT

1. Before disconnecting any hydraulic line, fitting, disconnect, release the hydraulic pressure in the system.
2. Clean the exterior surface of the equipment before disassembling.
3. Carefully drain oil from the hydraulic lines into clean, uncontaminated containers.
4. Apply plugs or caps on the line ends to avoid oil spillage and contamination.

(2) DISASSEMBLING HYDRAULIC EQUIPMENT

1. Do not disassemble, reassemble or modify the hydraulic equipment without the permission of the manufacturer. The manufacturer will not be responsible for the performance and function of the product after unauthorized modification. Such modifications may void the equipment warranty.
2. Use matching marks to facilitate reassembling work.
3. Before starting the work, read the disassembly procedure, and determine if work can be completed correctly by service personnel.
4. Use the special jig and tools when specified.
5. Place the removed parts in order and attach tags to facilitate reassembly.
6. Note the location and quantity of parts commonly applied to multiple locations.

(3) INSPECTING PARTS

1. Ensure that the disassembled parts are free from seizure, interference and uneven contact.
2. Measure and record wear condition of parts and clearance.
3. If the problem is found in a part, repair or replace it with a new one.

(4) REASSEMBLING HYDRAULIC EQUIPMENT

1. When cleaning parts, make certain ventilation is adequate. Wear a breathing mask if necessary.
2. Perform rough and finish cleaning before assembling.
3. Remove washing oil with air and apply clean hydraulic or gear oil for assembling.
4. Always replace the removed O-rings, backup rings and oil seals with new ones.
5. Remove dirt and moisture and degrease the surface where liquid gasket to be applied.
6. Remove rust preventive agent from the new parts before use.
7. Fit bearings, bushings and oil seals using special jigs.
8. Assemble the parts utilizing matching marks.
9. Ensure all the parts are completely assembled.

1. OUTLINE

(5) INSTALLING hydraulic equipment

1. Ensure hydraulic oil and lubricant are properly supplied.
2. Perform air bleeding when :
 - a. Hydraulic oil changed
 - b. Parts of suction side piping replaced
 - c. Hydraulic pump installed
 - d. Swing motor installed
 - e. Travel motor installed
 - f. Hydraulic cylinder installed
3. Perform air bleeding of the hydraulic pump and swing motor after loosening the upper drain plug, starting the engine. Keep the engine at low idle.
Complete the air bleeding when seeping of hydraulic oil is apparent, and tightly plug.
4. Perform air bleed of the travel motor and the hydraulic cylinders by running the engine for more than 5 minutes at low speed without load.
5. Perform air bleeding of pilot line by performing a series of digging, slewing and travel.
6. Check hydraulic oil level after placing the attachment in the oil check position, and replenish oil if necessary.

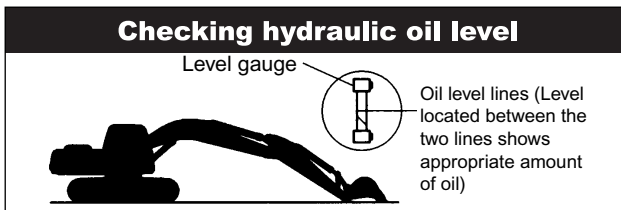

NOTICE: Always make certain the machine has the correct hydraulic oil and always bleed air from the hydraulic system. Operating the equipment without oil or with air in the lines can result in damage to the machine.

NOTICE: Do not allow the hydraulic cylinder to bottom on the stroke end immediately after maintenance.

1.1.4 ELECTRICAL EQUIPMENT

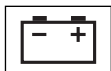

⚠ WARNING ⚠

BATTERY ACID CAUSES SEVERE BURNS. Batteries contain sulfuric acid. Avoid contact with skin, eyes or clothing.

Antidote: EXTERNAL - Flush with water.

Antidote: INTERNAL - Drink large quantities of water or milk.

DO NOT induce vomiting. Seek medical attention immediately.

EYES - Flush with water for 15 minutes and seek medical attention immediately.

M111A

⚠ WARNING ⚠

Explosive gas!

Batteries emit explosive hydrogen gas and other fumes while charging. Ventilate the charging area. Keep the battery away from sparks, open flames, and other ignition sources. Never charge a frozen battery.

Failure to comply could result in death or serious injury.

W005A

- (1) Disconnect battery before performing any electrical repairs.
- (2) Handle batteries carefully.
- (3) Turn the key OFF prior to connecting and disconnecting battery.
- (4) Disconnect electrical connectors by holding and pressing the lock. Do not pull the wire to apply force.
- (5) Connect the connector and ensure it is completely locked.
- (6) Turn the key OFF prior to touching the terminal of starter or generator.
- (7) Remove the ground (earth) terminal of battery when handling tools around the battery or its relay.
- (8) Do not splash water on the electrical equipment and connectors when cleaning the machine or components.
- (9) Check for moisture adhesion inside waterproof connector after removal. If moisture adhesion is found, dry it completely with low pressure air before the connection.

1. OUTLINE

1.1.5 HYDRAULIC PARTS

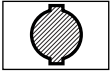

(1) O-RING

- Ensure O-rings have elasticity and are not damaged.
- Use the appropriate O-rings. O-rings are made of various kinds of materials and have a variety of compositions in order to adhere to a variety of parts. Always use O-rings designed specifically for component being repaired.
- Fit the O-rings without distortion and/or wrinkles or folds.
- Always replace floating seals as a pair.

(2) Flexible hose (F hose)

- Use the appropriate parts. Different parts are used depending on the working pressure even if the size of fitting and the total length of the hose is same.
- Tighten the fitting to the specified torque.
Make certain there is no kink, tension, interference nor oil leakage from hose.

1.1.6 WELDING REPAIR

- (1) Refer repair welding to qualified personnel according to the appropriate procedure.
- (2) Disconnect the ground (earth) cable of the battery before starting the repair.
Failure to do so will cause damage to the electrical equipment.
- (3) Do not weld near flammable materials.
- (4) Before starting the repair of the attachment, do not fail to cover the plated surface of the piston rod with a flameproof shield to prevent it from being exposed to sparks.

1.1.7 ENVIRONMENTAL MEASURES

- (1) Engine exhaust fumes can cause death or serious injury. If necessary to run the engine, make certain there is adequate ventilation.
- (2) Waste disposal
Dispose of the following parts according to the relevant regulations :
Waste oil and waste container
Battery
- (3) High pressure fluids
High pressure fluid can penetrate the skin and cause serious injury. Search for leaks with a piece of cardboard. Protect hands and body from high-pressure fluids. If an injury occurs, seek medical treatment immediately. Any fluid injected into the skin must be surgically removed or gangrene may develop.
- (4) Precautions for handling hydraulic oil
Exposure of eyes to hydraulic oil will cause inflammation. Wear protective safety glasses before handling to avoid an accident. If an eye is exposed to the oil, take the following emergency measures :
-When an eye exposed :
Immediately flood with water.
-When swallowed :
Do not induce vomiting, seek medical treatment immediately.
-When skin exposed:
Wash with water and soap.
- (5) Others
Use replacement parts and lubricants authorized as the manufacturer's genuine parts.

1.2 INTERNATIONAL UNIT CONVERSION SYSTEM (Based on MARKS' STANDARD HANDBOOK FOR MECHANICAL ENGINEERS)

This manual includes International System of Unit and Foot-Pound System of Units, if you need SI unit, refer to the following international system of units.

Units that are related to this manual:

1. Etymology of SI Unites

French: Le Systeme International d' Unites

English: International System of Units

2. Construction of SI Unit System

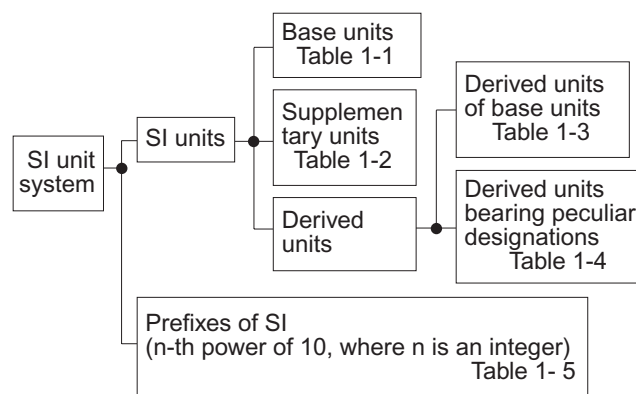

1) Base units

Table 1-1

QUANTITY	UNIT	SYMBOL
Length	meter	m
Mass	kilogram	kg
Time	second	s
Electric current	ampere	A
Thermodynamic temperature	kelvin	K
Amount of substance	mol	mol
Luminous intensity	candela	cd

2) Supplementary units

Table 1-2

QUANTITY	UNIT	SYMBOL
Plane angle	radian	rad
Solid angle	steradian	sr

3) Derived Units

Table 1-3

QUANTITY	UNIT	SYMBOL
Area	square meter	m ²
Volume	cubic meter	m ³
Velocity	meter per second	m/s
Acceleration	meter per second squared	m/s ²
Density	kilogram per cubic meter	kg/m ³

4) Derived Units bearing Peculiar Designations

Table 1-4

QUANTITY	UNIT	SYMBOL	FORMULA
Frequency	hertz	Hz	1/s
Force	newton	N	kg • m/s ²
Pressure and Stress	pascal	Pa	N/m ²
Energy, Work and Quantity of heat	joule	J	N•m
Power	watt	W	J/s
Quantity of electricity	coulomb	C	A•s
Electric potential difference, Voltage, and Electromotive force	volt	V	W/A
Quantity of static electricity and Electric capacitance	farad	F	C/V
Electric resistance	ohm	Ω	V/A
Celcius temperature	celcius degree or degree	°C	(t+273.15)K
Illuminance	lux	lx	l m/m ²

1. OUTLINE

(5) Prefixes of SI

Table 1-5

PREFIX	SYMBOL	MULTIPLICATION FACTORS
giga	G	10^9
mega	M	10^6
kilo	k	10^3
hecto	h	10^2
deca	da	10
deci	d	10^{-1}
centi	c	10^{-2}
milli	m	10^{-3}
micro	μ	10^{-6}
nano	n	10^{-9}
pico	p	10^{-12}

(6) Unit Conversion

Table 1-6

QUANTITY	Gravitational	SI	CONVERSION FACTOR
Mass	kg	kg	
Force	kgf	N	1 kgf=9.807 N
Torque	kgf•m	N•m	kgf•m=9.807 N•m
Pressure	kgf/cm ²	MPa	1 kgf/cm ² =0.09807 MPa
Motive Power	PS	kW	1 PS=0.7355 kW
Revolution	rpm	min ⁻¹	r/min *1

*1 Units that are allowed to use.

2. SPECIFICATIONS

TABLE OF CONTENTS

- 2.1 COMPONENT LOCATION2-3
- 2.2 MACHINE DIMENSIONS2-4
- 2.3 SPECIFICATIONS AND PERFORMANCE2-5
- 2.4 MACHINE & COMPONENTS WEIGHT (DRY)2-7
- 2.5 TRANSPORTATION2-9
- 2.6 TYPE OF CRAWLER SHOES2-12
- 2.7 TYPE OF BUCKET2-13
- 2.8 ENGINE SPECIFICATIONS2-14
 - 2.8.1 SPECIFICATIONS2-14
 - 2.8.2 ENGINE PERFORMANCE CURVE2-15

2. SPECIFICATIONS

Issue	Date of Issue	Applicable Machines	Remarks
First Edition	May, 2010	SK27SR-5 : PV13-	S5PV0221E01 (NA)
Revision	June, 2010	SK27SR-5 : PV13-33453~	S5PV0221E02 (NA)

2.1 COMPONENT LOCATION

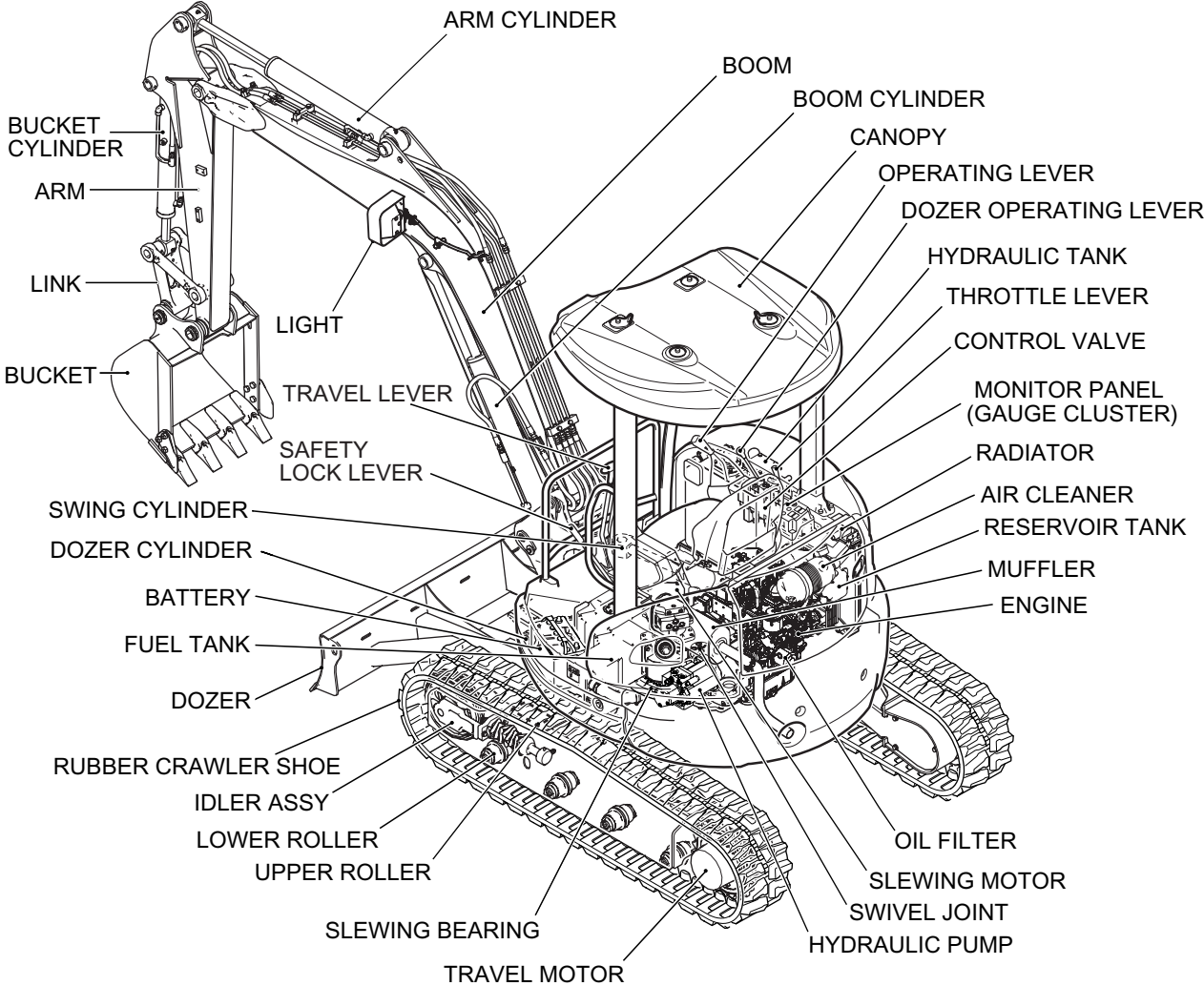

2. SPECIFICATIONS

2.2 MACHINE DIMENSIONS

(1) SK27SR-5 (CANOPY)

Unit: mm (ft-in)

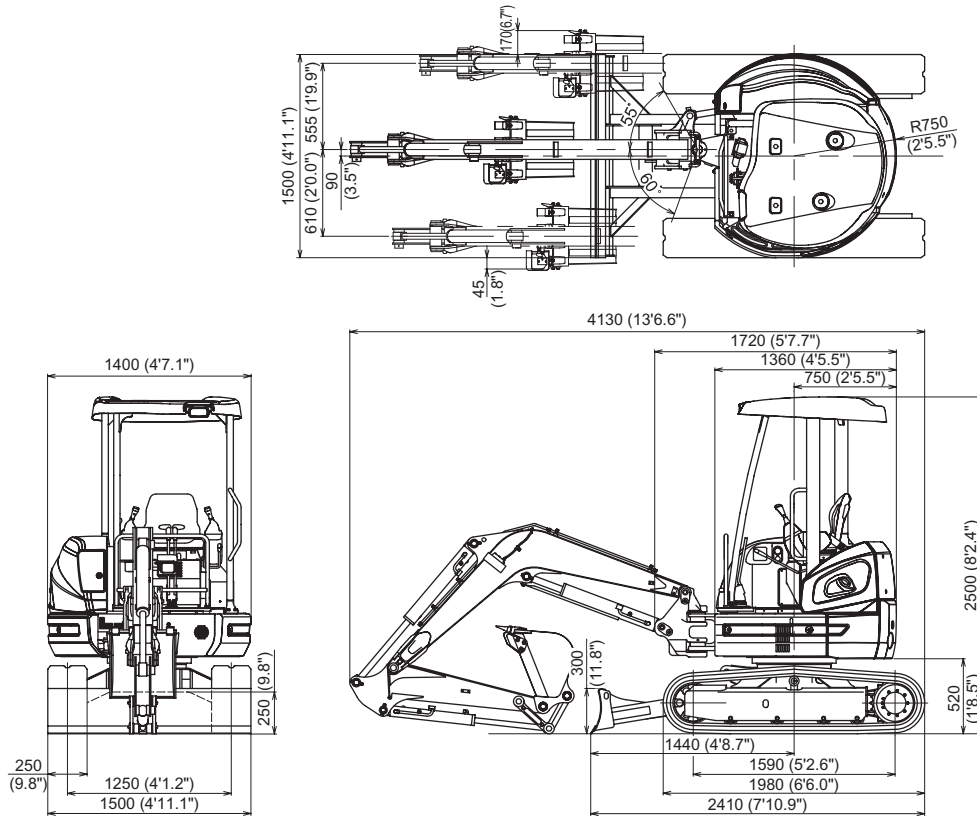

(2) SK27SR-5 (CAB)

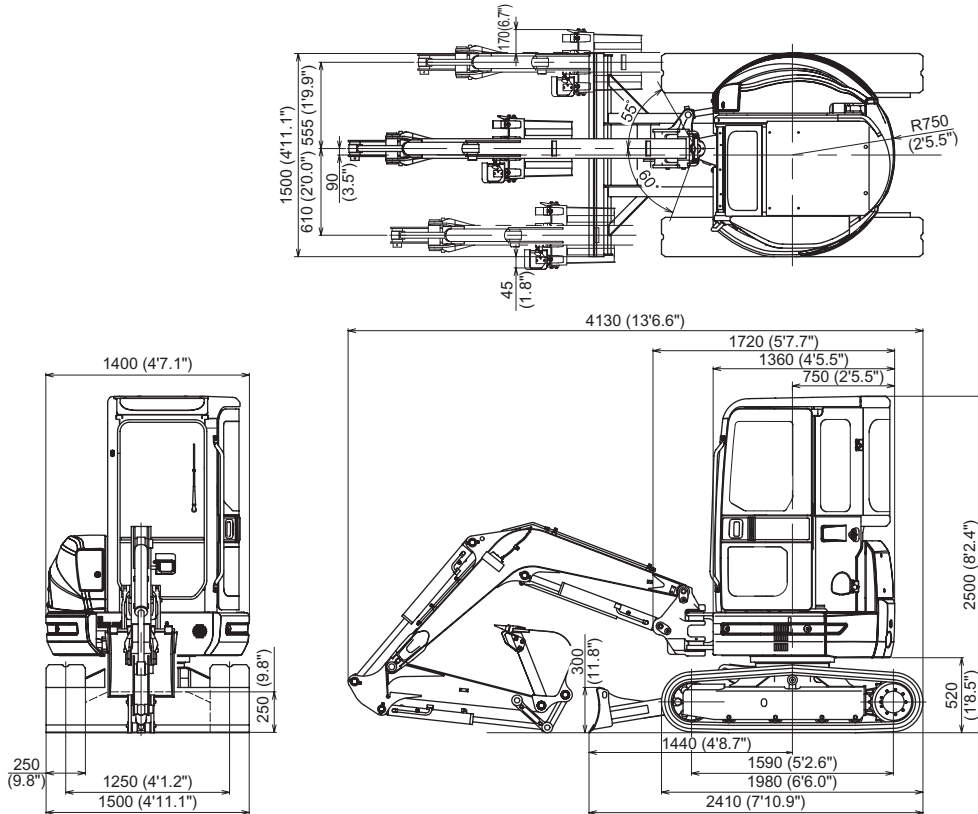



Suggest:

For more complete manuals. Please go to the home page.

<https://www.ebooklibonline.com>

If the above button click is invalid. Please download this document first, and then click the above link to download the complete manual.

Thank you so much for reading

2.3 SPECIFICATIONS AND PERFORMANCE

SPEED AND GRADEABILITY

Model	SK27SR-5				
Applicable Machines	PV13-33453~				
Shoe Type	Rubber shoe		Iron shoe (OPT)		
Slewing Speed	min ⁻¹ {rpm}	8.7 (8.7)			
Travel Speed	km/h (mph)	Low (1st)	High (2nd)	Low (1st)	High (2nd)
		2.3	4.0	2.3	4.0
Gradeability	% (degree)	58(30)			

ENGINE

Model (YANMAR)	3TNV82A-SYB			
Type	Water-cooled, 4-cycle type Swirl chamber type diesel engine			
Number of cylinders-Bore X Stroke	3 - 82 dia. mm X 84 mm (3.23 in X 3.31 in)			
Total Displacement	L	1.330 (81.2 cu-in)		
Output Rating	kW/min ⁻¹ {PS/rpm}	15.9/2,200 (21.6/2,200)		
Intermediate Torque (Net)	N-m/min ⁻¹ (lbf-ft/rpm)	79.0~86.0/1,320±100 (58.3~63.4/1,320±100)		
Starting Motor	V X kW	12 X 1.7		
Generator	V X A	12 X 40		

HYDRAULIC COMPONENTS

Hydraulic Pump	Variable displacement axial piston + gear pump			
Hydraulic Motor	Axial piston			
Hydraulic Motor w/Reducer (Travel)	2-Axial piston, 2-Speed motor			
Control Valve	10-spool multiple control valve			
Cylinder (Boom, Arm, Swing, Bucket, Dozer)	Double action cylinder			
Return Filter	Safety valve containing/Filter Type (30μ)			

SIDE DIGGING & DOZER

Type	Boom swing by hydraulic cylinder			
Boom Swing Angle	Right	55 degrees		
	Left	60 degrees		
Stroke of Dozer (above/below)	mm (in)	445 / 335 (17.5/13.2)		

2. SPECIFICATIONS

WEIGHT

Machine Weight	kg (lb)	Rubber shoe	Iron shoe
		2,490 (5490)	2,620 (5780)
Upper slewing body	kg (lb)	1,310 (2890)	<--
Travel system	kg (lb)	830 (1830)	960 (2120)
Attachment (Boom+STD Arm+STD Bucket)	kg (lb)	300 (660)	
Oil & Water	kg (lb)	50 (110)	

Note

This figure is calculated with standard bucket.

<https://www.ebooklibonline.com>

Hello dear friend!

Thank you very much for reading.

Enter the link into your browser.

The full manual is available for immediate download.

<https://www.ebooklibonline.com>