

KOBELCO

SHOP MANUAL

HYDRAULIC EXCAVATOR

**SK14
K914**

S5LR0001E-02 NA

Issued 02-1987

SK14..... L-60103~60216
K914..... LR-0117~

SHOP MANUAL model **SK14·K914**

も く じ ・ TABLE OF CONTENTS

1. 仕 様.....	SPECIFICATION	LR01
2. 運 転.....	OPERATION	LR02
3. 機器配置と重量.....	LOCATION OF COMPONENT AND WEIGHT	LR03
4. 整備基準とテスト要領.....	MAINTENANCE STANDARDS AND TEST PROCEDURES	LR04
5. トラブルシューティング.....	TROUBLE SHOOTING	LR05
6. 保 守.....	PREVENTIVE MAINTENANCE	LR06
7. 作業基準.....	WORKING STANDARDS.....	LR07

○ ショップマニュアルの各章索引法

当ショップマニュアルの全般編は上記目次に表わされています様に7項目で構成されており、その各章は右図に示される様にヘリマークで容易に索引することが出来ます。けん索を迅速に行なうためにぜひ御利用ください。

○ How to Index each Shop Manual Section

The GENERAL of this shop manual consists of 7 headings as shown above. Each section can be easily referred to by indexes appended to the margin of the page as indicated on the right. Please use the indexes for speedy reference.

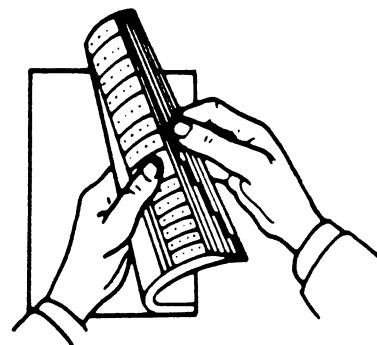

KOBELCO

**全般
GENERAL**

SK14・K914 ショップマニュアル全般編一覧
SK14・K914 LIST OF SHOP MANUAL GENERAL SECTION

名称・Title	資料 No・Book Code No.		
	配布年月・Distribution Year—Month		
仕様 SPECIFICATION	S5LR0101E① 1983-12	S5LR0101E② 1987-02	
運転 OPERATION	S5LR0201E 1983-12		
機器配置と重量 LOCATION OF COMPONENTS	S5LR0301E 1983-12	S5LR0301E① 1987-02	
整備基準とテスト要領 MAINTENANCE STANDARDS	S5LR0401E① 1983-12		
トラブルシューティング TROUBLE SHOOTING	S5LR0501E 1983-12		
保守 PREVENTIVE MAINTENANCE	S5LR0601E 1983-12		
作業基準 WORKING STANDARDS	S5L00701(E) 1983-12		
適用号機 APPLICABLE MACHINES	L-60103~60216 LR-0117~		

<https://www.ebooklibonline.com>

Hello dear friend!

Thank you very much for reading.

Enter the link into your browser.

The full manual is available for immediate download.

<https://www.ebooklibonline.com>



SHOP MANUAL **SK14·K914**

SPECIFICATION

TABLE OF CONTENTS

1. NAMES OF COMPONENTS		
1.1 Backhoe		1
1.2 Loading Shovel		2
2. MACHINE DIMENSIONS (COMPLETE MACHINE)		3
3. PERFORMANCE		5
4. TYPE OF SHOES		6
5. TYPE AND COMBINATION OF ATTACHMENTS		7
6. WORKING RANGE OF ATTACHMENTS		
6.1 Backhoe (With 3.2m Arm, 2.7m Arm)	} L-60103~60216 LR-0117~0142	9
6.2 Backhoe (With 4.8m Arm)		10
6.3 Backhoe (With 3.2m Arm, 2.7m Arm)	} LR-0143~	11
6.4 Backhoe (With 4.8m Arm)		12
6.5 Loading Shovel		13
7. LIFTING CAPACITY DIAGRAM.....		15
8. SPECIFICATIONS OF ENGINE.....		23

Applicable Machines
L-60103~60216
LR-0117~

Revision	Date of Issue	Remarks
First edition	1983. 12	120R
First revision	1987. 1	R

1. NAMES OF COMPONENTS

1.1 BACKHOE

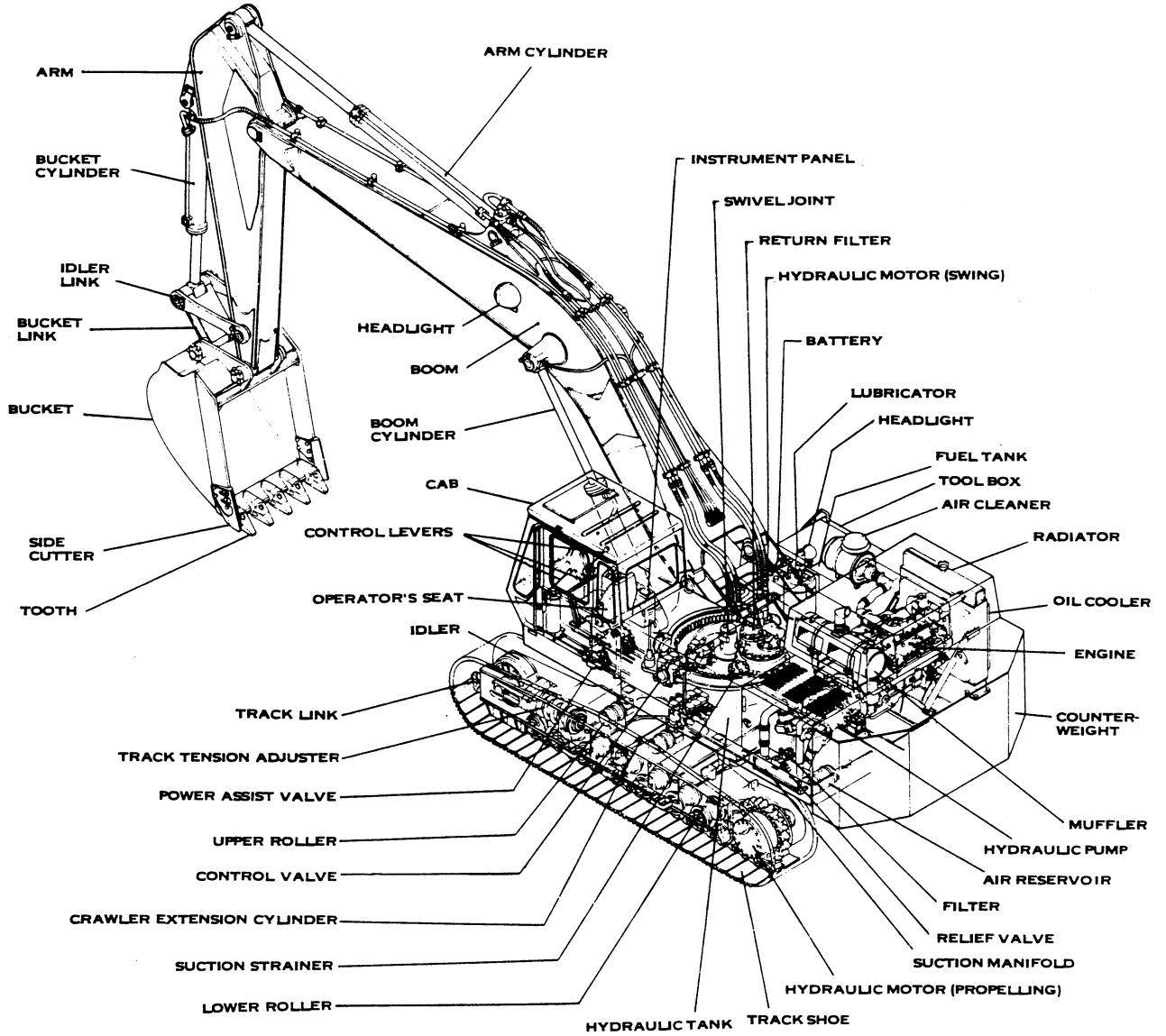

L-1749

1.2 LOADING SHOVEL

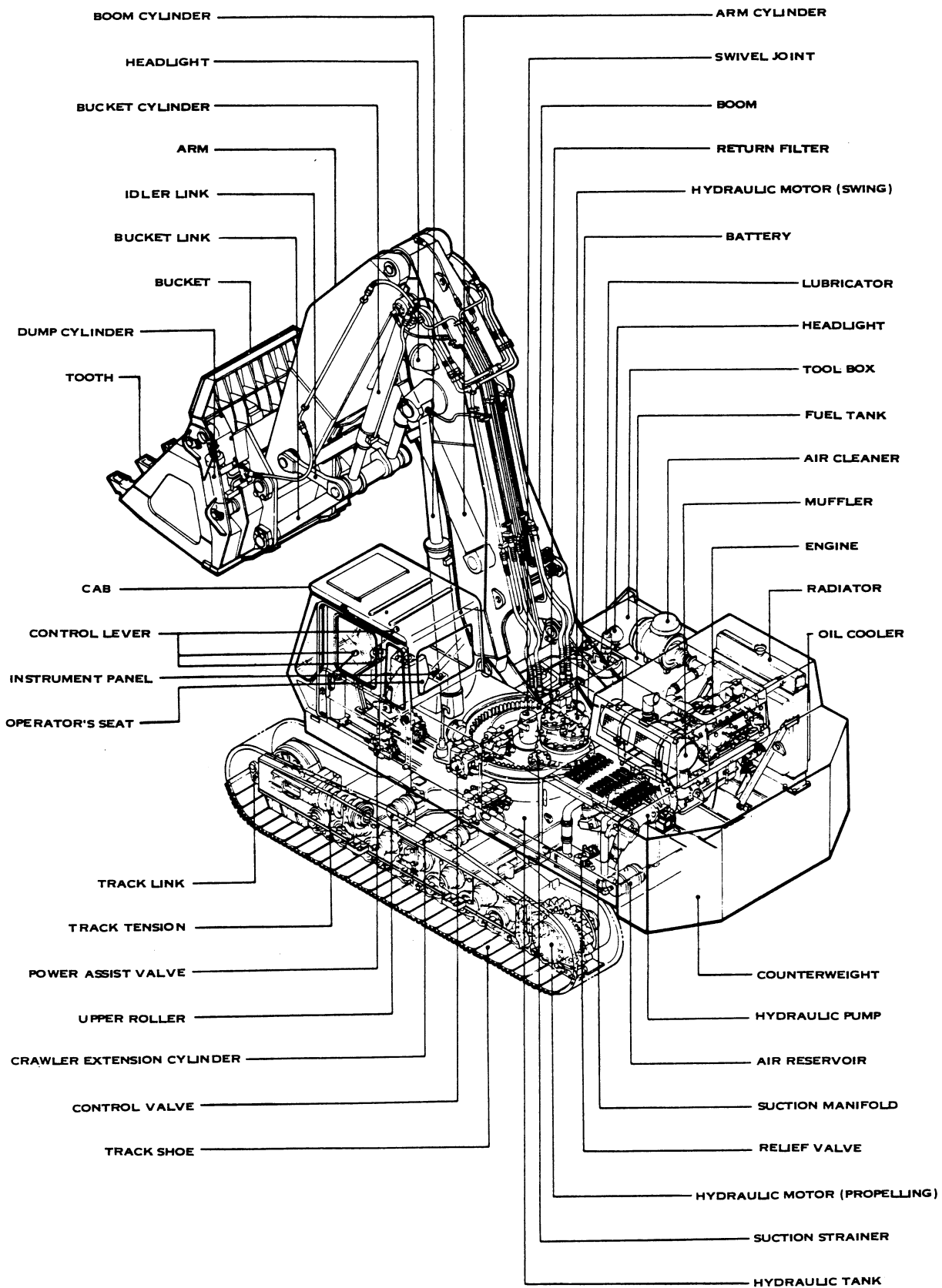

2. MACHINE DIMENSIONS (COMPLETE MACHINE)

2.1 BACKHOE (With 3.2m Arm, 2.7m Arm)

2.1~2.3 [L-60103~60216
LR-0117~0142

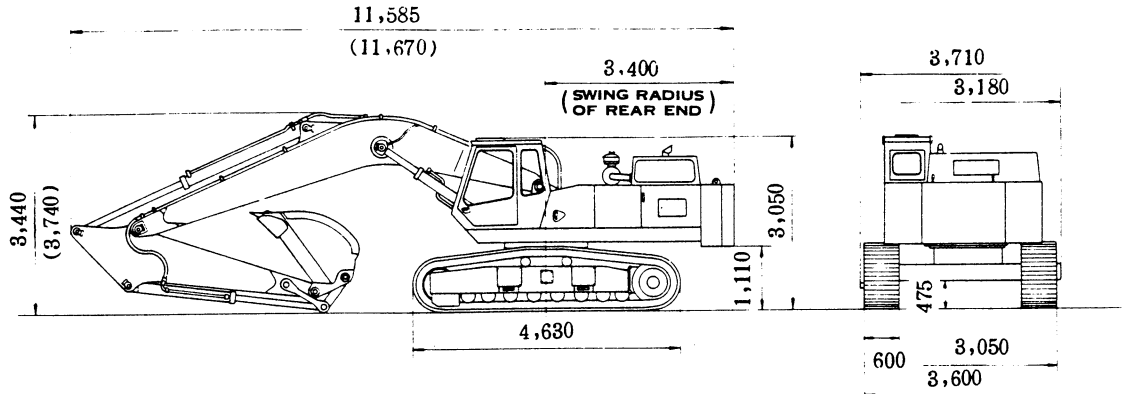

L-1322

NOTE: Dimensions in parentheses are those of backhoe with 2.7m arm.

2.2 BACKHOE (With 4.8m Arm)

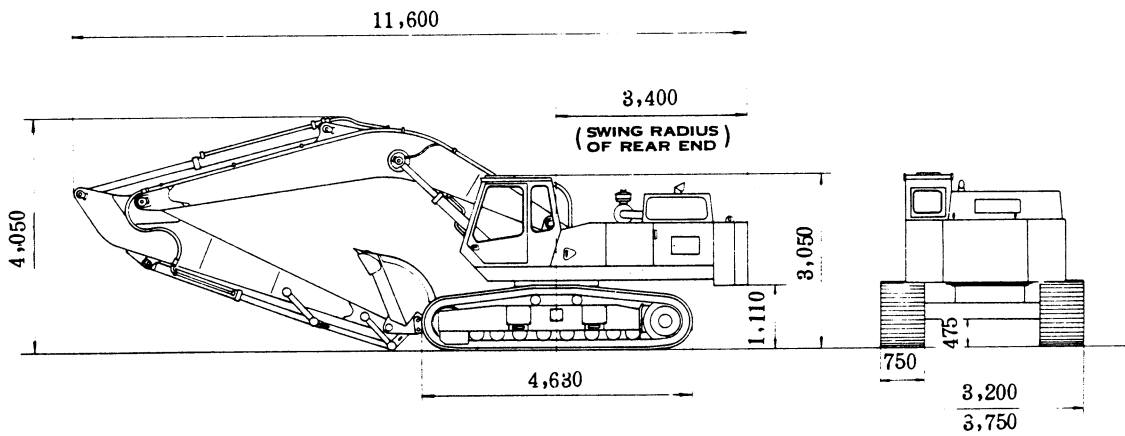

L-1324

2.3 LOADING SHOVEL

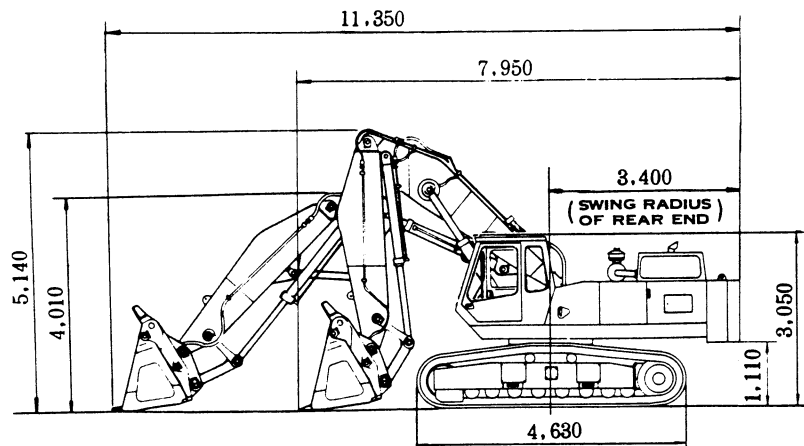

2.4 BACKHOE (With 3.2m Arm, 2.7m Arm)

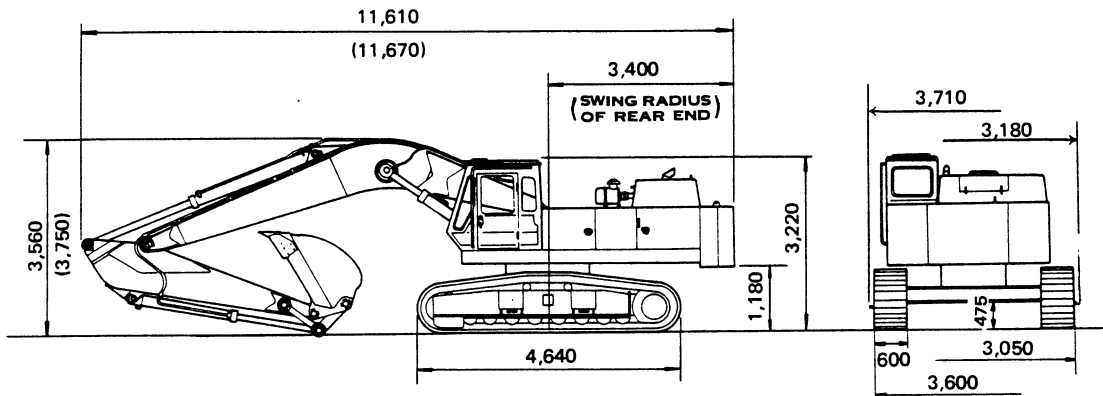

L-1750

NOTE: Dimensions in parentheses are those of backhoe with 2.7m arm.

2.5 BACKHOE (With 4.8m Arm)

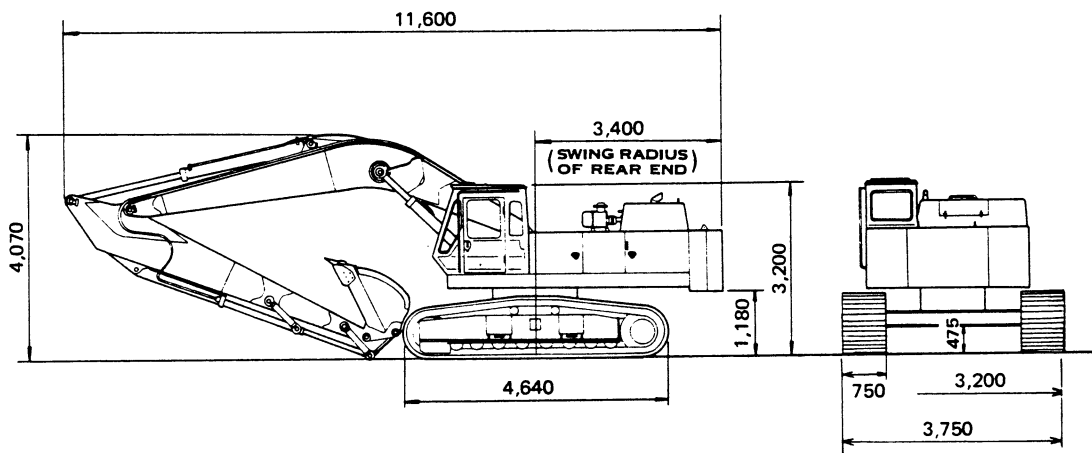

L-1751

2.6 LOADING SHOVEL

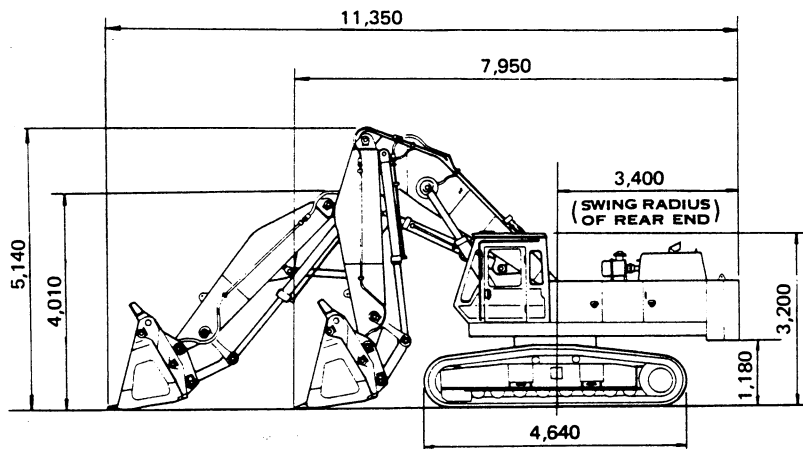

L-1752

3. PERFORMANCE

3.1 SPEED AND GRADEABILITY

3.1~3.3 [L-60103~60216
LR-0117~0142

	With 3.2m Arm	With 4.8m Arm	With Loading Shovel
Swing Speed	6.0rpm	←	←
Propelling Speed	3.2km/hr	←	←
Gradeability	58% (30°)	←	←

3.2 WEIGHT AND GROUND PRESSURE

Fully Equipped Weight	36,200kg	36,800kg	38,660kg
Ground Pressure	0.74kg/cm ²	0.62kg/cm ²	0.80kg/cm ²
(Width of Shoes)	(600mm)	(750mm)	(600mm)

3.3 HYDRAULIC COMPONENTS

Hydraulic Pump	3 – Variable Displacement Axial Piston Pump
Hydraulic Motor (Swing)	Radial Piston Motor
Hydraulic Motor (Propel)	2 – Axial Piston Motor
Control Valve	4 Spools · 3 Spools · 1 Spool
Cylinder (Boom, Arm, Bucket)	Double Acting Type Cylinders
Return Filter	Paper Type with Safety Valve
Oil Cooler	Forced Air-cooled Type

3.4 SPEED AND GRADEABILITY

	With 3.2m Arm	With 4.8m Arm	With Loading Shovel
Swing Speed	6.0rpm	←	←
Propelling Speed	3.2km/hr	←	←
Gradeability	58% (30°)	←	←

3.5 WEIGHT AND GROUND PRESSURE

Fully Equipped Weight	38,700kg	39,300kg	40,400kg
Ground Pressure	0.80kg/cm ²	0.65kg/cm ²	0.83kg/cm ²
(Width of Shoes)	(600mm)	(750mm)	(600mm)

3.6 HYDRAULIC COMPONENTS

Hydraulic Pump	3 – Variable Displacement Axial Piston Pump
Hydraulic Motor (Swing)	Radial Piston Motor
Hydraulic Motor (Propel)	2 – Axial Piston Motor
Control Valve	5 Spools · 3 Spools · 1 Spool
Cylinder (Boom, Arm, Bucket)	Double Acting Type Cylinders
Return Filter	Paper Type with Safety Valve
Oil Cooler	Forced Air-cooled Type

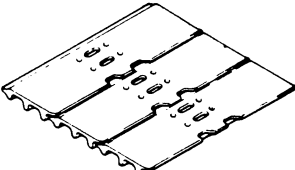

4. TYPE OF SHOES

Shape	Width of Track Shoe (mm)	Overall Width of Crawler (mm)
Grouser (Equal Height) 	600	3,710 (*Frame)
	750	3,750
	900	3,900

5. TYPE AND COMBINATION OF ATTACHMENTS

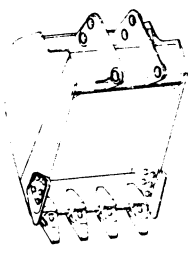
5.1 TYPE OF BUCKETS

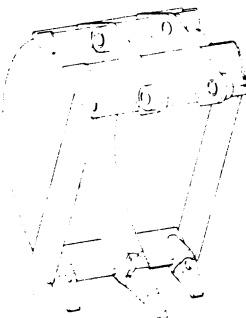
Hoe Bucket  L-1753	Heaped Capacity (m ³)	Use	Outer Width (mm)		Number of Tooth	Side Cutters	Weight (kg)
			With Side Cutters	Without Side Cutters			
	1.8	For Loading	1,550	1,470	5	Yes	1,660
	1.6	For 2.7m Arm	1,400	1,320	5	Yes	1,560
	1.6	For Loading	1,490	1,410	5	Yes	1,540
	1.4	For Heavy Duty Digging	-	1,270	4	No	1,470
	1.4	For 3.2m Arm	1,340	1,260	5	Yes	1,460
	1.0	For 4.8m Arm	1,300	1,230	4	Yes	1,110

Ripper Bucket  L-1754 Capacity : 1.2m ³ Outer Width : 1,200mm Side Cutter : None Number of Tooth : 1 + 2 Weight : 1,940kg	Ripper  L-1756 Weight : 900kg
---	--

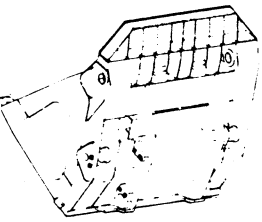
Loading Shovel Bucket (Bottom Dump)  L-1755 Capacity : 2.0m ³ Outer Width : 1,860mm Number of Tooth : 6 Weight : 2,760kg	
--	--

5.2 COMBINATION OF ATTACHMENTS

Type of Buckets	Heaped Capacity (m ³)	Use	Applicable Arm		
			2.7m Arm	3.2m Arm	4.8m Arm
Hoe Bucket	1.8	For Loading	△	×	×
	1.6	For 2.7m Arm	⊙	×	×
	1.6	For Loading	△	△	×
	1.4	For Heavy Digging	○	○	×
	1.4	For 3.2m Arm	○	⊙	×
	1.0	For 4.8m Arm	×	×	⊙
Ripper Bucket	1.2	For Heavy Duty Digging	○	○	×
Ripper	Digging Force = 19.3ton		○	○	×

NOTE

- Width means the distance between the side cutters for the bucket with the side cutters. For the bucket without side cutters, the distance between both outside edges of the bucket.
- The bucket for 4.8m arm and the buckets for other arms are not interchangeable because of differences in the bucket mounting part of each arm end.
- Meaning of Symbols:
 - ⊙ means standard combination with the applicable arms.
 - means usable.
 - △ means usable for loading only.
 - × means not usable.

6. WORKING RANGE OF ATTACHMENTS

6.1 BACKHOE (With 3.2m Arm, 2.7m Arm)

6.1~6.2 L-60103~60216
LR-0117~0142

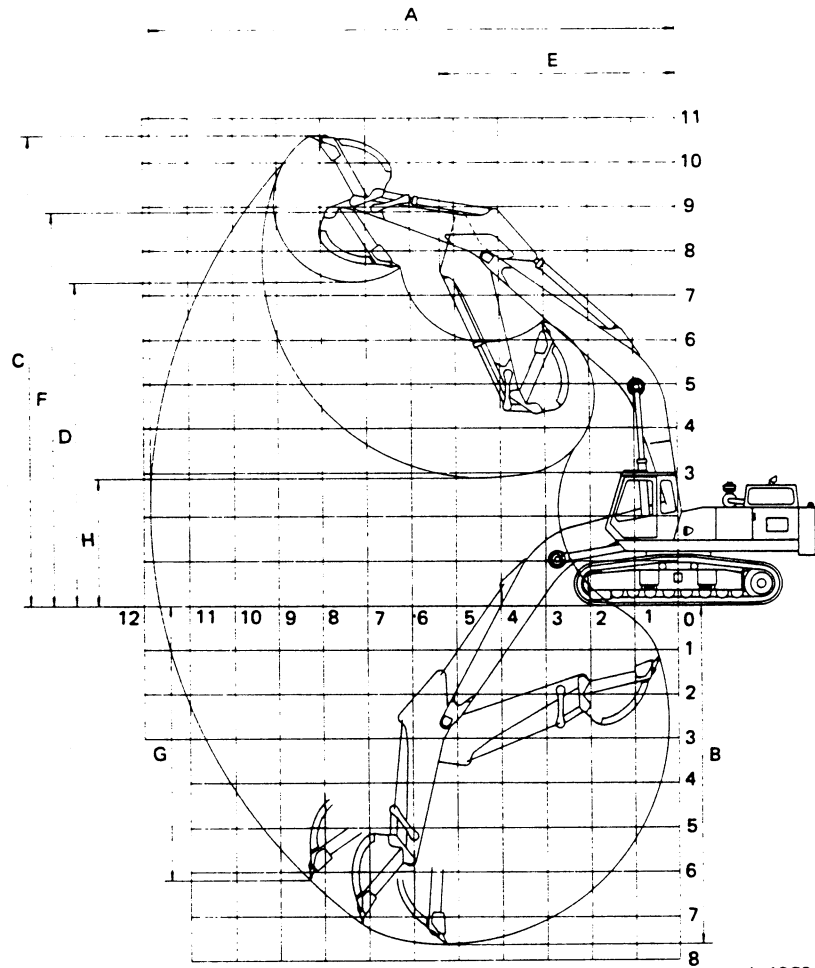

L-1323

Unit: m

Item	Type of Arm Type of Bucket	With Arm "S" (3.2m)			With Short Arm (2.7m)
		1.6m ³ Bucket 1.4m ³ Bucket	Ripper Bucket	Ripper	1.6m ³ Bucket
A: Max. Digging Reach		11.82	11.64	11.64	11.45
B: Max. Digging Depth		7.65	7.46	7.46	7.19
C: Max. Digging Height		10.61	10.50	10.36	10.49
D: Max. Dumping Clearance		7.30	7.48	—	7.17
E: Min. Swing Radius		5.30	←	←	5.45
F: Height at Min. Swing Radius		8.91	←	←	9.04
G: Max. Vertical Digging Depth		6.16	—	—	5.12
H: Min. Dumping Clearance		2.89	3.07	—	3.34

6.2 BACKHOE (With 4.8m Arm)

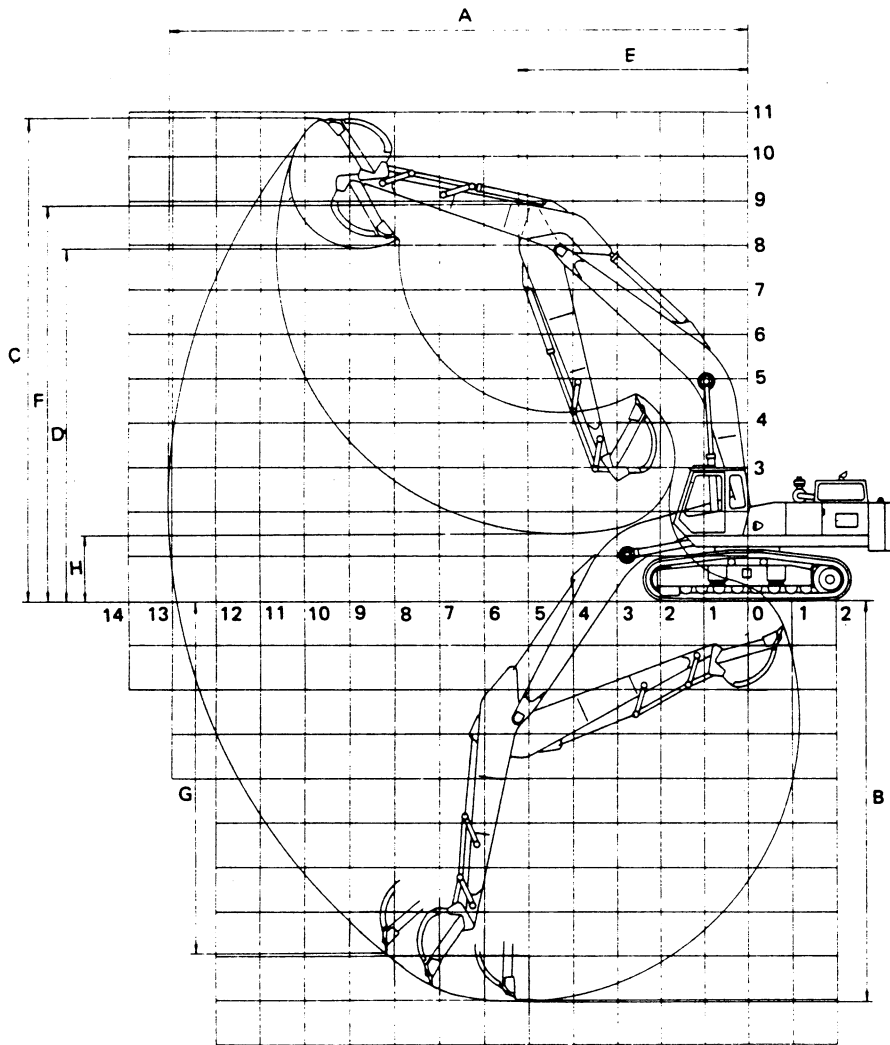

L-1325

		Unit: m
Item	Type of Bucket	1.0m ³ Bucket
A:	Max. Digging Reach	13.07
B:	Max. Digging Depth	9.04
C:	Max. Digging Height	10.87
D:	Max. Dumping Clearance	7.94
E:	Min. Swing Radius	5.20
F:	Height at Min. Swing Radius	8.91
G:	Max. Vertical Digging Depth	7.92
H:	Min. Dumping Clearance	1.49

6.3 BACKHOE (With 3.2m Arm, 2.7m Arm)

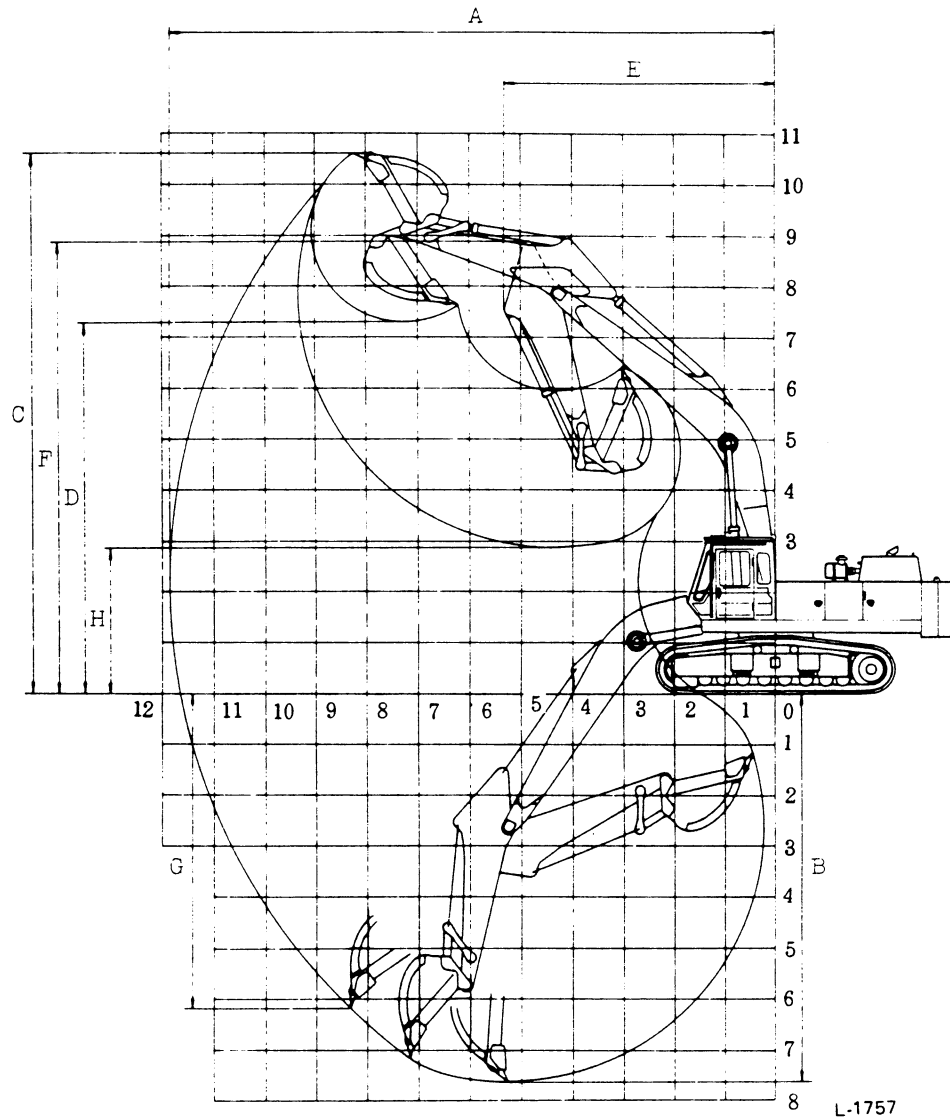

L-1757

Unit: m

Item	Type of Arm Type of Bucket	3.2m Arm			2.7m Arm
		1.4m ³ Bucket 1.6m ³ Bucket	Ripper Bucket	Ripper	1.6m ³ Bucket 1.8m ³ Bucket
A: Max. Digging Reach		11.82	11.64	11.64	11.45
B: Max. Digging Depth		7.63	7.45	7.45	7.18
C: Max. Digging Height		10.63	10.39	10.53	10.59
D: Max. Dumping Clearance		7.32	7.50	—	7.19
E: Min. Swing Radius		5.30	←	←	5.46
F: Height at Min. Swing Radius		8.95	←	←	9.06
G: Max. Vertical Digging Depth		6.12	—	—	5.64
H: Min. Dumping Clearance		2.91	3.09	—	3.36

6.4 BACKHOE (With 4.8m Arm)

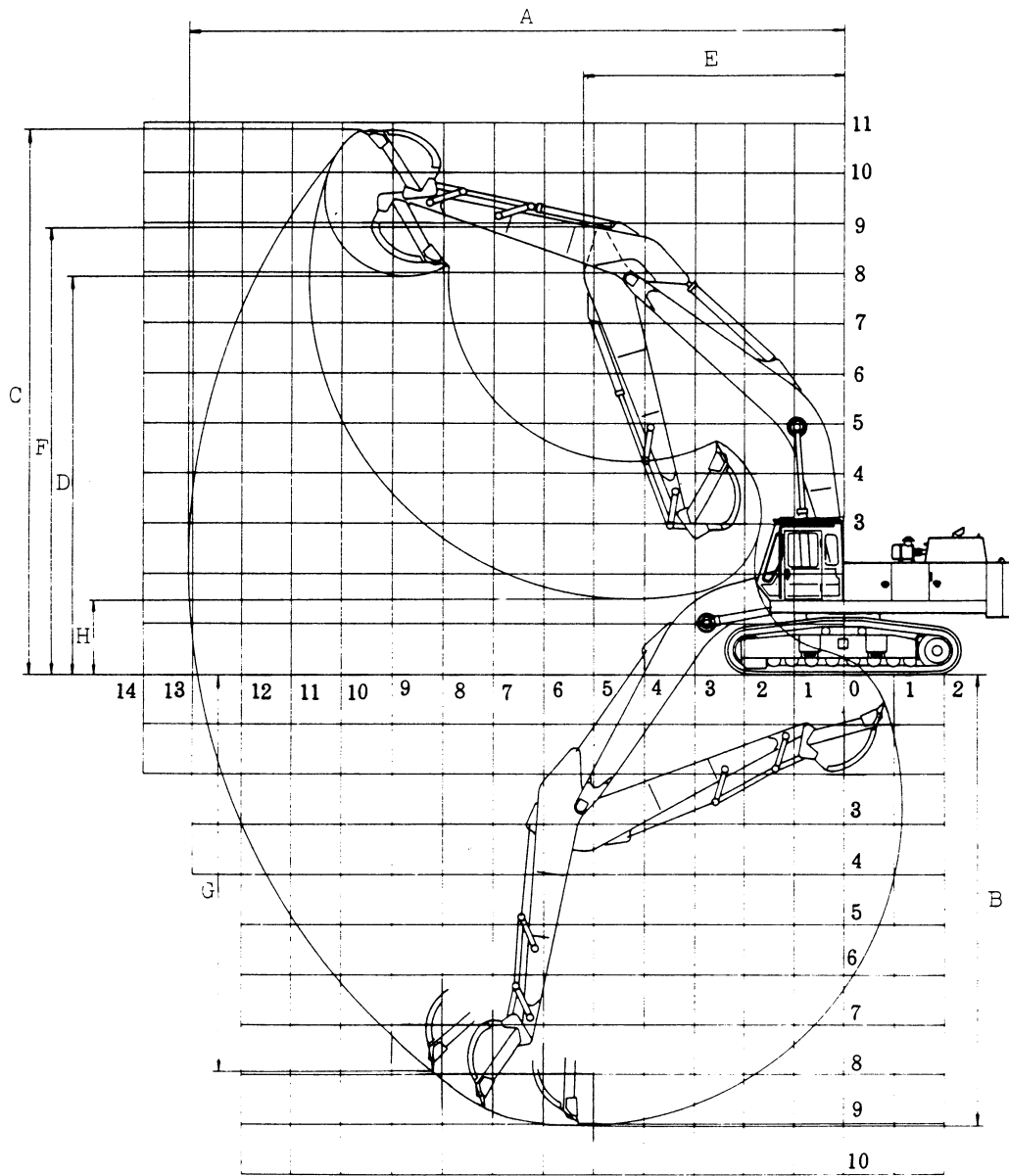

L-1758

Item	Type of Bucket	Unit: m
	1.0m ³ Bucket	
A: Max. Digging Reach		13.07
B: Max. Digging Depth		9.02
C: Max. Digging Height		10.83
D: Max. Dumping Clearance		7.97
E: Min. Swing Radius		5.22
F: Height at Min. Swing Radius		8.92
G: Max. Vertical Digging Depth		7.40
H: Min. Dumping Clearance		1.51

6.5 LOADING SHOVEL

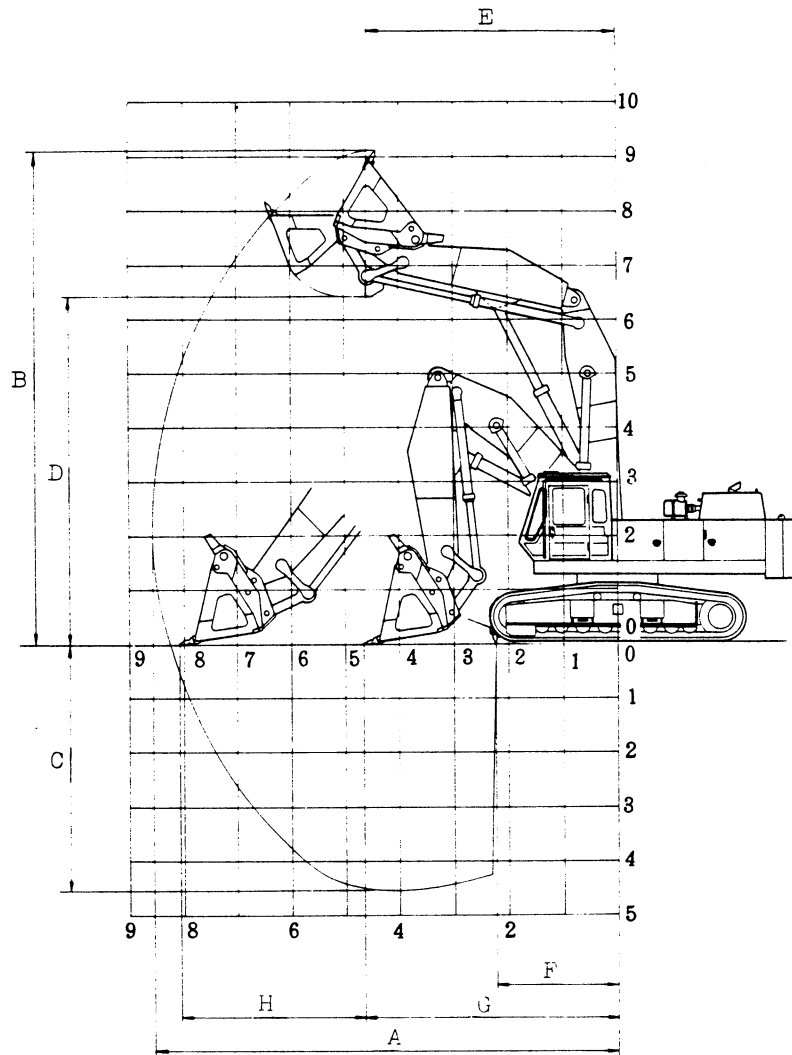

L-1759

Item	Type of Bucket	Unit: m
	2.0m ³ Bucket	
A: Max. Digging Reach		8.56
B: Max. Digging Height		9.11
C: Max. Digging Depth		4.60
D: Max. Dumping Clearance		6.42
E: Radius at "D"		4.62
F: Min. Cutting Radius		2.22
G: Push-out Starting Radius		4.66
H: Horizontal Push-out Distance		3.39

6.6 BACKHOE (With 5m Arm)

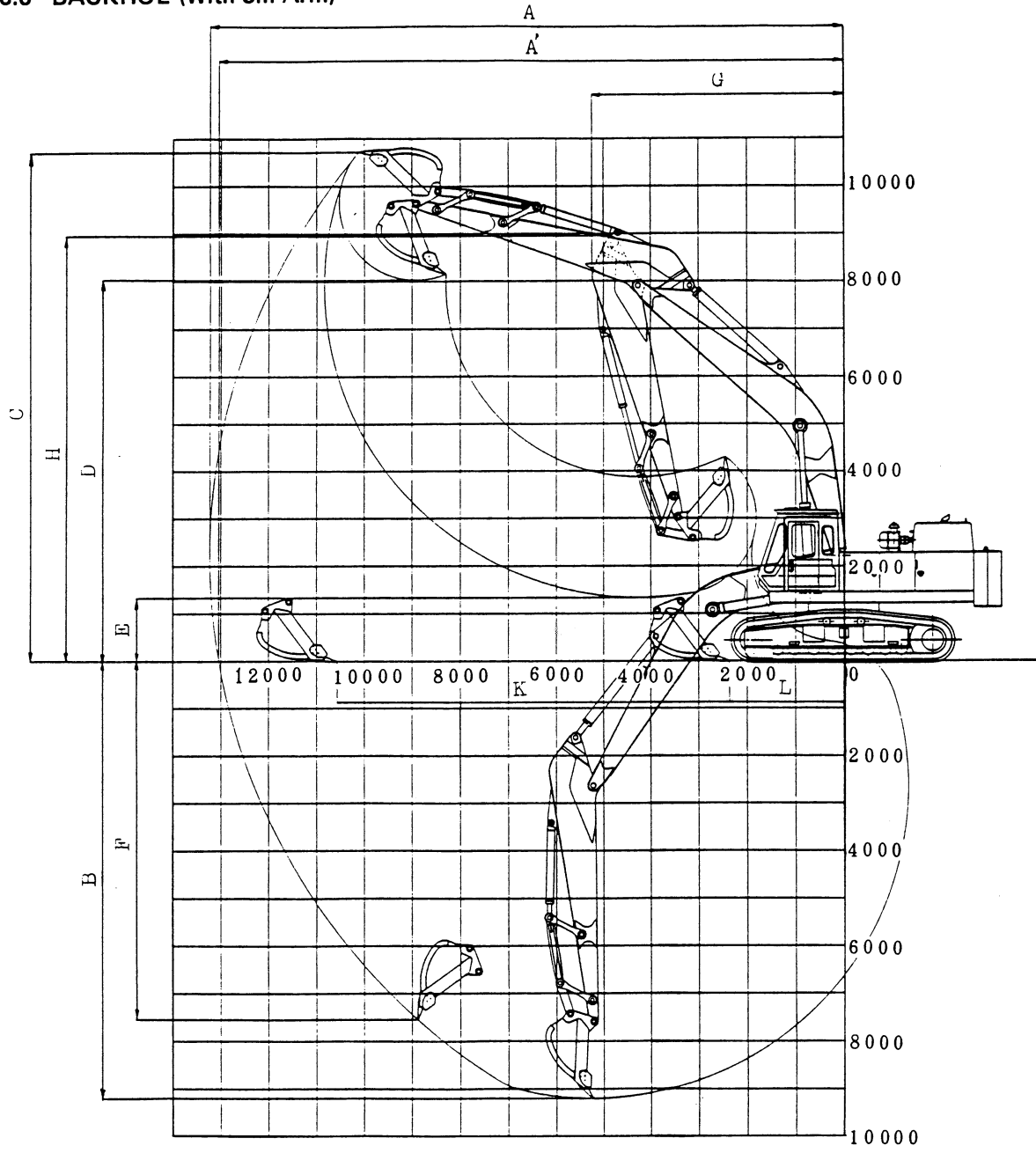

(Unit: m)

Mark	Item	5m Arm	
A	Max. Digging Reach	13.2	
A'	Max. Reach at Ground Level	13.0	
B	Max. Digging Depth	9.1	
C	Max. Digging Height	10.9	
D	Max. Dumping Clearance	8.1	
E	Min. Dumping Clearance	1.4	
F	Max. Vertical Digging Depth	7.6	
G	Min. Swing Radius	5.2	
H	Height at Min. Swing Radius	9.0	
K	Horizontal Digging Distance	Stroke	8.2
		Min.	2.4
L	Bucket Capacity	1.0m ³	

7. LIFTING CAPACITY DIAGRAM

7.1 BACKHOE (With 2.7m Arm) 360°

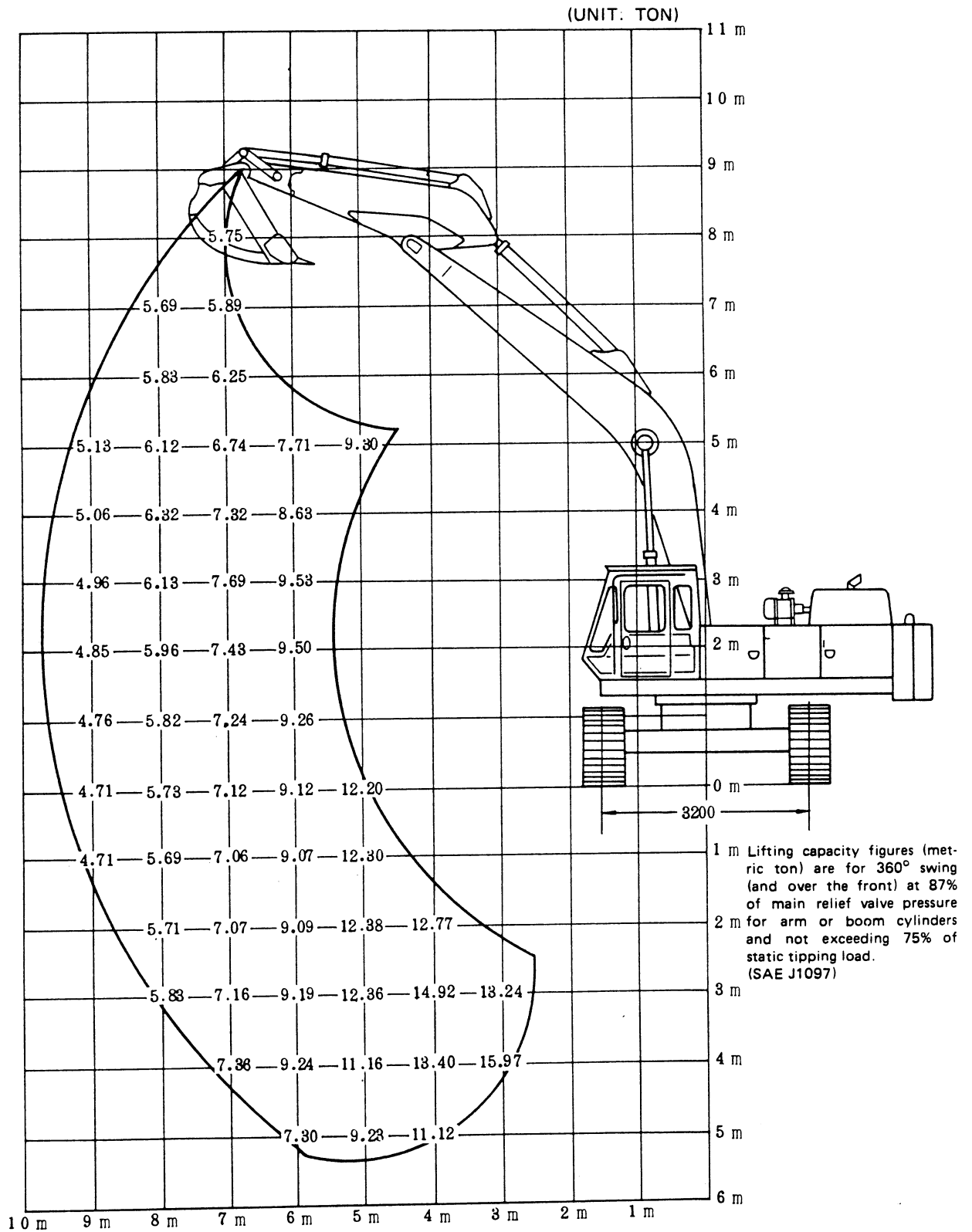

7.2 BACKHOE (With 3.2m Arm) 360°

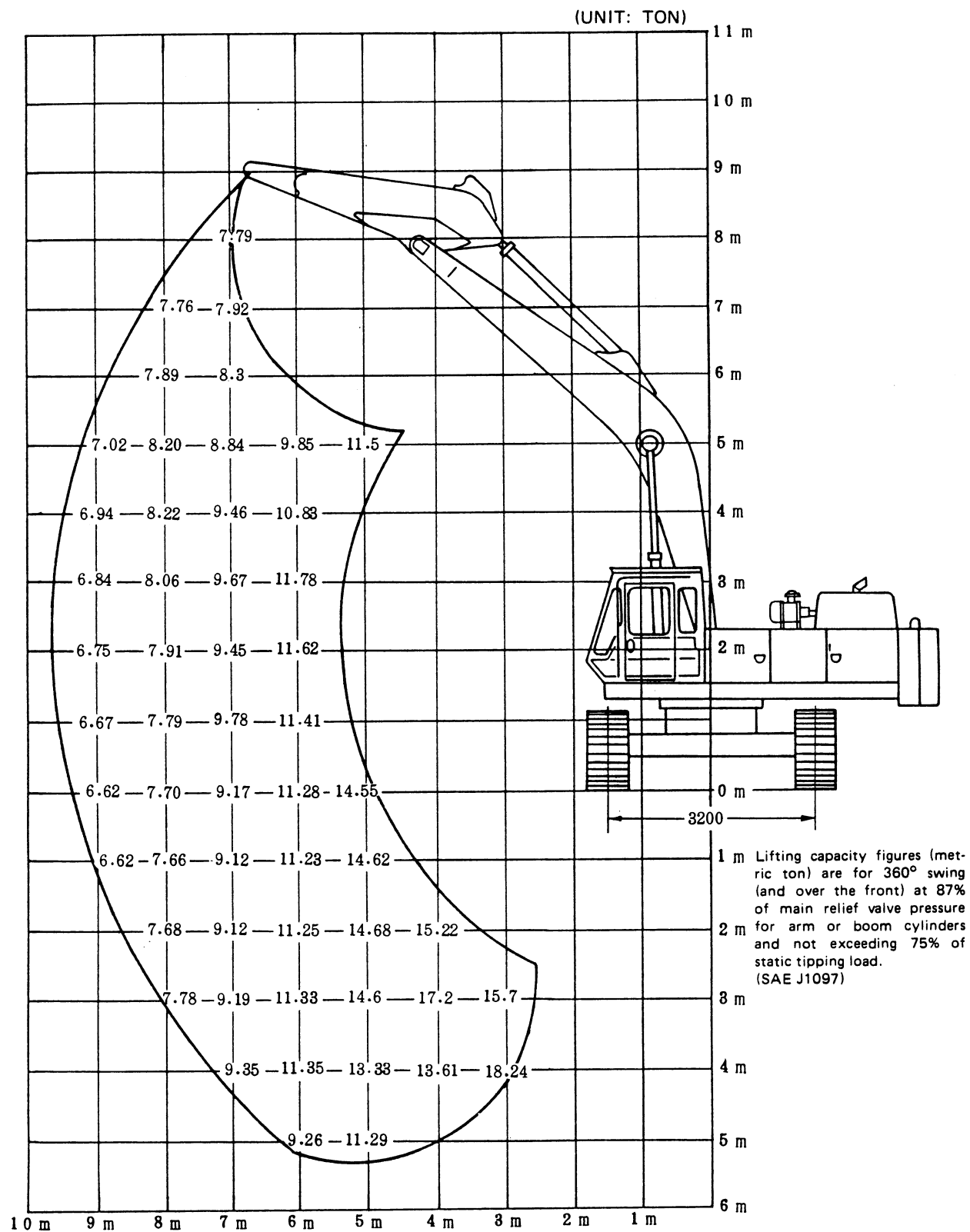

7.3 BACKHOE (With 3.2m Arm) 360°

(UNIT: TON)

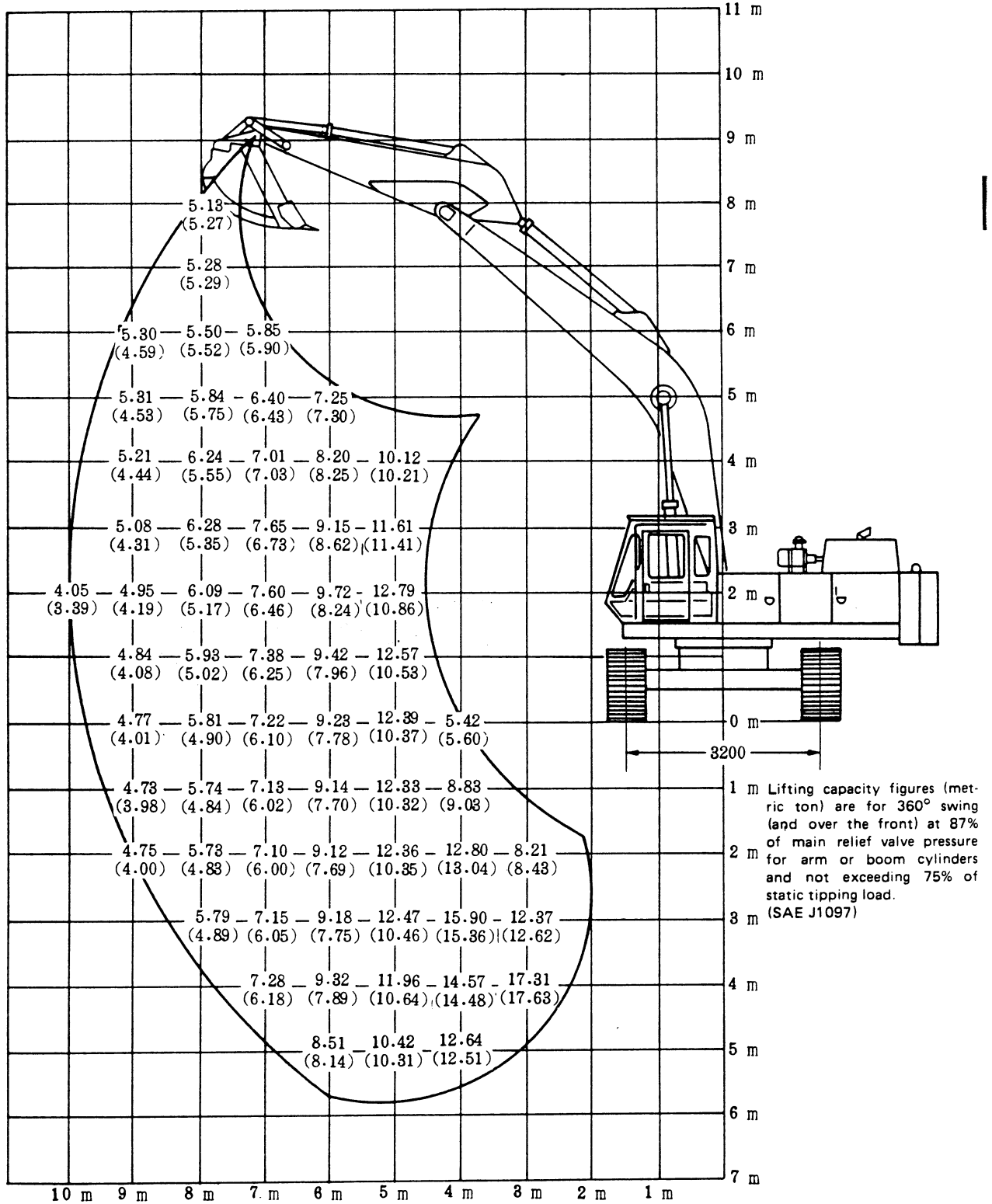

7.4 BACKHOE (With 3.2m Arm, Without Bucket) 360°

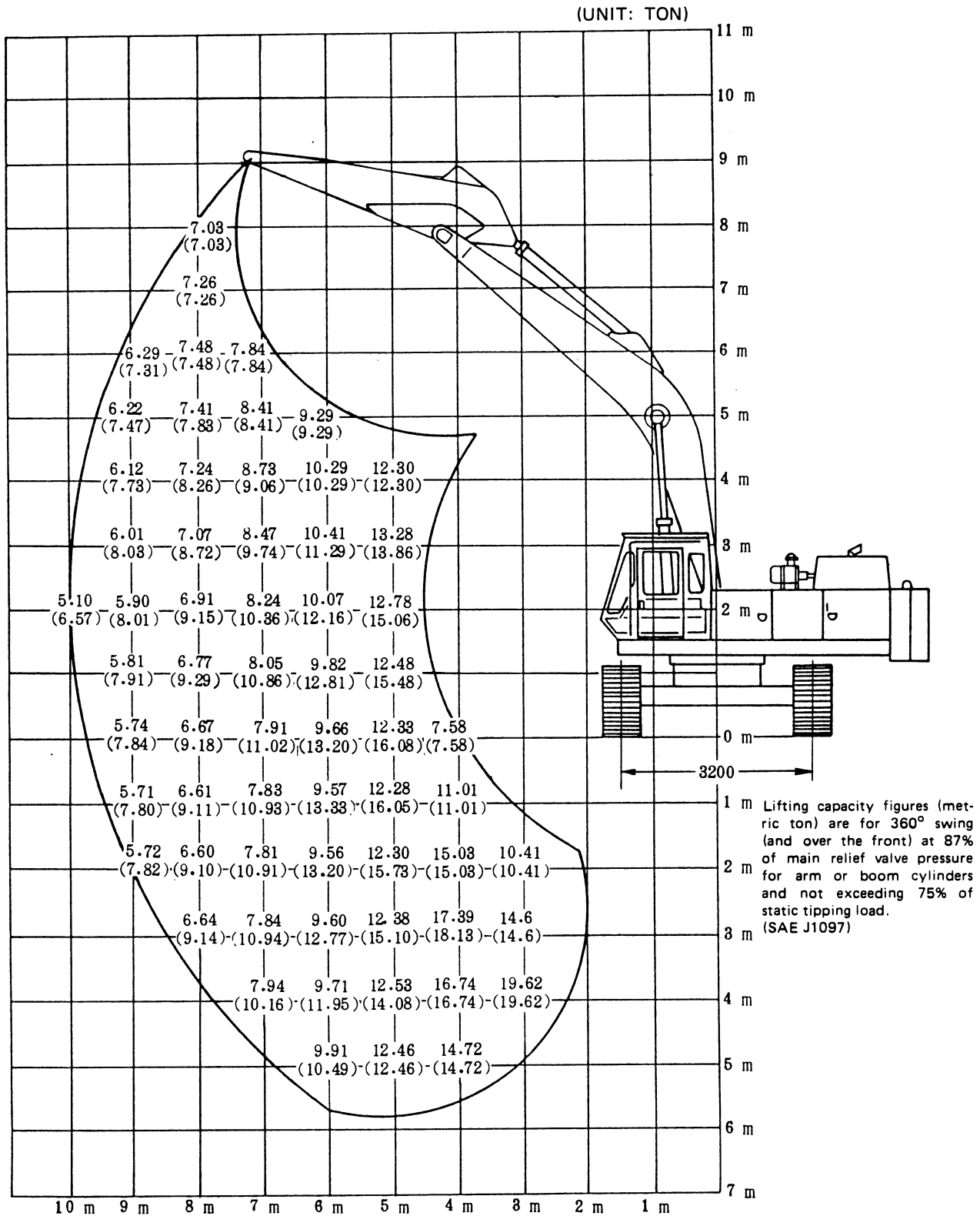

7.5 BACKHOE (4.8m Arm)

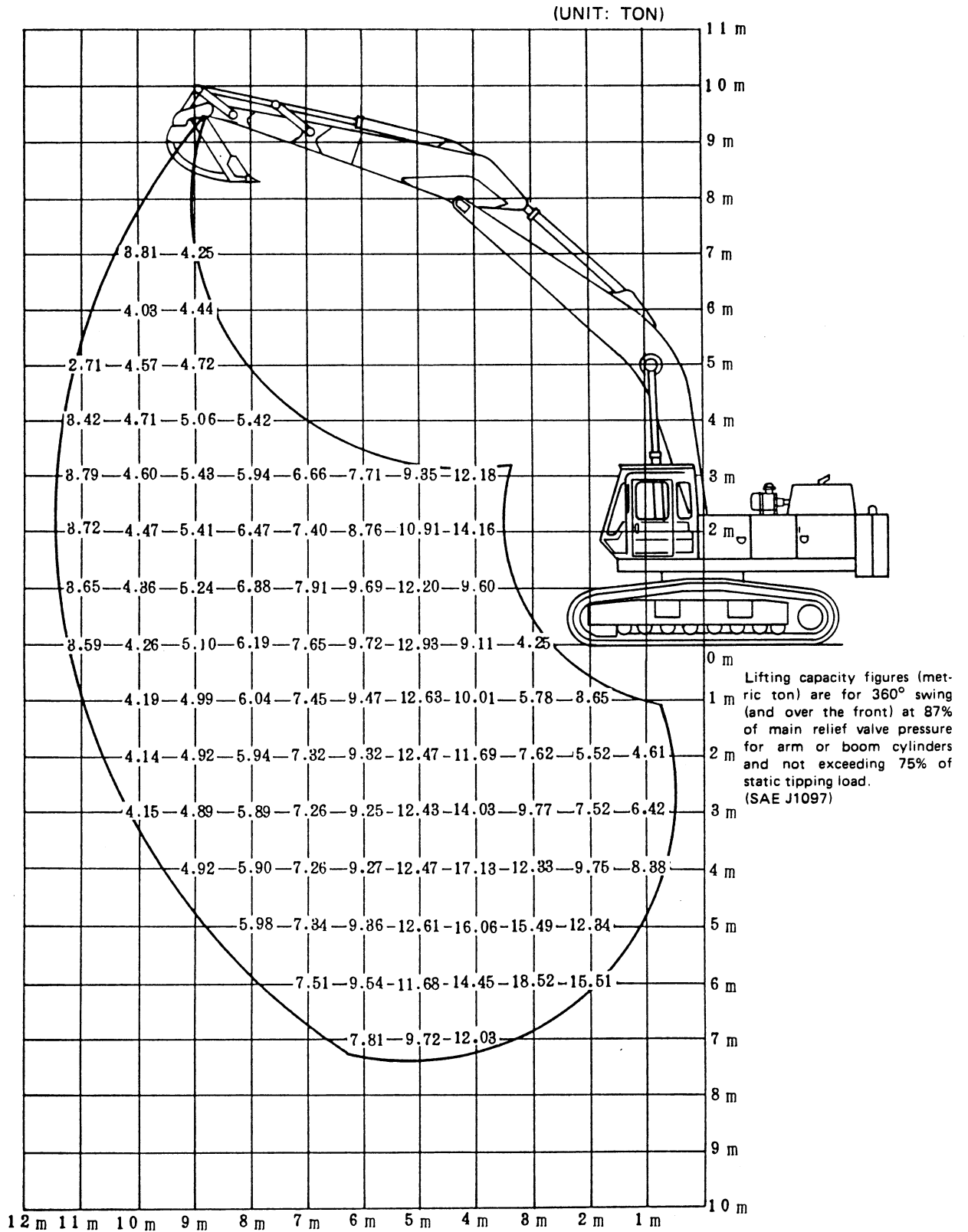

7.6 BACKHOE (With 4.8m, Without Bucket) 360°

(UNIT: TON)

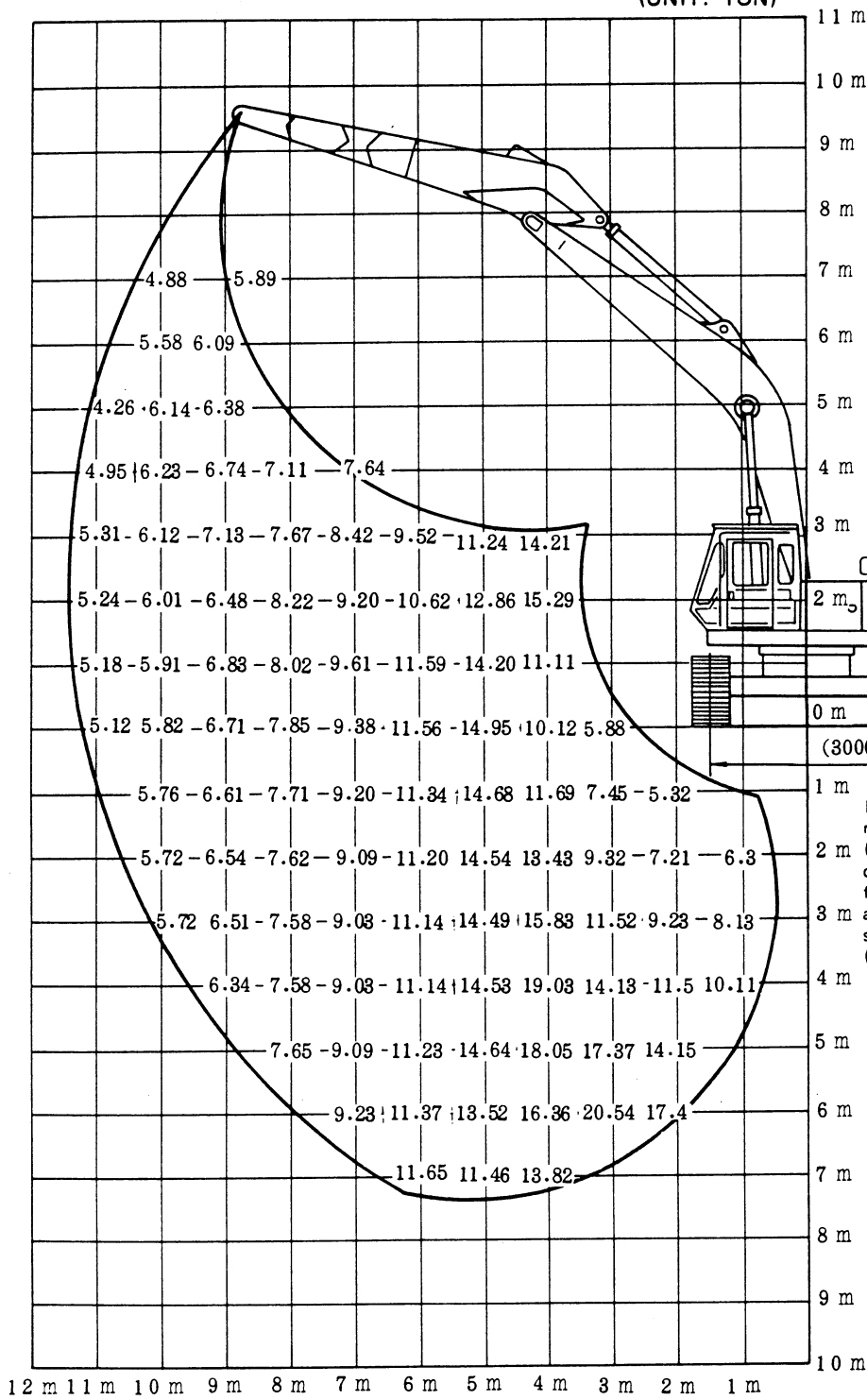

Lifting capacity figures (metric ton) are for 360° swing (and over the front) at 87% of main relief valve pressure for arm or boom cylinders and not exceeding 75% of static tipping load. (SAE J1097)

7.7 BACKHOE (With 5m Arm) 360°

(UNIT: TON)

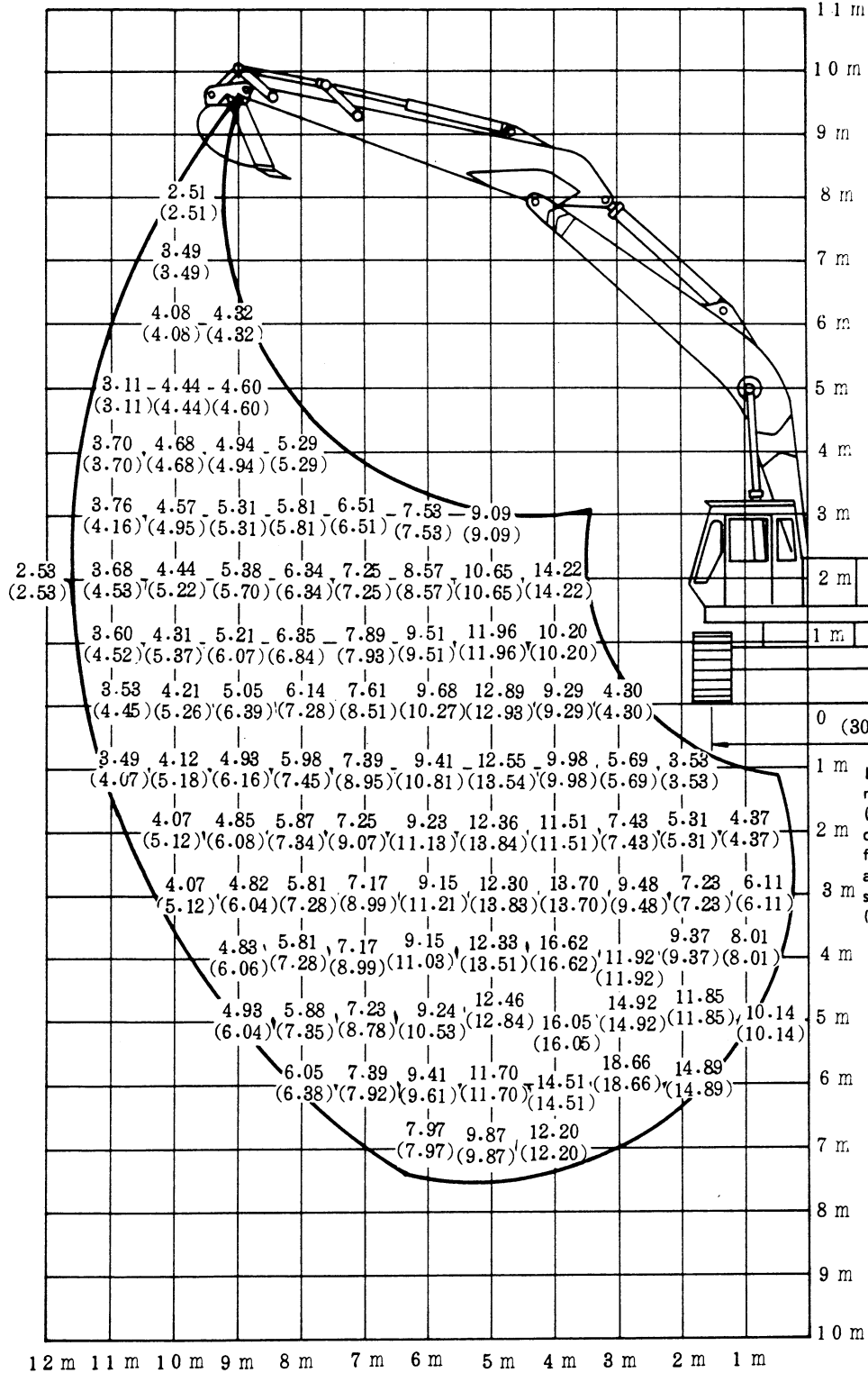

Lifting capacity figures (metric ton) are for 360° swing (and over the front) at 87% of main relief valve pressure for arm or boom cylinders and not exceeding 75% of static tipping load. (SAE J1097)

7.8 BACKHOE (With 5m Arm, Without Bucket) 360°

(UNIT: TON)

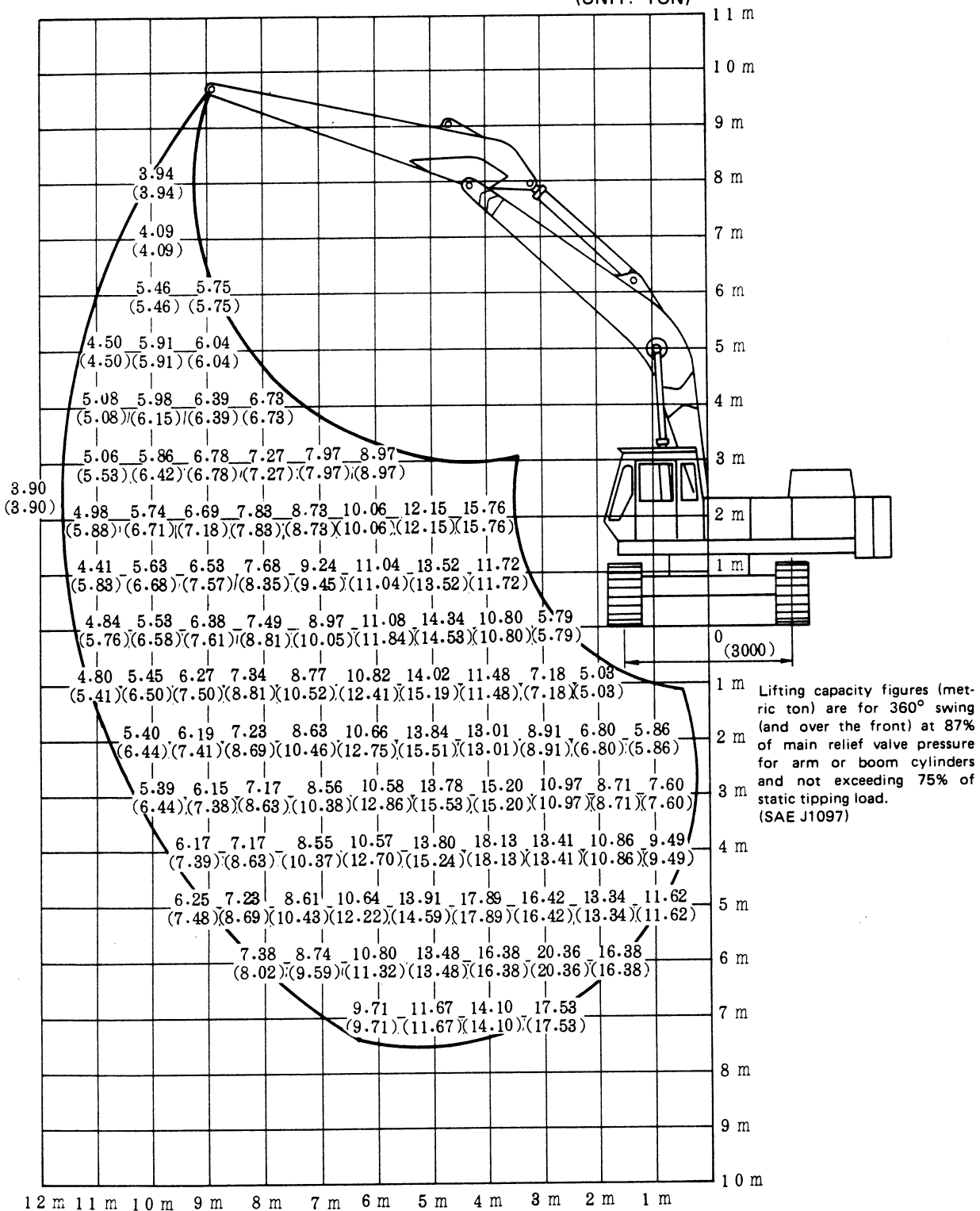

8. SPECIFICATIONS OF ENGINE

8.1 SPECIFICATIONS

Item	Type	8DC60C	8DC61C	8DC81C
Cycle		4	←	←
Cooling System		Water-cooled	←	←
Valve Mechanism		Overhead Valve Type	←	←
Combustion Chamber		Pre-combustion Type	←	Direct Injection Type
Number of Cylinders – Arrangement		8 – 90°V	←	←
Bore x Stroke	mm	135 x 130	←	←
Total Displacement	cc	14886	←	←
Compression Ratio		18	←	17
Compression Pressure		28kg/cm ² – 200rpm	←	←
Firing Order		1-2-7-3-4-5-6-8	←	←
Turning Direction (as view from fan side)		Right	←	←
Starting System		Cell Motor	←	←
Dry Weight	kg	1020	1120	1070
Rated Output	PS/rpm	214/1800	←	←
Max. Torque	kg·m/rpm	88/1300	←	←
Min. Revolution without Load (Low Idle)	rpm	450~500	550~600	←
Max. Revolution without Load (High Idle)	rpm	1870~1980	←	1930~1980
Starter		24V – 7.5KW	←	←
Generator		24V – 700W	←	←
Applicable Machines		L-60103~60134	L-60135~60216 LR-0117~0142	LR-0143~

8.2 PERFORMANCE CURVES (MITSUBISHI 8DC60C)

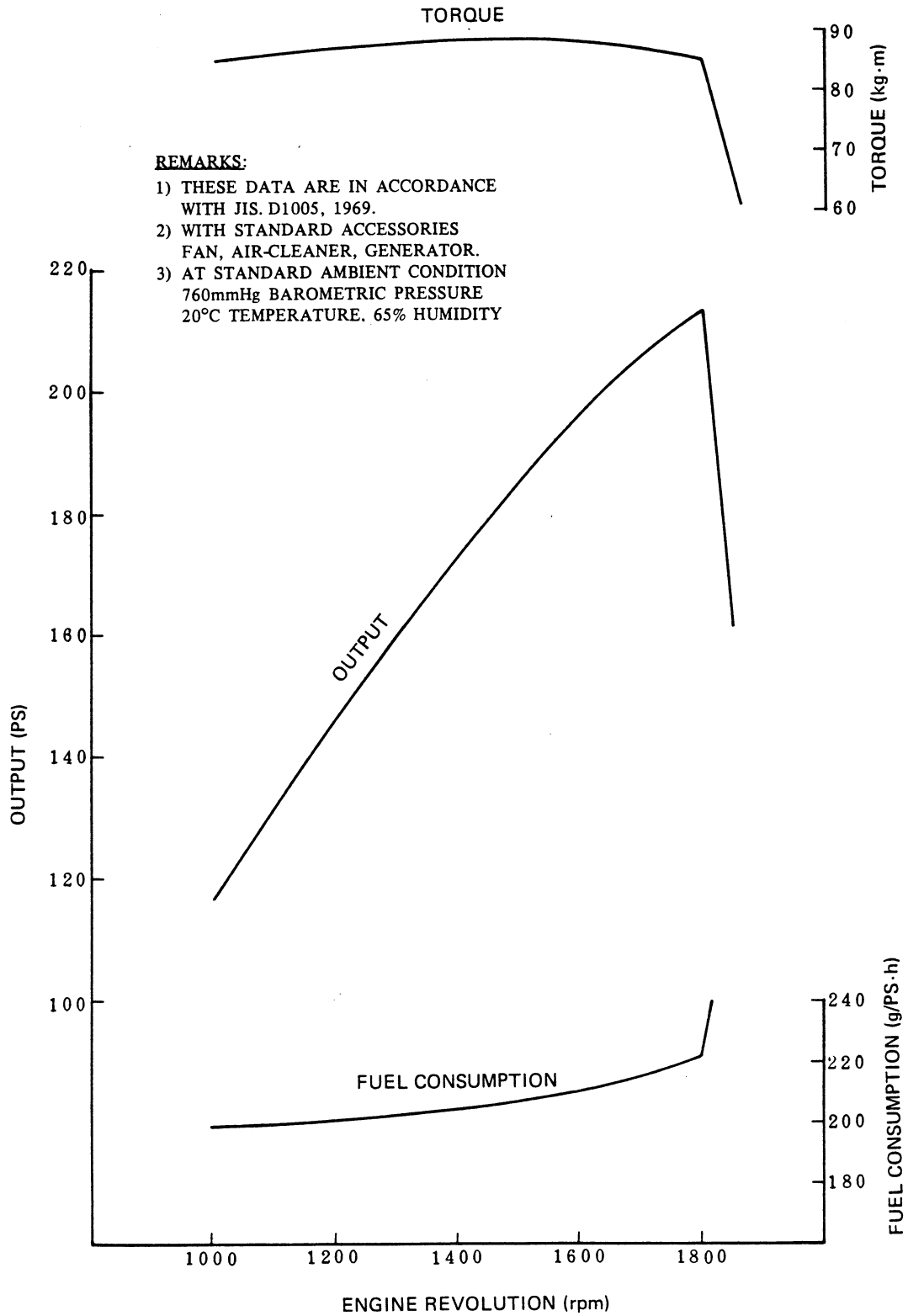

8.3 PERFORMANCE CURVES (MITSUBISHI 8DC61C)

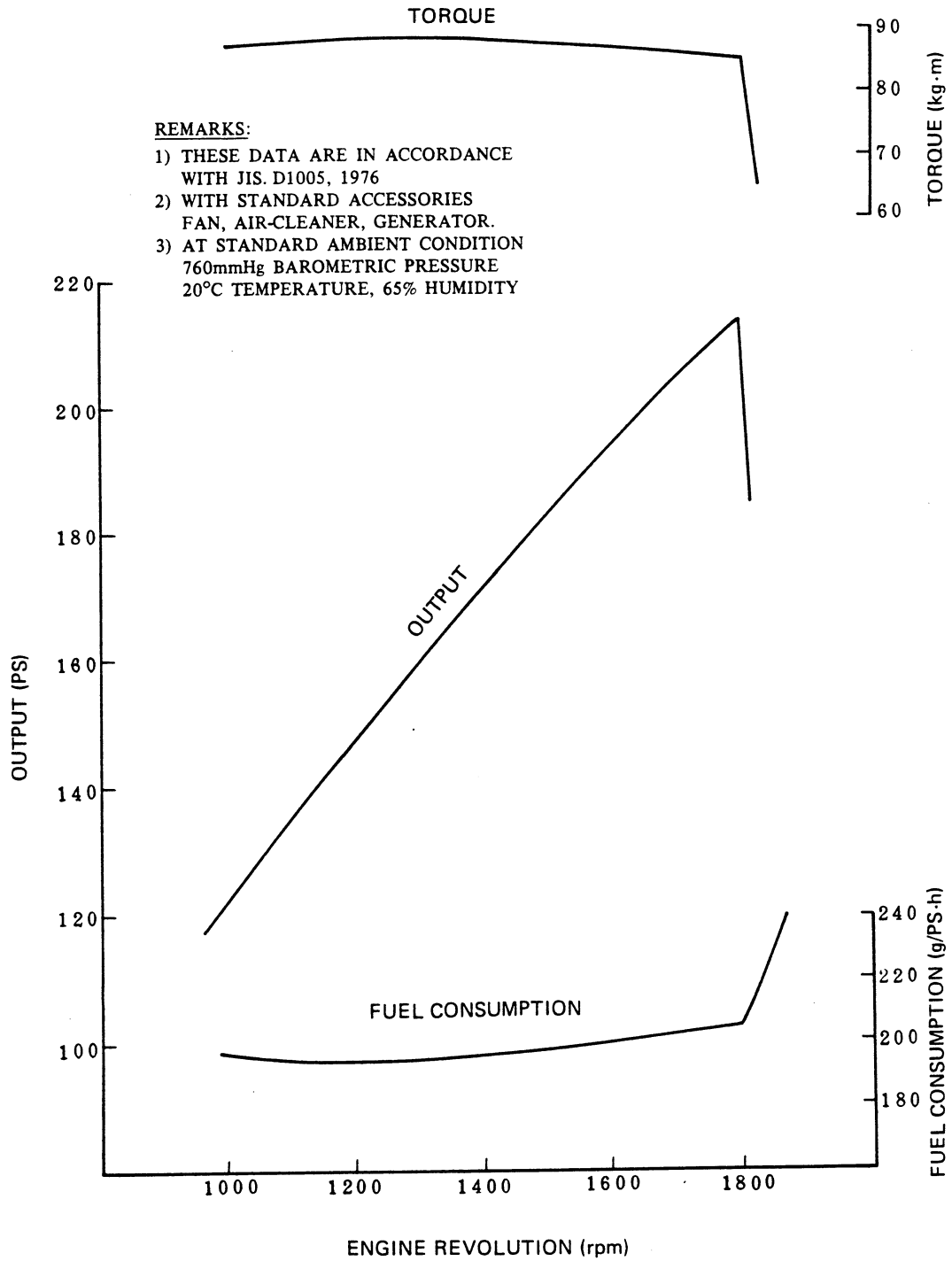

8.4 PERFORMANCE CURVES (MITSUBISHI 8DC81C)

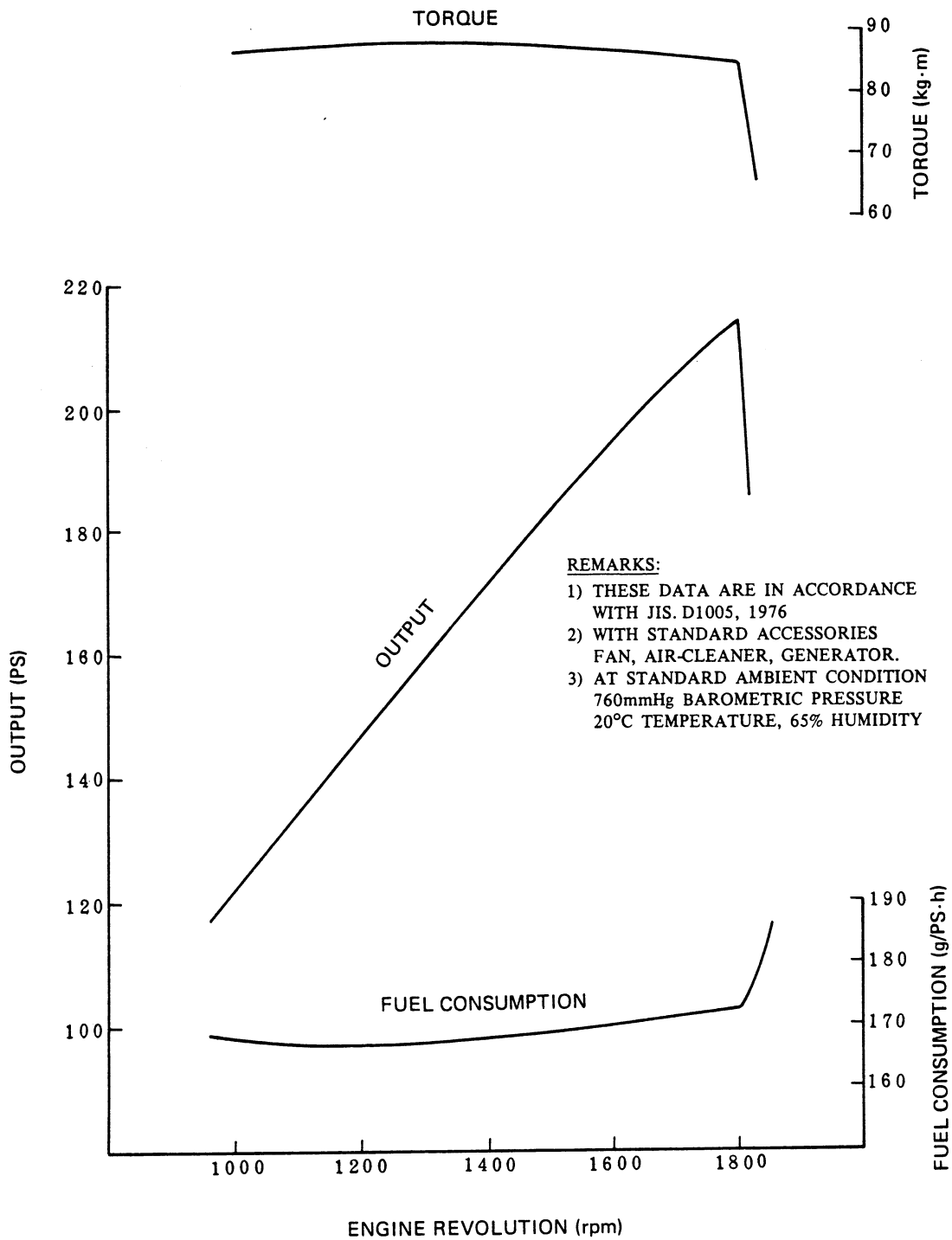



SHOP MANUAL SK14·K914

— OPERATION —

TABLE OF CONTENTS

1. OPERATION OF THE MACHINE	
1.1 Instrument Panel	1
1.2 Adjustment of Operator's Seat	3
1.3 Operator's Cab Windows	4
2. PRE-OPERATION CHECKS	5
3. NEW MACHINE PRECAUTIONS	5
4. STARTING AND STOPPING THE ENGINE	
4.1 Starting the Engine	6
4.2 Stopping the Engine	6
5. WARM-UP OPERATION	7
6. OPERATION	
6.1 Backhoe Attachment Operation	7
6.2 Face Shovel Operation	7
6.3 Loading Shovel Operation	7
6.4 Propel Operation	8
6.5 Swing Lock	8
7. OPERATION UNDER UNUSUAL CONDITIONS	11

Applicable Machines
L-60103~60216
LR-0117~

Revision	Date of Issue	Remarks
First edition	1983.12	120R

1. OPERATION OF THE MACHINE

The machine is divided in two halves – the upper and the lower.

The operator's cab is mounted on the upper at the left.

The attachment side is called the front and the engine is at the rear. On the lower, the propel motors are installed at the rear and the idler at the front.

1.1 INSTRUMENT PANEL

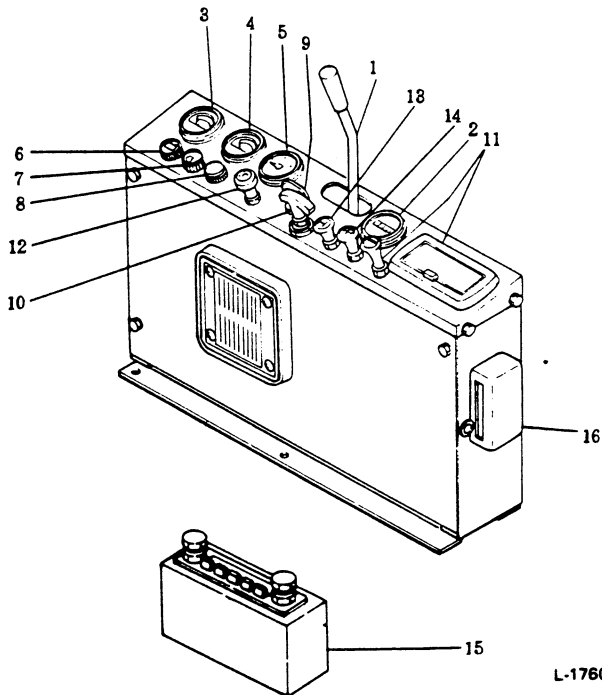

LR-0143~

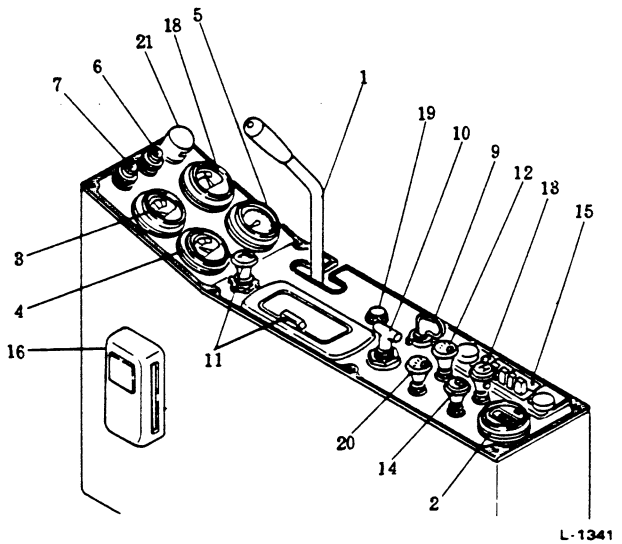

L-1341

L-60103~60216

LR-0117~0142

- | | | |
|------------------------------|---------------------------------|-------------------------|
| 1. ENGINE THROTTLE LEVER | 8. AIR HEATER INDICATOR | 15. CAR RADIO |
| 2. HOUR METER | 9. STARTER SWITCH | 16. FUSE BOX |
| 3. WATER TEMPERATURE GAUGE | 10. ENGINE STOP KNOB | 18. AMMETER |
| 4. OIL PRESSURE GAUGE | 11. ASH TRAY, CIGARETTE LIGHTER | 19. GLOW PLUG INDICATOR |
| 5. AIR PRESSURE GAUGE | 12. HEADLIGHT SWITCH | 20. ROOM LIGHT SWITCH |
| 6. BATTERY CHARGE ALARM LAMP | 13. HEATER SWITCH | 21. PANEL LIGHT |
| 7. OIL FILTER LAMP | 14. WIPER SWITCH | |

1. Engine Throttle Lever

This lever controls the speed of the engine. Pull the lever toward the operator to increase the engine speed and push the lever forward to reduce the engine speed to low idling.

2. Hour Meter

This meter shows the total running time of the engine.

3. Water Temperature Gauge

This gauge shows the temperature of the engine cooling water. The green zone shows the normal operating temperature.

4. Oil Pressure Gauge

This gauge shows the pressure of the lubricating oil in the engine. The green zone shows the normal operating pressure.

CAUTION

If there is no pressure build-up within 15 seconds after starting the engine, stop the engine immediately and check the lubricating oil system by referring to the Engine Manual.

5. Air Pressure Gauge

This gauge shows the pressure of the air in the hydraulic oil tank. After the engine started, confirm that the air pressure reading ranges between 0.5kg/cm² and 1.0kg/cm². When the pressure is below 0.5kg/cm², wait until the pressure will rise to the proper pressure.

6. Battery Charge Alarm Lamp

This is lit when the starter switch remains in the "ON" position after the engine is stopped. This will also come on when there is trouble in the charging circuit.

7. Oil Filter Lamp

This lamp lights when the engine oil filter clogs.

8. Air Heater Indicator

This indicates the condition of the engine air intake heater. This indicator will glow red after the engine starter switch is turned to the "HEAT" position.

9. Starter Switch

This is the engine starting switch. To start the engine, see the section "STARTING AND STOPPING THE ENGINE."

10. Engine Stop Knob

Pull to stop the engine.

11. Ash Tray, Cigarette Lighter

12. Headlight Switch

This switch is for turning on the headlights.

13. Heater Switch

This switch has three steps.

1st step : Low Heat

2nd step: Medium Heat

3rd step: High Heat

14. Wiper Switch

Pull up to operate the wiper. Push down to stop the wiper.

15. Car Radio

16. Fuse Box

Seven 15A fuses are used.

17. Swing Lock Pin

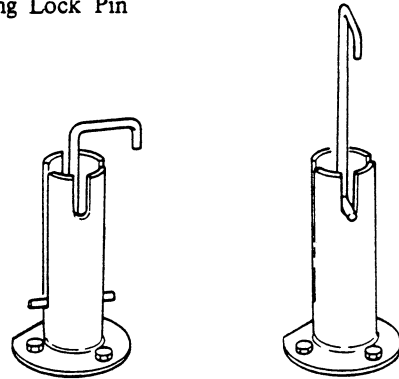

[Locked]

[Lock Disengaged]

CAUTION

Be sure to lock the upper when propelling or during transportation.

18. Ammeter

This shows the ampere produced by the generator and indicates the condition of the charging system. The range of green shows the charging condition.

19. Glow Plug Indicator

This indicates the condition of the glow plug. This plug lights when the starter switch is turned to the "HEAT" position.

20. Room Light Switch

The room light is lit.

21. Panel Light

This lights up the panel.

1.2 ADJUSTMENT OF OPERATOR'S SEAT

The operator's seat is a reclining type seat. Adjust the seat so that operation can be performed in the most comfortable position.

1. Reclining Adjustment

By pulling up the adjustment lever, the reclining angle can be adjusted forward or backward.

2. Sliding Adjustment

Pull up the lever at the front of the seat to slide the seat forward or backward.

3. Height Adjustment

Rotate the knob for height adjustment.

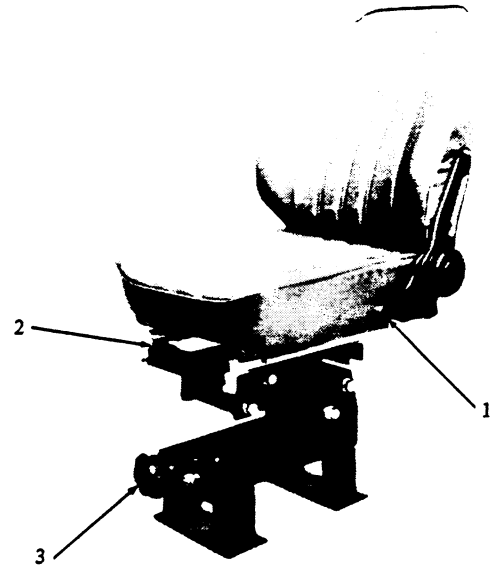

L-1683

WARNING

As an option, a seat belt can be provided. For safety purpose it is recommended to use a seat belt for heavy work, working on slopes, etc., or at sites where seat belts are necessary. Be sure to replace the seat belts every 3 years.

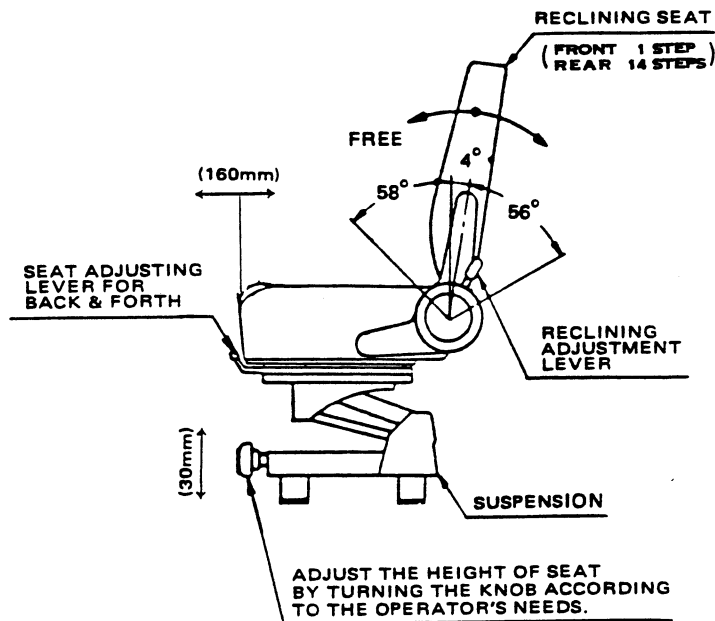

L-1762

1.3 OPERATOR'S CAB WINDOWS

● Front Window

The front window can be moved in overhead. This can be done from inside of the operator's cab as follows:

1. Place the machine on flat level ground.
2. Disconnect wiring of the wiper.
3. Remove the upper and lower locks of the front window.
4. Lift and move the front window upward until the window is seated in the ceiling.
5. After lifting the window to the ceiling, be sure to lock the front window at the rear of the cab.

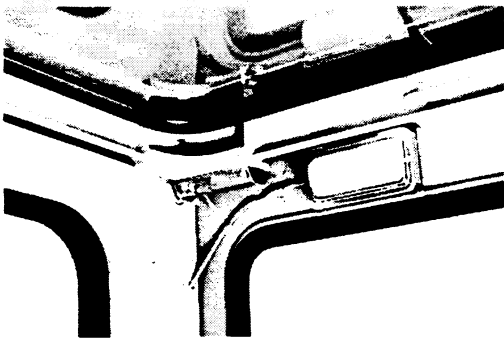

L-1684

[Locks for Upper Window in Opened Position]

WARNING

1. Do not open or close windows on a slope.
2. When closing the front window, draw the window down slowly and be careful not to place your fingers between the windows.

● Right Window

On the right side of the cab is a sliding window which can be opened and closed to the left or right.

WARNING

As the boom is being raised or lowered outside the right window during operation, do not stick your hand or elbow out.

● Left Door

The window in the door at the left can be wound up and down with the handle. When operating the machine with the left door open, be sure to engage the door lock.

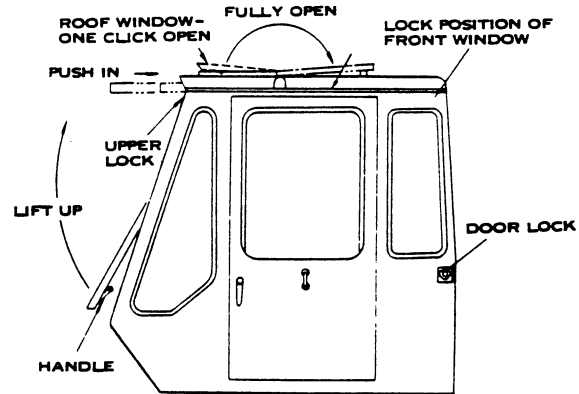

L-1763

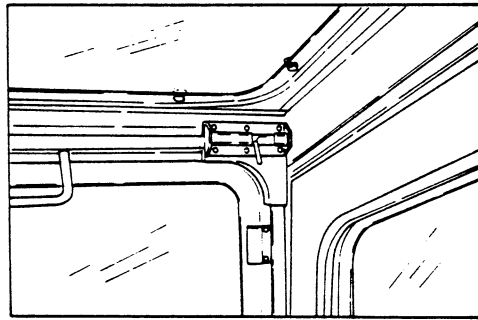

L-1243

[Upper Lock of Front Window]

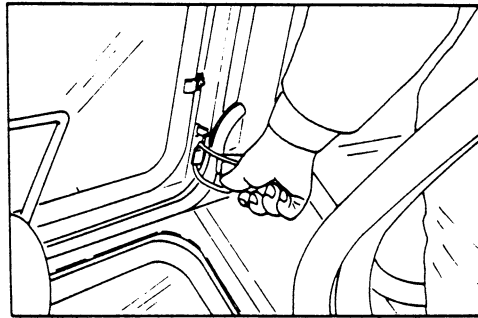

L-1244

[Lower Lock of Front Window]

● Overhead Window

When closing the overhead window, lift up and lay down slowly as this window can be fully opened.

WARNING

When closing and opening the windows, be careful not to place your fingers between windows and be sure to lock the windows.

2. PRE-OPERATION CHECKS

To prevent accidents from occurring and to increase the efficiency of the machine, the operator should carry out the recommended maintenance and lubrication checks before starting operation.

For procedures of carrying out these checks, refer to the separate shop manual "PREVENTIVE MAINTENANCE."

3. NEW MACHINE PRECAUTIONS

For the first 50 hours, do not engage the machine in heavy duty operation or run the engine at more than

1500rpm. Excessively hard work during this running-in period can result in damage to the whole machine.

4. STARTING AND STOPPING THE ENGINE

For operation of the engine, refer to the Engine Manual.

4.1 STARTING THE ENGINE

1. Make sure all control levers are in neutral before starting the engine.
2. Pull the engine throttle lever back slightly.
3. Insert the key into the engine starting switch and turn the key one click to the right and make sure the alarm lamp lights up.
4. Turn the key further to the right and the engine will start. Immediately release the key when the engine has started to run.

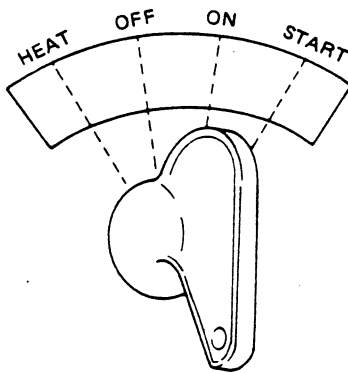

L-1247

NOTE

Do not try starting the engine for longer than 30 seconds at a time. If the engine does not start, wait for 2~3 minutes to allow the battery to recover. If the engine still does not start after trying four times, refer to the Engine Manual for troubleshooting.

5. After the engine has started and is running smoothly, reduce its speed to low idling.
6. When the weather is cold, turn the ignition switch to the left before starting the engine until the glow plug indicator glows red to perform preheating of the engine air-intake.
7. Immediately after the engine has started, make sure all gauges show the proper reading. If the readings are unusual or zero, stop the engine and determine the cause of the faulty gauge reading before continuing operation. Check also for any abnormal sounds, color of exhaust gas and for fuel or oil leaks or unusual smells.

NOTE

For cold weather starting, refer to the Engine Manual but also see "Operation in Cold Weather" later in this manual.

4.2 STOPPING THE ENGINE

1. Lower the bucket to the ground and place all control levers in neutral.
2. Allow the engine to run at half speed or less for about 5 minutes to allow the engine to cool off evenly.
3. Return the engine throttle lever to the idling position, then pull the engine stop knob to stop the engine.
4. Turn the engine starting switch OFF and remove the key. Check that all gauges read zero and the alarm light is off.

5. WARM-UP OPERATION

If the engine is heavily loaded while it is still cold, it may cause damage to the hydraulic pump and cause early wear to the engine which will not be running as efficiently as it should be.

Before starting operation, be sure to warm up the engine as follows and start work only after the temperature of the engine has risen.

1. Idle the engine for 5 minutes without load.
2. Next, increase the engine speed to about half speed and using the bucket control lever to extend or retract the bucket cylinder, warm up the hydraulic oil for about 5 minutes.

3. Increase the engine speed to its maximum speed and operate the bucket or arm control lever in relief state for about 5~10 minutes. Warm up each component equally circulating hydraulic oil to the swing and propel motors.

(Operate the levers slowly if the hydraulic oil temperature is low. Do not operate the levers suddenly.)

The proper operating temperature of the hydraulic oil is between 50°~80°C, but before starting operation be sure to raise the temperature up at least 20°C.

6. OPERATION

6.1 BACKHOE ATTACHMENT OPERATION

Extending and retracting of the cylinders – boom, arm and bucket – and swing direction are determined by the control levers. The amount they are shifted determines the speed of each actuator.

When the levers are released, all motion of the actuators will stop. Combination operations can also be done.

CAUTION

When the swing lever is in neutral, the brake valve will act to stop the swing. However, this mechanism is designed to operate gradually in order to avoid shocks to the machine and operator. Therefore, when stopping the swing motion, remember to allow for this slight inertia swing that occurs after the control lever is put in neutral.

There are several different control lever layout patterns. These layouts are shown on pages 9 and 10. When you receive your machine, check which layout you have by checking what lever operates what actuator.

6.2 FACE SHOVEL OPERATION

It should be noted that operation of the control lever of face shovel is opposite to that of backhoe attachment.

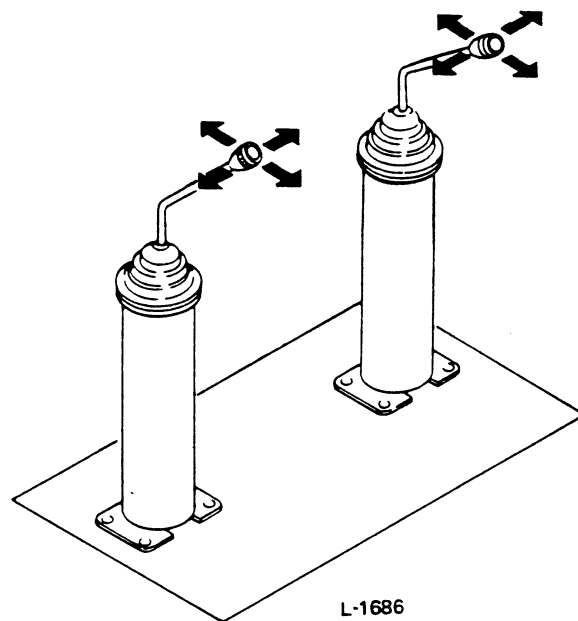

6.3 LOADING SHOVEL OPERATION

The lever operation and the function of each part are as follows.

6.4 PROPEL OPERATION

1. Forward or Reverse Propelling on Flat Ground

(with propel motors at rear)

Push both levers forward and the machine will propel forward. Pull both propel levers backward toward the operator for reverse propelling.

Speed for both forward or reverse propelling can be regulated according to the amount the levers are shifted.

2. Pivot Turn

This is done by driving only one of the crawlers and can be performed by operating either one of the propel levers.

3. Spin Turn

This is done by driving the crawlers in opposite directions. Push one propel lever forward and pull the other one backward.

4. Grades

The maximum gradeability of the machine is 58% (30°).

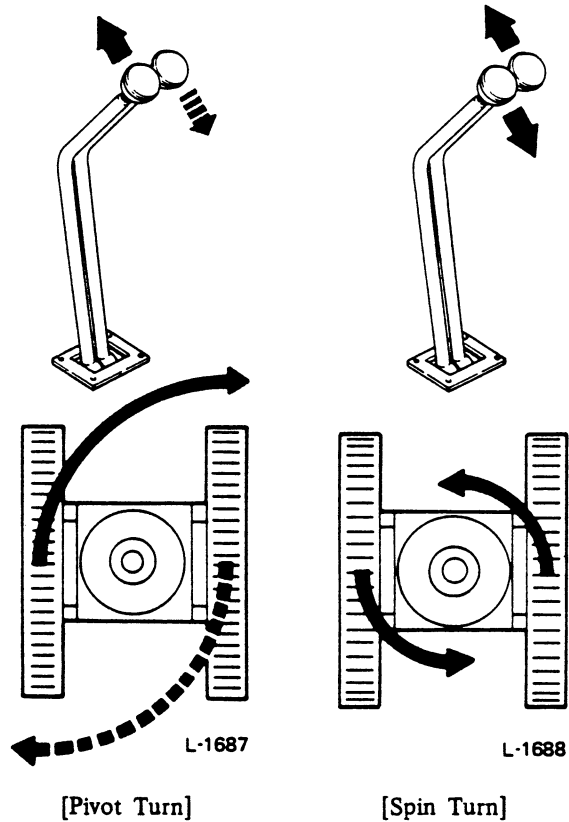

6.5 SWING LOCK

When there is no swinging necessary, such as propelling and/or transportation, secure the upper and the lower carrier with the swing lock pin. There are two locking positions – with the upper facing forward and facing backward.

When the swing lock has been engaged, make sure that it is properly engaged by looking from the outside of the cab. Before beginning the operating cycle, be sure to disengage the swing lock.

[Right Swing Left/Right Lever System]

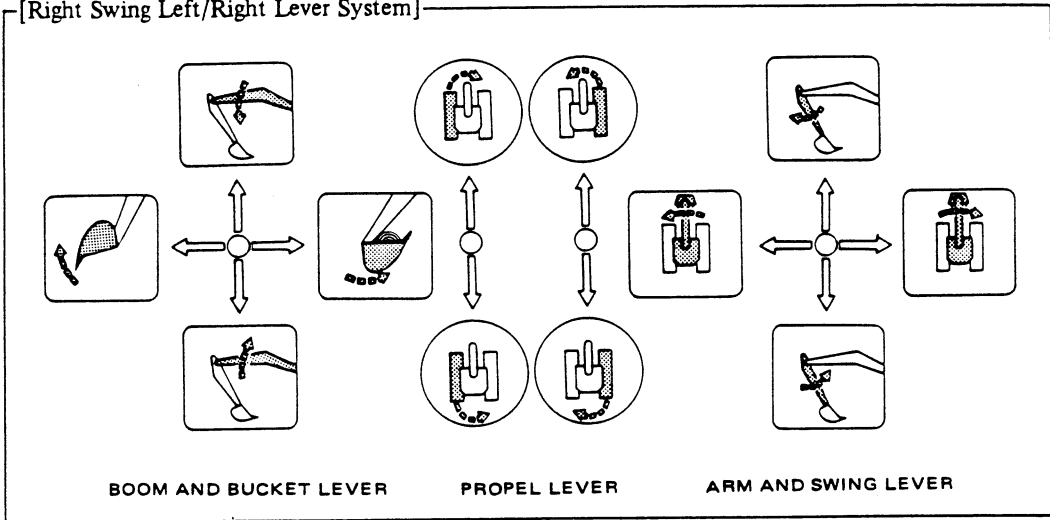

L-1556

[Left Swing Left/Right Lever System (ISO Type)]

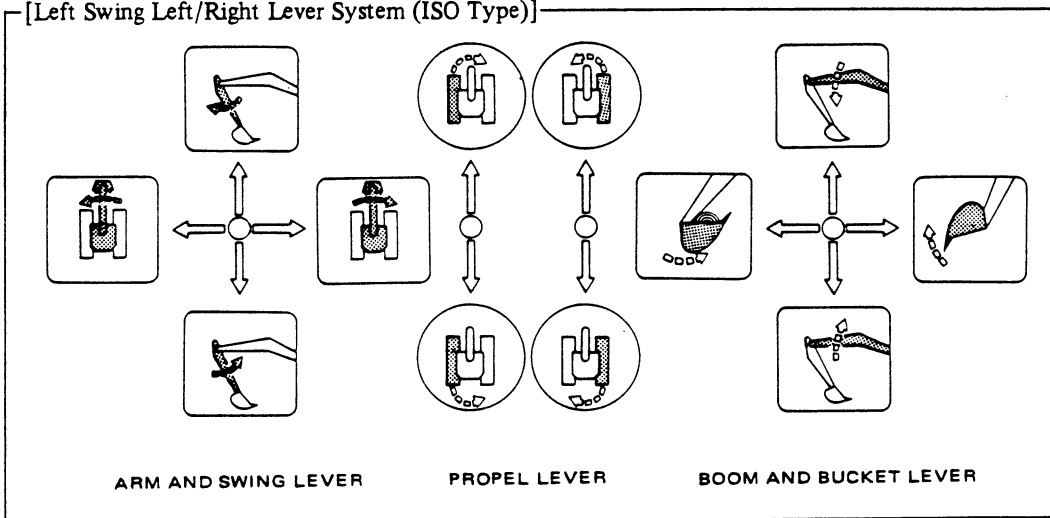

L-1689

[Left Swing Forward/Backward Lever System]

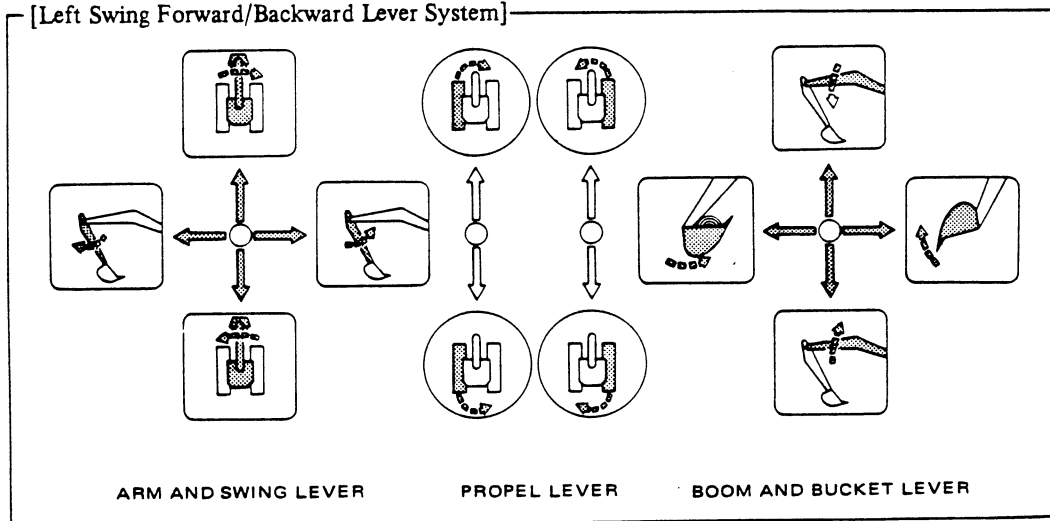

L-1557

[Loading Shovel]

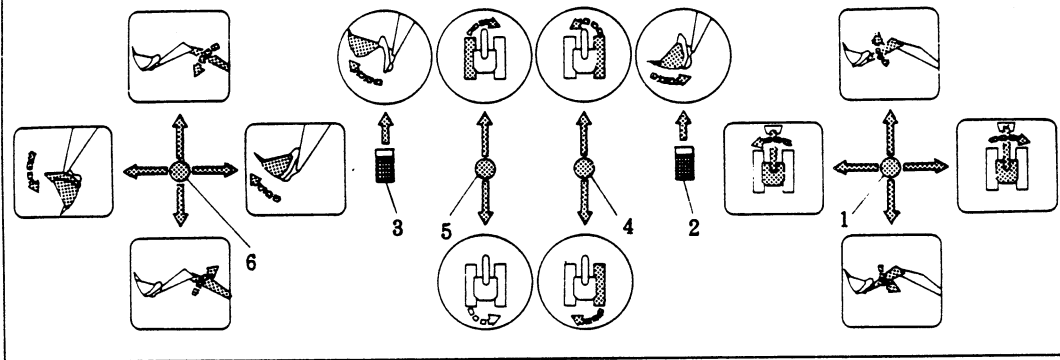

L-1629

- | | |
|---------------------------------|-------------------------------|
| 1. SWING, ARM CONTROL LEVER | 4. RIGHT PROPEL CONTROL LEVER |
| 2. BUCKET CLOSING CONTROL PEDAL | 5. LEFT PROPEL CONTROL LEVER |
| 3. BUCKET OPENING CONTROL PEDAL | 6. BUCKET, BOOM CONTROL LEVER |

7. OPERATION UNDER UNUSUAL CONDITIONS

7.1 OPERATION IN COLD WEATHER

1. In cold areas, the starting of the engine is especially difficult as the engine oil viscosity will increase and battery power is reduced. In accordance with the starting instructions referred to in the Engine Manual, start the engine in one try if possible.
2. Immediately beginning operation when the engine is still cold may cause early engine wear and damage to the hydraulic pumps and the machine will not be able to work at full power. Always go through the following hydraulic oil warm-up procedure before starting actual operation and if necessary, extend the time of warm-up to raise the oil temperature.

NOTE

Covering the entire radiator is also a method to aid warm-up. If necessary, especially in cold areas, cover part of the radiator to maintain sufficient warmth during operation.

3. In accordance with the Engine Manual, use engine oil with a suitable viscosity.
4. In low temperatures, it is necessary to use lower viscosity fuel, so select a suitable fuel from the "Lubricant, Hydraulic Oil, Fuel" chart in the separate manual.
5. Use hydraulic oil suitable to the climate in accordance with this "Lubricant, Hydraulic Oil, Fuel" chart.

CAUTION

When hydraulic oil is cold, slowly move all the control levers.

6. When there is a sudden drop in temperature in winter or in cold areas, the cooling water can freeze and result in damage to the radiator, cylinder block or the cylinder head.

In order to prevent this from occurring in winter or in cold areas, the use of a permanent type anti-freeze is recommended.

To fill anti-freeze, proceed as follows:

- 1) Open the drain cock of the radiator and crank case and drain out cooling water thoroughly.
- 2) Next, tighten each drain cock and fill water up to one-fifth of the cooling water capacity.
- 3) Using the chart, add the required amount of the specified anti-freeze and then fill water up to the top of the radiator core.
- 4) Next, run the engine until the temperature is about 80°C so that the thermostat will function.
- 5) Stop the engine and add more water not higher than 1~2cm above the radiator core. This is necessary to prevent overflow of the coolant caused by thermal expansion.

NOTE

1. The anti-freeze mixture to be filled should be of the same concentration as that originally filled.
2. Decide the concentration of the anti-freeze to be for a temperature 5°C lower than the lowest anticipated temperature of the area in which your machine is working.
3. In summer or hot weather, it is recommended that anti-freeze be removed. Open the heater cock and fully drain out any coolant remaining in the heater.
7. When using the heater in cold weather, be sure to open the heater cock.
8. Keep the battery fully charged at all times. A discharged battery will freeze before a fully charged battery.

NOTE

Keep the battery terminal connections clean and free from snow and ice which could short circuit the terminals. If there is corrosion on the cable connector and battery terminals, use a soda and water solution to remove the corrosion.

In cold weather, it is advisable to remove the battery and store it in a heated area if the machine

is to be idle overnight or for any extended period of time.

9. After completion of work, clean the crawlers and drive the machine onto wooden planks to prevent crawlers from being frozen to the ground. Extend the boom, arm and bucket out as far as possible so as to reduce the exposed part of the cylinder rods. Also, wipe off any water on the exposed part of the cylinder rods.

7.2 OPERATION IN EXTREME HEAT

1. Refer to the Engine Manual and use engine oil of suitable viscosity according to the temperature.
2. Always maintain the correct level of cooling water and check the cooling system for leaks. Change the cooling water and clean the cooling system occasionally to prevent rust and furring in the system.
3. Clean the radiator cooling fins, particularly the air passages, of insects, leaves, dirt or wooden chips that will restrict air flow or cause damage to the fins.
4. Keep the water pump fan belt properly adjusted.
5. If the engine becomes overheated, do not stop the engine and check the cooling system.
If the engine still overheats after refilling the cooling system, stop the engine and allow it to cool off. Drain the cooling system by opening the drain cocks on the radiator and engine block and flush out the system. Refill the cooling system with clean water. Do not use a salt or mineral water solution in the cooling system.
6. Make frequent checks of the battery electrolyte level and add distilled water as necessary to keep the proper level.
7. Pay attention to the water temperature gauge and oil pressure gauge readings, especially during operation and avoid working the engine unnecessarily at low speed. During a lull in operation, keep the engine running at low idle.

7.3 OPERATION AT HIGH ALTITUDES

1. The output power of the engine will decrease due to low atmospheric pressure at high altitudes. The engine output power should be taken into account when applying a working load to the machine.
2. Since the atmospheric pressure is low, the engine should be checked frequently for overheating.

7.4 OPERATION AT DUSTY, SANDY AREAS

1. A frequent check of the air cleaner dust indicator should be made and when the red signal appears in the window of the indicator, regardless of the inspection period, clean or replace the element and/or dust cap.

NOTE

As an option, a double element type air cleaner is available.

2. Make a frequent check of the radiator and keep the cooling fins clean.
3. Keep the filler cap of the fuel tank tight to prevent sand or dust from entering the fuel tank. Service fuel filters frequently to keep them free from sand and dust.
4. Keep the hydraulic oil tank cover tight to prevent sand and dust from entering the hydraulic system. Also, service hydraulic oil filters frequently.
5. Always keep the pins and bushes clean and clean all grease fitting before lubrication.

7.5 OPERATION AT HIGH HUMIDITY OR SOFT GROUND

1. Moisture and muddy water will cause deterioration and corrosion of paint, wiring and metallic parts. Keep parts dry and well lubricated when working in such areas.
2. If there is any appearance of rust or corrosion to any part of the machine, dry the part thoroughly

and paint the exposed surfaces. Apply a film of lubricant or grease on all machined surfaces which can not be painted.

3. After work, wash the machine and inspect all parts and perform lubrication as soon as possible.

If the swing bearing has been immersed in water or mud for some length of time, grease to the bearing until the old grease oozes out.

7.6 OPERATION AT SEASHORES

1. Check whether all plugs, cocks and bolts on the machine are tightened properly and prevent entry of salt water.
2. After work, clean the machine thoroughly washing off salt water and take adequate measures to prevent corrosion to the electrical components and the hydraulic cylinders.

NOTES



SHOP MANUAL **SK14·K914**

—LOCATION OF COMPONENTS— AND WEIGHT

TABLE OF CONTENTS

1. LOCATION OF COMPONENTS	
1.1 Backhoe	1
1.2 Loading Shovel	2
2. WEIGHT OF EACH COMPONENT	3
3. TRANSPORTATION WEIGHT TABLE	
3.1 Backhoe (~LR-0142)	3
3.2 Backhoe (LR-0143~)	6
3.3 Loading Shovel (~LR-0142)	10
3.4 Loading Shovel (LR-0143~)	11
4. INSTALLING COUNTERWEIGHT	12

Applicable Machines
L-60103~60216
LR-0117~

Revision	Date of Issue	Remarks
First edition	1983. 12	120R
First revision	1987. 1	R

1. LOCATION OF COMPONENTS

1.1 BACKHOE

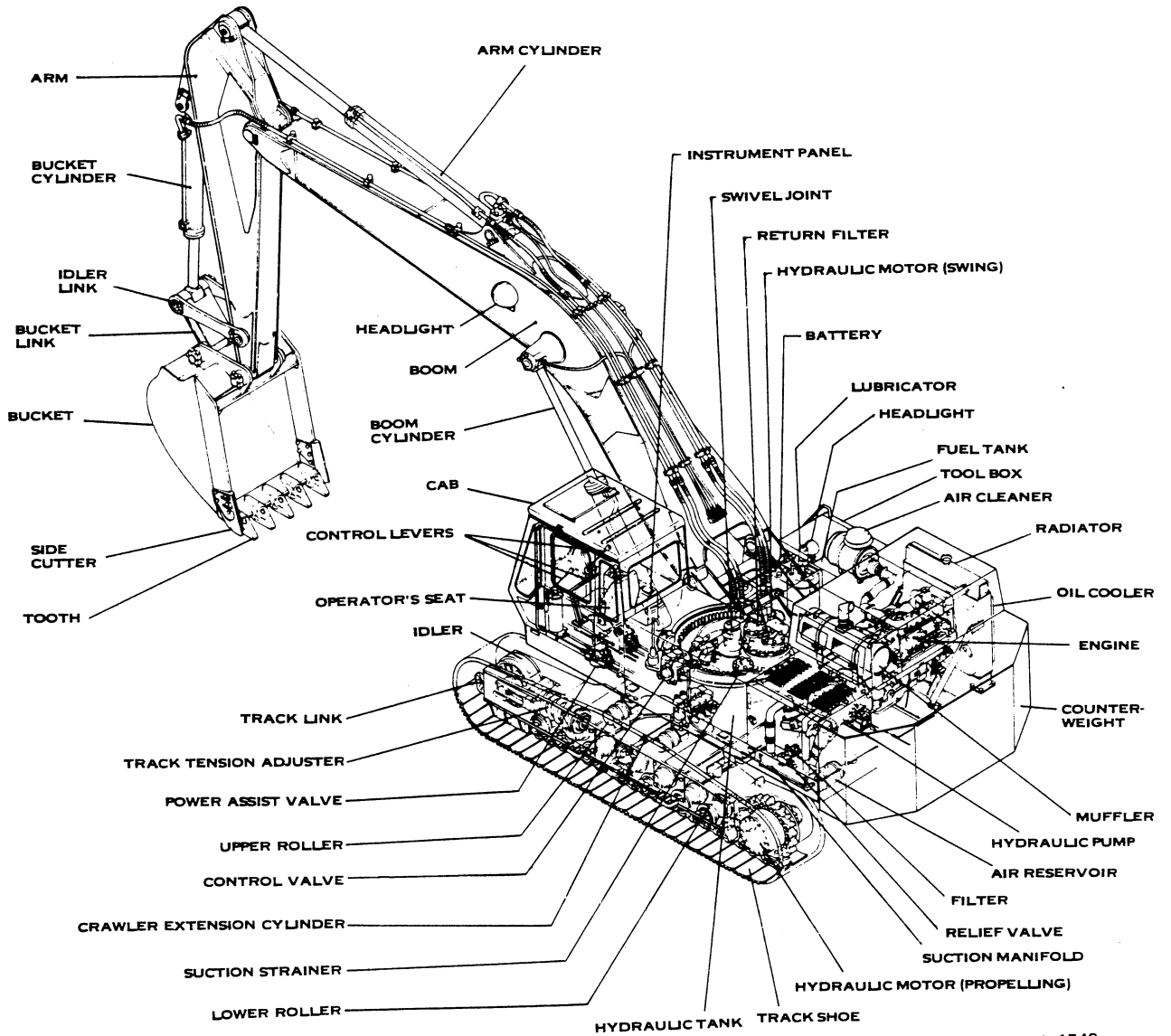

L-1749



Suggest:

For more complete manuals. Please go to the home page.

<https://www.ebooklibonline.com>

If the above button click is invalid. Please download this document first, and then click the above link to download the complete manual.

Thank you so much for reading

1.2 LOADING SHOVEL

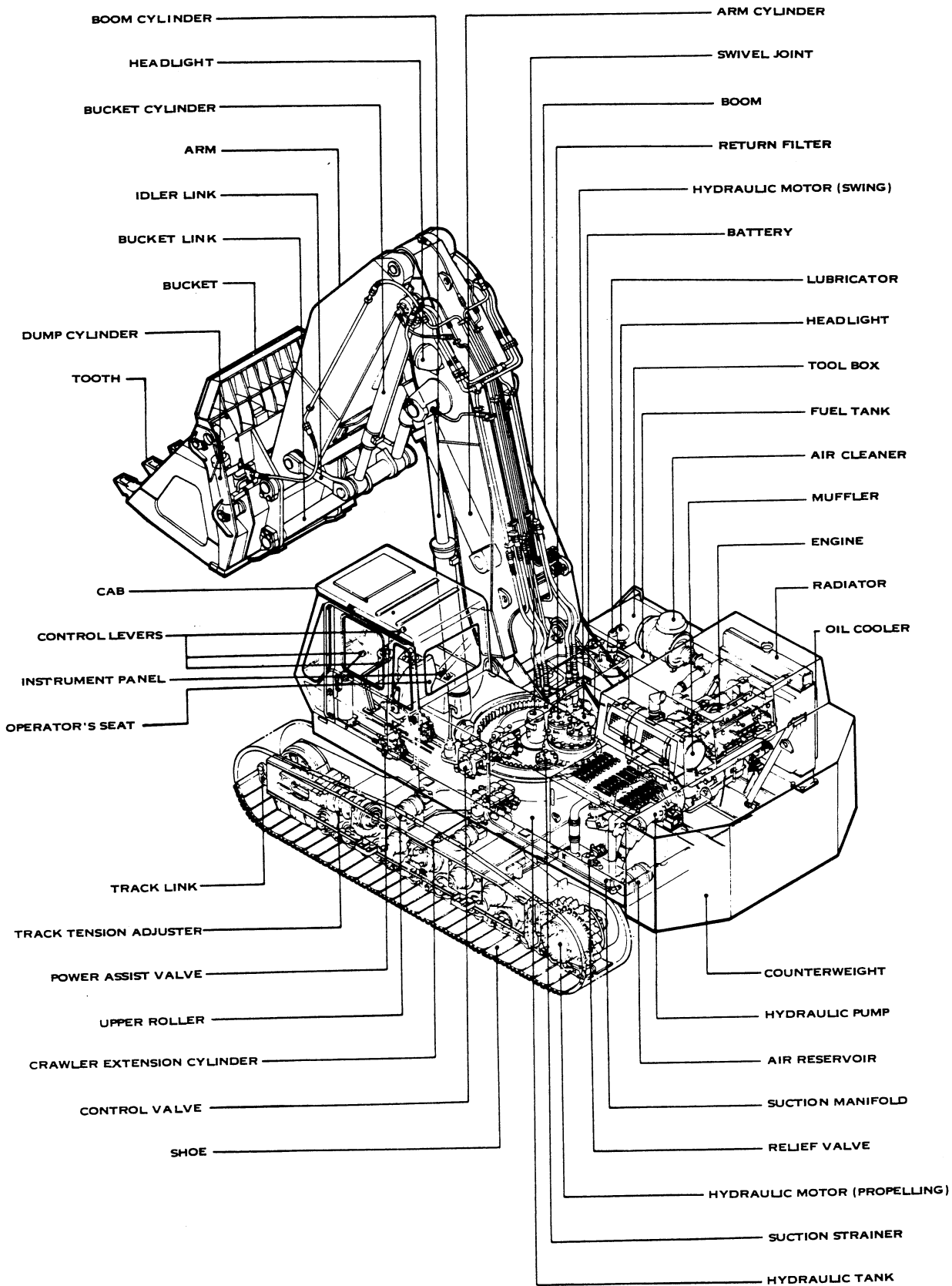

3. COUNTERWEIGHT

WEIGHT : 7.3ton

VOLUME : $1.19 \times 2.75 \times 0.75(W) = 2.5m^3$

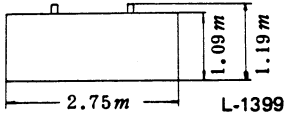

10. RIPPER BUCKET

WEIGHT : 2.0ton

VOLUME : $1.27 \times 1.96 \times 1.25(W) = 3.1m^3$

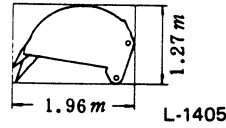

4. ARM "S" AND BUCKET

WEIGHT : 3.1ton

VOLUME : $1.24 \times 6.10 \times 1.34(W) = 10.2m^3$

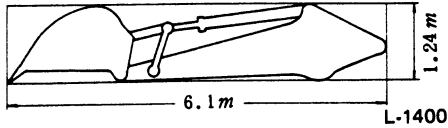

11. BASIC MACHINE OF BACKHOE

WEIGHT : 21.6ton

VOLUME : $3.05 \times 5.31 \times 3.18(W) = 51.5m^3$

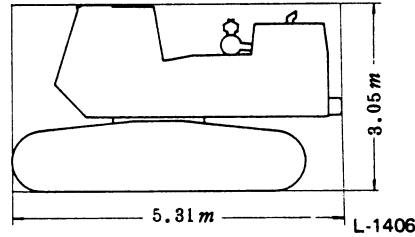

5. BOOM AND ARM CYLINDER

WEIGHT : 3.52ton

VOLUME : $1.72 \times 7.28 \times 1.22(W) = 15.3m^3$

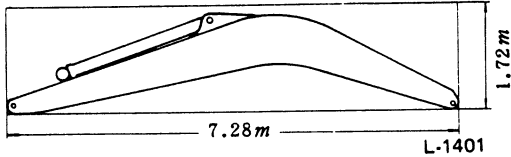

6. ARM "S" AND BUCKET CYLINDER

WEIGHT : 1.7ton

VOLUME : $1.24 \times 4.42 \times 0.72(W) = 4.0m^3$

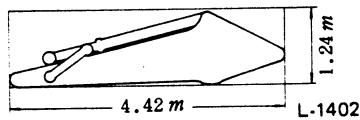

12. BOOM CYLINDER

WEIGHT : 0.68ton

VOLUME : $0.22 \times 2.24 \times 0.5(W) = 0.25m^3$

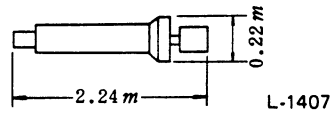

7. SHORT ARM AND BUCKET CYLINDER

WEIGHT : 1.7ton

VOLUME : $1.35 \times 3.90 \times 0.72(W) = 3.8m^3$

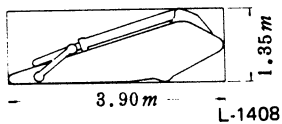

13. BUCKET (1.6m³ for Short Arm)

WEIGHT : 1.6ton

VOLUME : $1.25 \times 2.09 \times 1.40(W) = 3.7m^3$

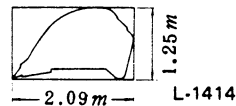

8. BUCKET (1.4m³)

WEIGHT : 1.4ton

VOLUME : $1.22 \times 2.03 \times 1.34(W) = 3.3m^3$

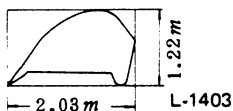

14. BUCKET (1.6m³ for "S" Arm)

WEIGHT : 1.6ton

VOLUME : $1.22 \times 2.03 \times 1.49(W) = 3.7m^3$

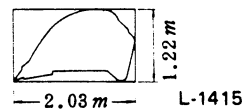

9. RIPPER

WEIGHT : 0.9ton

VOLUME : $0.98 \times 1.82 \times 0.61(W) = 1.1m^3$

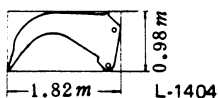

15. H.D. (Heavy Duty) BUCKET

WEIGHT : 1.5ton

VOLUME : $1.23 \times 2.08 \times 1.27(W) = 3.25m^3$

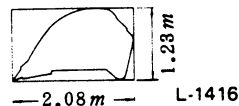

[With S (3.2m) Arm and Short (2.7m) Arm]

<https://www.ebooklibonline.com>

Hello dear friend!

Thank you very much for reading.

Enter the link into your browser.

The full manual is available for immediate download.

<https://www.ebooklibonline.com>