

KOBELCO

SHOP MANUAL
HYDRAULIC EXCAVATOR
K935

S5LU0002E-1 NA

Issued: 10-1988

APPLICABLE:
L-70106~70110, 70120~70166
LU-0067~

HYDRAULIC EXCAVATOR

SHOP MANUAL

model

K935

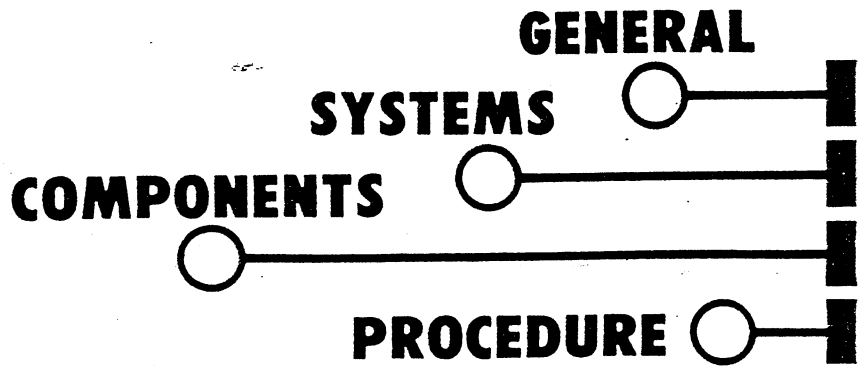

KOBELCO

Book code No. S5LU0002E①

SHOP MANUAL

model

K935

TABLE OF CONTENTS

1. SPECIFICATION	LU01
2. OPERATION AND CONTROLS (Refer to Operators Manual)	LU02
3. LOCATION AND WEIGHT OF COMPONENTS	LU03
4. MAINTENANCE STANDARDS AND TEST PROCEDURES	LU04
5. TROUBLESHOOTING	LU05
6. PREVENTIVE MAINTENANCE (Refer to Operators Manual)	LU06
7. WORKING STANDARDS	LU07

- How to Index each Shop Manual Section
The GENERAL of this shop manual consists of 7 headings as shown above. Each section can be easily referred to by indexes appended to the margin of the page as indicated on the right. Please use the indexes for speedy reference.

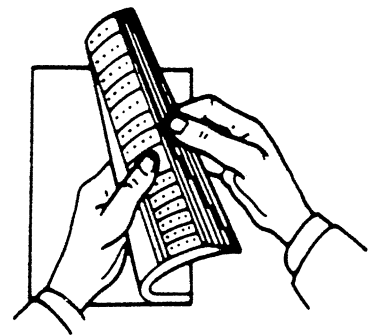

KOBELCO

GENERAL

<https://www.ebooklibonline.com>

Hello dear friend!

Thank you very much for reading.

Enter the link into your browser.

The full manual is available for immediate download.

<https://www.ebooklibonline.com>

K935 List of Shop Manual GENERAL Section

Title	Book Code No. Distribution Year-Month	
SPECIFICATION	S5LU0102 1984-10	S5LU0103E 1988-10
OPERATION	S5LU0202 1984-10	S2LU1007E Refer to Opeotors Manual
LOCATION AND WEIGHT OF COMPONENTS	S5LU0302 1984-10	S5LU0303E 1988-10
MAINTENANCE STANDARDS AND TEST PROCEDURES	S5LU0402 1984-10	←
TOOUBLESHOOTING	S5LU0502 1984-10	←
PREVENTIVE MAINTENANCE	S5LU0602 1984-10	S2LU1007E Refer to Opeotors Manual
WORKING STANDARDS	S5L00701(E)① 1984-10	←
Applicable Machines	L-70106~70166 LU-0067~0145	LU-0146~

Book code No.

S5LU0102E

KOBELCO

SHOP MANUAL **SK20-K935**

SPECIFICATION

TABLE OF CONTENTS

1. NAMES OF COMPONENTS	
1.1 Backhoe	1
1.2 Loading Shovel	2
2. MACHINE DIMENSIONS(COMPLETE MACHINE)	3
3. MAJOR SPECIFICATION	5
4. TYPE OF SHOES	5
5. TYPE OF BUCKETS	6
6. WORKING RANGE OF ATTACHMENTS	
6.1 Backhoe(with 3.25m Arm)	7
6.2 Backhoe(with 5.28m Arm).....	8
6.3 Loading Shovel	9
7. SPECIFICATIONS OF ENGINE.....	10

 **KOBE STEEL, LTD.**

Applicable Machines

L-70106~70110, 70120~70166

LU-0067~

Revision	Date of Issue	Remarks
First edition	December, 1984	100F

1. NAMES OF COMPONENTS

1.1 BACKHOE

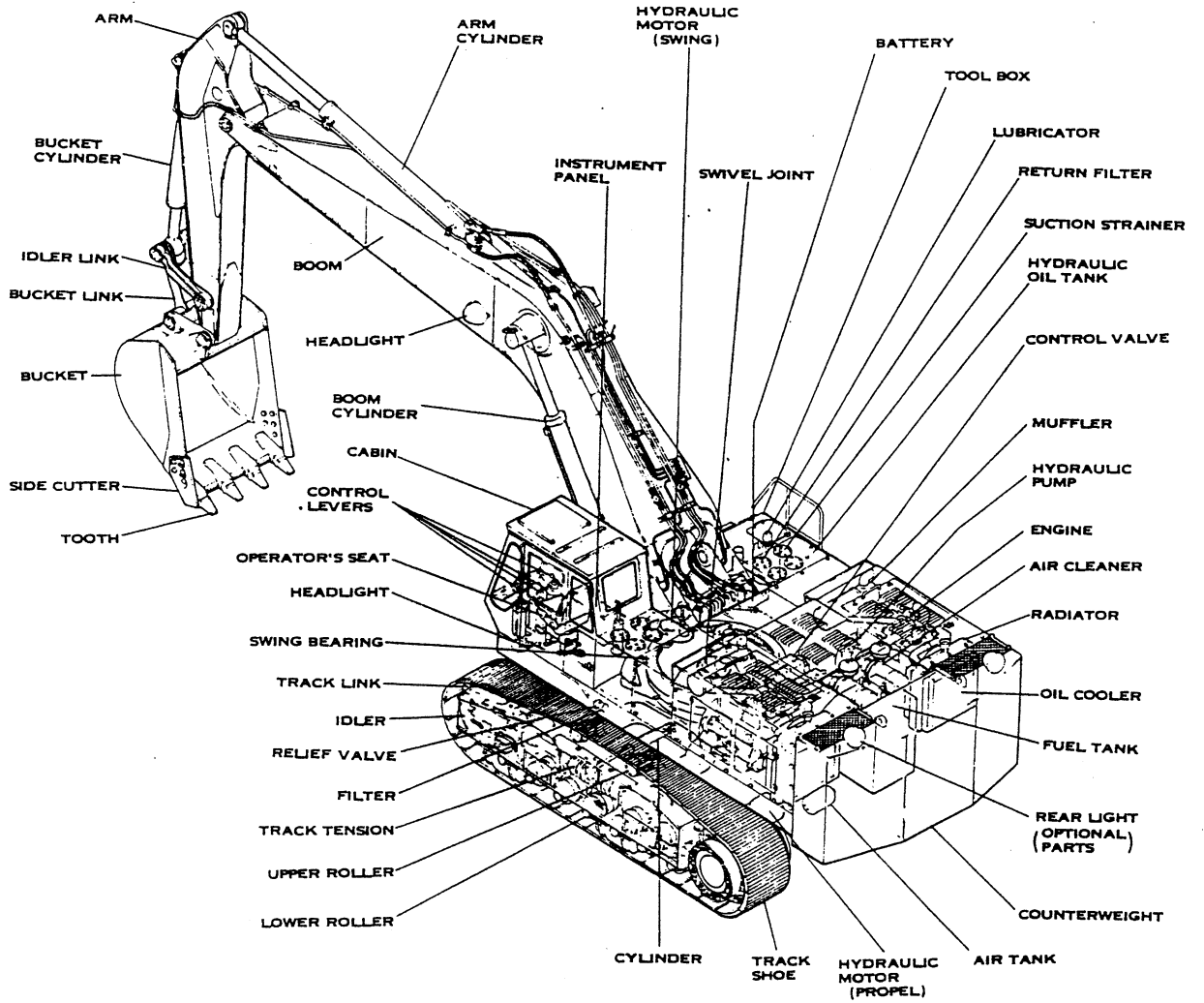

1.2 LOADING SHOVEL

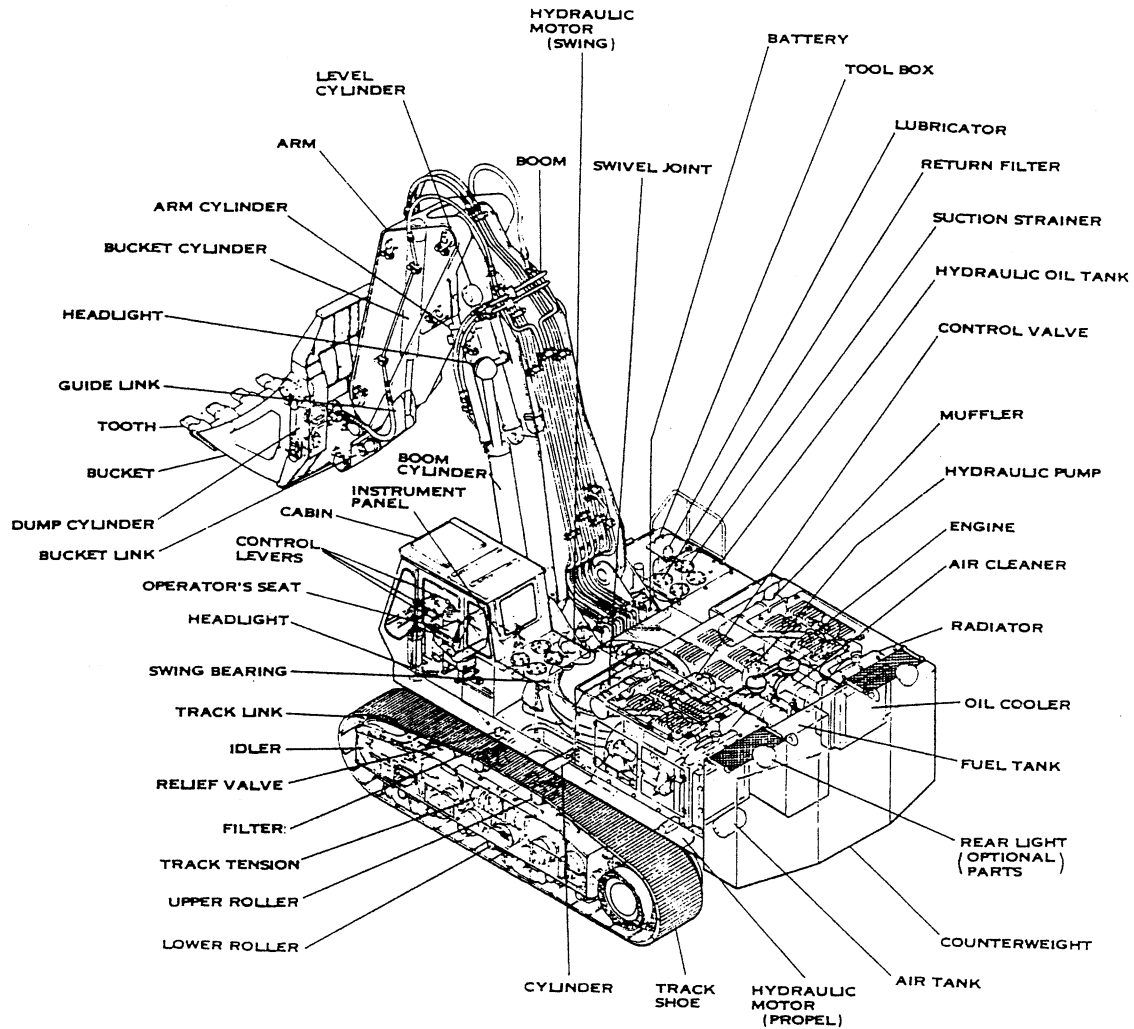

2. MACHINE DIMENTIONS (COMPLETE MACHINE)

2.1 BACKHOE(with 3.25m Arm)

2.1~2.3 — L-70106~70110, 70120~70166
 LU-0067~0085, 0087~0095

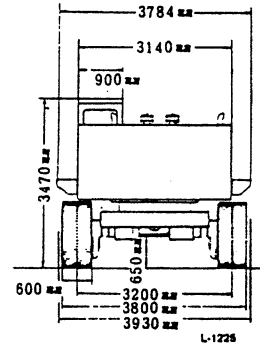
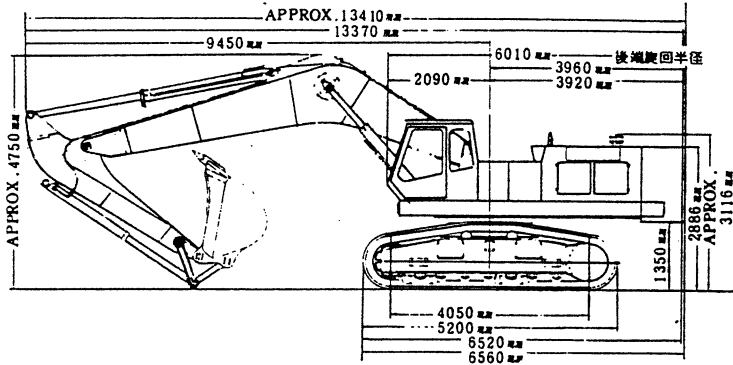

2.2 BACKHOE (with 5.28m Arm)

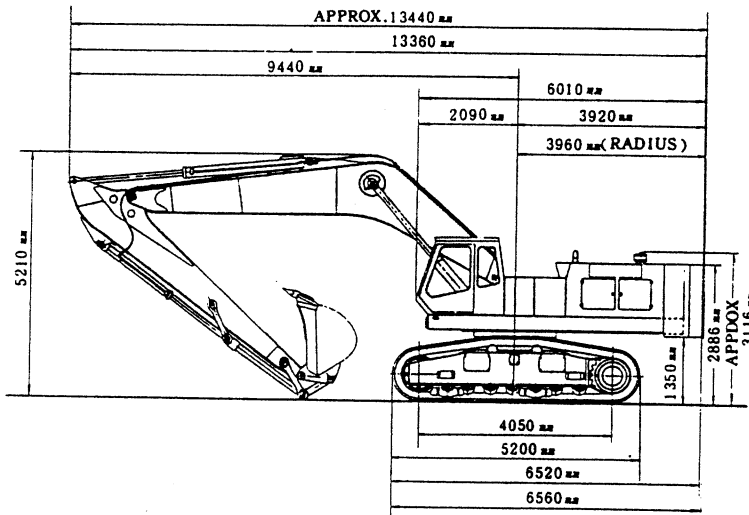

2.3 LOADING SHOVEL

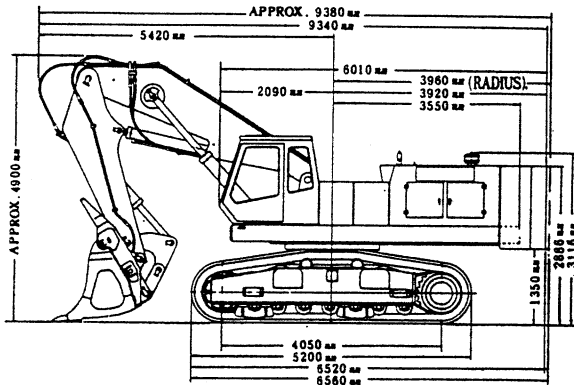

2.4 BACKHOE (with 3.25m Arm)

2.4~2.6 LU-0086, 0096~

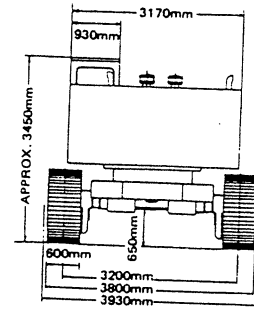
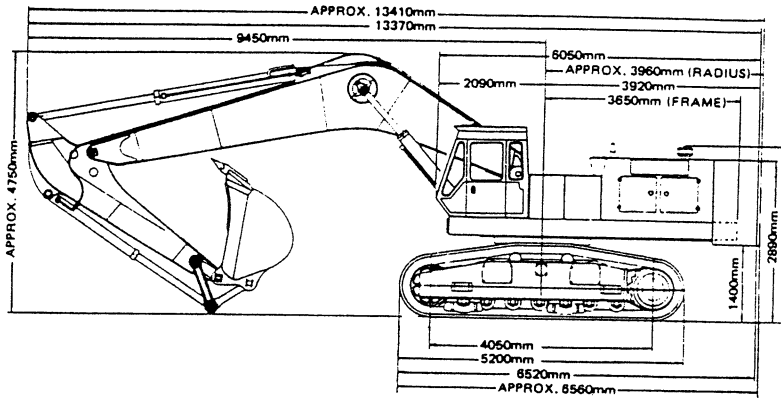

L-1907

L-1906

2.5 BACKHOE (with 5.28m Arm)

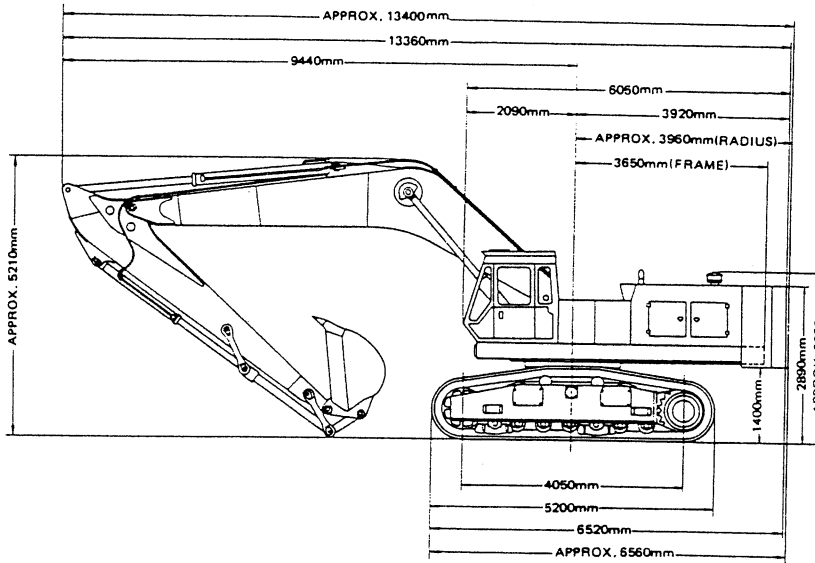

2.6 LOADING SHOVEL

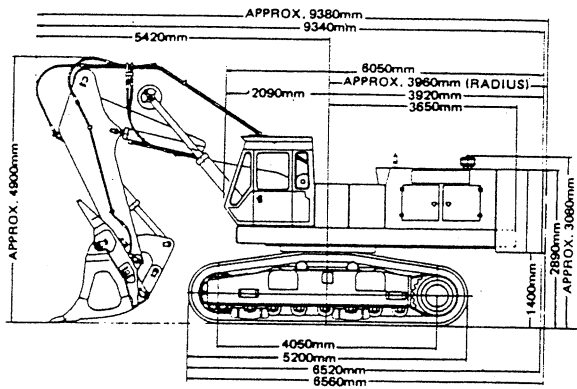

3. MAJOR SPECIFICATION

SPEED AND GRADEABILITY

	Backhoe	Loading Shovel
Swing Speed	6.3rpm	←
Propel Speed	High 3.5km/hr, Low 2.1km/hr	←
Gradeability	64% (32°)	←

WORKING WEIGHT AND GROUND PRESSURE

Working Weight	58,800kg	59,300kg	60,000kg
Ground Pressure	1.10kg/cm ²	0.95kg/cm ²	1.12kg/cm ²
Width of Shoe	600mm	700mm	600mm

HYDRAULIC COMPONENTS

Hydraulic Pump	Four Variable displacement Axial Piston Pumps, and Two Fixed Displacement Axial Piston Pumps
Motor (Swing)	Two Radial Piston Motors
Motor (Propel)	Two Axial Piston Motors
Control Valve	Hydraulic Remote Control Spool Type, Five + Four + (Two + Two) X 2 Section Multiple Control Valve
Cylinder (Boom, Arm, Bucket)	Double Acting Type Cylinders
Return Filter	Filter Paper with Safety Valve
Oil Cooler	Air-cooled Type

4. TYPE OF SHOES

TYPE OF SHOES

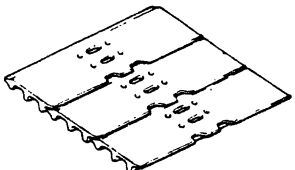
Shape	Width of Track Shoe (mm)	Overall Width of Crawler (mm)	
		Working	Transporting
 L-1516	600	3,800	3,200
	700	3,900	3,300
	910	4,110	3,510

5. TYPE OF BUCKETS

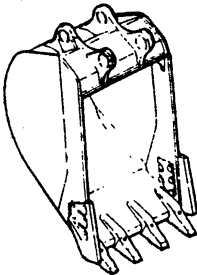
Hoe Bucket 	Heaped Capacity (m ³)	Use	Outer Width (mm)		Number of Tooth	Weight (kg)
			With Side Cutter	Without Side Cutter		
	2.3	For General Purpose	1,550	1,450	4	2,200
	2.0	For General Purpose	1,400	1,300	4	2,080
	2.0	For Rock	—	1,310	4	2,140
	1.4	For Long Arm	—	1,270	4	1,470

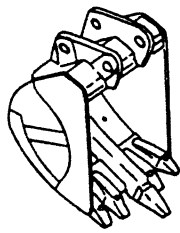
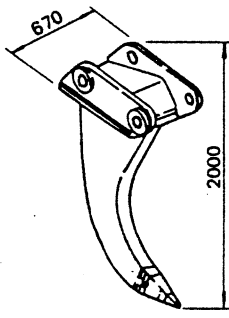
<p>Ripper Bucket</p>  <p style="text-align: center;">LF-00443</p> <p>Capacity : 1.3m³ Outer Width : 1,240mm Side Cutter : None Number of Tooth: 1 + 4 Weight : 2,800kg</p>	<p>Ripper</p>  <p style="text-align: center;">LF-00446</p> <p>Weight : 1,400kg</p>
---	--

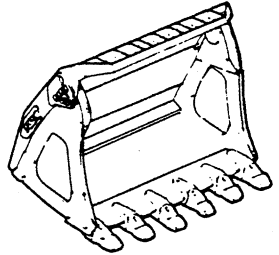
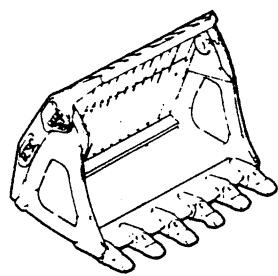
<p>Loading Shovel Bucket (For General Purpose, Bottom Dump)</p>  <p style="text-align: center;">LF-00444</p> <p>Capacity : 3.5m³ Outer Width : 2,190mm Number of Tooth: 6 Weight : 3,400kg</p>	<p>Loading Shovel Bucket (For Rock, Bottom Dump)</p>  <p>Capacity : 3.5m³ Outer Width : 2,190mm Number of Tooth: 6 Weight : 3,600kg</p>
--	--

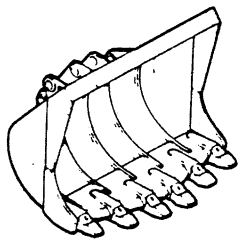
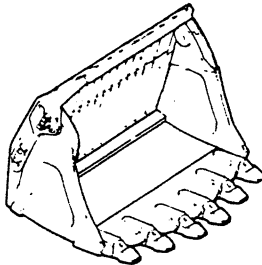
<p>Loading Shovel Bucket (For Rock, Tilt Dump)</p>  <p style="text-align: center;">LF-00445</p> <p>Capacity : 3.2m³ Outer Width : 2,430mm Number of Tooth: 6 Weight : 4,200kg</p>	<p>Loading Shovel Bucket (For Rock, Bottom Dump)</p>  <p>Capacity : 2.7m³ Outer Width : 2,140mm Number of Tooth: 6 Weight : 4,400kg</p>
---	--

6. WORKING RANGE OF ATTACHMENTS

6.1 BACKHOE (with 3.25m Arm)

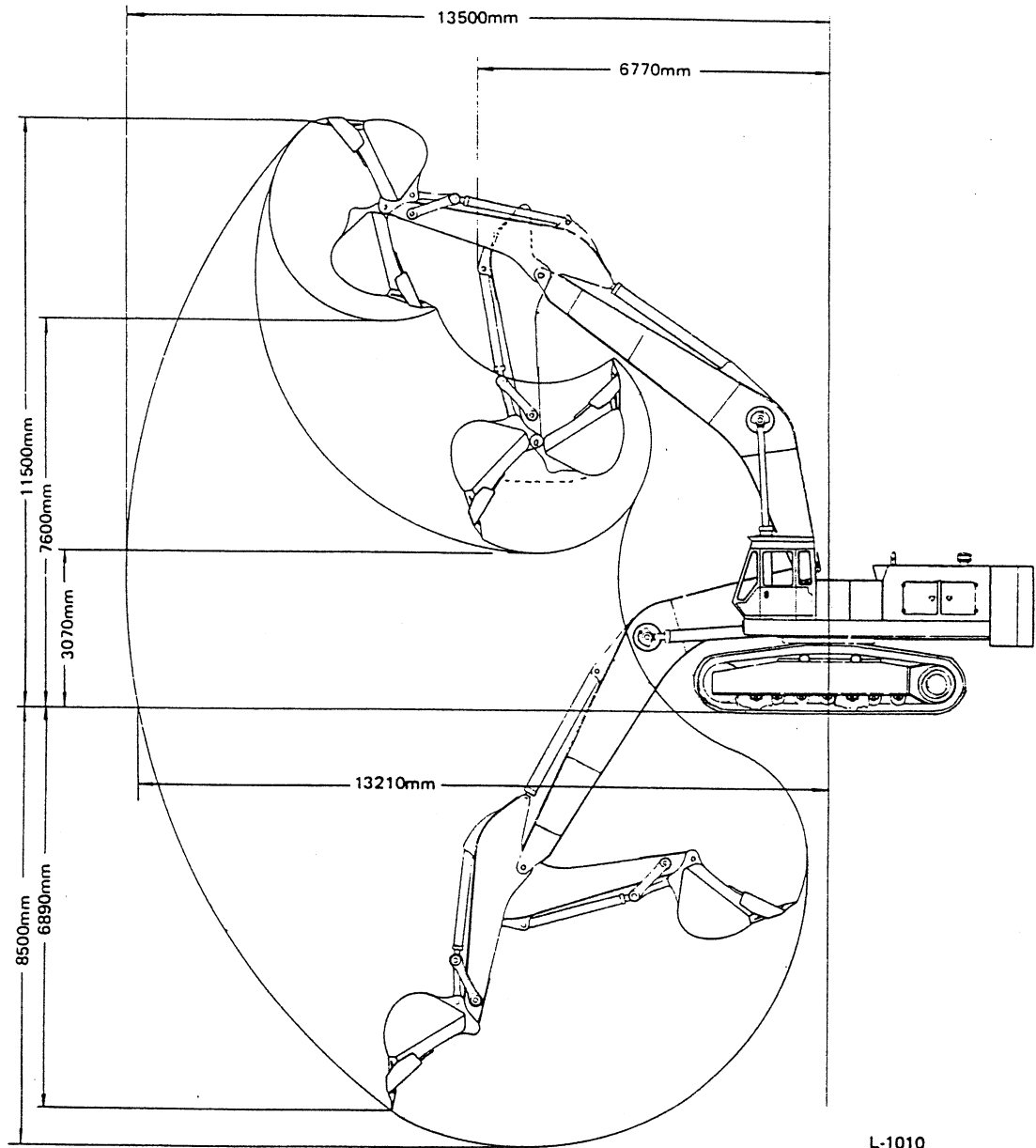

L-1010

6.2 BACKHOE (with 5.28m Arm)

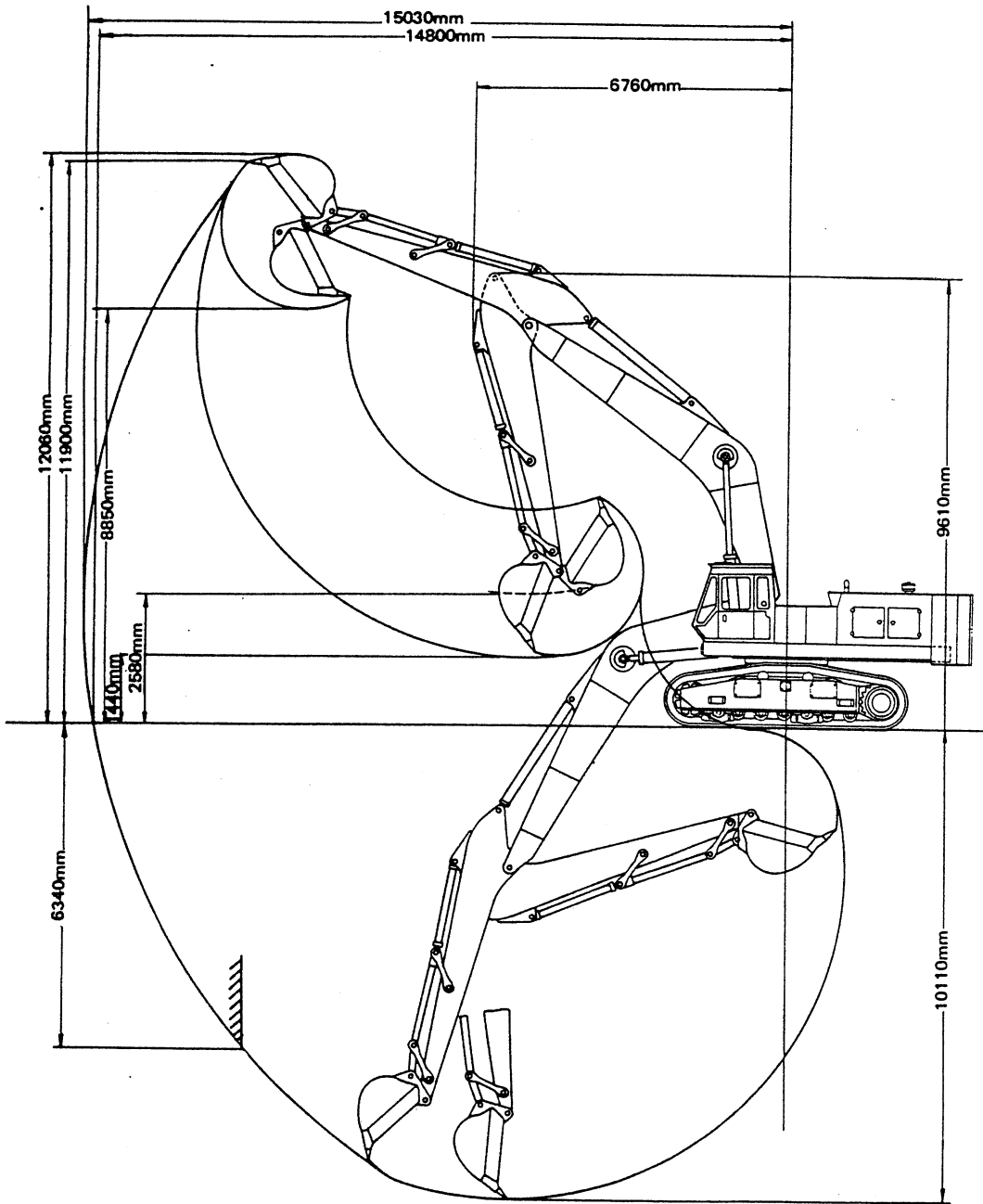

L-1933



Suggest:

For more complete manuals. Please go to the home page.

<https://www.ebooklibonline.com>

If the above button click is invalid. Please download this document first, and then click the above link to download the complete manual.

Thank you so much for reading

6.3 LOADING SHOVEL (Bottom Dump)

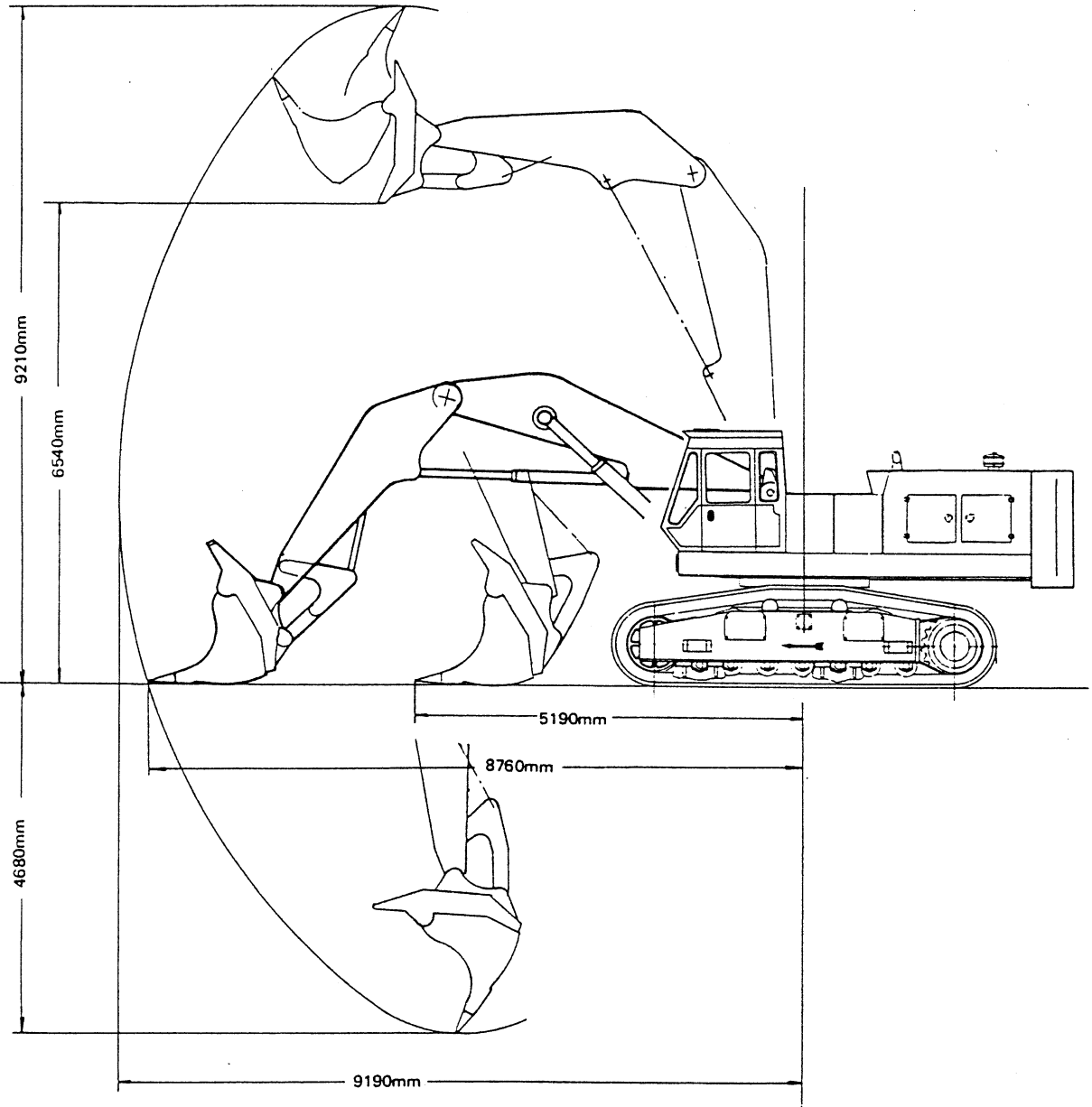

L-1009

7. SPECIFICATIONS OF ENGINE

7.1 MITSUBISHI 6D20C

Model	Mitsubishi 6D20C			
Type	4 cycle, water cooled straight overhead valve, direct injection diesel engine			
Number of Cylinders Bore x Stroke (mm)	6 - 125 x 140			
Total Displacement (cc)	10,308			
Compression Ratio (kg/cm ²)	1 : 16.0			
Rated Output (ps/rpm)	155/1800			
Max. Torque (kgm/rpm)	63/1400			
Max. Revolution without load (High Idle) (rpm)	1872 ~ 1980			
Min. Revolution without load (Low Idle) (rpm)	450 ~ 500			
Injection Order	1-5-3-6-2-4			
Injection Timing	BTDC 16°			
Injection Starting Pressure (kg/cm ²)	220			
Compressed Pressure (kg/cm ²)	28 (at 200 rpm)			
Valve Clearance Open & Closed		Valve Clearance	Open	Closed
	Suction valve	Cold 0.4mm	BTDC 18°	BBDC 50°
	Exhaust valve	Cold 0.4mm	BBDC 50°	BTDC 18°
Thermostat Operation	Start 76.5°C Full Open 95°C			
Starting Motor	24V - 6.0KW			
Charging Generator	24V - 700KW			
Dimension (mm) Overall Length x Width x Height	1566.2 x 912.3 x 1565.6 (mm)			
Dry Weight (kg)	980			

<https://www.ebooklibonline.com>

Hello dear friend!

Thank you very much for reading.

Enter the link into your browser.

The full manual is available for immediate download.

<https://www.ebooklibonline.com>