



# TABLE OF CONTENT

Introduction - Specifications ..... 1

Cutting table ..... 2

Reel ..... 3

Main crop elevator ..... 4

Threshing unit ..... 5

Rotor unit ..... 6

Shaker shoe/fanning mill ..... 7

Elevators - augers ..... 8

Engine ..... 9

Grain tank ..... 10

Engine area equipment ..... 11

Drive trains ..... 12

Wheels and tires ..... 13

Electrical system ..... 14

Hydraulics system ..... 15

Straw chopper ..... 16

General assembly instructions ..... 17

Miscellaneous data ..... 18

# 1 Introduction - Specifications

<b>1.1</b>	<b>Using the manual</b> .....	<b>1-3</b>
1.1.1	Information .....	1-3
<b>1.2</b>	<b>Dimensions</b> .....	<b>1-4</b>
1.2.1	Combine dimensions .....	1-4
<b>1.3</b>	<b>Technical specifications</b> .....	<b>1-7</b>
1.3.1	Feeding unit .....	1-7
1.3.2	Threshing sys. ....	1-8
1.3.3	Cleaning unit .....	1-10
1.3.4	Grain tank .....	1-11
1.3.5	Hydraulic system .....	1-12
1.3.6	Hydrostatic system .....	1-13
1.3.7	Engine .....	1-14
1.3.8	Electrical components .....	1-15
1.3.9	Gear oil .....	1-15
1.3.10	Transmission .....	1-16
1.3.11	Rear axle .....	1-16
1.3.12	Weight .....	1-17
<b>1.4</b>	<b>Wheels and tires</b> .....	<b>1-18</b>
1.4.1	Wheel tightening torque .....	1-18
1.4.2	Tire capacity .....	1-18
1.4.3	Tire equipment .....	1-19
<b>1.5</b>	<b>Safety Precautions</b> .....	<b>1-21</b>
1.5.1	In general .....	1-21
1.5.2	Safety in the workshop .....	1-21
1.5.3	Safety - a word to the mechanic .....	1-21
1.5.4	Warnings .....	1-21
1.5.5	Safety decals .....	1-22
1.5.6	General .....	1-22
1.5.7	Personal safety .....	1-23
1.5.8	Considerations with regard to equipment .....	1-23
1.5.9	General considerations .....	1-25
1.5.10	Operational considerations .....	1-25
1.5.11	Maintenance techniques .....	1-26
<b>1.6</b>	<b>Practical advice</b> .....	<b>1-28</b>
1.6.1	Description .....	1-28
<b>1.7</b>	<b>Start-up instructions</b> .....	<b>1-32</b>
1.7.1	In general .....	1-32
1.7.2	Pre-delivery checks .....	1-32
1.7.3	Instruction of combine operator .....	1-34
<b>1.8</b>	<b>Conversion tables</b> .....	<b>1-37</b>
1.8.1	Conventional units of measurement .....	1-37
<b>1.9</b>	<b>Locking and sealing agents</b> .....	<b>1-39</b>
1.9.1	Description .....	1-39
<b>1.10</b>	<b>Wheel</b> .....	<b>1-40</b>
1.10.1	Wheel nut torques .....	1-40
1.10.2	Bolts with metric threads .....	1-40
1.10.3	Nuts with metric threads .....	1-41

**<https://www.ebooklibonline.com>**

Hello dear friend!

Thank you very much for reading.

Enter the link into your browser.

The full manual is available for immediate download.

**<https://www.ebooklibonline.com>**



## **1.1 Using the manual**

---

### **1.1.1 Information**

---

#### **General**

All operations described in this manual relating to repairs and maintenance must only be carried out by trained service personnel. The purpose of the manual is to help dealers and workshops start up, service and repair AGCO's equipment as efficiently and effectively as possible. If the specified procedures are followed and the recommended special tools used where necessary, jobs can be completed within the time indicated in the "Repair Time Schedule" manual.

#### **Pagination**

This manual is divided into sections and chapters. The figures show:

First figure = Section

Second figure = Chapter

Third figure = Sequential number of the various components of the chapter

The publication number and version appear at the bottom of the page.

#### **Use**

To make it easier to look things up, there is a table of contents at the beginning of every chapter listing the various sections in the chapter.

#### **Modifications**

Modified pages have the same section numbering as their predecessors: Only the page number and version number change.

The old pages must be destroyed.

#### **Service tools**

In the case of jobs that require service tools, the number of the tool is specified at the point in the text where it is needed.

#### **Repairs and replacing parts**

When replacing parts, it is very important to only ever use genuine AGCO spares.

Please pay particular attention to the following points when it comes to repairs and fitting spare parts or other equipment.

Fitting non-genuine spare parts may impair the safety of the machine.

In some countries it is against the law to fit parts that do not conform to the manufacturer's specifications. Torque wrenches must always be adjusted in accordance with the instructions given in the workshop manual. Fit locking devices where specified. If the locking device breaks when removed, fit a new one.

If non-genuine AGCO parts are fitted, the machine will no longer be covered by the right to complain, as the manufacturer provides a warranty on all AGCO components. AGCO dealers are under the obligation to supply genuine parts only.

#### **Repair Time Schedule**

The "Repair Time Schedule" manual contains a table of standard time requirements for the commonest repairs on a combine. The manual's sections follow the layout of the spare parts catalog.

## 1.2 Dimensions

### 1.2.1 Combine dimensions

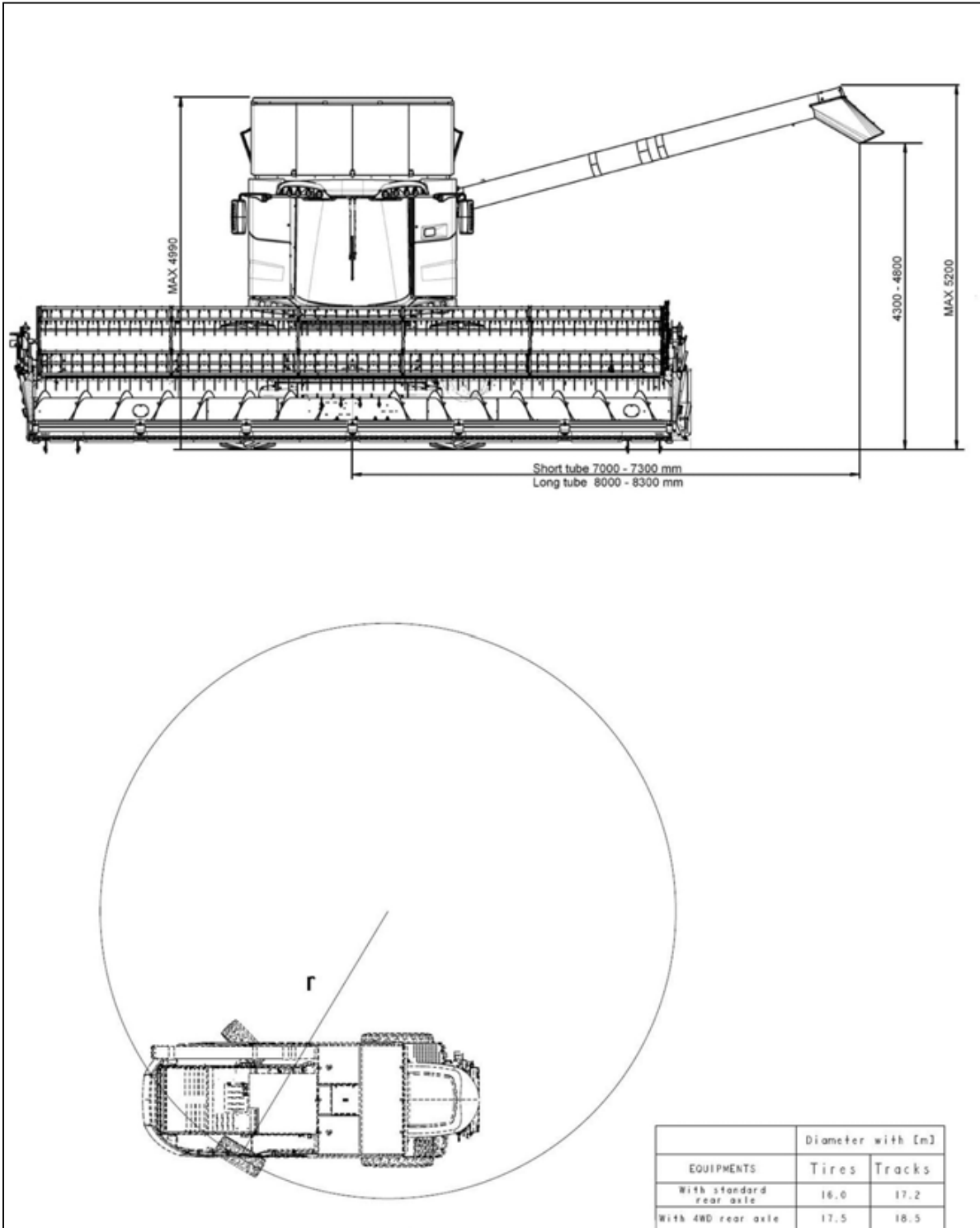

Fig. 1 Dimensions with cutting table and active unloading tube; dimensions of turning radius

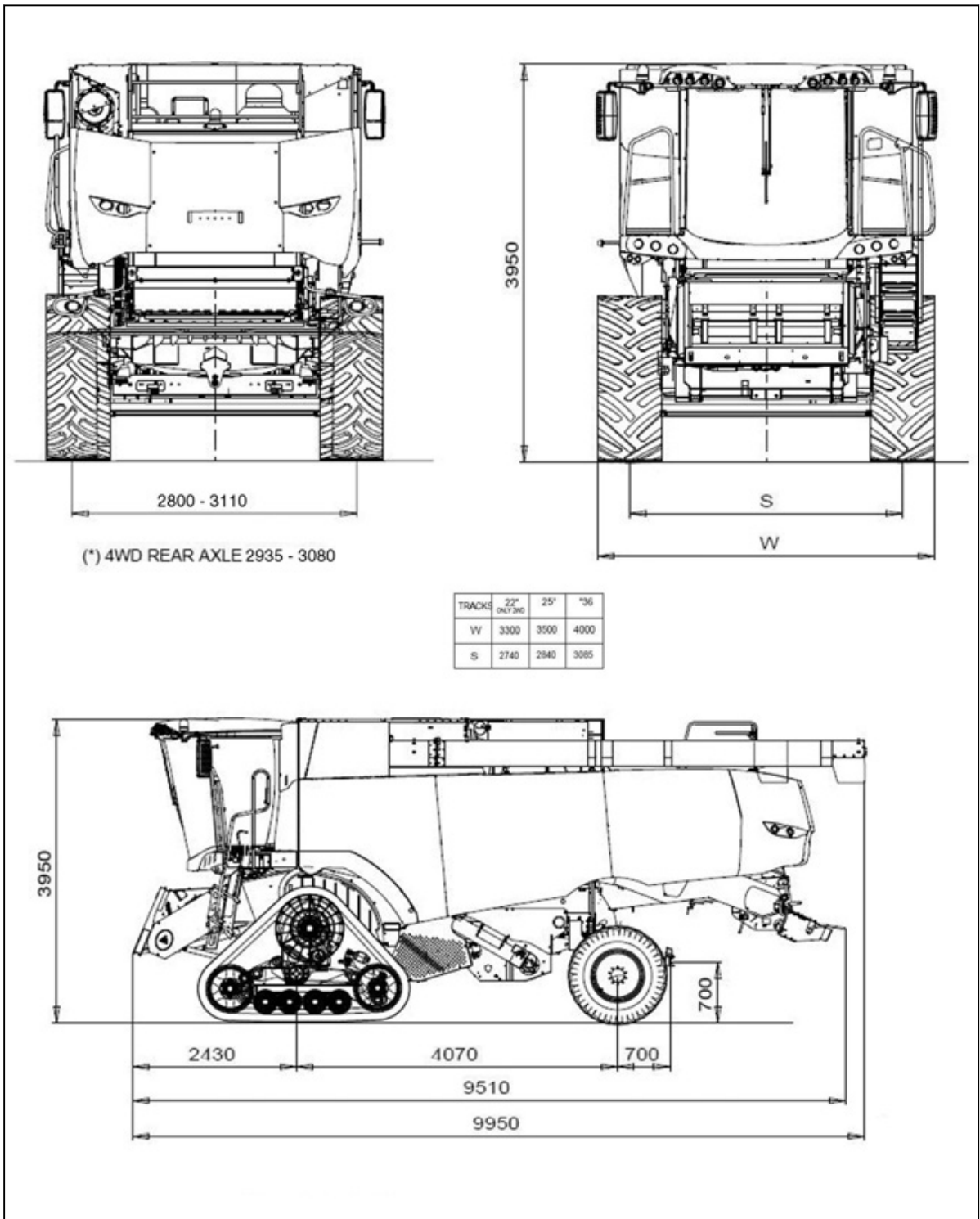

Fig. 2 Dimensions for tracked machines; front, rear, side

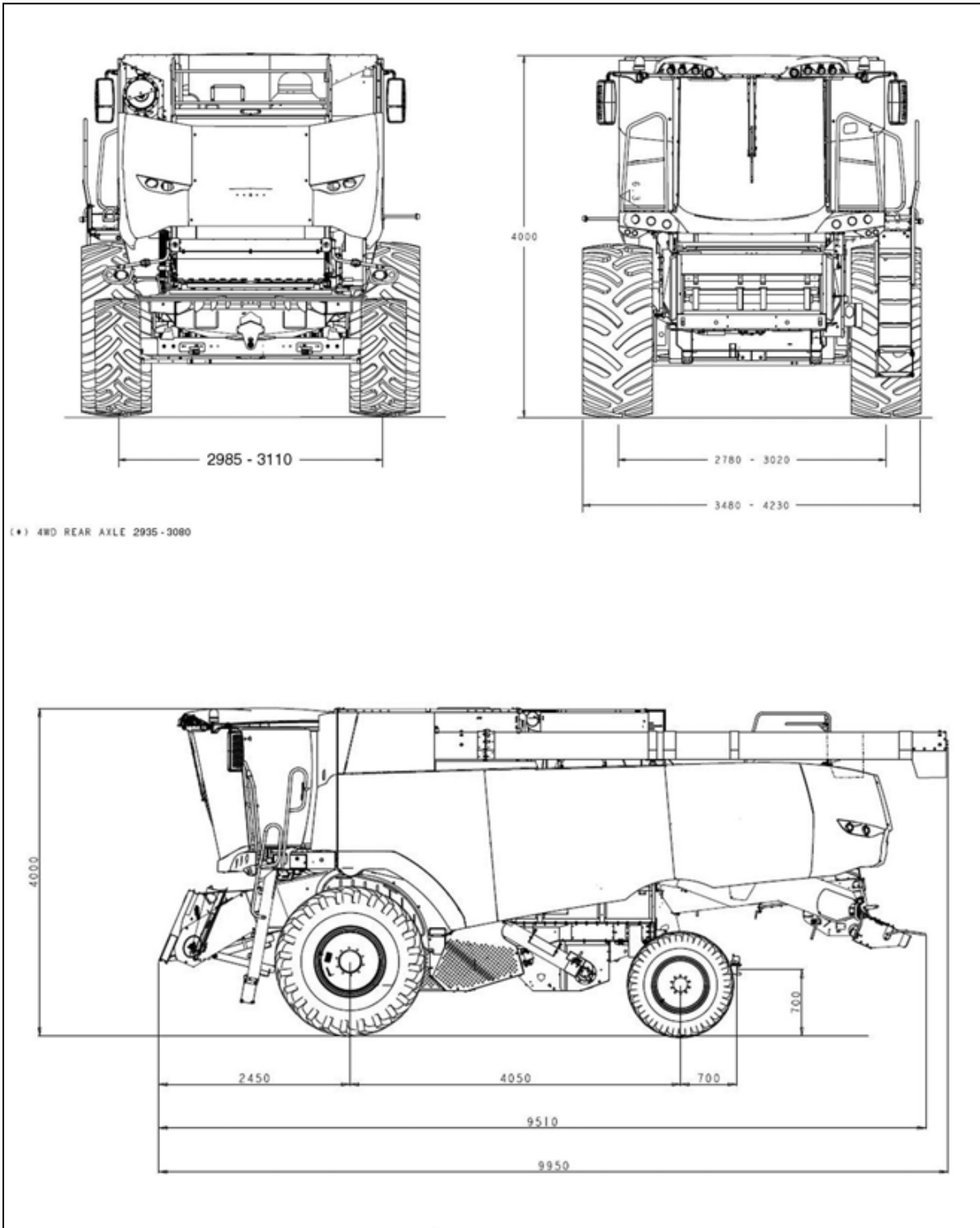

Fig. 3 Dimensions for machines with tires; front, rear, side

## 1.3 Technical specifications

### 1.3.1 Feeding unit

Feeding unit	Units of measurement	FENDT 9490 X FENDT 9490 X AL
<b>Cutting table</b>		PowerFlow
<b>Elevator</b>		universal type
Elevator chain front shaft		Spring-loaded
Chains with slats	no.	4
Slats	no.	21
Protection		Spring-loaded safety clutch
Upper shaft speed	rpm	500
Front shaft speed	rpm	620
Elevator drive belt		Powerband belt

### 1.3.2 Threshing sys.

Threshing sys.	Units of measurement	FENDT 9490 X FENDT 9490 X AL
<b>Stone trap</b>		on the concave inlet
<b>Threshing drum</b>		
Type: Cereal/maize		8 cylinder rasp bars
Cylinder housing width	mm	1680
Cylinder width	mm	1660
Diameter	mm	600
Variator		With one drive belt
Variator control		electrohydraulic
Speed	rpm	370 ÷ 1080
<b>Concave</b>		
Control		Adjustable from operator seat
Area	m <sup>2</sup>	1.06
<b>Grain type:</b>		
Clearance (between wire centers)	mm	15
Wire arrangement	mm	Alternating 350 and 700
Wrap angle		117°
Wire diameter	mm	3.5
Total number of wires	no.	110
Bars	no.	12
<b>Maize type:</b>		
Clearance (between wire centers)	mm	25
Wrap angle		117°
Wire diameter	mm	6
Bars	no.	12
<b>Rotor Feeder</b>		
Speed, normal	rpm	950
Speed, low gear	rpm	515
Diameter	mm	500
Width	mm	1680

Threshing sys.	Units of measurement	FENDT 9490 X FENDT 9490 X AL
<b>Rotor</b>		
Quantity	no.	2
Diameter	mm	475
Length	mm	4150
Area with Rotor Feeder	m <sup>2</sup>	0.35
Separator area	m <sup>2</sup>	3.54
Wrap angle, rotor grate		150°
Speed	rpm	360 - 1000
Rotor fingers (for each rotor)	no.	38
Hatch in straw hood for cleaning rotor discharge		Yes
<b>Rear beater</b>		
Drive trains		Powerband belt
Speed	rpm	945
Wrap angle, concave		44°
Concave area	m <sup>2</sup>	0.34
Bars	no.	6
Clearance	mm	75
Wire diameter	mm	6

### 1.3.3 Cleaning unit

Cleaning unit	Units of measurement	FENDT 9490 X FENDT 9490 X AL
<b>Fanning Mill</b>		
Normal speed	rpm	460 ÷ 1150
Reduced speed	rpm	310 ÷ 790
Control		Variator belt
<b>Main grain pan</b>		
Type		Stepped plates, removable for cleaning
Movement		Alternating, opposite to bottom sieve
Con rod	strokes/min	295
Control		Double V-belts
Grain pan width	mm	1660
Grain pan length	mm	1680
Grain pan area	m <sup>2</sup>	2.79
Grain pan rake area	m <sup>2</sup>	0.4
<b>Top sieve</b>		
	no.	2
Upper sieve width	mm	813
Upper sieve length		1811
Top sieve area	m <sup>2</sup>	1.47
<b>Bottom sieve</b>		
	no.	2
Lower sieve width	mm	813
Lower sieve length	mm	1400
Bottom sieve area	m <sup>2</sup>	1.14
<b>Tailings</b>		
Type		Optional re-threshing
Conveyed by		Via tailings auger
Auger rotation speed	rpm	450 ÷ 800

**1.3.4 Grain tank**

Grain tank	Units of measurement	FENDT 9490 X FENDT 9490 X AL
Crop conveyed by		tank filling elevator and auger to the centre of the grain tank
Speed, tank filling elevator	rpm	450
Capacity	liters	12500 (AL 10500)
Unloading auger transmission		Powerband belt, chain and angle gear
Overload switch		Locking bolt
Unloading auger length	mm	5765 ÷ 6865
Unloading speed	liters/sec	120
Unloading height	mm	4300 ÷ 4800

### 1.3.5 Hydraulic system

Hydraulic system	Units of measurement	FENDT 9490 X FENDT 9490 X AL
Oil tank capacity (combined)	liters	36
<b>Auxiliary</b>		
<b>Revolution variator - Grain unloading auger (open/close)</b>		
Flow rate	liters/min	68
Max. pressure	bar	185
<b>Levelling - Shuttle - Table up/down - Reel up/down and fore/aft</b>		
Flow rate	liters/min	68
Max. pressure	bar	185
Filter on hydraulic tank	micron	16
<b>Threshing mechanism engagement- Grain unloading engagement - Feed mechanism engagement</b>		
Flow rate	liters/min	82
Max. pressure	bar	25
Filter on hydraulic tank	micron	16
<b>Reel speed</b>		
Flow rate	liters/min	27
Max. pressure	bar	155
Filter on hydraulic tank	micron	16
<b>Steering</b>		
Flow rate	liters/min	27
Max. pressure	bar	170 - 175
Filter on hydraulic tank	micron	16
<b>Chaff Spreader</b>		
Flow rate	liters/min	24
Max. pressure	bar	150
Filter on hydraulic tank	micron	16
<b>Motor for oil cooler fan</b>		
Flow rate	liters/min	20
Max. pressure	bar	60
Filter on hydraulic tank	micron	16

Hydraulic system	Units of measurement	FENDT 9490 X FENDT 9490 X AL
<b>Maxi-Spreader</b>		
Flow rate	liters/min	81
Max. pressure	bar	190
Filter	micron	12

### 1.3.6 Hydrostatic system

Hydrostatic system	Units of measurement	FENDT 9490 X FENDT 9490 X AL
Oil tank capacity (combined)	liters	36
Pump displacement	cm <sup>3</sup> /rev	145
Pump	rpm	2620
Pressure relief valve setting	bar	450
Motor displacement	cm <sup>3</sup> /rev	107
Return filter	micron	16

### 1.3.7 Engine

Engine	Units of measurement	FENDT 9490 X FENDT 9490 X AL
Make		AGCO POWER
Type		98 AWF 953
Cylinders	no.	7
Cubic capacity	cm <sup>3</sup>	9822
Bore	mm	111
Stroke	mm	145
Rotation direction (from the flywheel)		Anti-clockwise
Speed, idling	rpm	1000
Speed, fully loaded	rpm	2100
Speed at max. torque	rpm	1800
Rated power	kW	343 (at 2100 rpm)
Rated power with Power Boost (ECE R120)	kW	365 (at 2100 rpm)
Maximum output capacity	kW	360 (at 2000 rpm)
Maximum power with Power Boost (ECE R120)	kW	365 (at 1900 rpm)
Oil sump capacity	liters	33
Capacity of catalytic fluid (DEF) tank	liters	115
Fuel tank capacity	liters	1000
<b>Radiator</b>		
Circuit capacity	liters	56

**1.3.8 Electrical components**

Electrical components	Units of measurement	FENDT 9490 X FENDT 9490 X AL
<b>Battery</b>		
12 V type	A/h	200
Peak current	A	1200
<b>Starter motor</b>		
Type	V	12
<b>Alternator</b>		
Type	V	12
Charging capacity	A	150

**1.3.9 Gear oil**

Gear oil	Units of measurement	FENDT 9490 X FENDT 9490 X AL
Gearbox	liters	9.5
Hydraulic motor coupler housing	liters	1.5
Final drives	liters	6
Change of rotor	liters	1.5

### 1.3.10 Transmission

Transmission	Units of measurement	FENDT 9490 X FENDT 9490 X AL
Transmission type		With normal gearshift
Gears	no.	4
<b>Tires</b>		
Speed (moving forward and in reverse) with tires 710/75 R34		
1 <sup>st</sup> gear (work)	km/h	0 – 6.8
2 <sup>nd</sup> gear (work)	km/h	0 – 11.7
3 <sup>rd</sup> gear (work)	km/h	0 – 17
4 <sup>th</sup> gear (work)	km/h	–
4 <sup>th</sup> gear (driving on roads)	km/h	30 <sup>(1)</sup>
<b>Tracks (not available for AL models)</b>		
1 <sup>st</sup> gear (work)	km/h	0 – 6.10
2 <sup>nd</sup> gear (work)	km/h	0 – 10.5
3 <sup>rd</sup> gear (work)	km/h	0 – 17
4 <sup>th</sup> gear (work)	km/h	–
4 <sup>th</sup> gear (driving on roads)	km/h	30 <sup>(1)</sup>
<b>NOTE:</b> When driving on roads, the engine speed is adjusted to 1900 rpm.		

<sup>(1)</sup> This applies to all countries, except France, where the maximum speed is 25 kph.

### 1.3.11 Rear axle

Rear axle	FENDT 9490 X FENDT 9490 X AL
Type	adjustable
Four-Wheel Drive	Option

## 1.3.12 Weight

Unladen weights	Units of measurement	FENDT 9490 X	FENDT 9490 X AL
<b>Tires</b>			
Total weight of the 2 WD combine in gear order without table, with straw chopper and an empty grain tank	kg	18400	18900
Front weight	kg	9400	10000
Rear weight	kg	9000	8900
<b>Tracks (not available for AL models)</b>			
Total weight of the 2 WD combine in gear order without table, with straw chopper and an empty grain tank	kg	21000	–
Front weight	kg	12000	–
Rear weight	kg	9000	–

### Maximum weights technically permitted to travel on public roads

**NOTE:**

The following weights refer to Spanish/French type-approval and are displayed on the respective approval plate. For all other countries, please check the maximum weights listed in the vehicle registration documents.

Unladen weights	Units of measurement	Machines with tires	Machines with tracks
Total weight	kg	22500	22500
Front weight	kg	13000	13000
Rear weight	kg	9500	9500

**NOTE:**

The following weights refer to Italian type-approval and are displayed on the respective approval plate. For all other countries, please check the maximum weights listed in the vehicle registration documents.

Unladen weights	Units of measurement	Machines with tires	Machines with tracks
Total weight	kg	23200	25800
Front weight	kg	15200 – 16600	19200
Rear weight	kg	9500	9500

## 1.4 Wheels and tires

### 1.4.1 Wheel tightening torque

- Front wheel fastening elements: 700 Nm (71 kgm)
- Rear wheel fastening elements: 350 Nm (35 kgm)

Check the air pressure in the tires before using the machine for the first time. Check regularly thereafter.

Tighten the traction wheels before using the machine for the first time. Check the tightening torques regularly.

### 1.4.2 Tire capacity

Tire	Load index	Tire load capacity (kg) at 30 kph Road transport <sup>(1)</sup>	Tire load capacity (kg) at 10 km/h In field <sup>(2)</sup>
710/75 R34	178 A8	8025	12750
800/65 R32	178 A8	8025	12750
900/60 R32	176 A8	7595	12070
1050/50 R32	178 A8	8025	12750
IF680/85 R32	179 A8	8280	13165
IF800/65 R32	178 A8	8025	12750
IF800/70 R32	181 A8	8825	14025
500/70 R24	164 A8	4885	6200
500/60 R26.5	159 A8	4680	5225
600/55 R26.5	166 A8	5670	6575

<sup>(1)</sup> at the pressure indicated on the following pages

<sup>(2)</sup> according to ETRTO

### 1.4.3 Tire equipment

#### Front tires - FENDT 9490 X models

Tires	Rims	OFFSET (L/R flange) mm	Pressure with table PF 18-30 bar	Cutting table						Pressure with cutting table PF35 bar	Front wheels mm	Rear wheels (traction wheels) mm
				18	20	22	25	30	35			
710/75 R34 178A8	23 X 34	+46	3.2	X	X	X	X	X	X	3.8	3500	-
800/65 R32 178A8	27 X 32	-64	3.0	X	X	X	X	X	X	3.8	3860	-
900/60 R32 176A8	27 X 32	-64	2.7	X	X	X	X	X	-	-	3900	-
1050/50 R32 178A8	36 X 32	-144	2.4	X	X	X	X	X	X	2.7	4230	-
IF680/85 R32 179A8	21 X 32	+39	3.0	X	X	X	X	X	-	-	3500	-
IF800/65 R32 178A8	27 X 32	-64	2.4	X	X	X	X	-	-	-	3815	-
IF800/70 R32 181A8	27 X 32	-64	2.0	X	X	X	X	X	X	2.4	3815	-

#### Rear tires - FENDT 9490 X models

Tires	Rims	OFFSET (L/R flange) mm	Pressure with table PF 18-30 bar	Cutting table						Pressure with cutting table PF35 bar	Front wheels mm	Rear wheels (traction wheels) mm
				18	20	22	25	30	35			
500/70 R24 164A8	15 X 24	+42 (+10/4WD)	3.6	X	X	X	X	X	X	-	-	2985 (STD)
600/55 R26.5 166A8	20 X 26.5	-22 (0/4RM)	2.0	X	X	X	X	X	X	-	-	3110 (STD)

**Front tires - FENDT 9490 X AL models**

Tires	Rims	OFFSET (L/R flange) mm	Pressure with table PF 18-30 bar	Cutting table				Front wheels mm	Rear wheels (traction wheels) mm
				18	20	22	25		
710/75 R34 178A8	23 X 34	+46	3.2	X	X	X	X	3500	-
800/65 R32 178A8	27 X 32	-64	3.0	X	X	X	X	3860	-
IF800/65 R32 178A8	27 X 32	-64	2.4	X	X	X	X	3815	-
900/60 R32 176A8	27 X 32	-64	2.7	X	X	X	X	3900	-

**Rear tires - FENDT 9490 X AL models**

Tires	Rims	OFFSET (L/R flange) mm	Pressure with table PF 18-30 bar	Cutting table				Front wheels mm	Rear wheels (traction wheels) mm
				18	20	22	25		
500/70 R4 164A8 (4WD)	15 X 24	0	3.6	X	X	X	X	-	2955 (4WD)
600/55 R26.5 154A8 (4WD)	20 X 26.5	+37	2.0	X	X	X	X	-	3080 (4RM)

---

## 1.5 Safety Precautions

---

### 1.5.1 In general

---



**WARNING: This safety warning symbol means ATTENTION! BE ALERT! YOUR SAFETY IS INVOLVED.**

All operations described in this manual relating to repairs and maintenance must only be carried out by trained service personnel. The safety warning symbol highlights important safety messages on machines, safety signs, operator's manuals and elsewhere. When you see this symbol, be aware of the risk of personal injury or death. Follow the instructions in the safety message.

Why is SAFETY so important for you?

- ACCIDENTS CAN RESULT IN INJURY and DEATH.
- ACCIDENTS COST MONEY.
- ACCIDENTS CAN BE AVOIDED.

---

### 1.5.2 Safety in the workshop

---

This section on safety in your workshop manual is designed to point out some of the basic safety situations that can occur in the course of normal combine repairs, and to suggest possible ways of dealing with such situations.

Further measures may be needed, depending on the nature of the repair and the working conditions on site or in the workshop. AGCO has no direct control over repair methods, operation, inspection, lubrication or general maintenance. It is therefore YOUR responsibility to use good safety procedures in these areas.

---

### 1.5.3 Safety - a word to the mechanic

---

You are responsible for reading and understanding this chapter on safety before carrying out repairs on AGCO equipment.

Remember that YOU are the key to safety. Good safety routines protect not just you, but also the people around you. Study the principles in this chapter and make them part of your safety work. Follow all other general and supplier-specific safety precautions, and above all REMEMBER - YOU ARE RESPONSIBLE FOR SAFETY. YOU CAN PREVENT SERIOUS PERSONAL INJURIES OR DEATH.

---

### 1.5.4 Warnings

---

#### **Agricultural accidents can be prevented with your help.**

All accident prevention depends on the full co-operation of the persons using or involved with service or maintenance of the machine.

Most accidents can be avoided by observing simple safety rules.

**The best safety system** is one in which the operator observes all applicable regulations for machine safety and maintenance.

Some of the illustrations contained in this manual were obtained by photographing combine models of the same series, which may be differently equipped. This means that apparent discrepancies may result between your combine and those depicted in this manual.



**DANGER:** This symbol is used in this manual whenever your safety is involved.

**Take the time to read and follow the instructions. Most importantly, be careful!**

**You can never be too prudent.**

**In order to provide a better view, certain photographs or illustrations in this manual may show an assembly with the safety guards open or removed.**

**Fit and close all guards prior to machine operation.**

### Personal protection

Three types of warning signs appear in this manual and on the decals applied to the machine (**Caution**, **Warning** and **Danger**) followed by specific instructions or decals with symbols clearly illustrating the type of hazard.

These instructions involve your safety and the safety of people working nearby.

**Pay particular attention to these warnings.**



**CAUTION:** Indicates a potentially dangerous situation.

**If not avoided, it may result in minor injuries.**



**WARNING:** Indicates a potentially dangerous situation.

**If not avoided, it may result in serious injuries.**



**DANGER:** Indicates a potentially dangerous situation.

**If not avoided, it may result in very serious injuries or even death.**

Failure to follow the instructions related to the terms **Caution**, **Warning** and **Danger** may result in minor or serious injuries or even death.

### Machine safety

Other types of advice (**Note**, **Important**) are followed by special instructions referring to the safeguarding of the machine.

#### **NOTE:**

*Highlights and describes correct techniques or procedures to be adopted by the operator.*

#### **IMPORTANT:**

*Informs the operator that unless a special procedure is followed, damage, including serious damage, could be caused to the machine.*

---

## 1.5.5 Safety decals



**WARNING:** You must **NOT** remove or cover up danger, warning or instruction decals.

Replace any "DANGER", "WARNING", "CAUTION" or other instruction decals that are illegible, damaged or missing.

---

## 1.5.6 General

Nearly all maintenance work involves having to drive the combine. The operator's manual supplied with all combines or implements contains detailed safety precautions with regard to driving, operation and maintenance. These precautions apply to both the mechanic and driver/user and should be read, understood and practiced by all personnel.



**Suggest:**

**For more complete manuals. Please go to the home page.**

**<https://www.ebooklibonline.com>**

**If the above button click is invalid. Please download this document first, and then click the above link to download the complete manual.**

**Thank you so much for reading**

Before starting maintenance, repair, inspection, dismantling or assembly, whether in a workshop or "in the field", think about the factors that might affect safety, not just for the mechanic doing the work, but also for any onlookers.

- You must NOT allow children or onlookers to stand around or on the machine while you are adjusting, inspecting, repairing or driving it.

---

### **1.5.7 Personal safety**

---

#### **Clothing**

- Wearing the wrong clothes or dressing carelessly can cause accidents. Ensure that you are wearing suitable clothing. You must NOT wear loose-fitting garments or allow long hair to hang loose in the vicinity of the equipment.

Some jobs require special safety equipment to be worn.

#### **Eye protection**

- Even the tiniest eye injury could result in the loss of your sight. Injuries can be avoided by wearing safety glasses when chiseling, grinding, polishing, welding, painting, etc.
- Wear safety glasses of a type suitable for the work in question.

#### **Respiratory protection**

- Fumes, dust and spray paint are unpleasant and injurious to health. You can protect yourself against them by wearing respiratory protection.

#### **Hearing protection**

- Loud noise can damage your hearing, with the extent of the damage increasing with volume. If you think there is too much noise, wear hearing protection.

#### **Hand protection**

- The prior application of barrier creams is advised to prevent irritation and blackening of the skin. Wash your hands in soap and water after finishing work. Solvents such as white spirit, paraffin, etc., can damage the skin.
- Wear gloves whenever possible in order to protect your hands. You must NOT wear rings or wristwatches when working on the machinery, as these items can be caught in moving parts and cause serious injury.

#### **Foot protection**

- Strong or protective footwear with reinforced toecaps (safety shoes) can protect your feet from falling objects. Oil-resistant soles will also help stop you slipping.

#### **Safety clothing**

- It may be necessary to wear flame-retardant or acid-resistant clothing for certain types of work.

---

### **1.5.8 Considerations with regard to equipment**

---

#### **Machine safety**

- Before using a machine, you must check that the machine's guards are in place and functional. These guards not only prevent parts of the body or clothing from coming into contact with the machine's moving parts, but also stop objects that might fly off the machine and cause injury. Make sure that any missing guards are replaced.

### **Lifting equipment**

- Always make sure that lifting equipment such as chains, slings, lifting bars, hooks and eyes are inspected thoroughly before use. If you are in any doubt, choose stronger equipment than necessary.
- You must never stand under a suspended load or raised implement.
- Avoid injury as a result of components being handled incorrectly. Make completely sure that you can lift the object. If you are in any doubt, seek help.

### **Lifting with a jack**

- Choose a jack that is strong enough to take the load.
- Stabilize the combine and insert wedges under the wheels.
- Position support stands under the combine. Lower the jack and allow the combine to rest on the stands.
- You must NOT go under a combine that is being supported by a chain hoist or jack.

### **Compressed air**

- The pressure from a compressed air hose will often be up to 7 bar. This is completely safe if used correctly. Any misuse can cause injury.
- You must never use compressed air to blow dust, filings, dirt, etc., away from the area being worked on unless the right type of nozzle is fitted and safety glasses are being worn.
- Compressed air is not a cleaning agent and only moves dust, etc., from one place to another. Look around you before using a compressed-air hose, as onlookers may get grit in their eyes, in their ears and on their skin.
- Use approved air guns, safety glasses and suitable screening to protect other people in the area being worked on.
- You must never point an air nozzle at another person.

### **Hand tools**

- Many cuts, abrasions and injuries are caused by defective tools. You must never use the wrong tool for the job, as this generally results in either injury or poorly executed work.
- You must never use:
  - A hammer with a loose head or cracked handle.
  - Adjustable spanners, etc., with jaws rounded through wear or otherwise in a worn condition.
  - Spanners or files as a hammer, or bits, split pins and bolts as a punch.
  - Grind convex heads of chisels. The sharp edges can tear your skin if the tool slips. And when you strike the tool, chips can break off and fly into your eye.
- Make sure that you have a handle on every file to prevent the blade from going through your palm or wrist if the file were to slip or catch.
- For removing or changing hardened pegs, use a copper or brass punch rather than a hammer.
- The recommended special tools must always be used for dismantling, inspecting and joining large components.
- They will help reduce the time and effort required to carry out the work and minimize repair costs.
- Always keep tools clean and in good condition.

### **Always keep tools clean and in good condition.**

- Electricity has become so common in everyday use that its potential dangers are frequently overlooked. Misusing electrical equipment can have lethal consequences.
- Before using electrical equipment, especially portable devices, you must check that the cable is neither worn nor frayed and that plugs and sockets, etc., are intact. Make sure that you know where the nearest switch is located. Always use an electric cable with an earthed 3-pin plug.

**<https://www.ebooklibonline.com>**

Hello dear friend!

Thank you very much for reading.

Enter the link into your browser.

The full manual is available for immediate download.

**<https://www.ebooklibonline.com>**