



Large Square Baler

870N

870R

870S

990N

990R

990S

1270N

1270S

1290N

1290S

1290NXD

1290SXD

12130N

12130S

S/N: AGCFxxxxxEHB0x101 and After

TABLE OF CONTENT

- General 1
- Main frame 2
- Drive system 3
- Hydraulic system 4
- Electrical system 5
- Bale feeding system 6
- Bale forming system 7
- Accessories 8
- Diagrams 9

1. General

1.1 General information	1-5
1.1.1 Introduction to this service manual	1-5
1.1.2 Units of measurement	1-5
1.1.3 Table of contents	1-5
1.1.4 Page numbers	1-5
1.1.5 Installing a stake nut	1-5
1.1.6 Remove a gib key	1-6
1.1.7 Install a gib key	1-6
1.1.8 Remove a lock collar	1-7
1.1.9 Install a lock collar	1-7
1.2 Safety	1-9
1.2.1 Safety symbol	1-9
1.2.2 Safety messages	1-9
1.2.3 Information messages	1-9
1.2.4 Safety signs	1-9
1.2.5 Safety warnings	1-10
1.2.6 A word to the technician	1-10
1.2.7 The service manual	1-11
1.2.8 The operator manual	1-11
1.2.9 Toolbox	1-12
1.2.10 Operation	1-12
1.2.10.1 General information	1-12
1.2.10.2 Prepare for operation	1-13
1.2.10.3 Personal protective equipment	1-14
1.2.10.4 Seat instructions	1-14
1.2.10.5 Shield and guards	1-14
1.2.10.6 Exhaust warning	1-15
1.2.10.7 Flying debris	1-15
1.2.10.8 Handrails	1-16
1.2.10.9 Agricultural chemicals	1-16
1.2.11 Travel on public roads	1-16
1.2.12 Maintenance	1-18
1.2.12.1 General maintenance information	1-18
1.2.12.2 Fire prevention and first aid	1-20
1.2.12.3 High pressure leaks	1-21
1.2.12.4 Accumulator safety	1-22
1.2.12.5 Tire safety	1-22
1.3 Specifications	1-23
1.3.1 Dimensions and weights	1-23
1.3.2 Drive system specifications	1-24
1.3.3 Shearbolt specifications	1-25
1.3.4 Hydraulic specifications - on board	1-26
1.3.5 Pickup specifications	1-26
1.3.6 Rotor cutter specifications - early production	1-27
1.3.7 Rotor cutter specifications - late production	1-28
1.3.8 Packer specifications	1-29
1.3.9 Packer/cutter specification, if equipped	1-29
1.3.10 Stuffer specifications	1-29
1.3.11 Plunger specifications	1-30
1.3.12 Twine specifications	1-30
1.3.13 Knotter and needle specifications	1-31

<https://www.ebooklibonline.com>

Hello dear friend!

Thank you very much for reading.

Enter the link into your browser.

The full manual is available for immediate download.

<https://www.ebooklibonline.com>

1.3.14	Bale chamber tension specifications	1-31
1.3.15	Ejector specifications	1-31
1.3.16	Roller bale chute specifications, if equipped	1-32
1.3.17	Lamp specification	1-32
1.3.18	Knotter lubrication pump specifications	1-32
1.3.19	Chain lubrication pump specifications, if equipped	1-33
1.3.20	Lubricants and capacities	1-33
1.3.21	Tire specifications	1-34
1.3.22	Brake specifications, if equipped	1-35
1.3.23	Maximum speed	1-37
1.3.24	Tractor requirements	1-37
1.3.25	Noise levels	1-38
1.4	Bolt torque values	1-39
1.5	Machine identification	1-41
1.5.1	Serial number plate location	1-41
1.5.2	Serial number description	1-42
1.6	Machine components	1-43
1.6.1	Outside view - left-hand side	1-43
1.6.2	Outside view - right-hand side	1-44
1.6.3	Inside view - left-hand side	1-45
1.6.4	Inside view - right-hand side	1-46
1.6.5	Description of operation	1-46
1.7	Service schedule	1-48
1.8	Lubrication points	1-52
1.8.1	Driveline lubrication and maintenance	1-52
1.8.1.1	Removing and installing the implement driveline shields	1-53
1.8.2	Lubricating the hitch ball, if equipped	1-54
1.8.3	Lubricating the main drive slip clutch	1-54
1.8.4	Lubricating the overrunning clutch	1-55
1.8.5	Lubricating the flywheel bearing	1-55
1.8.6	Lubricating the connecting rods	1-55
1.8.7	Lubricating the packer crank bearings	1-56
1.8.8	Inspecting the packer crank bearings	1-57
1.8.9	Lubricating the packer/cutter crank bearings	1-57
1.8.10	Inspecting the packer/cutter crank bearings	1-57
1.8.11	Lubricating the cutter rotor clutch, if equipped	1-58
1.8.12	Lubricating the anchor for the rotor cutter chain tensioner	1-58
1.8.13	Lubricating the rotor cutter bearings	1-59
1.8.14	Lubricating the knife cranks, if equipped	1-59
1.8.15	Lubricating the main drive sprocket	1-60
1.8.16	Lubricating the stuffer drive	1-60
1.8.17	Lubricating the knotter/needle clutch	1-61
1.8.18	Lubricating the brake linkage	1-61
1.8.19	Lubricating the tandem axle pivot bushings	1-62
1.8.20	Lubricating the metering wheel shaft	1-62
1.8.21	Lubricating the six twine knotter center fitting	1-62
1.8.22	Lubricating the tucker arm and twine arm cam rollers	1-63
1.8.23	Lubricating the bale density cylinders	1-63
1.8.24	Lubricating the packer clutch	1-64
1.8.25	Lubricating the main packer/cutter crank bearing	1-64
1.8.26	Lubricating the packer/cutter chain tensioner	1-64
1.8.27	Lubricating the pickup overrunning clutch	1-65
1.8.28	Lubricating the pickup linkage roller	1-65
1.8.29	Lubricating the pickup spring pivot	1-66
1.9	Connecting to the tractor - CE	1-67
1.9.1	Removing the shipping bracket	1-67
1.9.2	Hitch component identification	1-67

1.9.3 Baler height setting	1-68
1.9.4 Tractor setup dimensions with an 80 mm (3.15 in) ball hitch, a CE spherical ball hitch, or a 50 mm (2 in) ring hitch	1-68
1.9.5 Tractor setup dimensions with a 40 mm (1.6 in) high ring hitch	1-69
1.9.6 Installing the machine hitch	1-69
1.9.7 Connecting the machine hitch to the tractor drawbar	1-71
1.9.8 Connecting a 50 mm (2 in) ring hitch to the tractor	1-72
1.9.9 Connecting an 80 mm (3.15 in) ball hitch to the tractor	1-72
1.9.10 Connecting a 40 mm (1.6 in) high ring hitch to the tractor	1-72
1.9.11 Operating a hydraulic tongue jack	1-73
1.9.12 Installing the safety transport chain	1-73
1.9.13 Constant velocity implement driveline, if equipped	1-74
1.9.13.1 Connecting a quick disconnect yoke to a power take off	1-74
1.9.13.2 Making marks on the constant velocity implement driveline	1-75
1.9.13.3 Checking the constant velocity implement driveline angle	1-76
1.9.13.4 Adjusting the constant velocity implement driveline angle	1-76
1.9.13.5 Checking the constant velocity implement driveline clearance	1-77
1.10 Checklists	1-78
1.10.1 Daily checklist	1-78
1.10.2 Inspection after the first hour of operation	1-78
1.11 Lighting and reflectors - CE	1-79
1.11.1 Lighting and reflectors	1-79
1.12 Lighting and reflectors - NA	1-80
1.12.1 Lighting and reflectors	1-80
1.13 Baler operation	1-81
1.13.1 Preparing to bale	1-81
1.13.2 Starting the baler	1-81
1.13.2.1 The plunger is away from the bale	1-81
1.13.2.2 The plunger is near or on the bale	1-81
1.13.2.3 Baler fails to start	1-82
1.13.3 Baling the first bale	1-82
1.13.4 Baling	1-83
1.13.5 Stopping the baler	1-83
1.14 Preparing to road the machine or to move the machine on a trailer	1-85
1.15 Lifting and tie down	1-88
1.15.1 Lift a baler correctly	1-88
1.15.2 Lifting points	1-88
1.15.3 Tie down points	1-89
1.16 Air brake pressure release	1-91
1.17 Disconnecting the tractor	1-92

1.1 General information

1.1.1 Introduction to this service manual

This service manual gives information from engineering tests, operating data, and the latest service techniques at the time of publication. Read this service manual carefully before doing any service on the machine.

The photos and illustrations used in this service manual were current at the time of publication. Production changes can cause machines to vary from the photos and the illustrations. The manufacturer reserves the right to redesign and change machines as necessary without notification.

**WARNING:**

Some pictures in this manual show the machine with shields or guards removed to permit for a better view of the subject of the picture. All shields and guards must be in position before operating the machine.

Machine movement when in normal use determines right-hand and left-hand.

1.1.2 Units of measurement

Measurements are given in metric units followed by the equivalent in US units. Hardware sizes are given in millimeters for metric hardware and inches for US hardware.

1.1.3 Table of contents

This manual has a table of contents at the front. The table of contents shows the divisions. The individual divisions also have a table of contents.

1.1.4 Page numbers

All pages have two numbers, such as 01-25. The first number shows the division. The second number shows the page in the division.

Page numbers occur on the lower right-hand or lower left-hand corner of each page.

1.1.5 Installing a stake nut

Procedure

1. Install the stake nut (2) onto the shaft (4).
2. Stake the flange on the stake nut into the groove (3) in the roller shaft.
 - a) Use an 8 mm diameter punch (1) that has a spherical end.
 - b) Grind a small flat area at the end of the punch.
 - c) Put the flat area against the face of the stake nut.
 - d) Drive the flange of the stake nut into the groove (3) 0.75 to 1.25 mm (0.030 to 0.049 in).

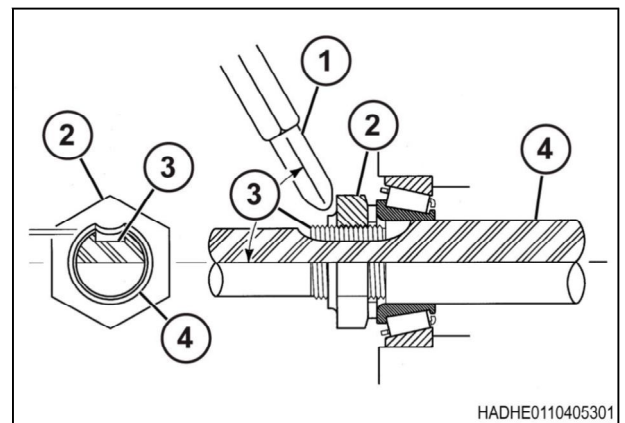

Fig. 1

IMPORTANT: Driving the flange into the bottom of the groove will damage the stake nut.

3. Inspect the staked area of the stake nut for cracks. Replace the stake nut if cracks are present.

1.1.6 Remove a gib key

Gib keys are tapered keys with a tang on the thick end. A gib key is both a locking component and a hub retainer. The hub must have a tapered key way that fits the gib key. The gib key will lock the hub into position requiring no other locking component such as a set screw.

Procedure

1. Remove paint from both sides of the of the gib key (1).
2. Use a crowbar (2) to apply pressure between the gib key and the hub (3). Drive the hub away from the gib key by hitting the hub with a hammer (4).

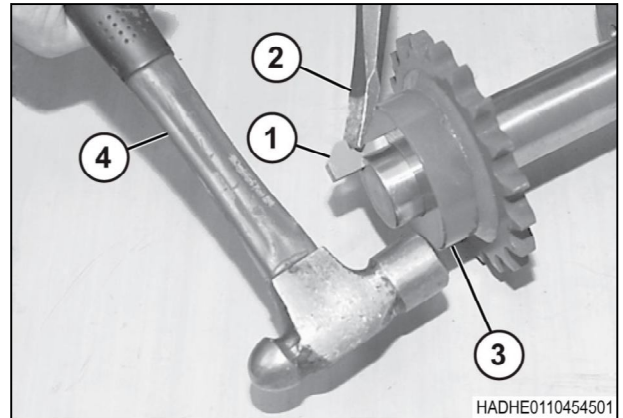

Fig. 2

3. Make a special tool to remove gib keys that are not easily accessible:
 - a) Get a 25 mm wide chisel (1) and grind the width (2) of the chisel to 16 mm.
 - b) Grind a slot (3) in each side of the head of the chisel. The slot keeps the chisel from slipping.

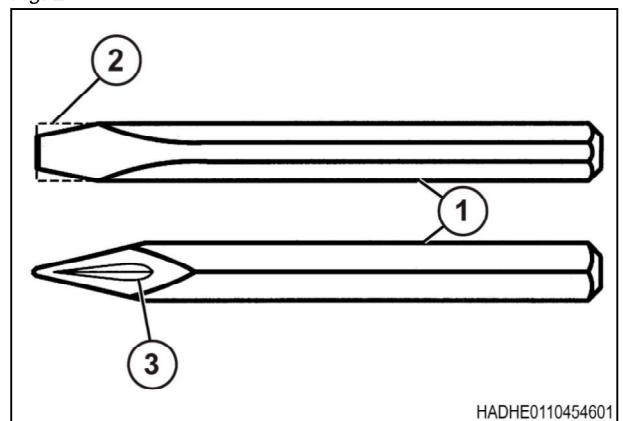

Fig. 3

4. Put the special tool between the gib key head (1) and the hub (2).
5. Drive against the special tool with a hammer.
6. Use the narrow side (3) of the special tool for smaller gib keys and the wide side (4) for large gib keys.
7. After the hub and the gib key loosen, remove the gib key with a crowbar.
8. Remove the hub.

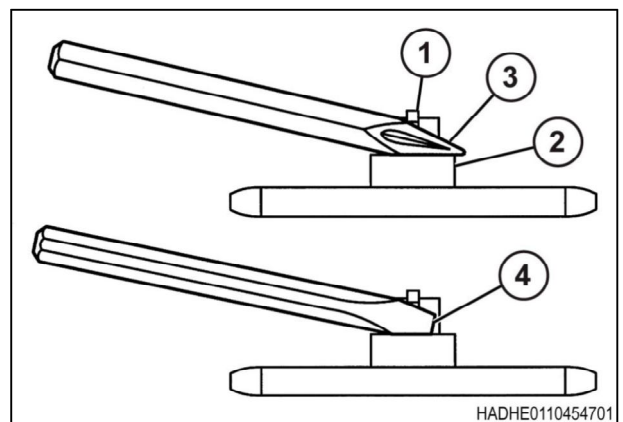

Fig. 4

1.1.7 Install a gib key

Gib keys are tapered keys with a tang on the thick end. A gib key is both a locking component and a hub retainer. The hub must have a tapered key way that fits the gib key. The gib key will lock the hub into position requiring no other locking component such as a set screw.

Procedure

1. Put a thin layer of antiseize or grease on the shaft (1) to keep the hub (2) and shaft from sticking together.
2. Install the hub. Make sure the taper in the hub is in the same direction as the gib key (3) taper.
3. Align the keyway in the hub with the keyway in the shaft.
4. Install the gib key.
5. Hold the sheave or sprocket in position on the shaft.
6. Hit the gib key with a hammer until the gib key seats.

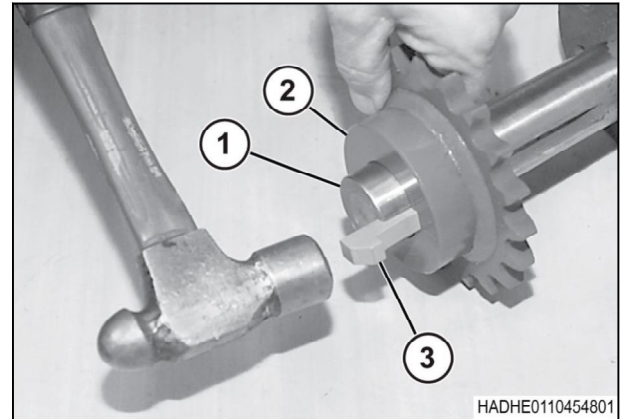

Fig. 5

IMPORTANT:

Do not hit the gib key extremely hard while installing.

1.1.8 Remove a lock collar**Procedure**

1. Loosen the set screw (4).
2. Put a punch into into the pin hole (5).
3. Use a hammer to tap the punch to turn lock collar (2). Turn the lock collar in the opposite direction of the shaft rotation.
4. Remove the lock collar from the inner race (3) of the bearing (1).

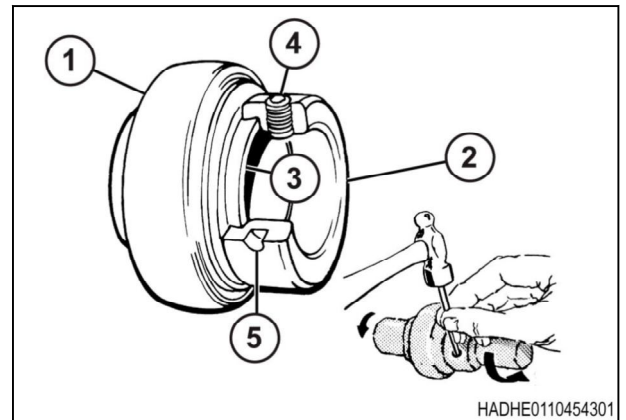

Fig. 6

1.1.9 Install a lock collar

Sealed ball bearings are held in position on many shafts with lock collars. The lock collar has an eccentric counterbore. This counterbore engages the end of the bearing inner race when the bearing is assembled. The lock collar is turned on the bearing to lock the assembly on the shaft. That assembly holds the shaft tightly with a positive lock effect that increases with use. A set screw in the lock collar applies more lock pressure.



Suggest:

For more complete manuals. Please go to the home page.

<https://www.ebooklibonline.com>

If the above button click is invalid. Please download this document first, and then click the above link to download the complete manual.

Thank you so much for reading

1. General

Procedure

1. Install the bearing (1), move the lock collar (2) onto the shaft.
2. Push the lock collar against the bearing inner race (3).
3. Turn the lock collar in the direction of the shaft rotation until tightly engaged.
4. To tighten the lock collar, put a punch in the pin hole (5) and tap the punch with a hammer.

NOTE: Always tighten the lock collar in the same direction of the shaft rotation.

5. Tighten the set screw (4) to the correct specification in the lock collar.

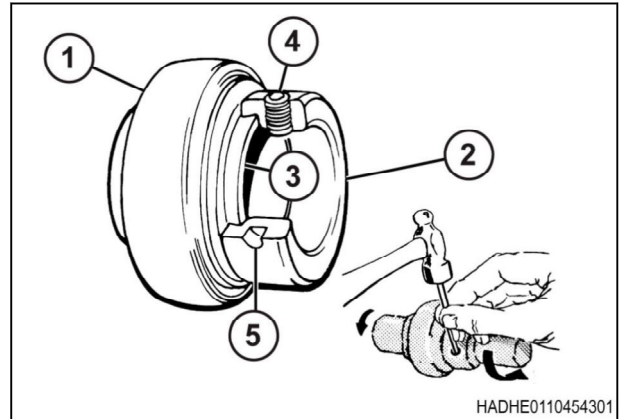

Fig. 7

Set screw size	Torque specification
1/4 - 20	4.8 Nm
5/16 - 18	18 Nm
3/8 - 16	31 Nm
7/16 - 14	49 Nm

1.2 Safety

1.2.1 Safety symbol

The safety symbol tells you about a dangerous area!

Look for the safety symbol in this manual and on the machine. The safety symbols tell you that there is important safety instructions in the manual.



Fig. 8

1.2.2 Safety messages

The words DANGER, WARNING or CAUTION are used with the safety symbol. Learn these safety messages and obey the recommended precautions and safety instructions.



DANGER:
If you do not obey the recommended precautions and safety instructions, **DEATH OR INJURY will occur.**



WARNING:
If you do not obey the recommended precautions and safety instructions, **DEATH OR INJURY can occur.**



CAUTION:
If you do not obey the recommended precautions and safety instructions, **INJURY can possibly occur.**



Fig. 9

1.2.3 Information messages

The words important and note are not related to personal safety, and are used to give information about the operation and servicing of the machine.

IMPORTANT: Identifies special instructions or procedures which, if not followed, can cause damage to the machine, the process, or the area around the machine.

NOTE: Information to make procedures easier.

1.2.4 Safety signs



WARNING:

Do not remove the safety signs. Replace safety signs that you cannot read, are damaged, or are missing. Clean the machine surface with a weak soap and water solution before you replace the safety signs. Replacement safety signs are available from your dealer.

<https://www.ebooklibonline.com>

Hello dear friend!

Thank you very much for reading.

Enter the link into your browser.

The full manual is available for immediate download.

<https://www.ebooklibonline.com>