

KOBELCO

SERVICE MANUAL

mitsubishi DIESEL ENGINE

6D34-T

(For industrial use)



Shop Manual

diesel engine

6D34-T (for industrial use)

6D34-T

diesel engine

Shop Manual

(for industrial use)

FOREWORD

This Shop Manual is published for the information and guidance of personnel responsible for maintenance of Mitsubishi 6D34-T series diesel engine, and includes procedures for adjustment and maintenance services.

We earnestly look forward to seeing that this manual is made full use of in order to perform correct service with no wastage.

For more details, please consult your nearest authorized Mitsubishi dealer or distributor.

Kindly note that the specifications and maintenance service figures are subject to change without prior notice in line with improvement which will be effected from time to time in the future.

Applicable models
6D34-T

GROUP INDEX

HOW TO READ THIS MANUAL

GENERAL	00
ENGINE	11
LUBRICATION	12
FUEL AND ENGINE CONTROL ...	13
COOLING	14
INTAKE AND EXHAUST	15
ELECTRICAL SYSTEM	54
SPECIAL EQUIPMENT	61

<https://www.ebooklibonline.com>

Hello dear friend!

Thank you very much for reading.

Enter the link into your browser.

The full manual is available for immediate download.

<https://www.ebooklibonline.com>

HOW TO READ THIS MANUAL

This manual is intended to provide information to the public regarding the rules and regulations of the Department of Education. It is not intended to provide legal advice or to be used as a substitute for legal counsel.

HOW THIS MANUAL IS COMPILED	ii
GENERAL EXPLANATION OF THIS MANUAL	iii
TERMS AND UNITS	vii

HOW TO READ THIS MANUAL

How This Manual Is Compiled

- This manual is compiled by classifying various systems into certain groups.
- Each group contains specifications; troubleshooting; maintenance service standards; ⚙ tightening torque; ⚙ lubricant, fluid and sealant; 🛠 special tools; and service procedure.
- Page enumeration is independent by every group where first page is always 1.

Group No.	Group denomination	Contents
00	General	General specifications, engine No. and name plate, precautions for maintenance operations, table of standard tightening torques
11	Engine	Engine body
12	Lubrication	Lubrication system
13	Fuel and engine control	Fuel system
14	Cooling	Cooling system
15	Intake and exhaust	Intake and exhaust system, air cleaner, turbocharger
54	Electrical system	Starter, alternator, preheating system, engine start system
61	Special equipment	Air compressor, pressure governor

General Explanation of This Manual

● Specifications

Particulars relative to maintenance service are made.

● Structure and operation

- (1) Regarding conventional equipment, descriptions are made in brief.
- (2) Regarding new equipment, descriptions of system and operating condition are made in detail.

● Troubleshooting

Symptoms of troubles and possible causes are described comparatively.

● Inspection and adjustment mounted in vehicle

Descriptions are made regarding inspection and adjustment of units mounted in vehicle.

● Service procedure

In principle, an explanation is given at the spread title page so that the service procedure can be understood. Servicing points are explained as a supplementary explanation.

Regarding the design of this manual

CLUTCH BODY

Pressure Plate and Lever Assembly

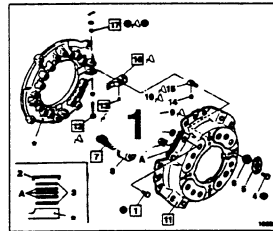

● Disassembly sequence

- 1 Bolt
- 2 Washer
- 3 Washer
- 4 Bolt
- 5 Lo
- 6 Oil
- 7 Pin
- 8 Pressure spring cap
- 9 Return spring
- 10 Release lever plate
- 11 Clutch cover
- 12 Release lever pin
- 13 Support lever pin
- 14 Bearing
- 15 Support lever
- 16 Release lever
- 17 Bearing

● Assembly sequence

- 1 Pressure plate & lever assembly
- 2 21-21-12
- 3 Clutch disc

- Flywheel
- A: Positioning pin (at 2 places)
- ⊙: Non-reusable part

● Assembly sequence

- 14 → 15 → 13 → 16 → 17 → 1 → 7 → 6 → 8 → 4 → 3 → 2 → 1
- Repair MC clutch release

Service standards

Location	Maintenance item	Standard value (Basic dimension in [])	Limit	Remedy
1, A	Clutch release strap bolt and strap plate	0.01 to 0.18	0.3	Replace
7	Pressure spring Installed load (pretension length 46.1)	890 N (92.2 kg)	750 N (75.7 kg)	Replace
		2.8 or less	5.0	Replace
10	Clearance in ver pin and bushing	[10] 0.08 to 0.18	0.4	Replace
10	Release lever	13.6 ± 0.7	Neutral clearance 0.8 or less	Adjust

● Tightening torques

Location	Parts to be	Tightening torque	Remarks
1	Strap bolt loosening oil	38 to 68 (4 to 6)	—
4	Bolt loosening oil	5.8 to 7.9 (0.6 to 0.8)	Wet

▲ Lubricants

Location	Points of application	Notes	Quantity
1	Threads of strap bolt	LOCTITE #12	As required
10, 10	Sliding surfaces of lever	4	Multipurpose chassis grease
12, 17	Sliding surfaces of pins	Washing	Multipurpose chassis grease
15, 14	Sliding surfaces of bush	Apply lever	Multipurpose chassis grease (No. 2 oil spray)

● Special tools

Location	Tool name and shape	Part No.	Application
11	Clutch tester	4P-987000 P27	Pressure and installation of clutch cover
10	Clutch Master Plate	4P-988000 1000	Release lever plate height adjustment

● Service procedure

- 1 A Clearance between strap bolt and strap plate

If the measurement exceeds the limit, replace the defective part.

A: Strap plate

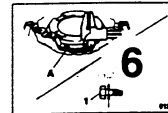

- 2 Installation of pressure spring

If pressure plate 10 has been replaced, insert adjusting member A corresponding to the amount of sag in the space between the pressure plate and pressure spring 7.

Adjusted amount	Type and no. of washers
Less than 1 mm	Not required
1 mm or more to less than 2 mm	One 1.2-mm
2 mm or more to less than 3 mm	Two 1.2-mm or one 2.5-mm

1. Illustration for disassembly and assembly or removal and installation: 3-D exploded view of component parts is displayed.
- 1a. Names of parts show an example of the disassembly (removal) sequence.
- 1b. When the assembly (installation) sequence differs from the disassembly (removal) sequence, an example of the assembly (installation) sequence is shown.
2. Service standards are shown collectively, classified by location.
3. Tightening torques are shown collectively, classified by location.
4. Points of lubricant, fluid and sealant application are shown collectively, classified by location.
5. Special tools to be used are shown collectively, classified by location.
6. When it is considered hard to understand the service procedure, just by the foregoing description, a supplementary description of the service procedure is given.

HOW TO READ THIS MANUAL

1. Illustration for disassembly and assembly or removal and installation

This shows that the appropriate service procedure is described in the text.

This shows the key No. of the part. In the text, this No. is referred to uniformly throughout.

This shows an example of the disassembly (removal) sequence.

This shows that the service procedure is described in another section.

: shows reference page within the same group.

: shows reference group within the same book.

No service procedure is referred to in this section, but the item can be an objective of various procedures.

This is shown when the assembly (installation) sequence is not the reverse of the disassembly (removal) sequence.

This shows that a repair kit is available.

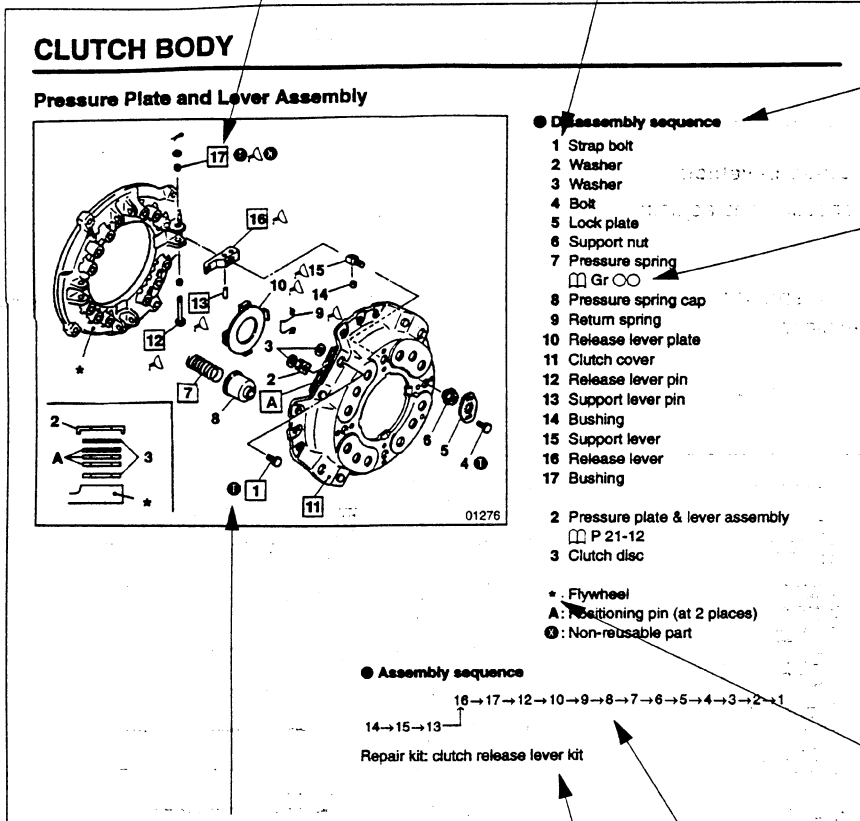

Meaning of symbols

- : shows that the tightening torque is specified.
- : shows that application of lubricant, fluid or sealant is required.
- : shows that the part should not be reused.

2. Service standards table

Only the relevant service standards are shown.

Service standards

Unit: mm

Location	Maintenance item	Standard value	Limit	Remedy
1, 11	Clearance between strap bolt and strap plate	0.01 to 0.16	0.3	Replace
7	Pressure spring	Installed load (Installed length 49.1)	710 N (72.3 kgf)	Replace
		Tilt	2.9 or less	Replace

This shows the key No. of the relevant part.

3. Tightening torque table

This shows specified tightening torque.

Tightening torque

Unit: N · m (kgf · m)

Location	Parts to be tightened	Tightening torque	Remarks
1	Strap bolts (Strap bolt mounting)	39 to 59 {4 to 6}	—
4	Bolt (Lock plate mounting)	5.9 to 7.8 {0.6 to 0.8}	Wet

This shows the key No. of the relevant part.

This shows that the item is to be tightened wet.

4. Lubricant, fluid and sealant table

Only the relevant lubricant, fluid and sealant are shown.

This shows the application point.

Lubricant, fluid and sealant

Location	Points of application	Type	Quantity
1	Thread area of bolt	LOCTITE 272	As required
10, 16	Friction surfaces of release lever plate and release lever	Molybdenum disulfide grease [NLGI No. 2 (Li soap)]	As required

This shows the key No. of the relevant part.

This shows the specified brand.

HOW TO READ THIS MANUAL

5. Special tools table

Only the relevant special tools are shown.

Purpose of special tools is shown.

Special tools

Unit: mm

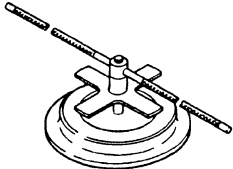
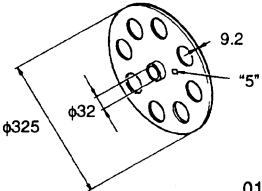
Location	Tool name and shape	Part No.	Application
11	Clutch installer 	MH061051	Removal and installation of clutch cover
16	Master plate 	MH062291	Adjust release lever heights

This shows the key No. of the relevant part.

Quote this number when placing an order for the part.

6. Service procedure

This indicates a special service tool.

This shows the key No. of the relevant part.

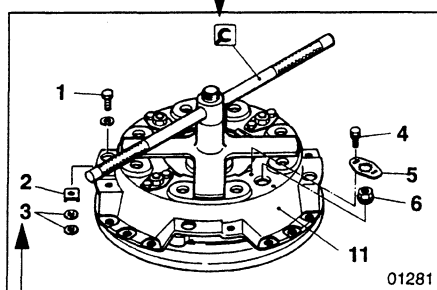

11 Removal and installation of clutch cover

- Depress pressure spring 7 using  clutch installer, then remove the following parts:
Strap bolt 1, washer 2, washer 3, bolt 4, lock plate 5, support nut 6
- Loosen the clutch installer gradually, then remove clutch cover 11 when the pressure spring is fully released.
- For installation, follow the removal sequence in reverse.

The key No. referred to in the text is always the same as the key No. shown in the illustration.

Servicing procedures of disassembly (removal), assembly (installation), inspection, adjustment, etc. are shown collectively.

Terms and Units

The terms and units in this manual are defined as follows.

- This service manual contains important cautionary instructions and supplementary information under the following four headings which identify the nature of the instructions and information:

DANGER  ————— Precautions that should be taken in handling potentially dangerous substances such as battery fluid and coolant additives.

WARNING  ————— Precautionary instructions, which, if not observed, could result in serious injury or death.

CAUTION  ————— Precautionary instructions, which, if not observed, could result in damage to or destruction of equipment or parts.

NOTE ————— Suggestions or supplementary information for more efficient use of equipment or a better understanding.

● Front and rear

The terms “front” is the fan side and “rear” the flywheels side of the engine.

● Left and right

The terms “right” and “left” shall be used to indicate the side as viewed from the flywheel side of the engine.

● Terms of service standards

(1) Standard value

Standard value dimensions in designs indicating: the design dimensions of individual parts, the standard clearance between two parts when assembled, and the standard value for an assembly part, as the case may be.

The figure in [] is the basic diameter.

(2) Limit

When the value of a part exceeds this, it is no longer serviceable in respect of performance and strength and must be replaced or repaired.

● Tightening torque

Excessive or insufficient tightening torque has particular importance in respect of performance. Accordingly, tightening torque is specified in locations that are to be tightened.

Where there is no specified figure for tightening torque, follow the table covering standard tightening torques.

When the item is to be tightened in a wet state, wet is indicated. Where there is no indication, read it as dry, and tighten at specified torque.

HOW TO READ THIS MANUAL

● Unit

Length, weight, surface area and capacity are in SI units. Imperial and metric units are given in brackets. Temperatures are given in degrees Celsius with degrees Fahrenheit given brackets.

For the conversion into the foot-pound system, refer to the following conversion table.

Unit	Sign of SI unit	Sign of foot-pound unit	Conversion rate
Mass quantity of matter	kg	lb	1 kg = 2.2046 lb
	g	oz	1 g = 0.035274 oz
Dimension	m	ft.	1 m = 3.2808 ft.
	mm	in.	1 mm = 0.03937 in.
Capacity	L	gal.	1 L = 0.2642 gal. (U.S.) 1 L = 0.220 gal. (Imp.)
	cm ³	oz	1 cm ³ = 0.033814 oz (U.S.)
	cm ³	cu.in.	1 cm ³ = 0.035195 oz (Imp.) 1 cm ³ = 0.061023 cu.in.
Force	N (Newton)	lbf	1 N = 0.2248 lbf
Pressure	kPa (kilopascal)	lbf/in. ²	1 kPa = 0.145 lbf/in. ²
			1 kPa = 0.2953 in. Hg
Stress	N/cm ²	lbf/in. ²	1 N/cm ² = 1.45 lbf/in. ²
Moment of force	N · m	lbf.ft	1 N · m = 0.7375 lbf.ft
Output	kW (kilowatt)	HP	1 kW = 1.34 HP
Temperature	°C	°F	t°C = (1.8t°C + 32)°F

GROUP 00 GENERAL

GENERAL SPECIFICATIONS 00-2

ENGINE NUMBER, NAME PLATE AND CAUTION PLATE ... 00-3

PRECAUTIONS FOR MAINTENANCE OPERATION 00-4

TABLE OF STANDARD TIGHTENING TORQUES 00-11

GENERAL SPECIFICATIONS

Major Specifications

Item	Specifications
Engine model	6D34-T
Type	6-cylinder in-line, water-cooled 4-cycle diesel
Combustion chamber type	Direct injection type
Valve mechanism	Overhead valve (OHV) type
Maximum output KW/rpm {PS/rpm}	Depends on the engine specification
Maximum torque N · m/rpm {kgf · m/rpm}	
Bore × Stroke mm	104 × 115
Total displacement cc	5861
Compression ratio	16.5
Empty mass kg*	450

* Empty mass as measured according to Mitsubishi Motors Corporation standard.

Engine Outputs Classified by Application

Item	Engine speed rpm	Specifications
Intermittent rated output kW (HP)	1500	115
	1800	138
	2000	153
	2200	159
	2500	162

NOTE:

- The output (SAE, gross) is corrected to standard ambient conditions based on SAE J1349.
- The continuous rated output allows 10% (one hour) overload operation.

ENGINE NUMBER, NAME PLATE AND CAUTION PLATE 00

The serial number for engine is assigned to the respective engine in manufacturing sequence: every engine has its own number. This number is required for incidental inspection of the engine. Please do not fail to mention this number to the dealers when ordering spare parts.

Engine Number

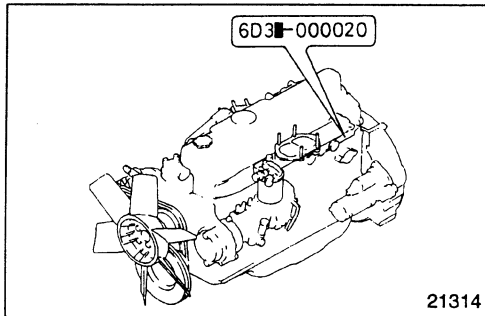

The engine number is punch-marked on the shown location.

Name Plate and Caution Plate

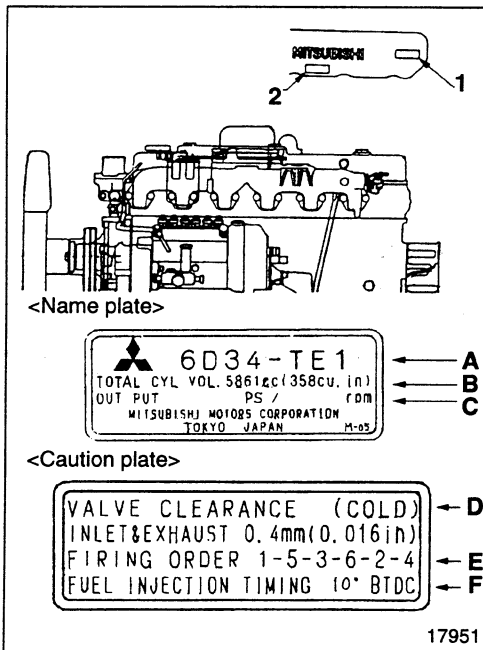

- 1: Name plate
- 2: Caution plate

- A Engine model
- B Total displacement
- C Maximum output
- D Valve clearance
- E Firing order
- F Fuel injection timing

PRECAUTIONS FOR MAINTENANCE OPERATION

In order to determine the condition of the vehicle adequately, attend the vehicle beforehand to find and keep record of the accumulated mileage, operating condition, what the customer's demand is, and other information that may be necessary. Prepare the steps to be taken and perform efficient and wasteless maintenance procedure.

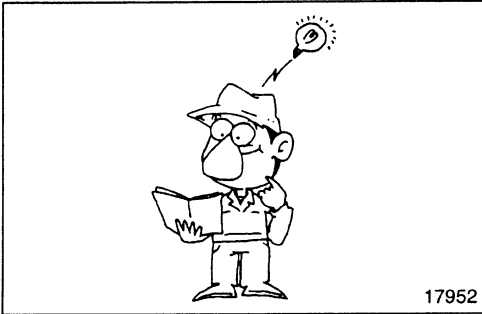

- Determine where the fault exists and check for the cause to see whether removal or disassembly of the part is necessary. Then follow the procedure specified by this manual.
- Perform maintenance work at a level area.

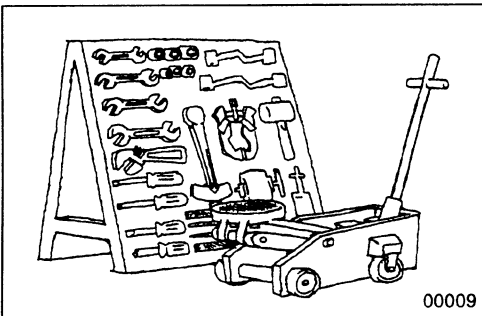

- Prepare general and special tools necessary for the maintenance work.

WARNING ⚠

Do not attempt to use tools other than special tools where use of special tools is specified in this manual. This will avoid injury or damage.

- When removing or installing the engine, attach the lifting wire rope hooks to the engine's lifting eyes and hoist the engine slowly such that it does not touch other components.

WARNING ⚠

Check that the wire rope and crane are sufficiently strong.



- Be particularly careful not to work in shoes that have oily soles and are slippery. When working as a team of two or more, arrange signals in advance and keep confirming safety. Be careful not to accidentally bump switches or levers.
- Check for oil leakage before cleaning the area having the fault otherwise you might miss detecting the leakage.
- Prepare replacement part(s) beforehand.

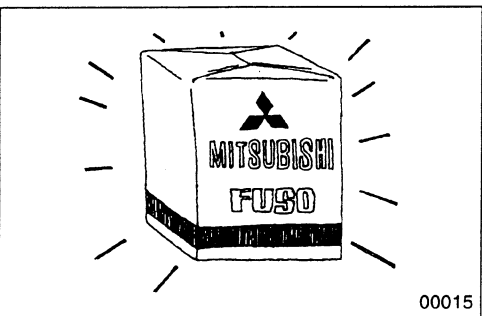

- Replace oil seals, packing, O-rings and other rubber parts; gaskets and split pins with new parts whenever any of them has been removed. Use only genuine MITSUBISHI replacement parts.

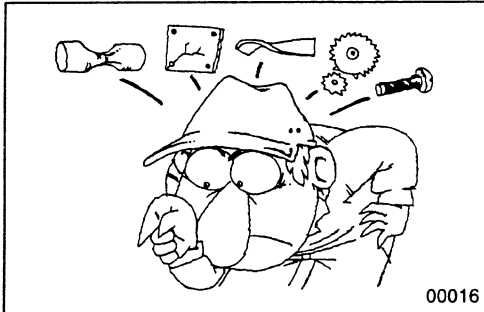

00016

On disassembly, visually inspect all parts for wear and tear, cracks, damage, deformation, degradation, rust, corrosion, smoothness in rotation, fatigue, clogging and any other possible defect.

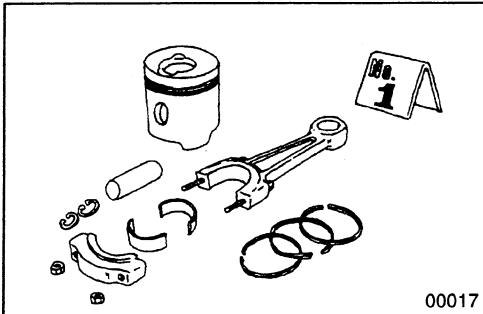

00017

Put alignment marks on part combinations before disassembly and arrange the disassembled parts neatly. This will help avoid mismatching of the parts later.

Put the alignment marks, punch marks, etc. where performance and appearance will not be affected.

Cover the area left open after removal of parts to keep it free from dust.

CAUTION ⚠

- Take care to avoid mixing up numerous parts, similar parts, left and right, etc.
- Keep new parts for replacement and original (removed) parts separate.

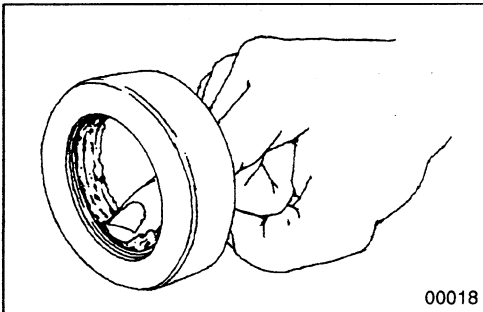

00018

Apply the specified oil or grease to U-packings, oil seals, dust seals and bearings during assembly.

CAUTION ⚠

Use only the specified oil, grease, etc. for lubricant. Remove the excess immediately after application with a piece of rag.

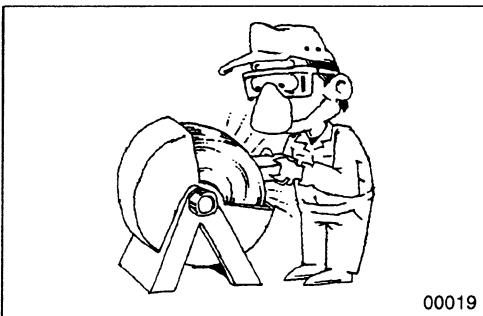

00019

Wear goggles when using a grinder or welder. Pay full attention to safety by wearing gloves when necessary. Watch out for sharp edges, etc. that might injure your hands or fingers.

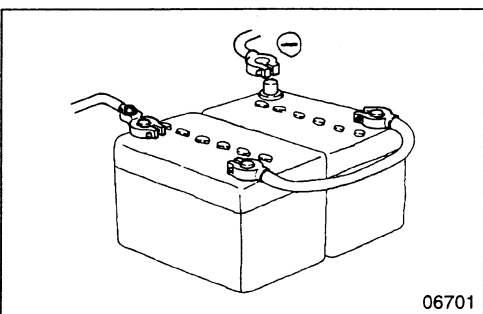

06701

Before carrying out maintenance work on the electric system, disconnect the negative terminals of the batteries.

PRECAUTIONS FOR MAINTENANCE OPERATION

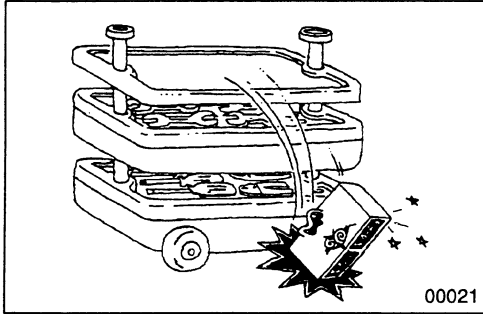

- Take care when handling sensors, relays, etc. which are vulnerable to shock and heat.

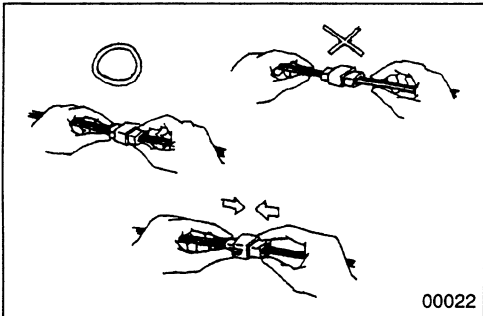

- Pull the connector, and not the harness lead, to separate connectors. To separate a lock-type connector, first push toward arrow mark. To re-connect a lock-type connector, press the separated parts until they click together.

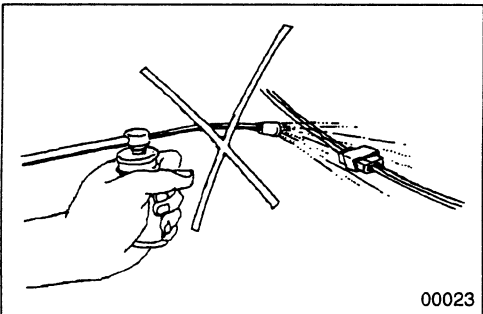

- When washing the vehicle, cover the electric system parts and instruments with waterproof material beforehand (Cover with vinyl sheet or the like). Keep water away from harness wire connectors and sensors. If any of them should get wet, wipe them off immediately.

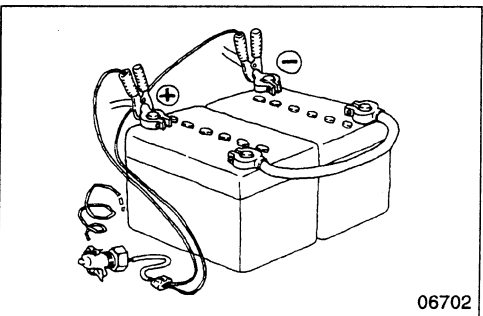

- To apply voltage for testing, check that the positive and negative cables are connected properly, then increase voltage gradually from 0 volt. Do not apply voltage higher than the specified value. In particular, pay close attention to the electronic control unit and sensors, since they are not always supplied with 24V.

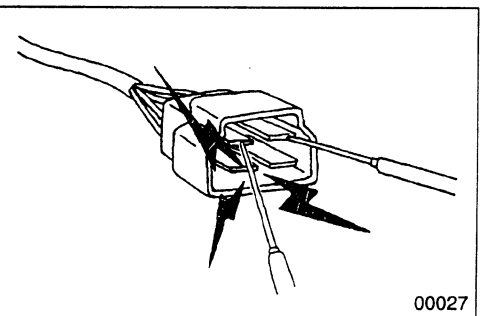

- When using testers or the like for continuity tests, be careful not to allow test probes to touch the wrong terminals.

Measurement Procedures Using Connectors

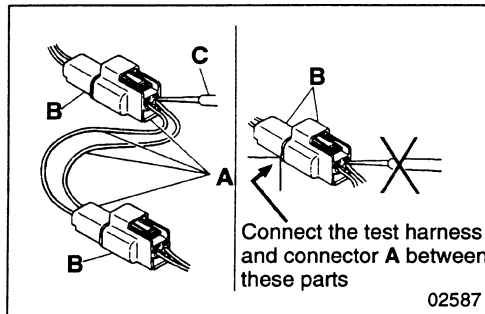

Test with connectors engaged (continuity through circuit obtained) <Waterproof connector>

Prepare a test harness and connectors A, then connect it between the two parts of harness B that is to be tested. Check the circuit by touching test probe C to the test connector.

Never insert the test probe from the harness side of the waterproof connection, or waterproof performance might be diminished causing corrosion of the connector.

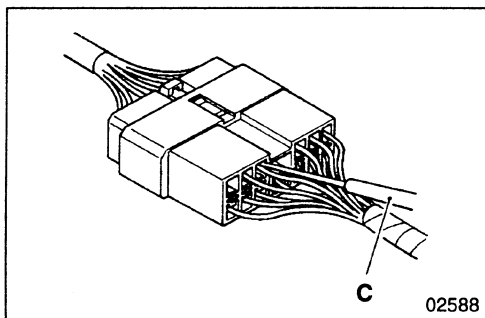

<Non-waterproof connector>

Insert test probe C from the harness side of the connector. Where control units, etc. have connectors that are too small to accept the test probe, do not force the test probe into them.

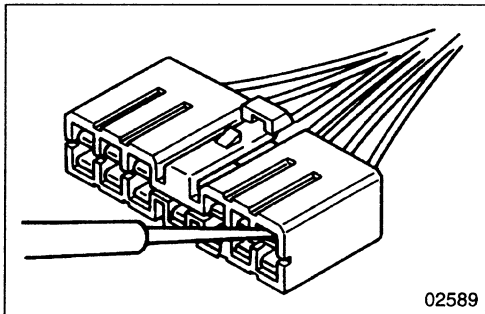

Test with connectors disengaged

Using female pins

Insert a test probe into a terminal. However, do not force the probe into the terminal, or it will cause a poor contact.

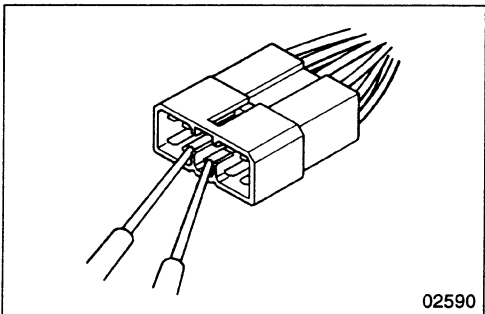

Using male pins

Touch the pins directly using test probes.

CAUTION ⚠

Be sure that you do not short circuit the connector pins when you use the test probe because this could damage the internal circuit of the electronic control unit.



Suggest:

For more complete manuals. Please go to the home page.

<https://www.ebooklibonline.com>

If the above button click is invalid. Please download this document first, and then click the above link to download the complete manual.

Thank you so much for reading

PRECAUTIONS FOR MAINTENANCE OPERATION

Connector Inspection Procedures

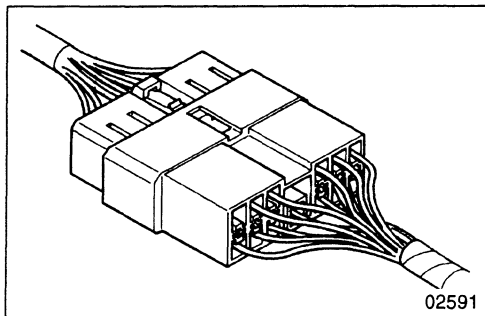

Visual inspection

Check for loose connection and poor engagement.

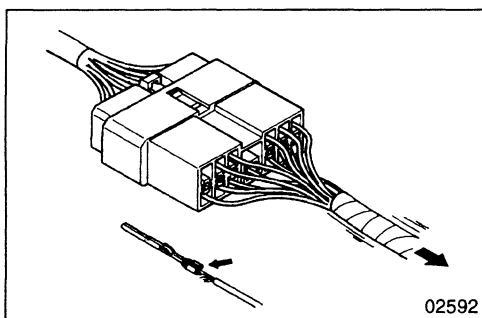

Check if harnesses are broken by pulling gently around the terminals.

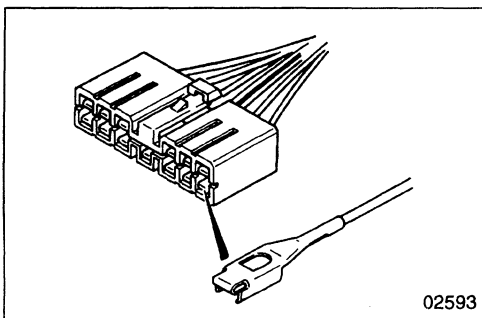

Check for a decrease in contact pressure between the male and female terminals.

Check for poor contact caused by connector pins having fallen out, rusted terminals or foreign particles.

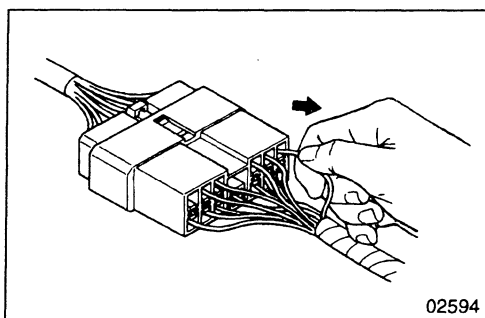

Connector pin fall out inspection

Damaged connector pin stoppers can cause poor engagement of the terminals (male and female pins) even if the connector body is secured, and might cause some pins to fall out. Check if the pins have fallen out from the connector by pulling each harness gently.

Inspection Procedures for Blown Fuses

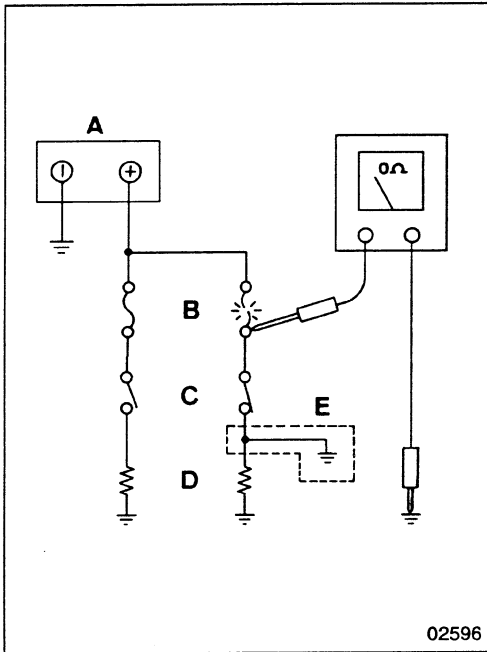

Remove fuse **B** and measure resistance between the loaded side of the fuse and ground.

Turn on all circuit switches (connected to the fuse). If the resistance value reading is approximately 0, a short has occurred between the switch and the loaded point. A value of other than zero may indicate that the fuse was blown by a temporary short but the short is no longer present.

The major causes of a short circuit are as follows:

- Harness stuck onto the vehicle body.
- Harness sheath damaged by friction or heat.
- Water in connectors or circuits.
- Mistakes (accidental short circuits)

- A: Battery
- B: Fuse
- C: Loaded switch
- D: Load
- E: Short circuit

Precautions for Handling Alternator

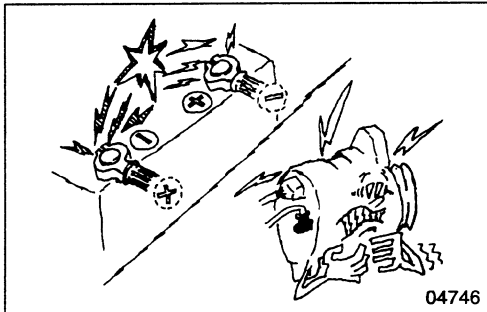

When servicing the alternator, pay attention to the following:

- Do not connect the alternator with battery polarities reversed. If the alternator is connected with reversed polarities, a large current flow from the battery to the alternator occurs, and the diode or regulator might be damaged.

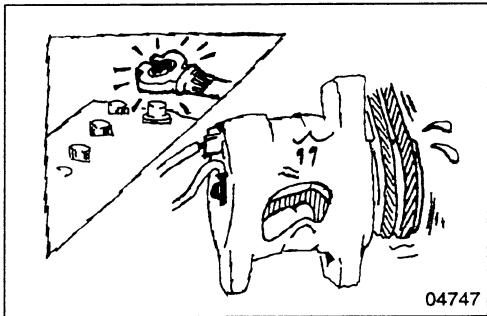

- While the engine is running, do not remove the battery terminals. If the battery terminals are removed at that time, a surge voltage is generated and the diode or regulator might be weakened.

<https://www.ebooklibonline.com>

Hello dear friend!

Thank you very much for reading.

Enter the link into your browser.

The full manual is available for immediate download.

<https://www.ebooklibonline.com>