

WA500-1L S/N A20854-UP
WA500-1L Table of Contents

DESCRIPTION

ENGINE - S6D140-1
ENGINE RELATED PARTS & ELECTRICAL SYSTEM
TORQUE CONVERTER AND TRANSMISSION
DRIVE SHAFT, AXLES WHEELS & BRAKE SYSTEMS
STEERING CONTROL SYSTEM
FRAME, GUARD & SUPERSTRUCTURE
WORK EQUIPMENT CONTROL SYSTEM
WORK EQUIPMENT
MARK PLATES, TOOLS & KITS

WA500-1L S/N A20854-UP
ENGINE RELATED PARTS & ELECTRICAL SYSTEM

DESCRIPTION

ENGINE MOUNTING
ENGINE OIL DRAIN AND AIR CLEANER SERVICE INDICATOR
ACCELERATOR LINKAGE
ACCELERATOR PEDAL
RADIATOR ASSEMBLY
RADIATOR MOUNTING AND ENGINE FAN GUARD
RADIATOR DUST AND DIRT PROTECTOR
RADIATOR PIPING
FUEL TANK AND PIPING
WATER SEPARATOR PIPING
ADDITIONAL FUEL FILTER PIPING
WATER SEPARATOR AND ADDITIONAL FUEL FILTER PIPING
BATTERY AND BATTERY RELAY
ELECTRICAL SYSTEM INSTRUMENT PANEL
ELECTRICAL SYSTEM CONSOLE BOX, L.H. (WITH CAB)
ELECTRICAL SYSTEM CONSOLE BOX, R.H.
ELECTRICAL SYSTEM FRONT LAMP MOUNTING
FRONT DRIVING LIGHT
L.H. TURN SIGNAL AND PARKING LIGHT
R.H. TURN SIGNAL AND PARKING LIGHT
ELECTRICAL SYSTEM FRONT FRAME LINE
ELECTRICAL SYSTEM FLOOR LINE
ELECTRICAL SYSTEM ELECTRONICALLY CONTROLLED SUSPENSION SYSTEM
ELECTRICAL SYSTEM REAR FRAME LINE
ELECTRICAL SYSTEM ENGINE SENSOR LINE
ELECTRICAL SYSTEM BATTERY LINE
ELECTRICAL SYSTEM REAR WORK LIGHT LINE
L.H. REAR COMBINATION LIGHT
R.H. REAR COMBINATION LIGHT
REAR WORK LIGHT
ELECTRICAL SYSTEM LICENSE LAMP AND BRACKET
MONITOR PANEL FOR MACHINES WITHOUT GROUND DRIVEN STEERING
MONITOR PANEL FOR MACHINES WITH GROUND DRIVEN STEERING

<https://www.ebooklibonline.com>

Hello dear friend!

Thank you very much for reading.

Enter the link into your browser.

The full manual is available for immediate download.

<https://www.ebooklibonline.com>

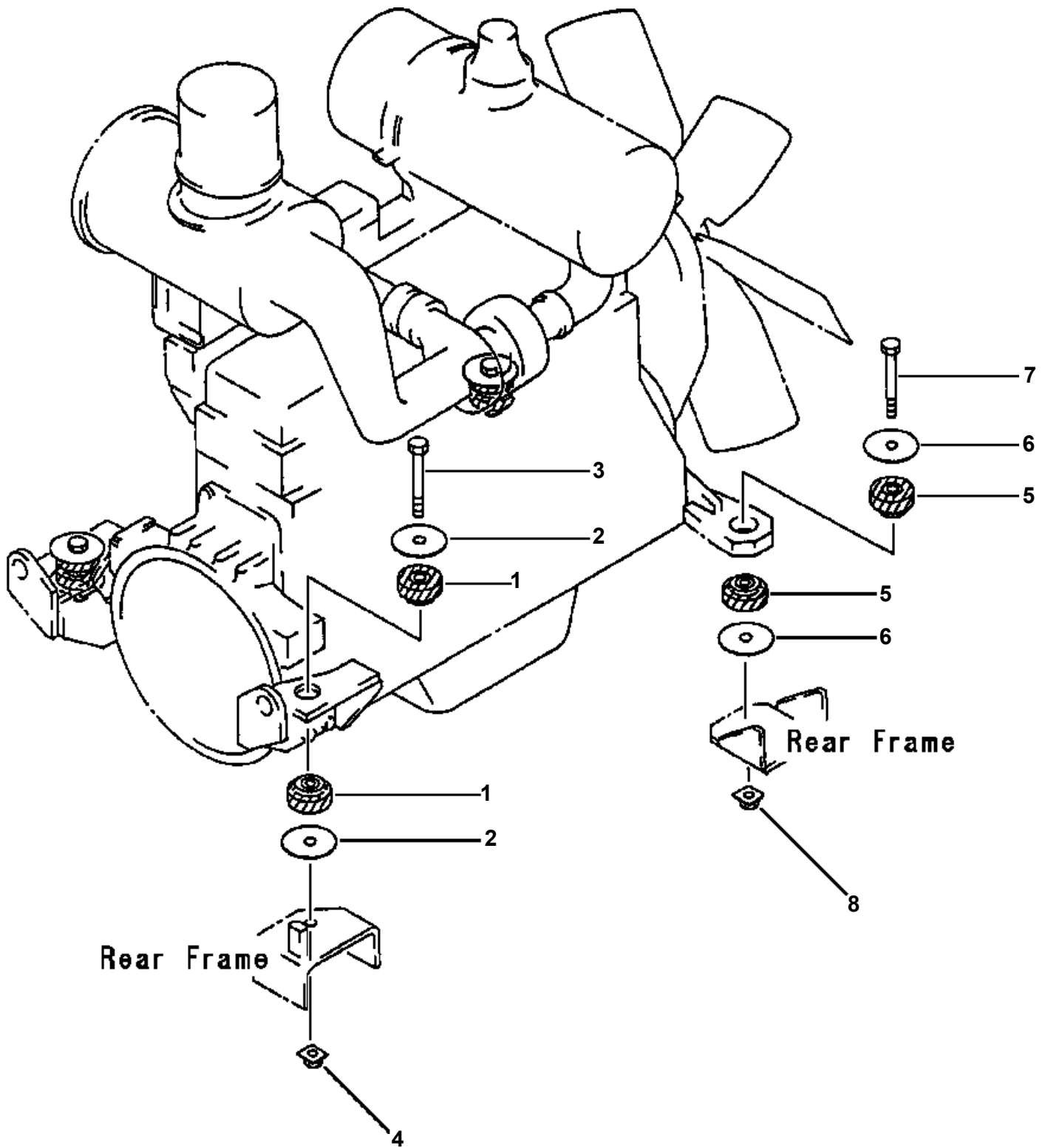

WA500-1L S/N A20854-UP
ENGINE MOUNTING

ITEM NO.	PART NO.	DESCRIPTION	Q'TY
1	425-01-11370	CUSHION, REAR ENGINE MOUNT	4
2	425-01-11220	WASHER	4
3	01011-32225	BOLT	2
4	425-01-11250	PLATE	2
5	425-01-11350	CUSHION, FRONT ENGINE MOUNT	4
6	425-01-11220	WASHER	4
7	01011-32225	BOLT	2
8	425-01-11250	PLATE	2

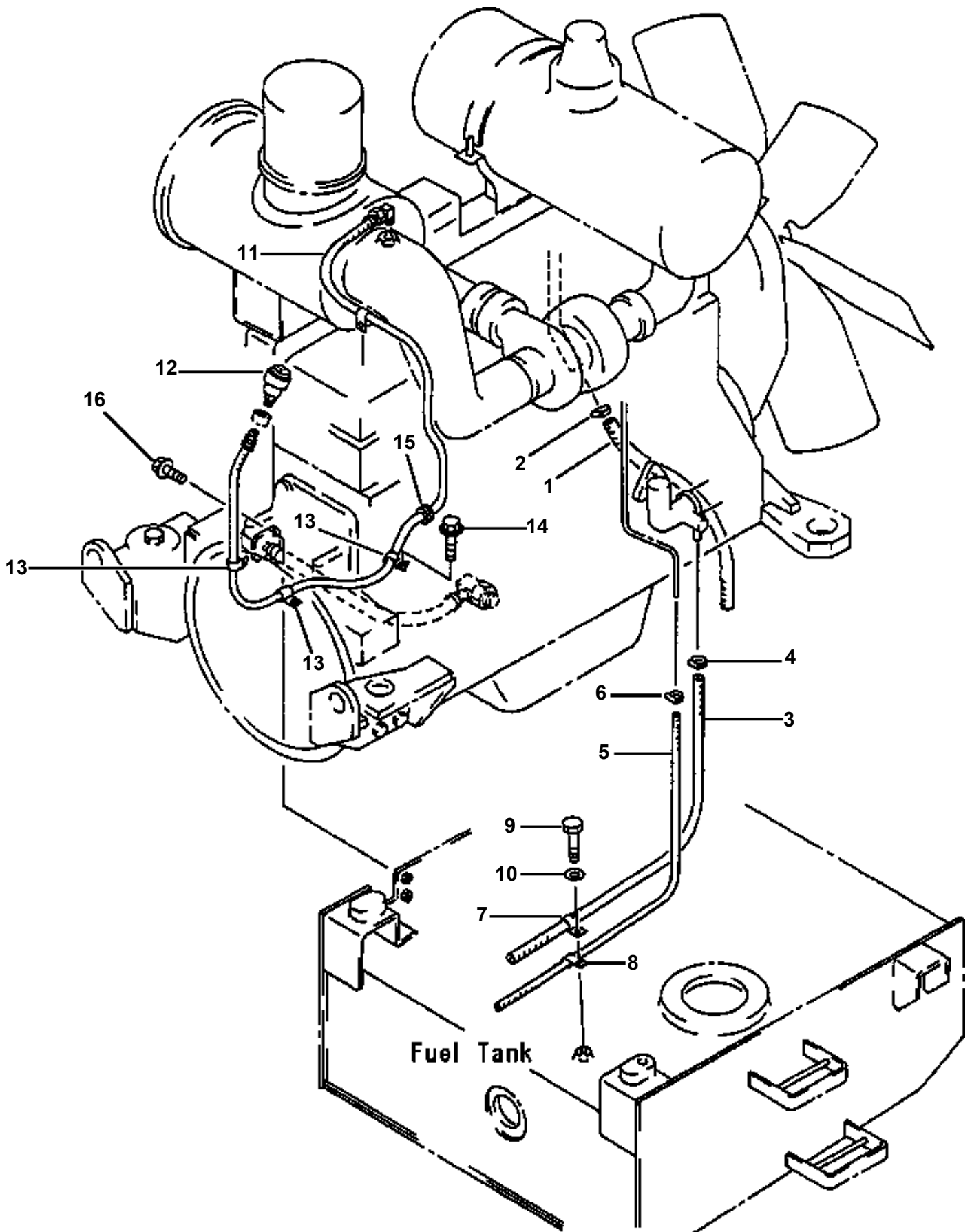

WA500-1L S/N A20854-UP
ENGINE OIL DRAIN AND AIR CLEANER SERVICE INDICATOR

ITEM NO.	PART NO.	DESCRIPTION	Q'TY
1	07260-22080	HOSE	1
2	07280-03423	CLAMP	1
3	07260-21480	HOSE	1
4	07280-02523	CLAMP	1
5	07270-01070	TUBE	1
6	07280-01620	CLAMP	1
7	08036-02514	CLIP	1
8	08036-01414	CLIP	1
9	01010-51020	BOLT	1
10	01643-31032	WASHER	1
11	08671-50160	HOSE	1
12	08670-02001	INDICATOR, AIR CLEANER SERVICE	1
13	04434-51410	CLIP	4
14	01435-01016	BOLT	4
15	08037-01610	GROMMET	1
16	01435-01025	BOLT	2
N/I	08034-20536	STRAP, TIE	1

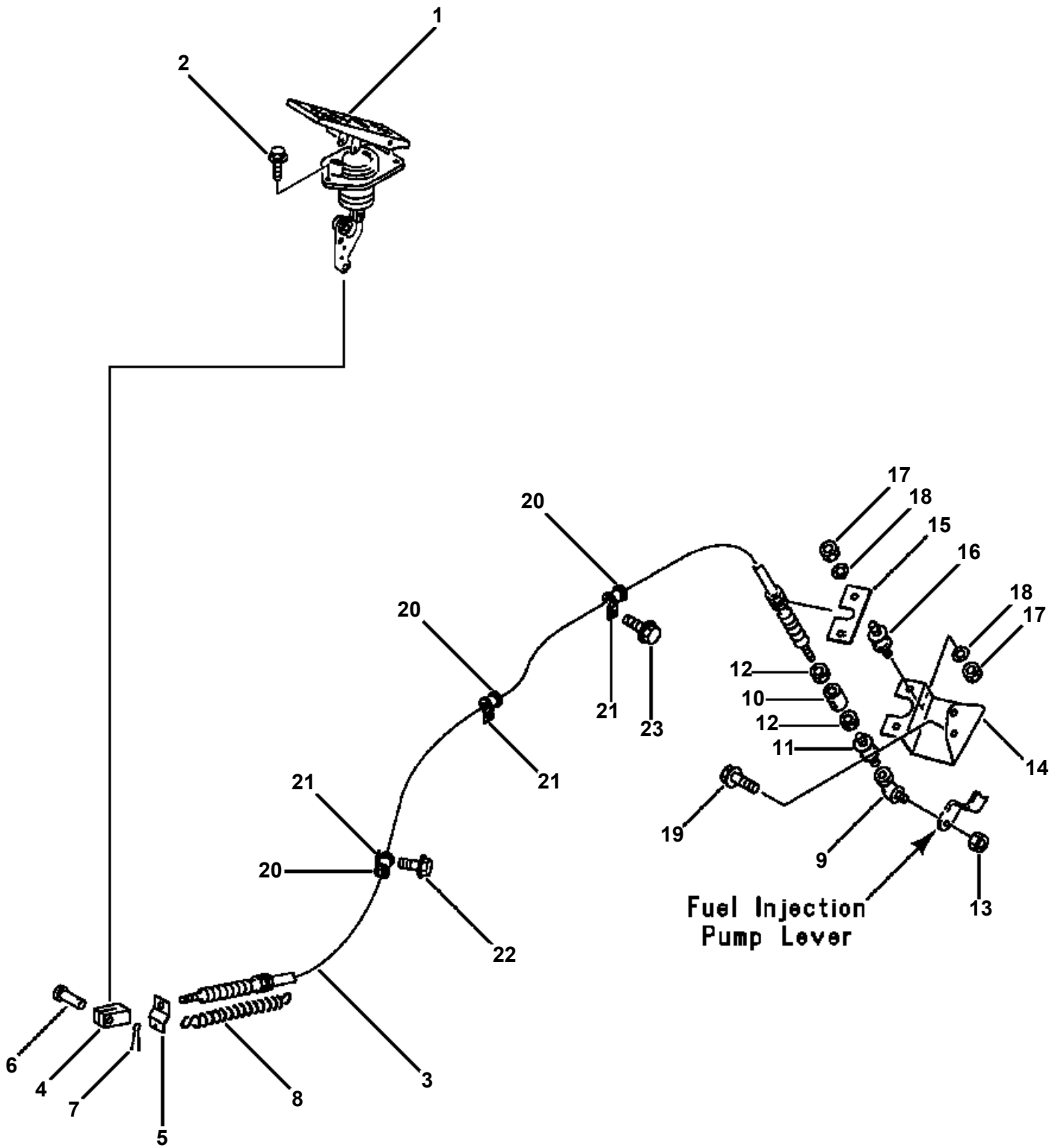

**WA500-1L S/N A20854-UP
ACCELERATOR LINKAGE**

ITEM NO.	PART NO.	DESCRIPTION	Q'TY
1		PEDAL ASSEMBLY (SEE PG 01-008)	
2	01435-00620	BOLT, MOUNT PEDAL	3
3	23S-43-28140	CABLE, ACCELERATOR	1
4	04210-20624	YOKE	1
5	425-43-11420	PLATE	1
6	04205-10620	PIN	1
7	04050-01612	PIN, COTTER	1
8	415-43-11241	SPRING	1
9	424-09-12450	JOINT	1
10	421-43-11330	ROD	1
11	424-43-11240	CUSHION	1
12	01580-10605	NUT	2
13	426-09-11130	NUT	1
14	425-43-11242	BRACKET	1
15	425-43-11250	PLATE	1
16	424-43-11240	CUSHION	2
17	01580-10605	NUT	4
18	424-43-11250	WASHER	4
19	01435-01020	BOLT, MOUNT BRACKET	2
20	425-43-11180	GROMMET	3
21	08036-02514	CLIP	3
22	01435-01220	BOLT	1
23	01435-01016	BOLT	2

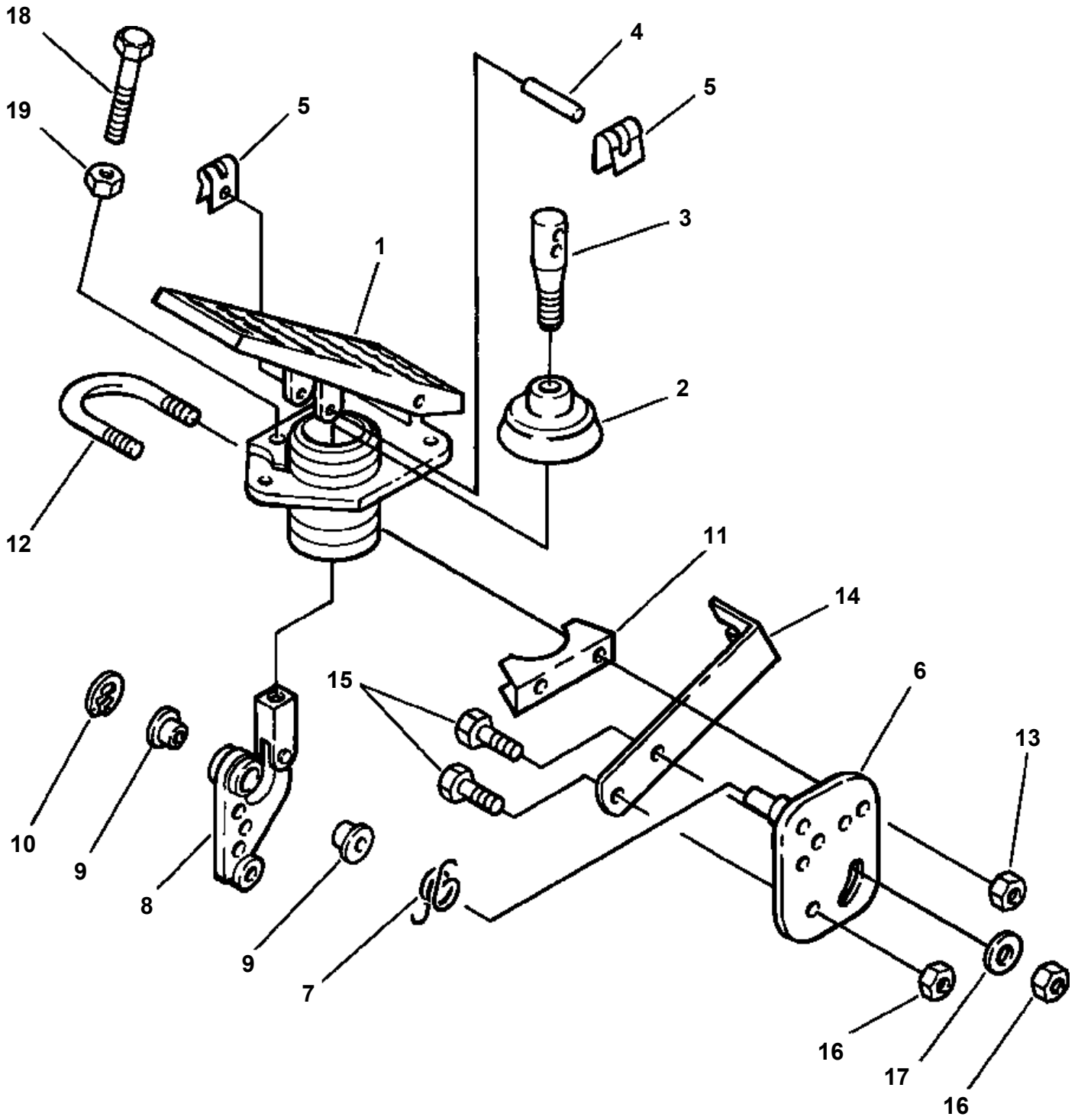

**WA500-1L S/N A20854-UP
ACCELERATOR PEDAL**

ITEM NO.	PART NO.	DESCRIPTION	Q'TY
	421-43-11310	PEDAL ASSEMBLY, ACCELERATOR	1
1	417-43-11210	· PEDAL ASSEMBLY	1
2	417-43-11360	· BOOT	1
3	417-43-11310	· ROD	1
4	417-43-11320	· PIN	1
5	417-43-11330	· CLIP	2
6	417-43-11220	· PLATE	1
7	417-43-11240	· SPRING	1
8	417-43-11230	· LEVER	1
9	417-43-11250	· BEARING	2
10	417-43-11260	· CLIP	1
11	417-43-11290	· SUPPORT	1
12	417-43-11270	· U-BOLT	1
13	417-43-11280	· NUT	2
14	421-43-11320	· SUPPORT	1
15	01010-50616	· BOLT	2
16	417-43-11350	· NUT	2
17	01643-30623	· WASHER	1
18	01010-50860	· BOLT	1
19	01580-10806	· NUT	1

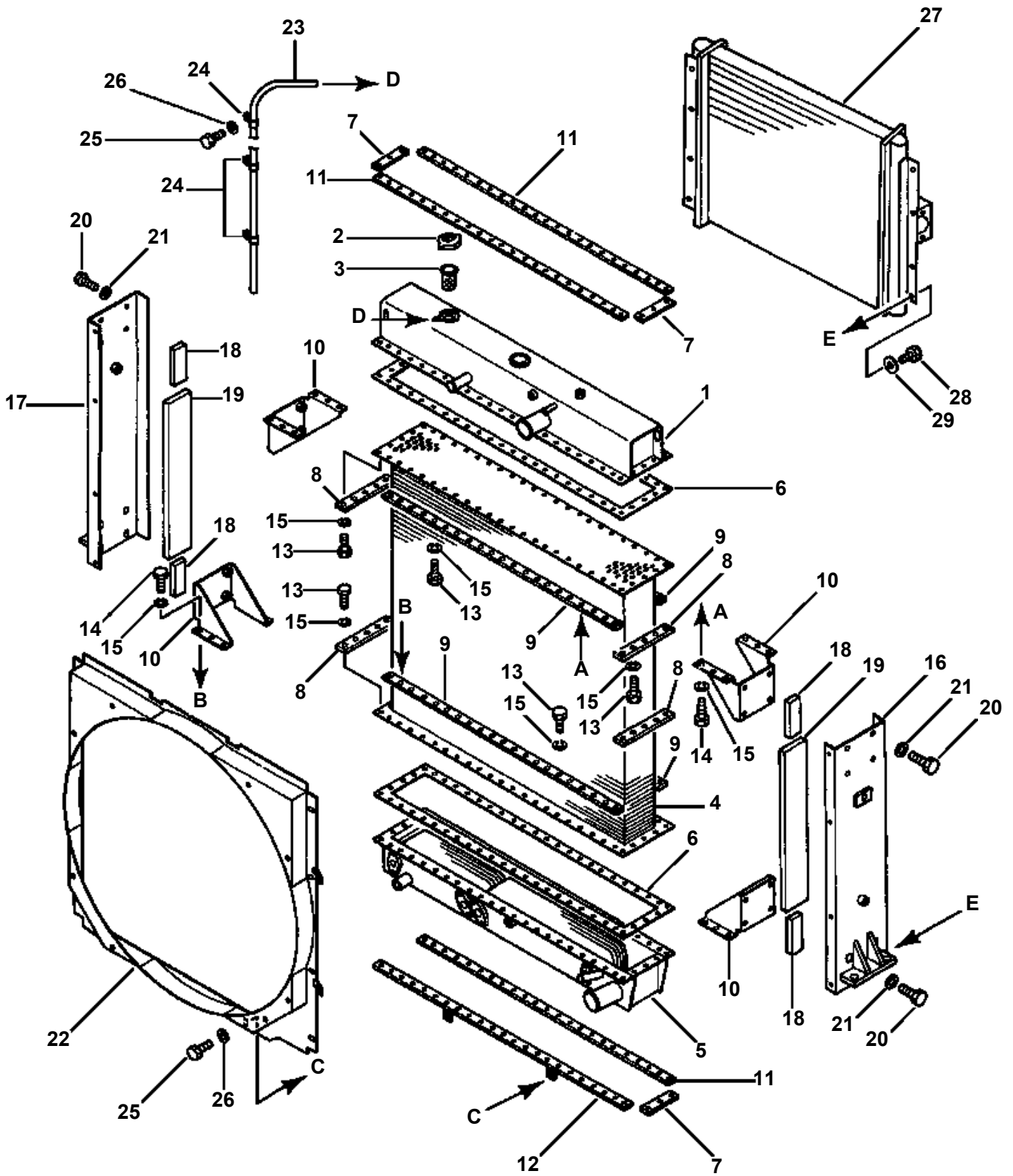

**WA500-1L S/N A20854-UP
RADIATOR ASSEMBLY**

ITEM NO.	PART NO.	DESCRIPTION	Q'TY
	425-03-11302	RADIATOR	1
1	425-03-11122	· TANK, UPPER	1
2	421-03-11460	· CAP, RADIATOR	1
3	101-03-13160	· STRAINER	1
4	425-03-11111	· CORE	1
5	425-03-11134	· TANK, LOWER (WITH OIL COOLER)	1
6	425-03-11191	· GASKET	2
7	421-03-11260	· PLATE	3
8	425-03-11181	· PLATE	4
9	425-03-11171	· PLATE	4
10	425-03-11161	· BRACKET	4
11	425-03-11340	· PLATE	3
12	425-03-11290	· PLATE	1
13	01010-51030	· BOLT	80
14	01010-51035	· BOLT	24
15	01602-21030	· WASHER, LOCK	104
16	425-03-11141	· SUPPORT, LH	1
17	425-03-11151	· SUPPORT, RH	1
18	425-03-11350	· PACKING	4
19	425-03-11360	· PACKING	2
20	01010-51225	· BOLT	16
21	01643-31232	· WASHER	16
22	425-03-11280	· SHROUD	1
23	425-03-11370	· HOSE, OVERFLOW	1
24	232-03-11210	· CLIP	3
25	01010-51025	· BOLT	10
26	01643-31032	· WASHER	10
27	425-03-11410	· COOLER, OIL	1
28	01010-51020	· BOLT	8
29	01643-31032	· WASHER	8

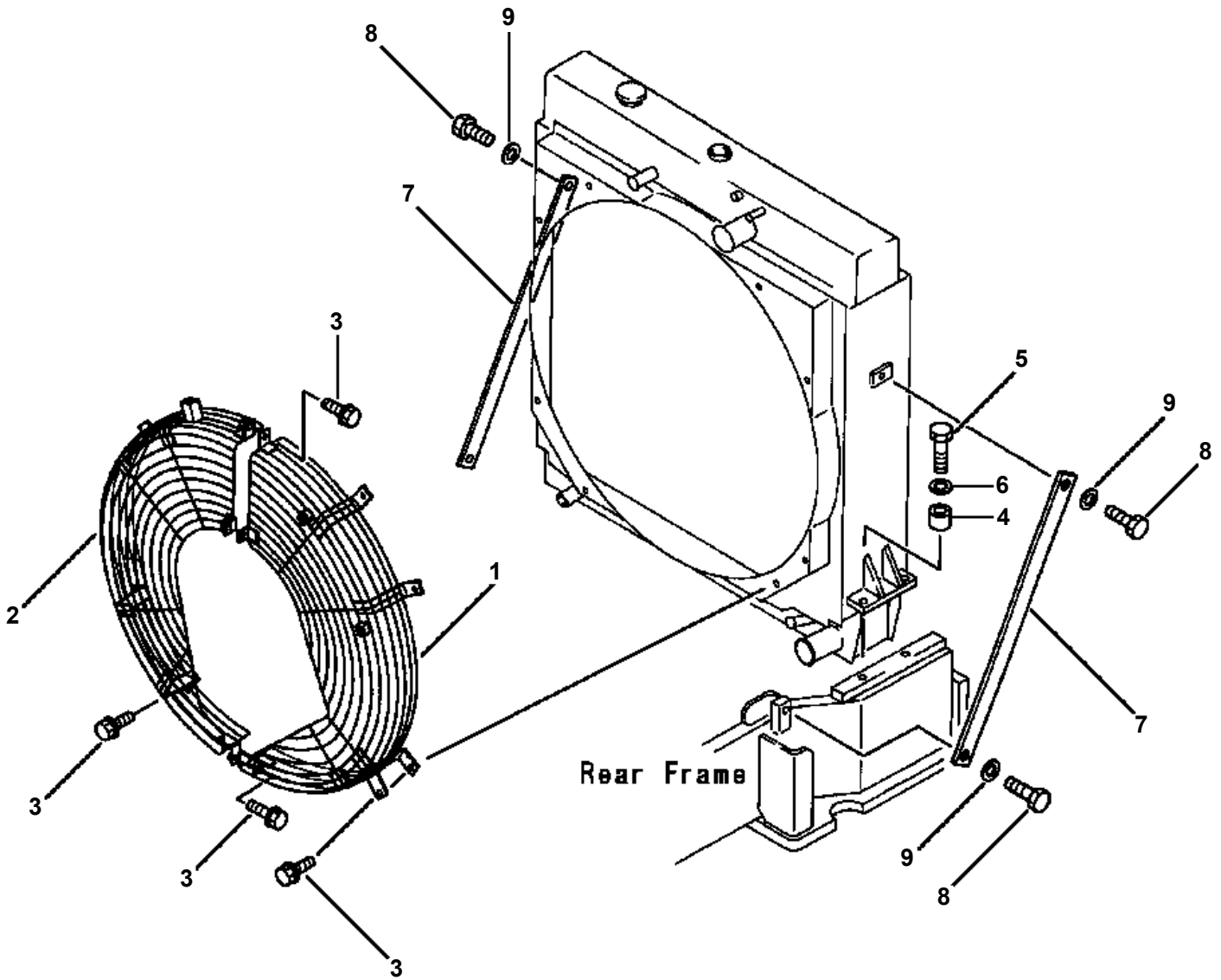

WA500-1L S/N A20854-UP
RADIATOR MOUNTING AND ENGINE FAN GUARD

ITEM NO.	PART NO.	DESCRIPTION	Q'TY	REF
1	425-03-11313	GUARD, ENGINE FAN - LH	1	
2	425-03-11323	GUARD, ENGINE FAN - RH	1	F1
	425-963-1350	GUARD, ENGINE FAN - RH	1	F2
3	01435-01020	BOLT	11	
4	425-03-12170	SPACER	4	
5	01010-32070	BOLT	4	
6	01643-32060	WASHER	4	
7	425-03-11331	PLATE	2	
8	01010-32055	BOLT	4	
9	01643-32060	WASHER	4	
		F1 - USED ON MACHINES WITHOUT AIR CONDITIONER. F2 - USED ON MACHINES WITH AIR CONDITIONER.		

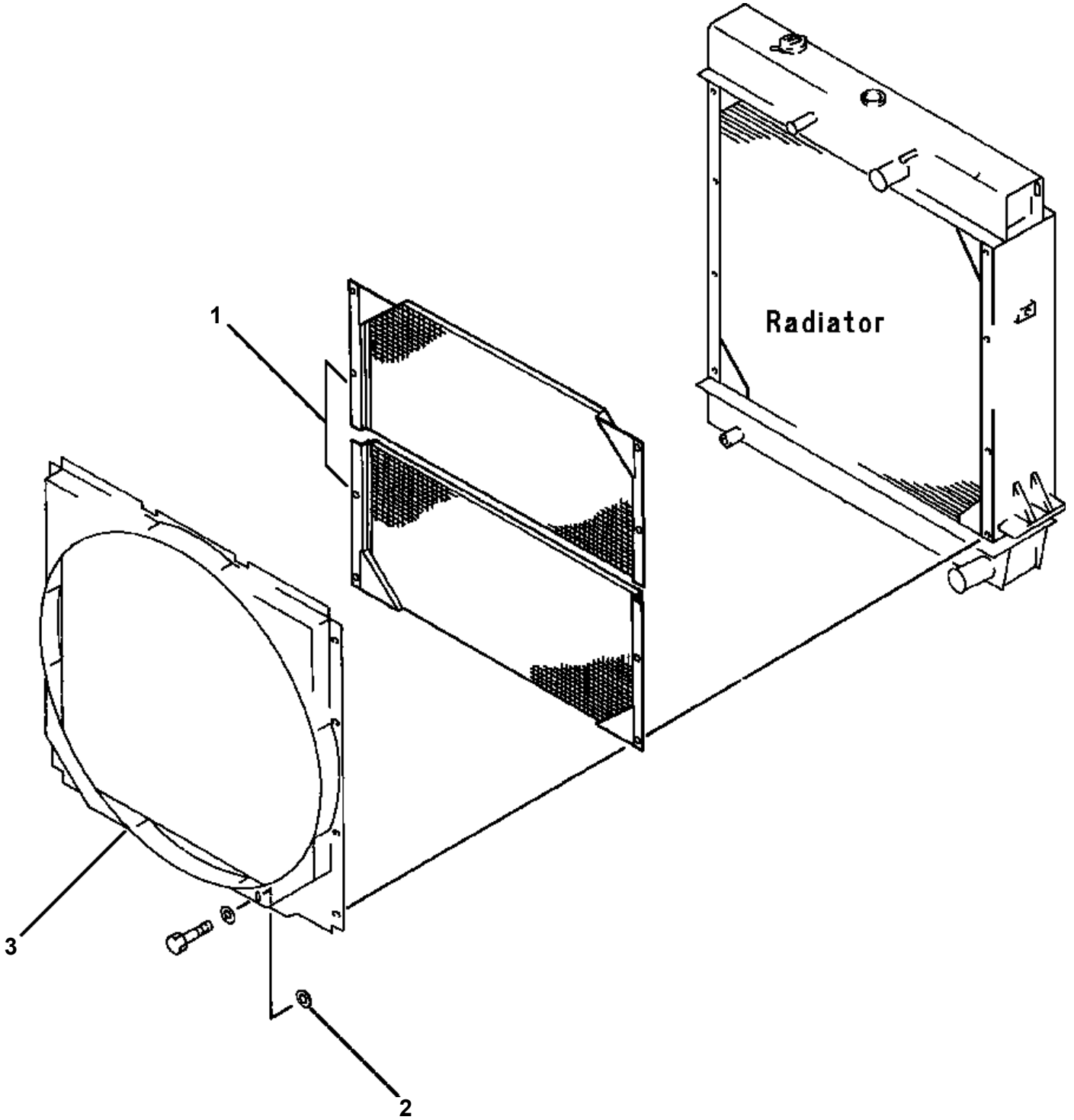

WA500-1L S/N A20854-UP
RADIATOR DUST AND DIRT PROTECTOR

ITEM NO.	PART NO.	DESCRIPTION	Q'TY
1	425-977-1110	PROTECTOR, RADIATOR DUST AND DIRT	2
2	01643-31232	WASHER	2
3		SHROUD, RADIATOR (SEE PG 01-010)	

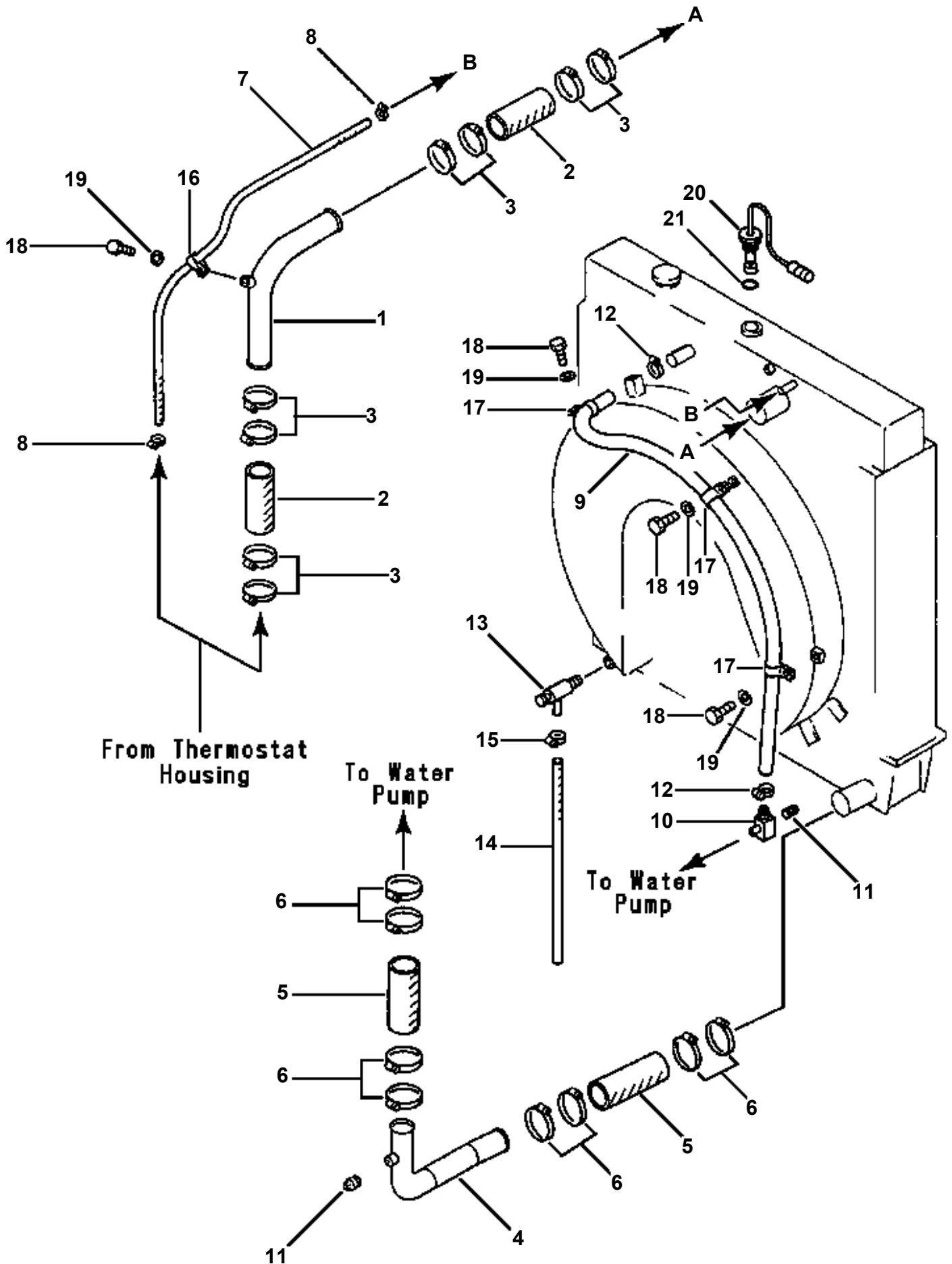

**WA500-1L S/N A20854-UP
RADIATOR PIPING**

ITEM NO.	PART NO.	DESCRIPTION	Q'TY
1	425-03-12111	TUBE	1
2	425-03-12120	HOSE	2
3	07281-00809	CLAMP	8
4	425-03-12162	TUBE	1
5	425-03-12180	HOSE	2
6	07281-01029	CLAMP	8
7	09483-00308	HOSE	1
8	07281-00197	CLAMP	2
9	09483-06180	HOSE	1
10	425-03-12152	ELBOW	1
11	425-03-12240	PLUG	2
12	07281-00419	CLAMP	2
13	07730-50004	VALVE, RADIATOR DRAIN	1
14	07260-21445	HOSE, DRAIN	1
15	07281-00259	CLAMP	1
16	424-06-12740	CLIP	1
17	113-899-7950	CLIP	3
18	01010-51020	BOLT	4
19	01643-31032	WASHER	4
20	7861-91-4540	SENSOR, RADIATOR WATER LEVEL	1
21	07002-23634	O-RING, SENSOR	1

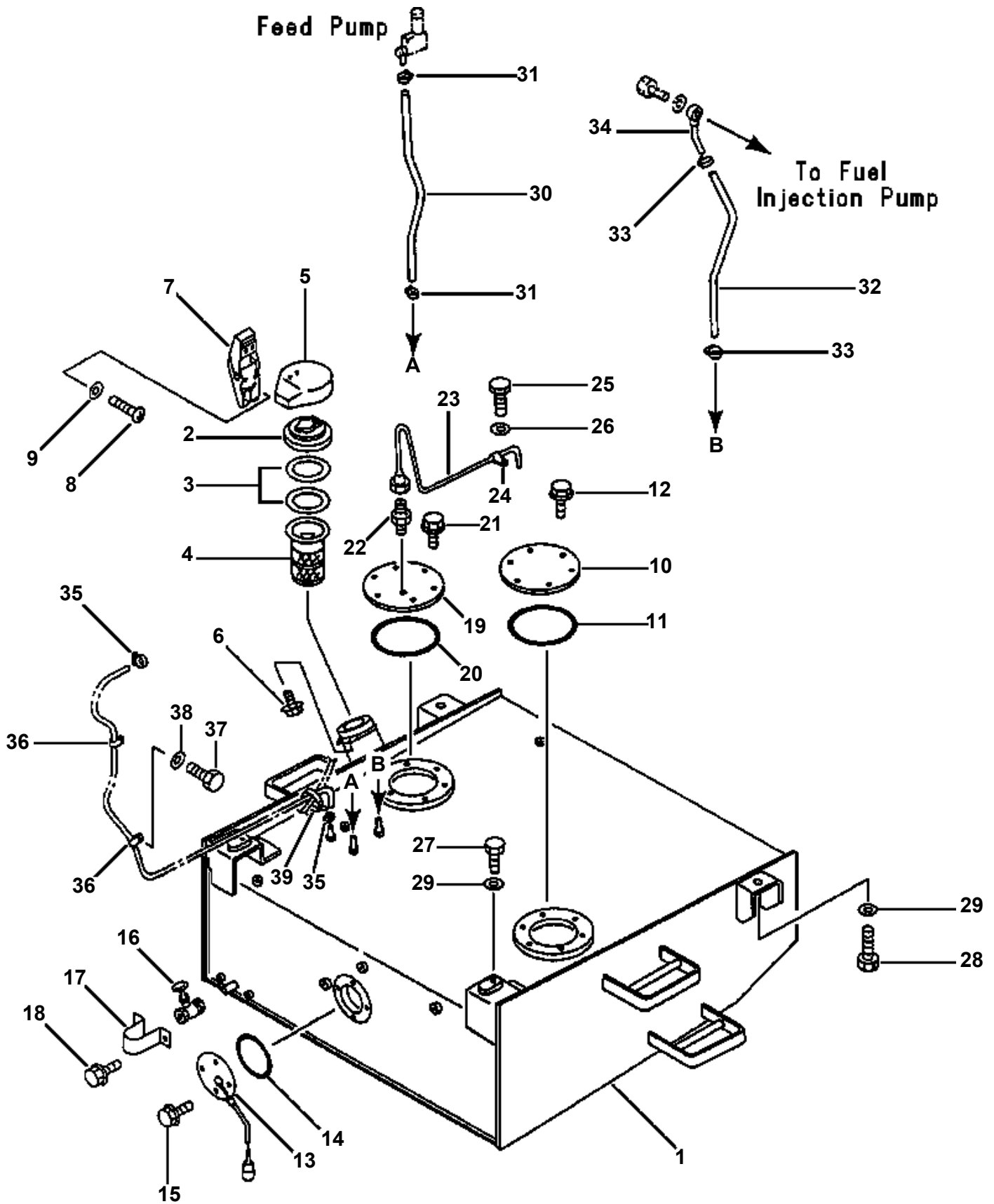



Suggest:

For more complete manuals. Please go to the home page.

<https://www.ebooklibonline.com>

If the above button click is invalid. Please download this document first, and then click the above link to download the complete manual.

Thank you so much for reading

**WA500-1L S/N A20854-UP
FUEL TANK AND PIPING**

ITEM NO.	PART NO.	DESCRIPTION	Q'TY
1	425-04-11113	TANK, FUEL	1
2	423-04-11362	CAP, FUEL TANK	1
3	417-04-21230	· PACKING	1
4	07056-18416	STRAINER, FUEL TANK	1
5	425-04-11161	COVER, FUEL CAP	1
6	01435-01020	BOLT, CAP COVER	2
7	421-09-12321	HOLDER	1
8	01220-40508	SCREW, HOLDER	2
	01220-40512	SCREW, HOLDER	3
9	01641-20405	WASHER	5
10	428-04-11120	COVER	1
11	07000-05200	O-RING, COVER	1
12	01435-01025	BOLT, MOUNT COVER	6
13	7861-91-4820	SENSOR, FUEL LEVEL	1
14	07000-02085	O-RING, SENSOR	1
15	01435-01014	BOLT, MOUNT SENSOR	4
16	416-04-10130	VALVE, FUEL TANK DRAIN	1
17	419-04-11120	GUARD	1
18	01435-00816	BOLT, MOUNT GUARD	2
19	421-04-11182	COVER	1
20	07000-05200	O-RING, COVER	1
21	01435-01025	BOLT, MOUNT COVER	6
22	423-09-12120	CONNECTOR, VENT TUBE	1
23	425-04-11142	TUBE, VENT	1
24	424-04-11120	CLIP	1
25	01010-51020	BOLT	1
26	01643-31032	WASHER	1
27	01011-32405	BOLT, MOUNT FUEL TANK - FRONT	2
28	01010-32470	BOLT, MOUNT FUEL TANK - REAR	2
29	01643-32460	WASHER	4
30	07270-21055	TUBE	1
31	07281-00197	CLAMP	2
32	07270-21065	TUBE	1
33	07281-00197	CLAMP	2
34	424-04-11130	TUBE	1
35	07280-00910	CLAMP	2
36	08036-10814	CLIP	2
37	01010-31016	BOLT	1
38	01643-31032	WASHER	1
39	08034-00519	BAND	1

FIG 01-022

WATER SEPARATOR PIPING

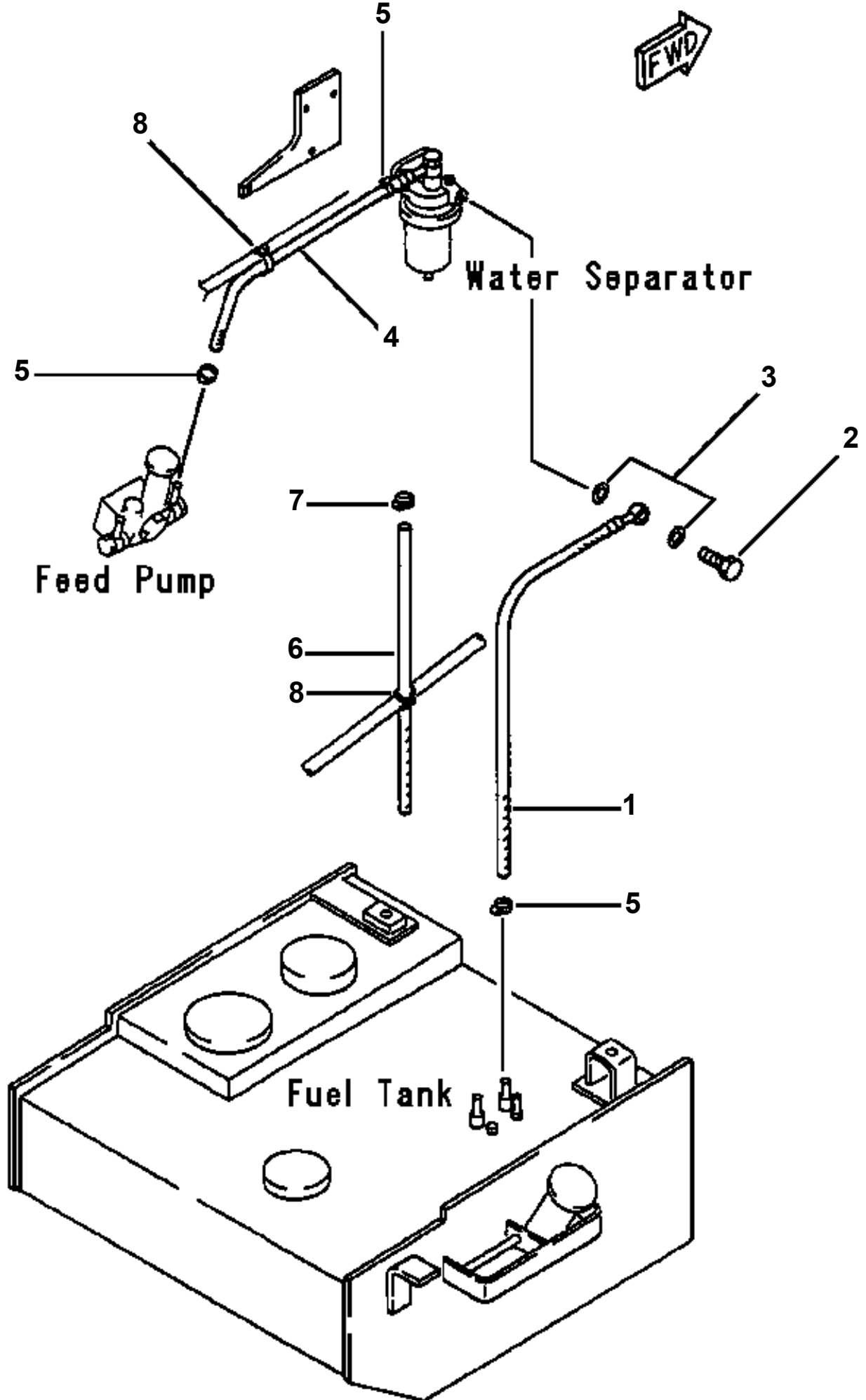

<https://www.ebooklibonline.com>

Hello dear friend!

Thank you very much for reading.

Enter the link into your browser.

The full manual is available for immediate download.

<https://www.ebooklibonline.com>