

**KOBELCO**

# **SERVICEMAN'S HANDBOOK**

## **HYDRAULIC EXCAVATOR GRAND BEETLE**

### **SR Series**

**SK70SR**

**SK115SR**

**SK115SRDZ (KAI)**

**SK135SR**

**SK135SRLC**

**SK135SRLC (KAI)**

**SK235SR**

Applicable: SK70SR YT00101~, SK115SR YV00101~, SK115SRDZ(KAI) YY00101~

Applicable: SK135SR YY00101~, SK135SRLC YH00101~, SK135SRLC(KAI) YH00101~, SK235SR YF00101~

Book code No.

S7YO00100ZE01

**KOBELCO**

**Hydraulic Excavator**

*Grand* **Beetle**

**SR SERIES**

**SERVICEMAN HANDBOOK**

<b>SK70SR</b>	YT00101~
<b>SK115SR</b>	YV00101~
<b>SK135SR</b>	YY00101~
<b>SK115SRDZ(KAI)</b>	YY00101~
<b>SK135SRLC</b>	YH00101~
<b>SK135SRLC(KAI)</b>	YH00101~
<b>SK235SR</b>	YF00101~

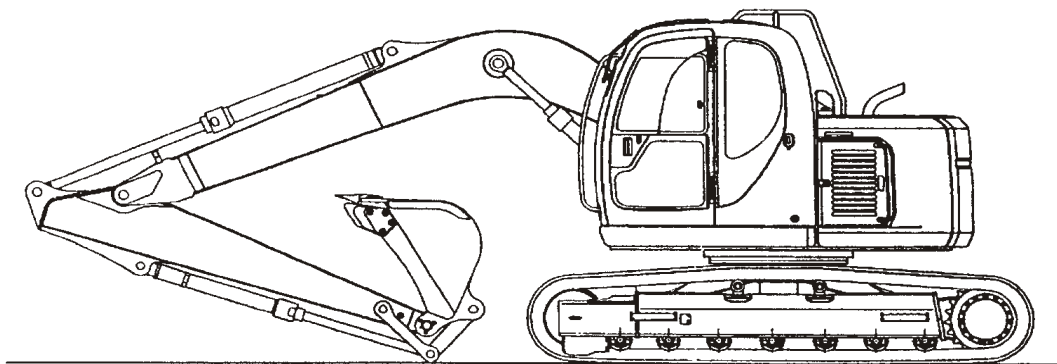

 **KOBE STEEL, LTD.**

## CONTENTS

1. GENERAL DIMENSIONS .....	1
2. MACHINE SPECIFICATION TABLE .....	3
3. MAJOR SPECIFICATIONS .....	7
3-1 ENGINE SPECIFICATIONS .....	7
3-2 HYDRAULIC COMPONENTS SPECIFICATIONS & PERFORMANCE .....	21
3-3 HYDRAULIC CYLINDER LIST .....	23
4. PERFORMANCE TABLE .....	25
5. WEIGHT OF COMPONENTS .....	26
6. CAPACITY TABLE OF LUBRICATION OIL AND COOLANT .....	31
7. LIST OF FILTER AND ELEMENT .....	31
8. SPECIFIED OIL AND GREASE AND FILTER ELEMENT LIST .....	32
9. PERFORMANCE INSPECTION STANDARD .....	49
10. HYDRAULIC OIL PUMP CONTROL CURVE .....	53
11. MEASUREMENT OF HYDRAULIC PRESSURE .....	59
12. MEASUREMENT OF ENGINE SPEED .....	62
13. PRESSURE ADJUSTMENT POSITION .....	65
14. PROCEDURE FOR ADJUSTING RELIEF VALVE .....	69
15. GAUGE CLUSTER AND SWITCH PANEL .....	72
16. TROUBLESHOOTING SUMMARIZED MECHATRO CONTROL .....	77
16-1 TROUBLE SHOOTING SUMMARIZED .....	77
16-2 SERVICE DIAGNOSTICS .....	80
16-3 ERROR DIAGNOSTICS .....	85
16-4 CONTENTS OF THE TROUBLE HISTORY .....	87
16-5 MULTI DISPLAY SELF DIAGNOSIS .....	88
16-6 PRIORITY OF MULTI DISPLAY WARNING DISPLAY AND SELF DIAGNOSIS DISPLAY .....	93

**<https://www.ebooklibonline.com>**

Hello dear friend!

Thank you very much for reading.

Enter the link into your browser.

The full manual is available for immediate download.

**<https://www.ebooklibonline.com>**

16-7	HOW TO CORRECT THE E/G OIL SUPPLY CUMULATIVE TIME .....	95
16-8	ADJUSTMENT OF MECHATRO CONTROLLER .....	96
16-9	ACCEPTANCE CRITERION FOR ELECTRICAL FITTING IN CONTROL SYSTEM .....	102
16-10	OUTLINE OF MECHATRO SYSTEM .....	104
17.	HYDRAULIC SYSTEM DIAGRAM .....	108
18.	ELECTRIC CIRCUIT DIAGRAM .....	142
19.	DIMENSIONS OF ATTACHMENTS .....	171
20.	MAINTENANCE STANDARD .....	189
20-1	PIN AND BUSHING TABLE OF ATTACHMENT (CLEARANCE BETWEEN PIN AND BUSHING) .....	189
20-2	PIN AND BUSHING TABLE OF ATTACHMENT (LOCATION OF PIN AND BUSHING) .....	203
20-3	RESINOID SHIM CODE .....	207
20-4	UNDER CARRIAGE .....	208
	● MAINTENANCE STANDARD OF TRACK LINK .....	208
	● MAINTENANCE STANDARD OF IDLER .....	209
	● MAINTENANCE STANDARD OF SPROCKET .....	210
	● MAINTENANCE STANDARD OF LOWER ROLLER .....	211
	● MAINTENANCE STANDARD OF UPPER ROLLER .....	212
	● MAINTENANCE STANDARD OF TRACK SPRING .....	213
21.	WORKING RANGES .....	214
22.	LIFTING DIAGRAM .....	226
23.	OPTIONAL PARTS AND DIMENSIONS OF ATTACHMENTS .....	256
23-1	OPTIONAL PARTS ATTACH THE OPTIONAL PARTS TO THE TIP OF THE STOP VALVE ...	256
23-2	ARM SECTION • CYLINDER • BUCKET LINK INSTALLING SECTIONS IN DIMENSIONAL DRAWING .....	257
23-3	DRAWING OF BOSS SECTION .....	258
24.	SUMMARY FOR NIBBLER & BREAKERS .....	259
24-1	LAYING OF EQUIPMETS .....	260

24-2	REFERENCE (BREAKER MANUFACTURER) .....	261
24-3	REMINDERS ON THE USE OF NIBBLER & BREAKERS ...	262
24-4	PRECAUTIONS TO BE EXERCISED ON BREAKERS OF DIFFERENT MANUFACTURES ...	263
25.	REFERENTIAL DATUM .....	267
25-1	TIGHTENING TORQUES FOR NUTS AND SLEEVES .....	267
25-2	PIPE JOINT TIGHTENING TORQUE .....	268
25-3	SI UNIT .....	271
25-4	CONVERSION TABLES .....	272
25-5	PRESSURE CONVERSION TABLE .....	274
25-6	TEMPERATURE CONVERSION TABLE .....	275
25-7	TEMPERATURE CONVERSION DIAGRAM .....	276
25-8	WEIGHT CONVERSION TABLE .....	277
25-9	INCLINE CONVERSION TABLE .....	278
25-10	MATERIAL WEIGHT TABLE .....	279
25-11	LEVER (CONTROL) PATTERN LIST .....	280
25-12	SPECIAL SPANNER FOR TUBE .....	281
25-13	TIGHTENING TORQUES FOR CAPSCREWS AND NUTS ...	282

# SK70SR SK135SR(LC) SK115SR SK235SR

## 1. GENERAL DIMENSIONS

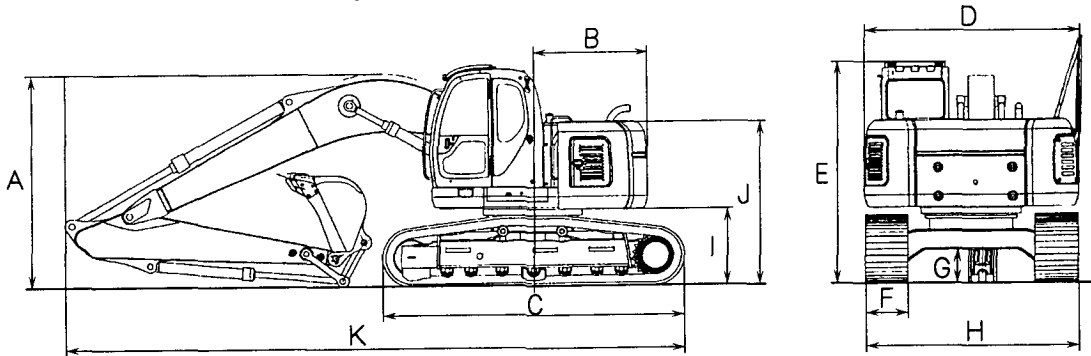

Model	Outside Dimension											
	Arm length	A	B	C	D	E	F	G	H	I	J	K
SK70SR	2,070 (6'9") (STD)	2,600 (8'6")	R1,160 (3'10")	2,860 (9'5")	2,170 (7'2")	2,600 (8'6")	600 (24")	400 (1'4")	2,470 (8'1")	750 (2'6")	1,780 (5'10")	5,790 (19")
	1,650 (5'5") (Short)	2,600 (8'6")					450 (18")		2,320 (7'7")			5,780 (18'12")
SK115SR	2,200 (7'3") (STD)	2,690 (8'10")	R1,385 (4'7")	3,320 (10'11")	2,410 (7'11")	2,740 (9')	600 (24")	455 (1'6")	2,590 (8'6")	910 (2'12")	1,960 (6'5")	6,880 (22'6")
	1,900 (6'3") (Short)	2,680 (8'9")					500 (20")		2,490 (8'2")			6,890 (22'7")
	2,700 (8'10") (Long)	2,780 (9'1")					700 (28")		2,690 (8'10")			6,890 (22'7")
SK135SR SK135SRLC	2,450 (8') (STD)	2,730 (8'11")	R1,425 (4'8")	STD 3,570 (11'9") LC 3,740 (12'3")	2,410 (7'11")	2,740 (9')	500 (20")	455 (1'6")	2,490 (8'2")	910 (2'12")	1,960 (6'5")	STD 7,360 (24'2") LC 7,440 (24'5")
	2,100 (6'11") (Short)	2,720 (8'11")					600 (24")		2,590 (8'6")			STD 7,360 (24'2") LC 7,440 (24'5")
	2,950 (9'8") (Long)	2,750 (9'1")					700 (28")		2,690 (8'10")			STD 7,390 (24'3") LC 7,470 (24'6")
SK235SR	2,940 (9'7") (STD)	2,950 (9'8")	R1,620 (5'4")	4,260 (13'12")	3,000 (9'10")	3,070 (10'1")	600 (24")	450 (1'5")	2,990 (9'9")	1,040 (3'5")	2,280 (7'6")	8,710 (28'7")
	2,400 (7'10") (Short)	3,100 (10'2")					700 (28")		3,090 (10'1")			8,810 (28'11")
	3,300 (10'10") (Long)	2,950 (9'8")					800 (32")		3,190 (10'5")			8,750 (28'8")

NOTE : Dimensions marked ※ do not include the height of the shoe lug.

# SK115SRDZ(KAI) SK135SRLC(KAI)

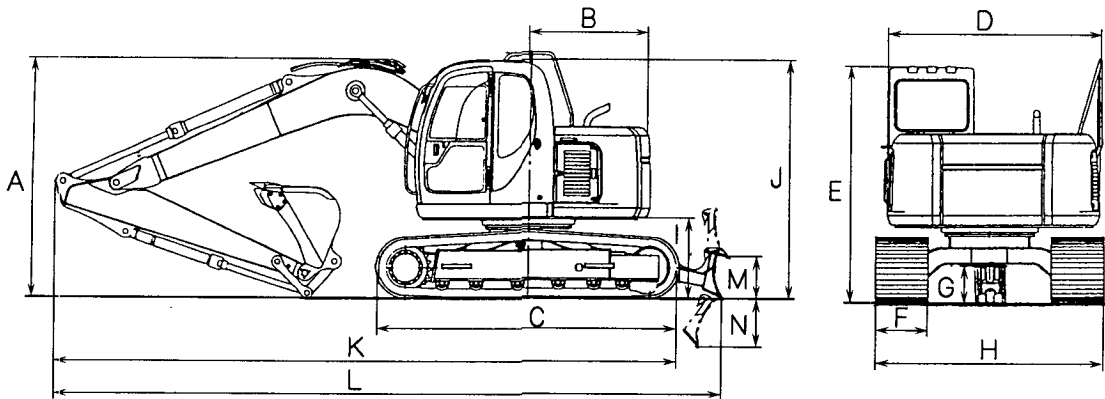

Model	Outside Dimension														
	Arm length	A	B	C	D	E	F	G	H	I(※)	J	K	L	M	N
SK115SRDZ (KAI)	2,450 (8'0") (STD)	2,730 (8'11")					600 (24")		2,590 (8'6")			7,360 (24'2")	7,880 (25'10")	490 (1'11")	540 (1'9")
	2,100 (6'11") (Short)	2,720 (8'11")	R1,425 (4'8")	3,570 (11'9")	2,410 (7'11")	2,740 (9')		455 (1'6")		910 (2'12")	1,960 (6'5")	7,360 (24'2")	7,880 (25'10")	490 (1'11")	540 (1'9")
	2,950 (9'8") (Long)	2,750 (9'1")					700 (28")		2,690 (8'10")			7,390 (24'3")	7,910 (25'11")	490 (1'11")	540 (1'9")
SK135SRLC (KAI)	2,950 (9'8") (STD)	2,780 (9'1")					600 (24")		2,590 (8'6")			7,470 (4'6")	—	—	—
	2,100 (6'11") (Short)	2,750 (9'1")	R1,425 (4'8")	3,740 (12'3")	2,410 (7'11")	2,740 (9')		455 (1'6")		910 (2'12")	1,960 (6'5")	7,440 (24'5")	—	—	—
	2,450 (8'0")	2,760 (9'1")					700 (28")		2,690 (8'10")			7,440 (24'5")	—	—	—

NOTE : Dimensions marked ※ do not include the height of the shoe lug.

SK115SRDZ Dozer : Standard

## 2. MACHINE SPECIFICATION TABLE

### PERFORMANCE

ITEM		MODEL	SK70SR		SK115SR		
STD bucket capacity	m <sup>3</sup> {cu-yd}		0.22 (0.29)		0.45 (0.59)		
Bucket capacity range	m <sup>3</sup> {cu-yd}		0.11 (0.14)~0.35 (0.46)		0.17 (0.22)~0.50 (0.65)		
Travel speed	km/h		Iron shoe 3.4/5.3	Rubber shoe 3.5/5.3	Iron shoe 3.5/6.0	Rubber shoe 3.8/6.3	
Swing speed	min <sup>-1</sup> rpm		12.5 {12.5}		11.4 {11.4}		
Gradeability	% (deg)		70 (35)		70 (35)		
Drawbar pulling force	kN {ton}		52.0 {5.3}		95.1 {9.7}		
Digging force	Bucket	kN {kgf}	52.9 {5,400}	52.9 {5,400}	85.5 {8,720}	85.5 {8,720}	85.5 {8,720}
	Arm	kN {kgf}	34.7 {3,540}	39.2 {4,000}	66.9 {6,820}	58.8 {6,000}	51.9 {5,300}
	Arm length	mm	2,070	1,650	1,900	2,200	2,700

### DIMENSIONS AND WEIGHT

Operating weight (Shoe width)		ton	7.1 (600mm)		11.8 (500mm) · 11.9 (600mm)		
Dimensions for Transportation	Arm length	mm	2,070	1,650	1,900	2,200	2,700
	Overall length	mm	5,790	5,780	6,890	6,880	6,890
	Overall width	mm	2,470		2,490		2,590
	Overall height	mm	2,600	2,600	2,740	2,740	2,740
Upper	Cab height from G.L.	mm	2,600		2,740		
	Tail height from G.L.	mm	750		910		
	Tail swing radius	mm	1,160		1,385		
	Min. front swing radius	mm	1,750		2,330		
Lower	Overall length of crawler	mm	2,860		3,320		
	Crawler wheel centers	mm	2,240		2,610		
	Track gauge	mm	1,870		1,990		
	Overall width of crawler	mm	2,470		2,490		2,590
	Width of shoes	mm/kPa	Grouser	450 / 31 {0.32}		Grouser	500 / 40 {0.41}
Ground pressure	{kgf/cm <sup>2</sup> }	600 / 25 {0.25}		600 / 34 {0.35}			
Ground clearance		mm	400		455		

### ENGINE

Model	ISUZU A-4JB1	ISUZU A-4BG1	
Rated power output	kW/min <sup>-1</sup> {PS/rpm}	40.4 / 2,100 {55 / 2,100}	58.8 / 2,100 {80 / 2,100}
Max. torque	N·m/min <sup>-1</sup> {kgf·m/rpm}	19.2 / 1,600 {188 / 1,600}	293 / 1,500 {29.9 / 1,500}
Displacement	ℓ	2,771	
Capacity of fuel tank	ℓ	85	
		160	

### HYDRAULIC SYSTEM

Type of pumps	Variable displacement axial piston + gear pump		
Set pressure of system	MPa {kgf/cm <sup>2</sup> }	29.4 {300}	32.4 {330}
Swing motor	Axial piston motor		
Travel motor	2-speed axial piston motor		
Control valves	6-spool Multiple control valve		
Capacity of Hyd. oil tank (Proper level)	ℓ	78 (55)	140 (94)

### WORKING RANGES

Arm length	mm	STD	Short	Short	STD	Long
Arm length	mm	2,070	1,650	1,900	2,200	2,700
Bucket capacity	m <sup>3</sup> {cu-yd}	0.22 (0.29)	0.28 (0.37)	0.50 (0.65)	0.45 (0.59)	0.37 (0.48)
Max. digging reach	mm	6,710	6,310	7,430	7,710	8,180
Max. digging depth	mm	4,520	4,100	4,760	5,060	5,560
Max. vertical wall digging depth	mm	3,970	3,540	3,960	4,500	4,860
Max. digging height	mm	7,500	7,180	7,960	8,160	8,490
Max. dumping clearance	mm	5,430	5,120	5,570	5,780	6,100

# SK135SR(LC)

## PERFORMANCE

ITEM		MODEL	SK135SR			SK135SR (LC)		
STD bucket capacity	m <sup>3</sup> {cu·yd}		0.50 (0.65)			0.50 (0.65)		
Bucket capacity range	m <sup>3</sup> {cu·yd}		0.24 (0.31) ~ 0.57 (0.75)			0.24 (0.31) ~ 0.57 (0.75)		
Travel speed	km/h		Iron shoe 3.5/6.0	Rubber shoe 3.8/6.4		Iron shoe 3.5/6.0	Rubber shoe 3.8/6.4	
Swing speed	min <sup>-1</sup> rpm		11.7 {11.7}			11.7 {11.7}		
Gradeability	% (deg)		70 (35)			70 (35)		
Drawbar pulling force	kN {ton}		100.0 {10.2}			100.0 {10.2}		
Digging force	Bucket	kN {kgf}	88.2 {8,990}	88.2 {8,990}	88.2 {8,990}	88.2 {8,990}	88.2 {8,990}	88.2 {8,990}
	Arm	kN {kgf}	71.7 {7,310}	63.6 {6,490}	58.0 {2,920}	71.7 {7,310}	63.6 {6,490}	58.0 {2,920}
	Arm length	mm	2,100	2,450	2,950	2,100	2,450	2,950

## DIMENSIONS AND WEIGHT

Operating weight (Shoe width)		ton	13.4(500mm) · 13.7(600mm) · 13.9(700mm)			13.9 (600mm)		
Dimensions for Transportation	Arm length	mm	2,100	2,450	2,950	2,100	2,450	2,950
	Overall length	mm	7,360	7,360	7,390	7,440	7,440	7,470
	Overall width	mm	2,490(500mm) · 2,590(600mm) · 2,690(700mm)			2,590		
	Overall height	mm	2,740	2,810	2,740	2,810	2,810	2,810
Upper	Cab height from G.L.	mm	2,740			2,740		
	Tail height from G.L.	mm	910			910		
	Tail swing radius	mm	1,425			1,425		
	Min. front swing radius	mm	2,380			2,380		
Lower	Overall length of crawler	mm	3,570			3,740		
	Crawler wheel centers	mm	2,865			3,035		
	Track gauge	mm	1,990			1,990		
	Overall width of crawler	mm	2,490(500mm)	2,590(600mm)	2,690(700mm)	2,590		
	Width of shoes	mm/kPa	Grouser	500 / 42 {0.43}			Grouser	600 / 35 {0.35}
Ground pressure	{kgf/cm <sup>2</sup> }	600 / 36 {0.37}						
		700 / 31 {0.32}						
Ground clearance	mm	455			455			

## ENGINE

Model	ISUZU A-4BG1T	ISUZU A-4BG1T
Rated power output	kW/min <sup>-1</sup> {PS/rpm}	62.5 / 2,050 {85 / 2,050}
Max. torque	N·m/min <sup>-1</sup> {kgf·m/rpm}	318 / 1,600 {32.4 / 1,600}
Displacement	ℓ	4,329
Capacity of fuel tank	ℓ	160

## HYDRAULIC SYSTEM

Type of pumps	Variable displacement axial piston + gear pump	
Set pressure of system	MPa {kgf/cm <sup>2</sup> }	34.3 {350}
Swing motor	Axial piston motor	
Travel motor	2-speed axial piston motor	
Control valves	6-spool Multiple control valve	
Capacity of Hyd. oil tank (Proper level)	ℓ	140 (94)

## WORKING RANGES

Item	mm	Short	STD	Long	Short	STD	Long
		Arm length	2,100	2,450	2,950	2,100	2,450
Bucket capacity	m <sup>3</sup> (cu·yd)	0.57 (0.75)	0.50 (0.65)	0.38 (0.50)	0.57 (0.75)	0.50 (0.65)	0.38 (0.50)
Max. digging reach	mm	8,030	8,340	8,770	8,030	8,340	8,770
Max. digging depth	mm	5,160	5,520	6,010	5,160	5,520	6,010
Max. vertical wall digging depth	mm	4,580	4,960	5,250	4,580	4,960	5,250
Max. digging height	mm	8,460	8,630	8,860	8,460	8,630	8,860
Max. dumping clearance	mm	6,020	6,200	6,440	6,020	6,200	6,440

# SK115SRDZ(KAI) SK135SRLC(KAI)

## PERFORMANCE

ITEM		MODEL	SK115SRDZ			SK135SRLC		
STD bucket capacity	m <sup>3</sup> {cu·yd}		0.24 (0.31) ~ 0.57 (0.75)			0.24 (0.31) ~ 0.57 (0.75)		
Bucket capacity range	m <sup>3</sup> {cu·yd}		0.50 (0.65)			0.38 (0.50)		
Travel speed	km/h		Iron shoe 3.5/6.0 Rubber shoe 3.8/6.4			Iron shoe 3.5/6.0 Rubber shoe 3.8/6.4		
Swing speed	min <sup>-1</sup> rpm		11.7 {11.7}			11.7 {11.7}		
Gradeability	% (deg)		70 (35)			70 (35)		
Drawbar pulling force	kN {ton}		100.0 {10.2}			100.0 {10.2}		
Digging force	Bucket	kN {kgf}	88.2 {8,990}	88.2 {8,990}	88.2 {8,990}	95.0 {9,690}		
	Arm	kN {kgf}	71.7 {7,310}	63.6 {6,490}	58.0 {2,920}	58.1 {5,920}		
	Arm length	mm	2,100	2,450	2,950	2,100	2,950	2,450

## DIMENSIONS AND WEIGHT

Operating weight (Shoe width)		ton	14.4 (600mm)			14 (600mm)		
Dimensions for Transportation	Arm length	mm	2,100	2,450	2,950	2,100	2,950	2,450
	Overall length	mm	7,360	7,360	7,390	7,440	7,470	7,440
	Overall width	mm	2,590			2,590		
	Overall height	mm	2,810	2,810	2,810	2,810	2,810	2,810
Upper	Cab height from G.L.	mm	2,740			2,740		
	Tail height from G.L.	mm	910			910		
	Tail swing radius	mm	1,425			1,425		
	Min. front swing radius	mm	2,380			2,380		
Lower	Overall length of crawler	mm	3,570			3,740		
	Crawler wheel centers	mm	2,865			3,035		
	Track gauge	mm	1,990			1,990		
	Overall width of crawler	mm	2,590			2,590		
	Width of shoes	mm/kPa	Grouser	600 / 38 {0.39}		Grouser	600 / 35 {0.36}	
Ground pressure	{kgf/cm <sup>2</sup> }							
Ground clearance	mm	455			455			

## ENGINE

Model	ISUZU A-4BG1T	ISUZU A-4BG1T	
Rated power output	kW/min <sup>-1</sup> {PS/rpm}	62.7 / 2,050 {85.2 / 2,050}	70.1 / 2,200 {95.3 / 2,200}
Max. torque	N·m/min <sup>-1</sup> {kgf·m/rpm}	318 / 1,600 {32.4 / 1,600}	318 / 1,600 {32.4 / 1,600}
Displacement	ℓ	4,329	4,329
Capacity of fuel tank	ℓ	160	160

## HYDRAULIC SYSTEM

Type of pumps	Variable displacement axial piston + gear pump		
Set pressure of system	MPa {kgf/cm <sup>2</sup> }	34.3 {350}	34.3 {350}
Swing motor	Axial piston motor		
Travel motor	2-speed axial piston motor		
Control valves	6-spool Multiple control valve		
Capacity of Hyd. oil tank (Proper level)	ℓ	140 (94)	140 (94)

## WORKING RANGES

Arm length	mm	Short	STD	Long	Short	STD	—
		2,100	2,450	2,950	2,100	2,950	2,450
Bucket capacity	m <sup>3</sup> (cu·yd)	0.57 (0.75)	0.50 (0.65)	0.38 (0.50)	0.57 (0.75)	0.38 (0.50)	0.50 (0.65)
Max. digging reach	mm	8,030	8,340	8,770	8,030	8,770	8,340
Max. digging depth	mm	5,160	5,520	6,010	5,160	6,010	5,520
Max. vertical wall digging depth	mm	4,580	4,960	5,250	4,580	5,250	4,960
Max. digging height	mm	8,460	8,630	8,860	8,460	8,860	8,630
Max. dumping clearance	mm	6,020	6,200	6,440	6,020	6,440	6,200

# SK235SR

## PERFORMANCE

ITEM	MODEL	SK235SR			
STD bucket capacity	m <sup>3</sup> {cu·yd}	0.80 (1.05)			
Bucket capacity range	m <sup>3</sup> {cu·yd}	0.51 (0.67)~0.93 (1.22)			
Travel speed	km/h	Iron shoe 3.3/5.3			
Swing speed	min <sup>-1</sup> rpm	13.0 {13.0}			
Gradeability	% (deg)	70 {35}			
Drawbar pulling force	kN {ton}	185.3 {18.9}			
Digging force	Bucket	kN {kgf}	135 {13,800} at boost 149 {15,200}	135 {13,800} at boost 149 {15,200}	135 {13,800} at boost 149 {15,200}
	Arm	kN {kgf}	115 {11,700} at boost 126 {12,900}	97 {9,900} at boost 107 {10,900}	92.2 {9,400} at boost 10 {10,300}
	Arm length	mm	2,400	2,940	3,300

## DIMENSIONS AND WEIGHT

Operating weight (Shoe width)		ton	23.2 (600mm)		
Arm length		mm	2,400	2,940	3,300
Dimensions for Transportation	Overall length	mm	8,810	8,710	8,750
	Overall width	mm	2,990		
	Overall height	mm	3,070	3,070	3,070
	Cab height from G.L.	mm	3,070		
Upper	Tail height from G.L.	mm	1,040		
	Tail swing radius	mm	1,620		
	Min. front swing radius	mm	1,900		
	Overall length of crawler	mm	4,260		
Lower	Crawler wheel centers	mm	3,470		
	Track gauge	mm	2,390		
	Overall width of crawler	mm	2,990		
	Width of shoes	mm/kPa	Grouser	600 / 50 {0.51}	
	Ground pressure	{kgf/cm <sup>2</sup> }		700 / 43 {0.44}	
		800 / 38 {0.39}			
Ground clearance		mm	450		

## ENGINE

Model	MITSUBISHI 6D34-TE1		
Rated power output	kW/min <sup>-1</sup> {PS/rpm}	107 / 2,000 {145 / 2,000}	
Max. torque	N·m/min <sup>-1</sup> {kgf·m/rpm}	519 / 1,600 {53 / 1,600}	
Displacement	ℓ	5,861	
Capacity of fuel tank	ℓ	290	

## HYDRAULIC SYSTEM

Type of pumps	Variable displacement axial piston + gear pump		
Set pressure of system	MPa {kgf/cm <sup>2</sup> }	34.3 {350} at boost 37.7 {385}	
Swing motor	Axial piston motor		
Travel motor	2-speed axial piston motor		
Control valves	6-spool Multiple control valve		
Capacity of Hyd. oil tank (Proper level)	ℓ	195 (125)	

## WORKING RANGES

		Short	STD	Long
Arm length	mm	2,400	2,940	3,300
Bucket capacity	m <sup>3</sup> (cu·yd)	0.93 (1.22)	0.80 (1.05)	0.68 (0.89)
Max. digging reach	mm	9,370	9,850	10,210
Max. digging depth	mm	6,160	6,700	7,100
Max. vertical wall digging depth	mm	5,520	6,060	6,480
Max. digging height	mm	10,890	11,290	11,590
Max. dumping clearance	mm	8,030	8,420	8,690

## 3. MAJOR SPECIFICATIONS

SK70SR

### 3-1 ● ENGINE SPECIFICATIONS

#### Principal items

Model		SK70SR		
Engine model		ISUZU A-4JB1		
Type		4-cycle water-cooled, in-line, Direct injection		
Number of cylinder — Bore × Stroke		4 — 93mm (3.66in) × 102mm (4.02in)		
Total displacement		2.771 cc (169cu-in)		
Compression ratio		18.2		
Rated out put		40.4kW / 2,100min <sup>-1</sup> {55PS / 2,100rpm}		
Maximum torque		19.2kgf·m / 1,600min <sup>-1</sup> (139ft·lbs / 1,600rpm)		
High idling		2,320±25min <sup>-1</sup> {2,320±25rpm}		
Low idling		1,000±20min <sup>-1</sup> {1,000±20rpm}		
Injection valve opening pressure		185kgf/cm <sup>2</sup> (2,632psi)		
Thermostat action		Opening 82°C (180°F) / Full open 95°C (203°F)		
Ignition order		1 - 3 - 4 - 2		
Compression pressure		30kgf/cm <sup>2</sup> (427psi) at 200rpm		
Lubrication oil pressure		—————		
Fuel injection timing		° (degree) 17±1° before top dead point		
Valve clearance, valve action timing		Valve clearance	Open	Close
	Intake valve	0.4mm (0.016") in cold condition	24.5° before the top dead point	55.5° after the bottom dead point
	Exhaust valve	0.4mm (0.016") in cold condition	54° before the bottom dead point	26° after the top dead point
Starter capacity		3.2kW × 24V		
Generator capacity (Alternator)		24V × 30A		
Cooling fan drive method		φ 450 (φ 17.7in) suction type seven fans V-belt drive, Pulley ratio Crank / Fan : 1.12		
Engine oil quantity		Full level 8ℓ (2.11 gal) Low level sensor actuation oil filter, etc.		
Dry weight		240kg (529lbs)		
Fuel consumption ratio		226g/kW·h {166g/PS·h}		
Allowable inclination		Back and forth, Right and left : 35°		
Engine dimension L × W × H mm (in)		760 × 620 × 710 (29.9 × 24.4 × 28)		
Rotating direction		Counterclockwise seeing from flywheel side		



**Suggest:**

**For more complete manuals. Please go to the home page.**

**<https://www.ebooklibonline.com>**

**If the above button click is invalid. Please download this document first, and then click the above link to download the complete manual.**

**Thank you so much for reading**

# SK70SR

SK70SR

## ● ENGINE CHARACTERISTIC CURVE (ISUZU 4JB1)

Condition to be measured : With fan and generator

Without muffler and air cleaner

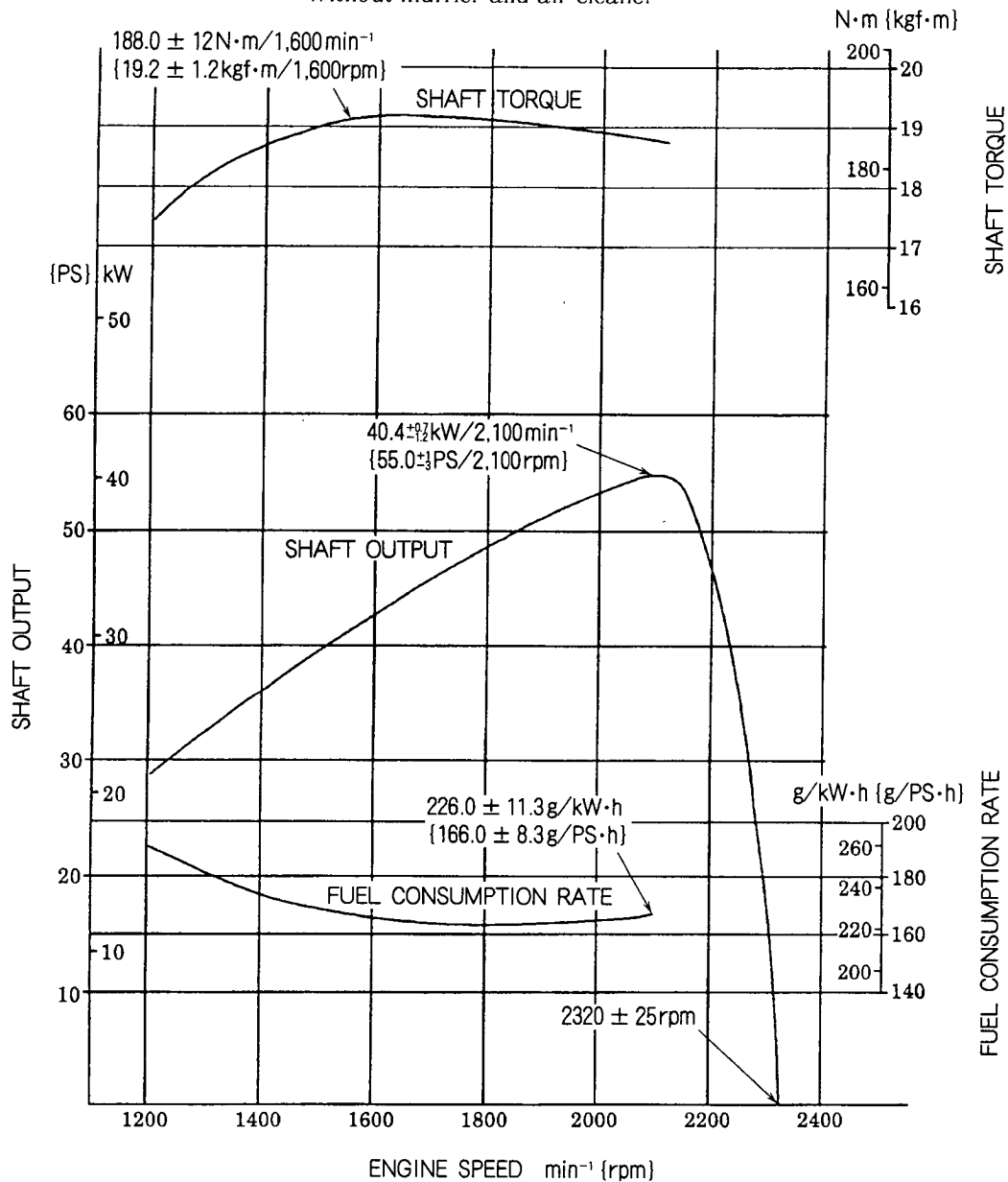

$$\text{Fuel consumption volume} = \frac{\text{Fuel consumption rate}}{0.835 \times 1000} \times \text{PS} \times \text{Load factor } (\alpha)$$

$$= \frac{166 \text{ g/PS}\cdot\text{h}}{0.835 \times 1000} \times 55 \text{ PS} \times \alpha$$

$$= 10.9 \alpha \cdot \ell / \text{h} \quad (2.8 \alpha \cdot \text{gal/h})$$

$\alpha$  : Standard load factor (0.60~0.70)

Fuel consumption in regular operation

(load factor : 0.60~0.70)

6.5 ~ 7.6  $\ell$  / h (1.7 ~ 2.0 gal/h)

## SK115SR

### ● ENGINE SPECIFICATIONS

#### Principal items

Model		SK115SR		
Engine model		ISUZU A-4BG1		
Type		4-cycle water-cooled, in-line, Direct injection		
Number of cylinder – Bore × Stroke		4 – 105 mm (4.13 in) × 125 mm (4.92 in)		
Total displacement		4,329cc (264cu-in)		
Compression ratio		17		
Rated out put		58.8±1.8kW / 2,100min <sup>-1</sup> {80±2.5PS / 2,100rpm}		
Maximum torque		29.9±2kgf·m / 1,500min <sup>-1</sup> (216ft·lbs / 1,500rpm)		
High idling		2,340±20min <sup>-1</sup> {2,340±20rpm}		
Low idling		850±20min <sup>-1</sup> {850±20rpm}		
Injection valve opening pressure		150kgf/cm <sup>2</sup> (2,134psi)		
Thermostat action		Opening 82°C (180°F) / Full open 95°C (203°F)		
Ignition order		1 – 3 – 4 – 2		
Compression pressure		31kgf/cm <sup>2</sup> (441psi) at 200rpm		
Lubrication oil pressure		—————		
Fuel injection timing ° (degree)		14° before top dead point		
Valve clearance, valve action timing		Valve clearance	Open	Close
	Intake valve	0.4mm (0.016") in cold condition	19° before the top dead point	47° after the bottom dead point
	Exhaust valve	0.4mm (0.016") in cold condition	57° before the bottom dead point	15° after the top dead point
Starter capacity		4.5kW × 24V		
Generator capacity (Alternator)		24V × 30A		
Cooling fan drive method		φ 550 (φ 22in) suction type sixth fans V-belt drive, Pulley ratio Crank / Fan : 1.09		
Engine oil quantity		Engine body 13 ℓ (Full) (3.44 gal) 11 ℓ (Low) (2.9gal)		
Dry weight		353kg (778lbs)		
Fuel consumption ratio		222±16g/kW·h {163±11g/PS·h}		
Allowable inclination		Back and forth, Right and left : 35°		
Engine dimension L × W × H mm (in)		860 × 670 × 850 (33.8 × 26.3 × 33.4)		
Rotating direction		Counterclockwise seeing from flywheel side		

**<https://www.ebooklibonline.com>**

Hello dear friend!

Thank you very much for reading.

Enter the link into your browser.

The full manual is available for immediate download.

**<https://www.ebooklibonline.com>**