

HYDRAULIC EXCAVATOR

SHOP
MANUAL model SK850LC

INDEX

1	SPECIFICATIONS SECTION
2	MAINTENANCE SECTION
3	SYSTEM SECTION
4	DISASSEMBLY SECTION
5	TROUBLESHOOTING
6	ENGINE SECTION

KOBELCO

Book Code No.S5LY0004E03

Book Code No. Distribution Year–Month			Title	Index No.
S5YN0129E01 2009-11		SPECIFICATIONS	OUTLINE	1
S5LY0204E02 2010-10			SPECIFICATIONS	2
S5LY0304E01 2009-11			ATTACHMENT DIMENSIONS	3
S5LY1104E01 2009-11		MAINTENANCE	TOOLS	11
—				
S5LY1304E01 2009-11		SYSTEM	MAINTENANCE STANDARD AND TEST PROCEDURE	13
S5LY2104E01 2009-11			MECHATRO CONTROL SYSTEM	21
S5LY2204E01 2009-11			HYDRAULIC SYSTEM	22
S5LY2304E01 2009-11			ELECTRIC SYSTEM	23
S5LY2404E01 2009-11			COMPONENTS SYSTEM	24
S5LY2504E01 2009-11			AIR-CONDITIONER SYSTEM	25
—				
S5YN3129E01 2009-11		DISASSEMBLING	DISASSEMBLING & ASSEMBLING	31
S5LY3204E01 2009-11			ATTACHMENT	32
S5LY3304E01 2009-11			UPPER STRUCTURE	33
S5LY3404E02 2011-06			TRAVEL SYSTEM	34
S5LY4604E01 2009-11		TROUBLESHOOTING	BY ERROR CODES	46
S5LY4704E01 2009-11			BY TROUBLE	47
—				
—				
S5LY5104E01 2009-11		E/G	ENGINE	51
—				
—				
—				
LY02-00151~			APPLICABLE MACHINES	

33

25

1

34

2

51

11

3

21

13

46

22

47

31

23

32

24

NOTE:

This Manual is prepared as a technical material in which the information necessary for the maintenance and repairing services of our hydraulic excavators are collected, and is categorized into 7 Chapters, Specification, Maintenance, System, Disassembly, Troubleshooting, Engine, and Installation Procedures for Optional Attachment.

- The Chapter "Specification" describes the specifications for entire machine and material, which are instructive for replacement and repairing of attachments.
- The Chapter "Maintenance" describes the material, which is helpful for maintenance service and adjustments for entire machine.
- The Chapter "System" describes the operating system like hydraulic system, electric system, components, and so on.
- The Chapter "Disassembly" describes the removal and installing of assembly mounted on the upper structure and undercarriage, and the assembling and disassembling of the associated hydraulic equipment.
- The Chapter "Troubleshooting" describes how to find the fault equipment.
- The Chapter "Engine" describes the engines making use of the "Maintenance Manual" provided by the suppliers.
- The Chapter "Installation Procedures for Optional Attachment" describes the supplements added on request as required.

This Manual may be properly revised due to the improvement of products, modification of specifications, etc. And there are cases where the system on actual machine and a part of the contents of this manual may differ due to the variations of specification by countries. For the section in which the description is hardly understood, contact our distributor.

The number is assigned to every part handled in this Manual on account of the description, but the parts, which cannot be supplied as service parts are contained. Therefore, the order must be placed with respective formal number with due confirmation on the Parts Manual for applicable machine.

<https://www.ebooklibonline.com>

Hello dear friend!

Thank you very much for reading.

Enter the link into your browser.

The full manual is available for immediate download.

<https://www.ebooklibonline.com>

1. OUTLINE

TABLE OF CONTENTS

1.1 GENERAL PRECAUTIONS FOR MAKING REPAIRS	1-3
1.1.1 PREPARATION BEFORE DISASSEMBLING	1-3
1.1.2 SAFETY WHEN DISASSEMBLING AND ASSEMBLING	1-3
1.1.3 DISASSEMBLING AND ASSEMBLING HYDRAULIC EQUIPMENT	1-4
1.1.4 ELECTRICAL EQUIPMENT	1-6
1.1.5 HYDRAULIC PARTS	1-7
1.1.6 WELD REPAIR	1-7
1.1.7 ENVIRONMENTAL ISSUES	1-7
1.2 INTERNATIONAL UNIT SYSTEM	1-8

[1. OUTLINE]

Issue	Date of Issue	Applicable Machines	Remarks
First Edition	December, 2008	SK200-8 : YN12-56001~ SK210LC-8 : YQ12-08001~	S5YN0129E01 (SE Asia & Oceania)
↑	February, 2009	E215B : YN12-56001~ E215BLC : YQ12-08001~	↑ NHK-RUS (HS Engine)
↑	↑	E215B : YN12-56001~ E215BLC : YQ12-08001~	↑ NHK-Mid.East & Afr. (HS Engine)
↑	↑	E215B : YN12-56001~ E215BLC : YQ12-08001~	↑ (NHK-TUR)
↑	↑	SK330-8 : LC11-08501~	↑ SE Asia (HS Engine)
↑	↑	E265B : LQ13-07001~ E265BLC : LL13-06001~	↑ NHK-RUS (HS Engine)
↑	↑	E265B : LQ13-07001~ E265BLC : LL13-06001~	↑ NHK-Mid.East & Afr. (HS Engine)
↑	↑	E265B : LQ13-07001~ E265BLC : LL13-06001~	↑ (NHK-TUR)
↑	↑	SK460-8 : LS11-02501~ SK480LC-8 : YS11-02001~	↑ (SE Asia & Oceania)
↑	March, 2009	E385B : LC11-08501~ E385BLC : YC11-04501~	↑ NHK-RUS (HS Engine)
↑	↑	E385B : LC11-08501~ E385BLC : YC11-04501~	↑ NHK-Mid.East & Afr. (HS Engine)
↑	↑	SK460-8 : LS11-02501~ SK480LC-8 : YS11-02001~	↑ SE Asia (HS Engine)
↑	April, 2009	E235BSR : YF06-02501~ E235BSR(N)LC : YU06-03001~	↑ (NHK-EUR)
↑	↑	SK235SRLC-2 : YU06-03001~	↑ (NA)
↑	May, 2009	SK235SR-2 : YF06-02501~ SK235SRLC-2 : YU06-03001~	↑ (OCE)
↑	June, 2009	SK125SR : YV06-05501~ SK125SRL : LD06-01801~ SK135SR-2 : YY06-15001~ SK135SRLC-2 : YH06-08001~	↑ (SE Asia & Oceania)
↑	July, 2009	SK140LC-8 : YP09-05001~	↑ (SE Asia)
↑	↑	SK70SR-2 : YT06-18001~	↑ (SE Asia & Oceania)
↑	August, 2009	SK80MSR-2 : LF06-04501~	↑ (Oceania)
↑	September, 2009	SK225SR : YB06-03501~ SK225SRLC : LA06-02501~	↑ (OCE)
↑	November, 2009	SK850LC : LY02-00151~	↑ (SE Asia)

1.1 GENERAL PRECAUTIONS FOR MAKING REPAIRS

1.1.1 PREPARATION BEFORE DISASSEMBLING



(1) Knowledge of operating procedure

Read Operator's Manual carefully to understand the operating procedure.

(2) Cleaning machines

Clean machines of soil, mud, and dust before carrying into the service shop. Carrying a soiled machine into the service shop, causes making less efficient work and damage of parts.

(3) Inspecting machines

Confirm the disassembling section before starting work, determine the disassembly procedure taking the conditions in work shop into account, and request to procure necessary parts in advance.

(4) Recording

Record the following items to keep contact and prevent malfunction from recurring.

1. Inspecting date, place
2. Model name, Serial number and Record on hour meter
3. Trouble condition, place, cause
4. Visible oil leak, water leak and damage
5. Clogging of filters, oil level, oil quality, oil contamination and looseness.
6. Examine the problems on the basis of monthly operation rate with the last inspection date and records on hour meter.

(5) Arrangement and cleaning in service shop

1. Tools required for repair work.
2. Prepare the places to put the disassembled parts.
3. Prepare oil pans for leaking oil, etc.

1.1.2 SAFETY WHEN DISASSEMBLING AND ASSEMBLING



(1) Safety

1. Wear appropriate clothing, safety shoes, safety helmet, goggles, and clothes with long sleeves.
2. Attach "Don't operate" tag to control lever, and begin a meeting before starting the work.
3. Before starting inspection and maintenance stop the engine.
4. Confirm the position of first-aid kit and fire extinguisher, and also where to make contact for emergency measure and ambulance to prepare for accidents and fire.
5. Choose a hard, level and safe place, and put attachment on the ground without fail.
6. Use hoist, etc. to remove parts of heavy weight (23kg [50 lb] or more).
7. Use proper tools, and change or repair defective tools.
8. Machine and attachment required to work in the lifting condition should be supported with supports or blocks securely.

1.1.3 DISASSEMBLING AND ASSEMBLING HYDRAULIC EQUIPMENT



(1) Removing hydraulic equipment assy

1. Before removing pipes, release the pressure of hydraulic oil tank, or open the cover on the return side to tank, and take out the filter.
2. Drain the oil in the removed pipes into pan to prevent the oil from spilling on the ground.
3. Pipes with plugs or caps to prevent oil leaking, entry of dust, etc.
4. Clean the outside surface of equipment, etc. before disassembling, and drain hydraulic oil and gear oil before putting them on working bench.

(2) Disassembling hydraulic equipment

1. Since performance and function of hydraulic equipment after disassembly and assembly results in immunity from responsibility on the manufacture's side, disassembly, assembly and modification without permission are strictly prohibited.
2. If it is unavoidably necessary to disassemble and modify, it should be carried out by experts or personnel qualified through service training.
3. Make match mark on parts for reassembling.
4. Before disassembling, read Disassembling Instruction in advance, and determine if the disassembly and assembly are permitted or not.
5. For parts which are required to use jig and tools, don't fail to use the specified jig and tools.
6. For parts which can not be removed in the specified procedure, never force removal. First check for the cause.
7. The removed parts should be put in order and tagged so as to install on proper places without confusion.
8. For common parts, pay attention to the quantity and places.

(3) Inspecting parts

1. Check that the disassembled parts are free from adherence, interference and uneven working face.
2. Measure the wear of parts and clearance, and record the measured values.
3. If an abnormality is detected, repair or replace the parts.

(4) Reassembling hydraulic equipment

1. During the parts cleaning, ventilate the room.
2. Before assembly, clean parts roughly first, and then completely.
3. Remove adhering oil by compressed air, and apply hydraulic oil or gear oil, and then assemble them.
4. Replace the removed O-ring, back-up rings and oil seal with new ones, and apply grease oil on them before assembling.
5. Removes dirt and water on the surface on which liquid sealant are applied, decrease them, and apply liquid sealant on them.
6. Before assembling, remove rust preventives on new parts.
7. Use special tools to fit bearings, bushing and oil seal.
8. Assemble parts matching to the marks.
9. After completion, check that there is no omission of parts.

(5) Installing hydraulic equipment

1. Confirm hydraulic oil and lubrication oil.
2. Air release is required in the following cases ;
 - a. Change of hydraulic oil
 - b. Replacement of parts on suction pipe side
 - c. Removing and attaching hydraulic pump
 - d. Removing and attaching swing motor
 - e. Removing and attaching travel motor
 - f. Removing and attaching hydraulic cylinder
3. For air bleed of hydraulic pump and swing motor, loosen drain plug on the upper part, start engine, and run in low idling, then bleed air until hydraulic oil is comes out. After completion of comes, tighten plug securely.
4. For air bleed of travel motor and hydraulic cylinder, starts engine and operate it for 10 minutes or more at no-load and low speed.
5. Air in pilot circuit can be bled out by only operating digging, swing and traveling motions thoroughly.
6. Check hydraulic oil level.
 Move attachments to hydraulic oil check position, and check hydraulic oil level of tank. Refill oil if the oil level is lower than the specified level.
 How to check oil level of hydraulic oil tank

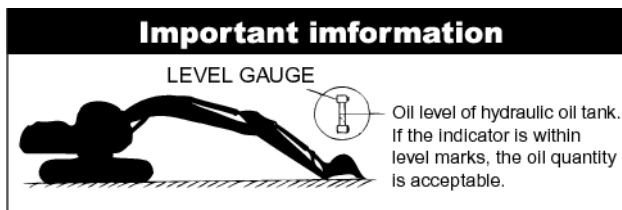
**⚠ WARNING**

If hydraulic oil and lubricating oil are not filled and also air bleed is not performed, the hydraulic equipment may be damaged.

⚠ WARNING

For cylinder, don't move it to the stroke end at beginning.

1.1.4 ELECTRICAL EQUIPMENT

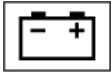

- (1) The disassembly of electrical equipment is not allowed.
- (2) Handle equipment with care so as not to drop it or bump it.
- (3) Connector should be removed by unlocking while holding the connector.
Never stress in tension to the caulked section by pulling wire.
- (4) Check that connector is connected and locked completely.
- (5) Engine key off before removing and connecting connector.
- (6) Engine key off before touching terminals of starter and alternator.
- (7) Remove battery grounding terminal before beginning work close to battery and battery relay with tools.
- (8) Wash machine with care so as not to splash water on electrical equipment and connector.
- (9) When water has entered in the waterproofed connector, the removing of water is not easy. So check the removed waterproofed connector with care to protect it from entry of water. If moisture adheres on it, dry it completely before connecting.



Battery fluid is dangerous.

The battery fluid is dilute sulfuric acid, and causes scald and loss of eyesight by adhering on eyes, skin and clothes. When the fluid has adhered on them, take an emergency measure immediately and see a doctor for medical advice.

-When it has adhered on skin; Wash with soap and water.

-When it has got in eyes; Wash in water for 10 minutes or more immediately.

-When it has spilled out in large quantity; Use sodium bicarbonate to neutralize, or wash away with water.

-When it was swallowed; Drink milk or water.

-When it has adhered on clothes; Wash it immediately.

1.1.5 HYDRAULIC PARTS



(1) O-ring

- Check that O-ring is free from flaw and has elasticity before fitting.
- Even if the size of O-ring is equal, the usage differs, for example in dynamic and static sections, the rubber hardness also differs according to the pressure force, and also the quality differs depending on the materials to be seated. So, choose proper O-ring.
- Fit O-ring so as to be free from distortion and bend.
- Floating seal should be put in pairs.

(2) Flexible hose (F hose)

- Even if the connector and length of hose are the same, the parts differ according to the withstanding pressure. Use proper parts.
- Tighten it to the specified torque, and check that it is free from twist, over tension, interference, and oil leak.

1.1.6 WELD REPAIR

- (1) The weld repair should be carried out by qualified personnel in the specified procedure after disconnecting the grounding cable of battery. If the grounding cable is not disconnected, the electrical equipment may be damaged.
- (2) Remove parts which may cause fire due to the entry of spark beforehand.
- (3) Repair attachments which are damaged, giving particular attention to the plated section of piston rod to protect it from sparks, and don't fail to cover the section with flame-proof clothes.

1.1.7 ENVIRONMENTAL ISSUES

- (1) Engine should be started and operated in the place where air can be sufficiently ventilated.
- (2) Waste disposal
The following parts follows the regulation.
Waste oil, waste container and battery
- (3) Precautions for handling hydraulic oil
Hydraulic oil may cause inflammation of eyes.
Wear goggles to protect eyes on handling it.
-When it has got in eyes ;
Wash eyes with water until the stimulus is gone.
-When it was swallowed ;
Don't force him to vomit it, but immediately receive medical treatment.
-When it has adhered on skin ;
Wash with soap and water.
- (4) Others
For spare parts, grease and oil, use KOBELCO genuine ones.

1.2 INTERNATIONAL UNIT SYSTEM

Introduction

Although this manual uses the SI units system.

Outline of SI units system is described here.

Given hereinunder are an excerpt of the units that are related to this manual :

1. Etymology of SI Units

English : International System of units

2. Construction of SI Unit System

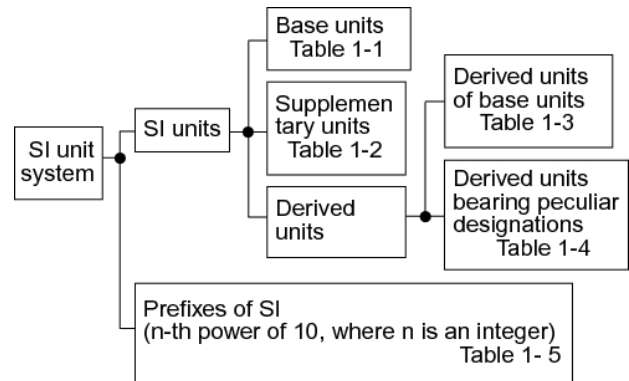

(1) Basic Units

Table1-1

QUANTITIES	DESIGNATION	SIGN
Length	Meter	m
Mass	Kilogram	kg
Time	Second	s
Current	Ampere	A
Thermodynamic temperature	Kelvin	K
Gram molecule	Mol	mol
Luminous intensity	Candela	cd

(2) Supplementary Units

Table1-2

QUANTITIES	DESIGNATION	SIGN
Plain angle	Radian	rad
Solid angle	Steradian	sr

(3) Derived Units of Basic Units

Table1-3

QUANTITIES	DESIGNATION	SIGN
Area	Square meter	m ²
Volume	Cubic meter	m ³
Velocity	Meter per second	m/s
Acceleration	Meter per second / second	m/s ²
Density	Kilogram per cubic meter	kg/m ³

(4) Derived Units bearing Peculiar Designations

Table1-4

QUANTITY	UNIT	SYMBOL	FORMULA
Frequency	hertz	Hz	1Hz=1/s
Force	newton	N	kg • m/s ²
Pressure and Stress	pascal	Pa	N/m ²
Energy, Work and Quantity of heat	joule	J	N•m
Power	watt	W	J/s
Quantity of electricity	coulomb	C	A•s
Electric potential difference, Voltage, and Electromotive force	volt	V	W/A
Quantity of static electricity and Electric capacitance	farad	F	C/V
Electric resistance	ohm	Ω	V/A
Celsius temperature	celcius degree or degree	°C	(t+273.15)K
Illuminance	lux	lx	l m/m ²

(5) Prefixes of SI

Table1-5

PREFIX		POWER
DESIGNATION	SIGN	
Giga	G	10^9
Mega	M	10^6
Kilo	k	10^3
Hecto	h	10^2
Deca	da	10
Deci	d	10^{-1}
Centi	c	10^{-2}
Milli	m	10^{-3}
Micro	μ	10^{-6}
Nano	n	10^{-9}
Pico	p	10^{-12}

(6) Unit Conversion Table

Table1-6

QUANTITIES	JIS	SI	REMARKS
Mass	kg	kg	
Force	kgf	N	1kgf=9.807N
Torque	kgf•m	N•m	1kgf•m=9.807N•m
Pressure	kgf/cm ²	MPa	1kgf/cm ² =0.098MPa
Motive power	PS	kW	1PS=0.7355kW
Revolution	r.p.m	min ⁻¹	1r.p.m=1min ⁻¹

2. SPECIFICATIONS

TABLE OF CONTENTS

2.1 NAME OF COMPONENTS	2-3
2.2 GENERAL DIMENSIONS	2-4
2.2.1 SK850LC [8.25m (27ft-1in) Boom+3.60m (11ft-10in) Standard Arm+3.50m ³ (4.58cu-yd) Bucket]	2-4
2.2.2 SK850LC [7.25m (23ft-9in) Boom+2.90m (9ft-6in) Arm+5.40m ³ (7.06cu-yd) Bucket]	2-4
2.2.3 SK850LC [8.25m (27ft-1in) Boom+4.40m (14ft-5in) Long Arm+2.80m ³ (3.66cu-yd) Bucket]	2-5
2.2.4 SK850LC [8.25m (27ft-1in) Boom+2.90m (9ft-6in) Short Arm+4.60m ³ (6.02cu-yd) Bucket]	2-5
2.2.5 SK850LC [7.25m (23ft-9in) Boom+2.90m (9ft-6in) Short Arm+4.30m ³ (5.62cu-yd) Bucket]	2-6
2.3 WEIGHT OF COMPONENTS	2-7
2.4 TRANSPOTATION	2-11
2.4.1 MACHINE PREPARATION.....	2-12
2.4.2 DIMENSIONS OF ATTACHMENT	2-13
2.5 LIFTING MACHINE	2-15
2.6 SPECIFICATIONS AND PERFORMANCE	2-16
2.6.1 SPEED AND CLIMBING CAPABILITY	2-16
2.6.2 ENGINE	2-16
2.6.3 HYDRAULIC COMPONENTS	2-16
2.6.4 WEIGHT	2-17
2.7 TYPE OF CRAWLER	2-18
2.7.1 SK850LC (3.60m Arm)	2-18
2.7.2 SK850LC (2.90m Arm)	2-18
2.8 ENGINE SPECIFICATION	2-19
2.8.1 SPECIFICATIONS	2-19
2.8.2 ENGINE CHARACTERISTIC CURVE (Komatsu SAA6D140E-5).....	2-20

[2. SPECIFICATIONS]

Issue	Date of Issue	Applicable Machines	Remarks
First edition	November, 2009	SK850LC : LY02-00151~	S5LY0204E01 (SE Asia)
Revision	October, 2010	SK850LC : LY02-00151~	S5LY0204E02 (SE Asia & India)

2.1 NAME OF COMPONENTS

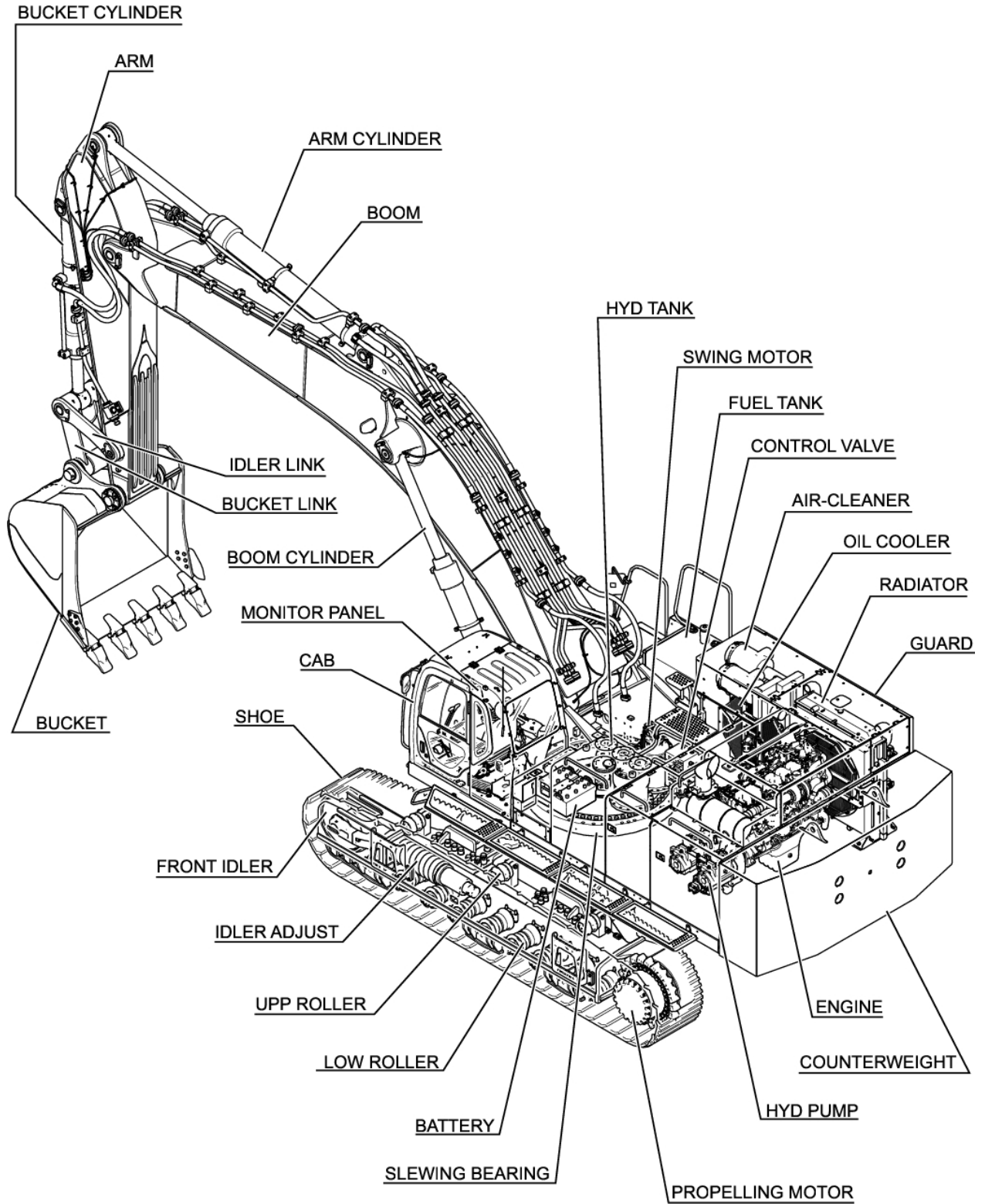

2.2 GENERAL DIMENSIONS

2.2.1 SK850LC [8.25m (27ft-1in) Boom+3.60m (11ft-10in) Standard Arm+3.50m³ (4.58cu-yd) Bucket]

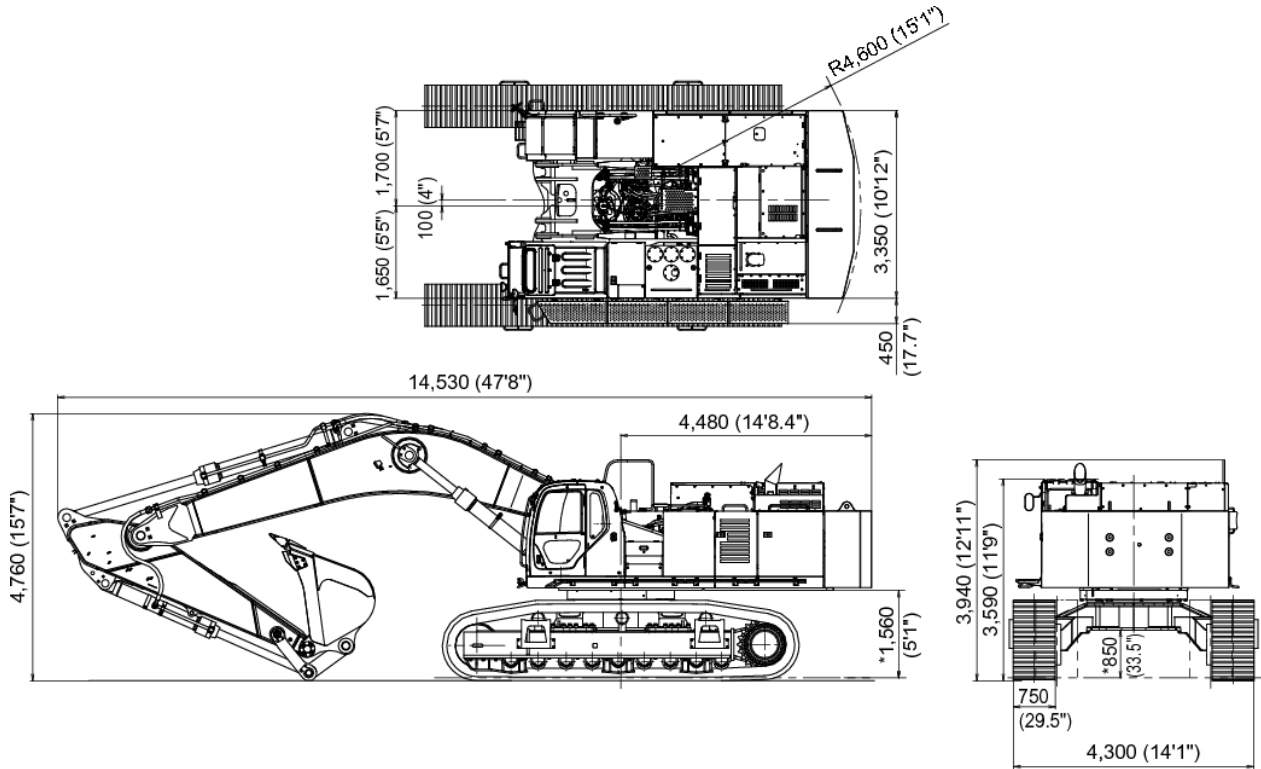

2.2.2 SK850LC [7.25m (23ft-9in) Boom+2.90m (9ft-6in) Arm+5.40m³ (7.06cu-yd) Bucket]

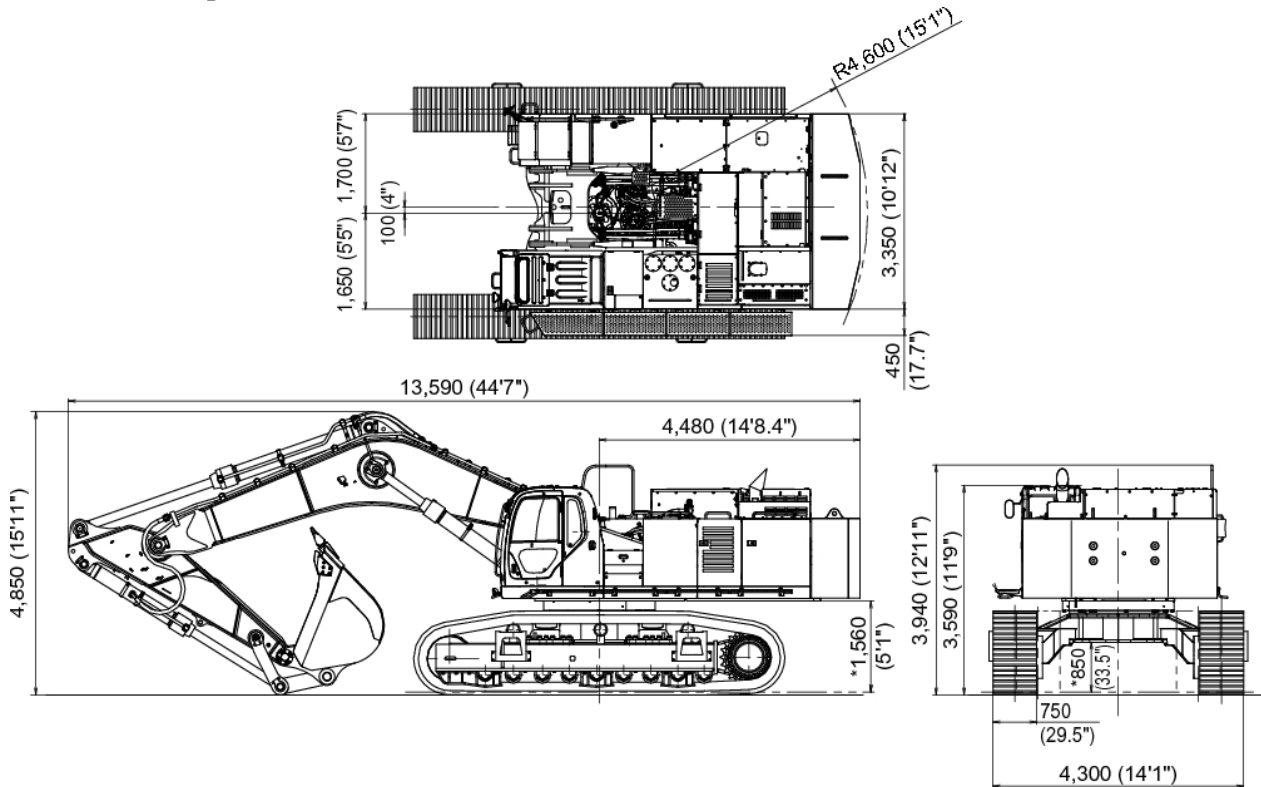

Note

Dimensions marked * do not include the height of the shoe lug.

2.2.3 SK850LC [8.25m (27ft-1in) Boom+4.40m (14ft-5in) Long Arm+2.80m³ (3.66cu-yd) Bucket]

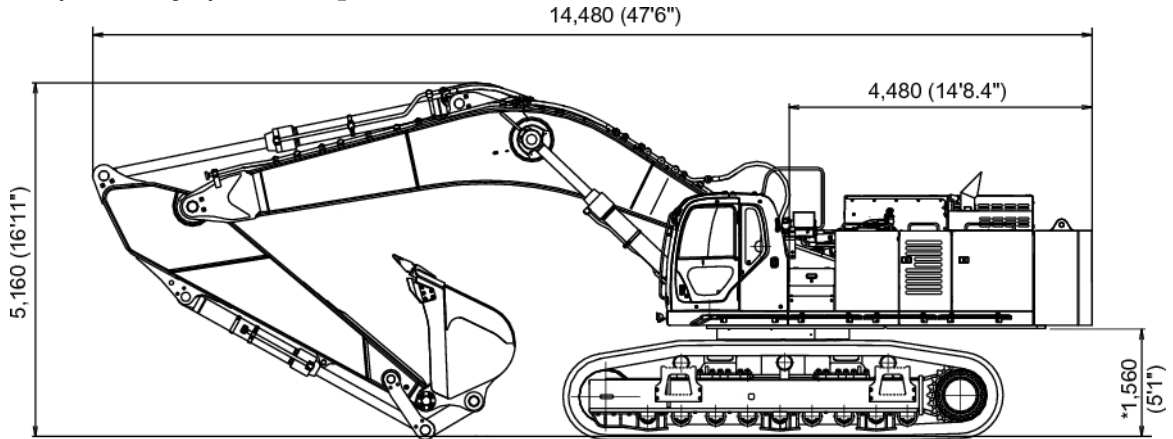

2.2.4 SK850LC [8.25m (27ft-1in) Boom+2.90m (9ft-6in) Short Arm+4.60m³ (6.02cu-yd) Bucket]

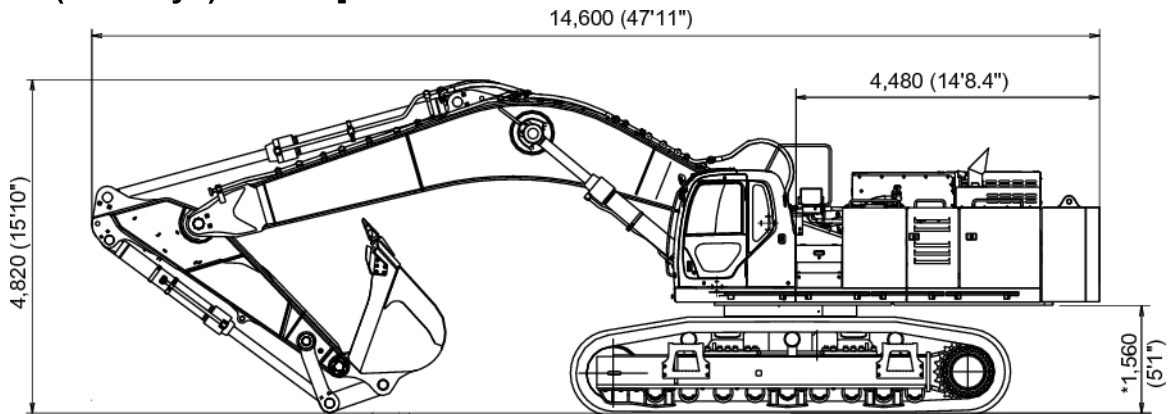

Note

Dimensions marked * do not include the height of the shoe lug.



Suggest:

For more complete manuals. Please go to the home page.

<https://www.ebooklibonline.com>

If the above button click is invalid. Please download this document first, and then click the above link to download the complete manual.

Thank you so much for reading

[2. SPECIFICATIONS]

2.2.5 SK850LC [7.25m (23ft-9in) Boom+2.90m (9ft-6in) Short Arm+4.30m³ (5.62cu-yd) Bucket]

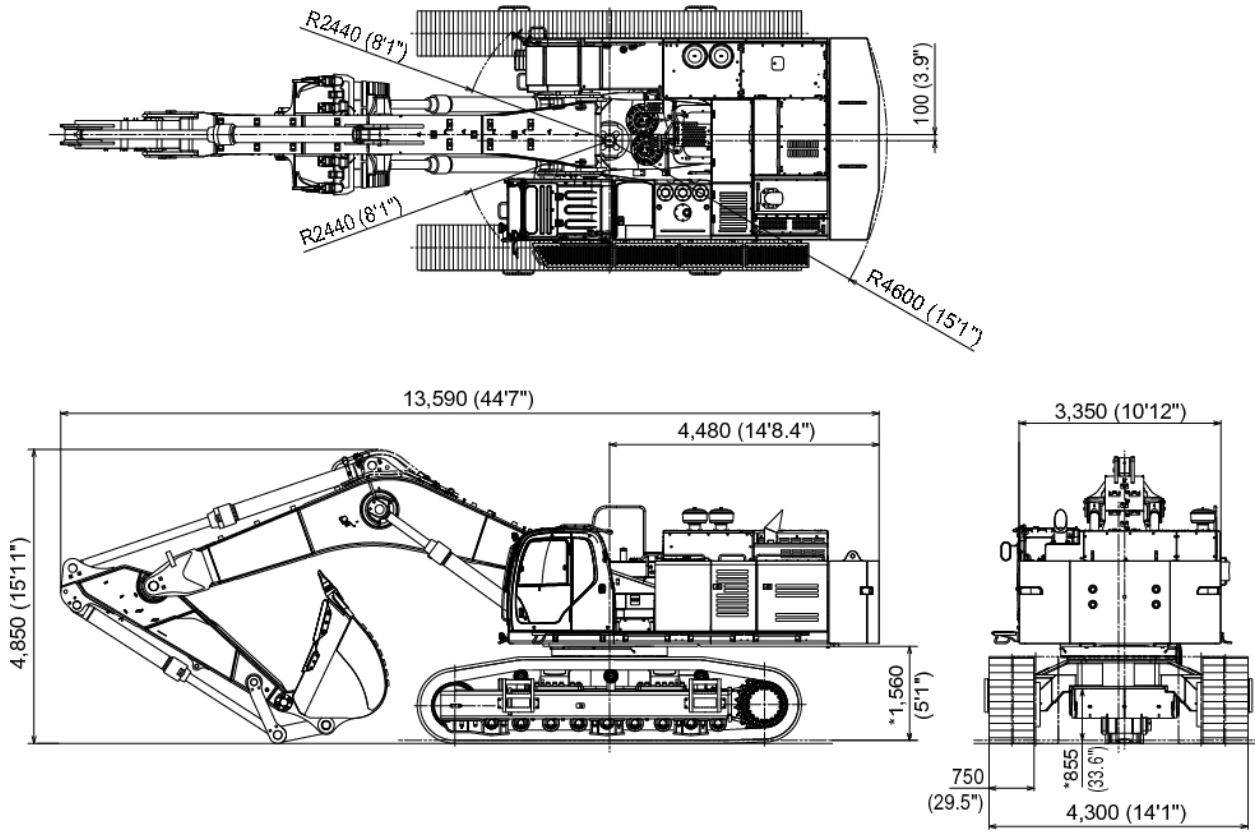

2.3 WEIGHT OF COMPONENTS

Item / Model	SK850LC (STD)	SK850LC (ME)
Machine complete: kg (lb)	78,800 (173,750)	79,300 (174,860)
1. Upper frame assy (Assembly of following :)	29,200 (64,390)	<--
1.1 Upper frame	6,860 (15,130)	<--
1.2 Counter weight		
Counter weight (Semi-weighted)	13,300 (29,330)	<--
1.3 Cab	290 (640)	<--
1.4 Engine	*1,675 (3,693)	<--
1.5 Hydraulic oil tank	*540 (1,191)	<--
1.6 Fuel tank	*410 (904)	<--
1.7 Slewing motor (including reduction unit)	*482 (1,063) X 2	<--
1.8 Control valve	*400 (882)	<--
1.9 Boom cylinder	*870 (1,918) X 2	<--
1.10 Pin (for mounting boom)	260 (573)	<--
1.11 Pump	155 (342) X 2	<--
1.12 Radiator (including intercooler)	*400 (882)	<--
1.13 Oil cooler	*245 (540)	<--
2. Lower frame assy (Assembly of following :)	31,100 (68,580)	<--
2.1 Lower frame	12,100 (26,680)	<--
2.2 Slewing bearing	1,290 (2,844)	<--
2.3 Travel motor (including reduction unit)	*860 (1,896) X 2	<--
2.4 Upper roller	46 (101) X 6	<--
2.5 Lower roller	137 (302) X 18	<--
2.6 Front idler	480 (1,058) X 2	<--
2.7 Idler adjuster	625 (1,378) X 2	<--
2.8 Sprocket	175 (386) X 2	<--
2.9 Swivel joint	*70 (154)	<--
2.10 Track guide	80 (176) X 4	<--
2.11 Track link with 750mm (29.5in) shoes assy	9,075 (20,010) X 2	<--
2.11 Track link with 650mm (25.6in) shoes assy	8,410 (18,544) X 2	<--
2.11 Track link with 900mm (35.4in) shoes assy	10,200 (22,491) X 2	<--
2.11.1 Track link assy	1,900 (4,190) X 2	<--

<https://www.ebooklibonline.com>

Hello dear friend!

Thank you very much for reading.

Enter the link into your browser.

The full manual is available for immediate download.

<https://www.ebooklibonline.com>