

KOBELCO

SHOP MANUAL
HYDRAULIC EXCAVATOR
SK480LC-6

87364108 NA

Issued 07-2006

APPLICABLE:
SK480LC-6 YS06U0101~

Kobelco

SK480LC-6E

Hydraulic Excavator

Service Manual - Part A

Chapter 01 Cycle Times	1-1
Chapter 02 Maintenance Specifications	2-1
Chapter 03 Hydraulic Schematics	3-1
Chapter 04 Pressure Adjustment	4-1
Chapter 05 Mechatronics	5-1
Chapter 06 Electrical Schematics	6-1

Kobelco Construction Machinery America LLC

Contents

CONTENTS

NOTES

<https://www.ebooklibonline.com>

Hello dear friend!

Thank you very much for reading.

Enter the link into your browser.

The full manual is available for immediate download.

<https://www.ebooklibonline.com>

Kobelco

SK480LC-6E

Hydraulic Excavator

Service Manual - Part A

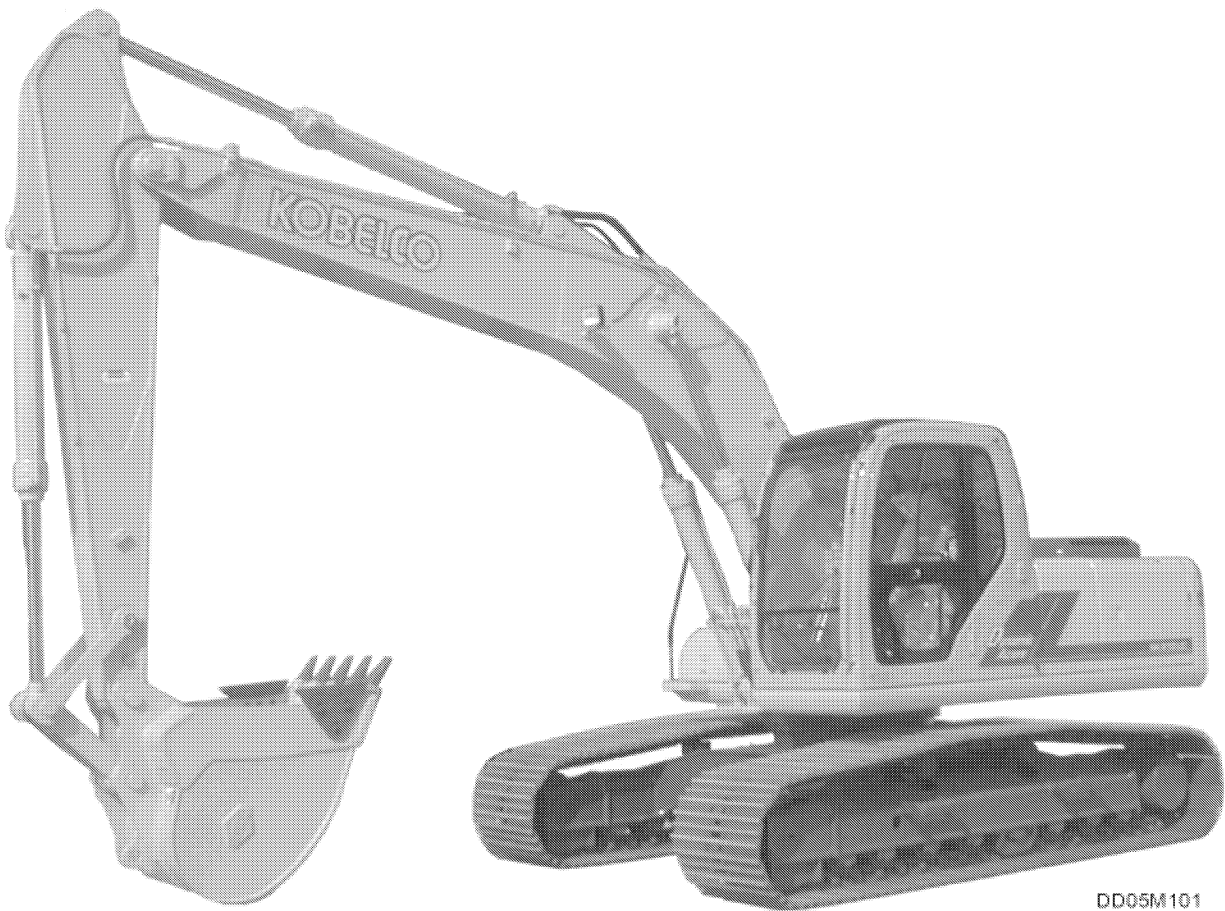

Kobelco Construction Machinery America LLC

Cycle Times

KOBELCO

Kobelco Construction
Machinery America LLC

Table of Contents

PRE-CYCLE TIME CONSIDERATIONS	1-3
A. BUCKET SELECTION GUIDE	1-3
B. USE OF OPTIONAL ATTACHMENTS	1-3
CYLINDER CYCLE TIME TESTS	1-4
A. Tools & Equipment	1-4
B. Machine Settings & Site Conditions	1-4
C. Boom Cylinder Cycle Time Test	1-4
D. Arm Cylinder Cycle Time Test	1-5
E. Bucket Cylinder Cycle Time Test	1-6
SWING SPEED TIME TEST	1-7
A. Tools & Equipment	1-7
B. Machine Settings & Site Condition	1-7
C. Swing Speed Test	1-7
TRAVEL SPEED TIME TEST	1-8
A. Tools & Equipment	1-8
B. Machine Settings & Site Condition	1-8
C. Travel Speed Test	1-8

PRE-CYCLE TIME CONSIDERATIONS

A. BUCKET SELECTION GUIDE

Bucket selection is extremely important to a machine's productivity, durability and stability.

Choosing an excessively large bucket can reduce productivity due to slower than normal cycle times.

Using an oversized or overly wide bucket, in severe conditions, such as mining, will lead to durability problems for both the machine and bucket involved.

Stability will be adversely affected using a bucket that is unnecessarily large.

The Bucket Selection Charts listed in the Specification's Section in the Operator's Manual are to be used as general guidelines.

If the buckets used locally vary in weight from these sample buckets, it will be necessary to adjust the bucket capacity accordingly. A heavier bucket must correspond to a reduced capacity.

If the material density (weight) exceeds guideline specifications then the bucket capacity must be reduced.

If the machine is to continuously dig rock, wasted shale, river cobble or other severe applications the narrowest bucket possible should be utilized. This will allow the greatest possible penetration and minimal twisting of the attachment (boom and stick). Bucket capacity is not to be the prime consideration for severe applications.

If a machine is to exclusively load trucks at close radius then the bucket loads can be adjusted up 5% to 7% from the Lift Chart values listed in the Specification's Section, of the Operator's Manual due to a close in dump radius.

If a machine is to be utilized exclusively to spoil pile, which causes a large radius dump cycle, applicable loads may have to be adjusted down by 5% from the Lift Chart Values or stability complaints may occur.

See the Specification's Section in the Operator's Manual - "Bucket Selection Charts" to select the appropriate bucket size according to the application for the SK210LC.

B. USE OF OPTIONAL ATTACHMENTS

If a machine is equipped with optional attachments such as a bucket quick coupler, and/or thumbs, (either hydraulic or mechanical) applicable bucket sizes and suspended loads must be reduced in direct proportion to the weight or combined weight of these attachments. Failure to consider the added weight of such attachments will cause stability complaints. Additionally these weights of such attachments must be considered when the lift chart is referred to before lifting a load. The additional weight of heavy buckets, couplers, and thumbs, must be deducted from allowable lift capacities.

Use of quick couplers for bucket interchangeability will reduce effective arm digging force and particularly bucket breakout force due to an increase of tooth tip radius.

Example: Some couplers can increase tooth tip radius up to 12 inches. If this is used with a 48" tooth tip radius, effective bucket breakout force can be reduced 25%, a 5% reduction in effective arm force, a reduction in lift capacities of up to 600 lbs. It is, also, important to mention that some quick couplers offer a great advantage, particularly when lifting loads. A good example is the Hendrix JB Quick Coupler. This high strength low profile coupler allows the operator to quickly remove the bucket for lifting purposes; therefore, increasing lifting capacity, height, and visibility.

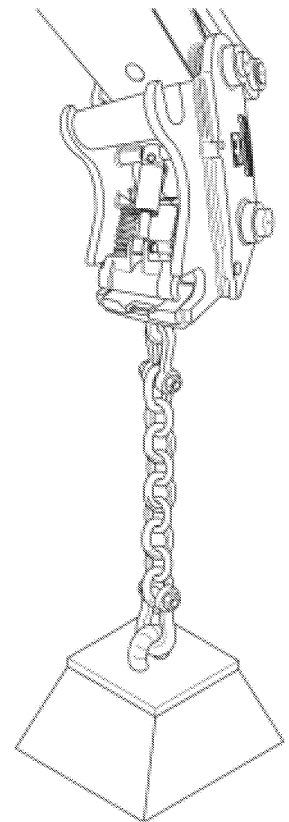

To obtain the proper lifting capacity when a quick coupler is used, proceed as follows: deduct the weight of the standard bucket from the lifting chart, add the weight of the quick coupler plus the weight of the attachment to be coupled. Consideration of the Center of Gravity of the new attachment + coupler may be necessary.

CYLINDER CYCLE TIME TESTS

NOTE

The measuring time of the cylinder cycle does not include the cushion stroke times. Only measure time up to the beginning of the cushion stroke.

A. Tools & Equipment

The following tools and equipment will be required to perform the cylinder cycle time test:

1. Stopwatch.
2. Thermometer or heat gun to read Hydraulic Oil Temperature. Cycle attachment a few times to warm up hydraulic system.

B. Machine Settings & Site Conditions

1. Disable Auto Accel by Pressing Accel button.
2. Place machine throttle in "High" idle position. A/C unit should be turned "OFF".
3. Hydraulic oil temperature at 55°C to 65°C (131°F to 149°F).
4. Firm, level testing site. Check all Fluid levels before testing.
5. Verify that engine RPM's are correct to specifications.

C. Boom Cylinder Cycle Time Test

1. Place the machine throttle control to "HIGH" idle and the KPSS Work Mode Switch to "M" Mode.
2. Fully extend the Bucket Cylinder. See Figure 3.2.
3. Fully retract the Arm Cylinder. See Figure 3.2.
4. Lower Boom until bucket rests on the ground level with bottom of tracks.
5. Raise Boom (extending the cylinders) at full stroke of the control and measure the time for the boom cylinder to reach the cushion stroke. Record the time. See Figure 3.3.
6. Lower the boom (retracting cylinders) at full stroke and measure the time for the bucket to reach ground level. Record the time. See Figure 3.3.
7. Repeat steps 5 and 6 two more times and record the stopwatch readings. Average the readings and compare the average to the Boom Cylinder Cycle Time Specification Chart.

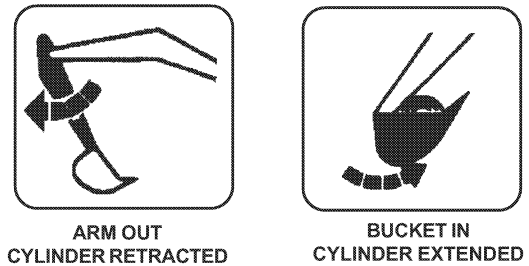

FIGURE 3.2

DO NOT TIME CUSHION STROKE OF CYLINDER DURING TEST

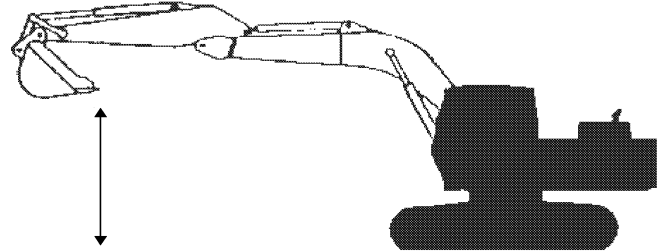



FIGURE 3.3

BOOM CYLINDER CYCLE TIME SPECIFICATIONS

MODEL	CYLINDER POSITION	M-MODE
*SK160	EXTENSION	2.6 - 3.2
*SK160	RETRACTION	2.3 - 2.9
SK210	EXTENSION	2.9 - 3.5
SK210	RETRACTION	2.5 - 3.1
SK250	EXTENSION	2.8 - 3.4
SK250	RETRACTION	2.5 - 3.1
SK290	EXTENSION	2.9 - 3.4
SK290	RETRACTION	2.6 - 3.1
SK330	EXTENSION	3.1 - 3.6
SK330	RETRACTION	2.7 - 3.3
SK480	EXTENSION	3.1 - 3.7
SK480	RETRACTION	2.8 - 3.4

*SK160 and ED190 same

Unit: Seconds

	CAUTION	
<p><i>THIS TEST IS DESIGNED FOR STANDARD BOOM, ARM AND BUCKET. IF THE MACHINE BEING TESTED HAS ANY OPTIONAL EQUIPMENT, CHECK TO MAKE CERTAIN THERE WILL BE NO INTERFERENCE WITH THE CAB BEFORE PERFORMING THE TEST !!</i></p>		

D. Arm Cylinder Cycle Time Test

NOTE

The measuring time of the cylinder cycle does not include the cushion stroke times. Only measure time up to the beginning of the cushion stroke. Cycle attachment a few times to warm up hydraulic system.

1. Move the machine to a firm, level testing area. Check all Fluid levels before testing.
2. Place the machine throttle control to "HIGH" idle and The KPSS Work Mode Switch to "M" Mode.
3. Fully extend Boom Cylinder. See Figure 3.5.
4. Fully retract Bucket Cylinder. See Figure 3.5.
5. Fully extend the Arm (retracting cylinder).
6. At full stroke of the control, bring the arm all the way in (extending cylinder) and measure the time it takes for the arm cylinder to reach the cushion stroke. Record the time. See Figure 3.6.
7. At full stroke of the control, fully extend the arm (retracting cylinder) and measure the time it takes until the cylinder reaches the cushion stroke. Record the time. See Figure 3.6.
8. Repeat steps 6 and 7 two more times. Average the recorded times and compare the average to the Arm Cylinder Cycle Time Specification Chart.

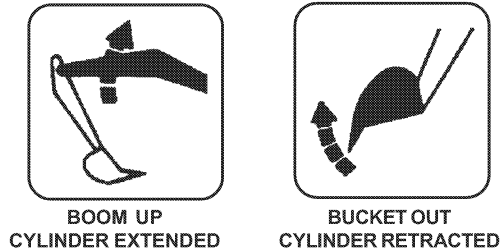

FIGURE 3.5

DO NOT TIME CUSHION STROKE OF CYLINDER DURING TEST

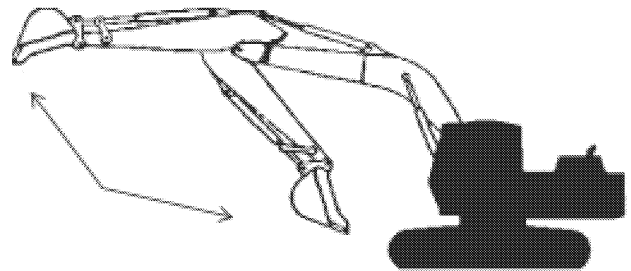

FIGURE 3.6

ARM CYLINDER CYCLE TIME SPECIFICATIONS

MODEL	CYLINDER POSITION	M-MODE
*SK160	EXTENSION	3.1 - 3.7
*SK160	RETRACTION	2.4 - 3.0
SK210	EXTENSION	3.1 - 3.7
SK210	RETRACTION	2.4 - 3.0
SK250	EXTENSION	3.3 - 3.9
SK250	RETRACTION	2.5 - 3.1
SK290	EXTENSION	3.6 - 4.2
SK290	RETRACTION	2.7 - 3.3
SK330	EXTENSION	4.1 - 5.1
SK330	RETRACTION	3.1 - 3.7
SK480	EXTENSION	4.1 - 4.9
SK480	RETRACTION	2.9 - 3.5

*SK160 and ED190 same

Unit: Seconds

E. Bucket Cylinder Cycle Time Test

NOTE

The measuring time of the cylinder cycle does not include the cushion stroke times. Only measure time up to the beginning of the cushion stroke. Cycle attachment a few times to warm up hydraulic system.

1. Move the machine to a firm, level testing area. Check all Fluid levels before testing.
2. Place the machine throttle control to "HIGH" idle and The KPSS Work Mode Switch to "M" Mode.
3. Raise Boom to full height using "Boom Up" control.
4. Adjust the arm until the arm is at 90° to arm cylinder. See Figure 3.8.
5. Lower boom until the arm tip is parallel with the boom foot. See Figure 3.8.
6. Bring bucket all the way in.
7. Operate bucket out (retracting cylinder) at full stroke of control and measure the time it takes for the bucket cylinder to reach the cushion stroke (if equipped). Record the time. See figure 3.9.
8. Operate the bucket in (extending cylinder) at full stroke of control and measure the time it takes for the bucket cylinder to reach the cushion stroke (if equipped). Record the time. See Figure 3.9.
9. Repeat steps 7 and 8 two more times. Average the readings and compare to the Bucket Cylinder Cycle Time Specification Chart.

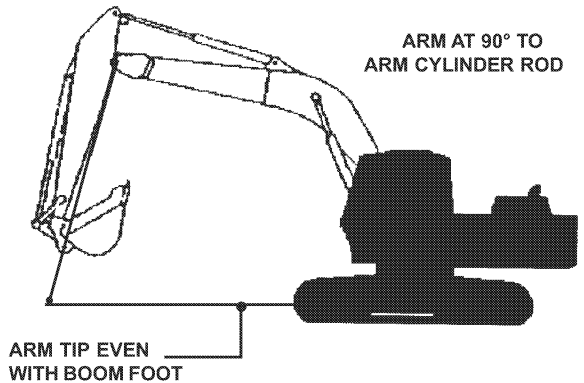

FIGURE 3.8

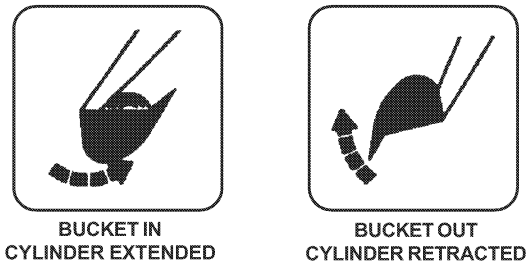

FIGURE 3.9

BUCKET CYLINDER CYCLE TIME SPECIFICATIONS

MODEL	CYLINDER POSITION	M-MODE
*SK160	EXTENSION	3.5 - 4.1
*SK160	RETRACTION	1.9 - 2.5
SK210	EXTENSION	2.3 - 2.9
SK210	RETRACTION	1.7 - 2.3
SK250	EXTENSION	2.4 - 3.0
SK250	RETRACTION	1.8 - 2.4
SK290	EXTENSION	2.6 - 3.2
SK290	RETRACTION	2.3 - 2.9
SK330	EXTENSION	2.7 - 3.3
SK330	RETRACTION	2.1 - 2.7
SK480	EXTENSION	2.7 - 3.3
SK480	RETRACTION	2.1 - 2.7

*SK160 and ED190 same

Unit: Seconds



Suggest:

For more complete manuals. Please go to the home page.

<https://www.ebooklibonline.com>

If the above button click is invalid. Please download this document first, and then click the above link to download the complete manual.

Thank you so much for reading

SWING SPEED TIME TEST

A. Tools & Equipment.

1. Stopwatch
2. Device for Marking Starting Point
3. Measuring Tape

B. Machine Settings & Site Condition

1. Machine throttle in "High" Idle position.
2. Hydraulic oil temperature at 55°C to 65°C (131°F to 149°F).
3. Firm, level testing site.
4. Verify that engine RPM's are to correct specification.

C. Swing Speed Test

1. Move the machine to a firm, level testing area. Check all Fluid levels before testing.

!	WARNING	!
<p>• MAKE CERTAIN THE TEST AREA WILL ALLOW SAFE 360° SWING OF THE MACHINE.</p> <p>• MAKE CERTAIN NO PERSONS OR OTHER EQUIPMENT ARE WITHIN 50 FEET OF THE SWING AREA. PLACE CONES OR SPOTTER IF NEEDED FOR SAFETY.</p>		

2. Move throttle to High Idle and place KPSS switch in "M" mode.
3. Operate the Arm Out Control until arm is completely out (retracting cylinder). See Figure 4.2.
4. Operate the Bucket Out Control until bucket is completely out (retracting cylinder). See Figure 4.1.
5. Adjust boom up or down until bucket teeth are 1.5m (4'-11") from ground level. See Figure 4.2.

!	CAUTION	!
<p>Turn on Swing Flasher and sound horn BEFORE starting swing motion.</p>		

6. After sounding horn and with swing flashers on, operate swing control at full stroke for two complete rotations clockwise. Time the last rotation and record the reading. Bring swing to a complete stop.
7. Repeat steps 3 through 5 two more times and average the readings. Compare the average to the Swing Speed Specification Chart.
8. Repeat steps 2 through 7 swinging counterclockwise.

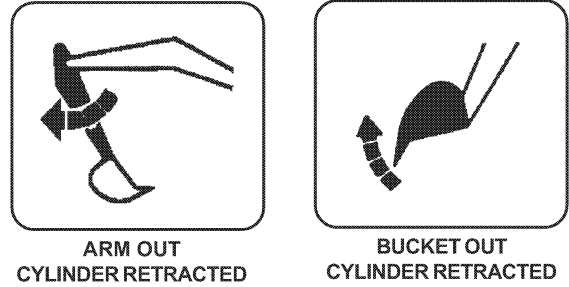

FIGURE 4.1

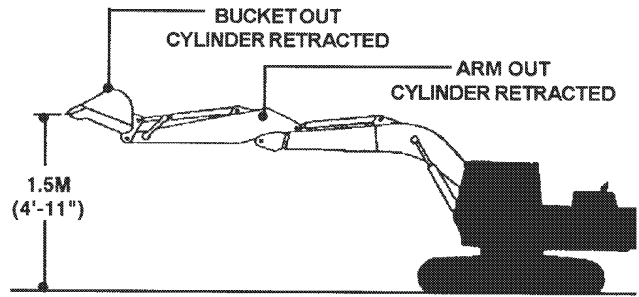

FIGURE 4.2

SWING SPEED SPECIFICATIONS

MODEL	CLOCKWISE / COUNTERCLOCKWISE
*SK160	4.8 - 5.6
*SK160	4.8 - 5.6
SK210	4.9 - 5.3
SK210	4.9 - 5.3
SK250	5.2 - 5.8
SK250	5.2 - 5.8
SK290	5.5 - 6.1
SK290	5.5 - 6.1
SK330	6.4 - 7.0
SK330	6.4 - 7.0
SK480	6.6 - 7.2
SK480	6.6 - 7.2

*SK160 and ED190 same

Unit: Seconds per Revolution

TRAVEL SPEED TIME TEST

A. Tools & Equipment

1. Stopwatch
2. Device to mark starting point of tracks.

B. Machine Settings & Site Condition

1. Machine throttle in "High" idle position.
2. Test will be performed with KPSS Mode Switch in "M".
3. Hydraulic oil temperature at 55°C to 65°C (131°F to 149°F).
4. Firm, level testing area.
5. Verify that engine RPM's are at correct specification.

C. Travel Speed Test

1. Move machine to a firm, level testing area.
2. Allow the hydraulic oil to reach a temperature of 45°C to 55°C (113°F to 131°F).
3. Operate Swing Right Control until machine is sitting across (perpendicular) tracks.
4. Operate the Boom, Arm and Bucket Controls until bucket is on ground. See Figure 7.4.
5. Operate Boom Control until bottom of right track is approximately 300mm (12") off ground. See Figure 7.4. Make reference mark on track.
6. Place Throttle Control in "HI-IDLE" position and KPSS Switch in "M" Mode.
7. Place Travel Speed Select Switch in Low 1() Speed.

8. Operate the Right Travel Control full forward and measure the time it takes for track to make three complete revolutions. Record the time.
9. Repeat Step 7 and 8 two more times. Average the readings and compare to travel Speed Specification Chart.
10. Place Travel Speed Select Switch in High 2() speed and repeat steps 8 and 9.
11. Repeat steps 4 through 13 with Left Track approximately 300mm (12") off ground.

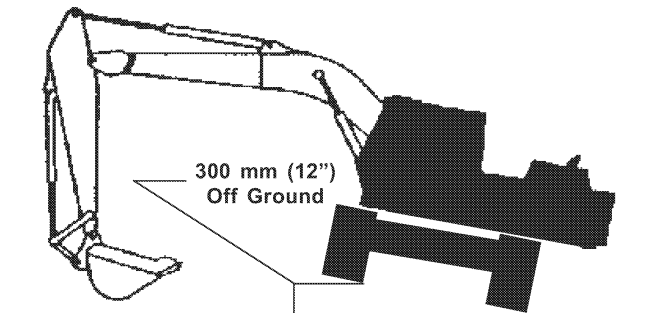

FIGURE 7.4
SK210 - SK400 ILLUSTRATED

<https://www.ebooklibonline.com>

Hello dear friend!

Thank you very much for reading.

Enter the link into your browser.

The full manual is available for immediate download.

<https://www.ebooklibonline.com>