

KOBELCO

SERVICE MANUAL

HYDRAULIC EXCAVATOR

SK270LC IV

APPLICABLE: LBU0001~

APPLICABLE: LBU0201~

S5LBU0005E(PLM)

09/03

KOBELCO

SK270_{LC}

MARK IV

HYDRAULIC EXCAVATOR

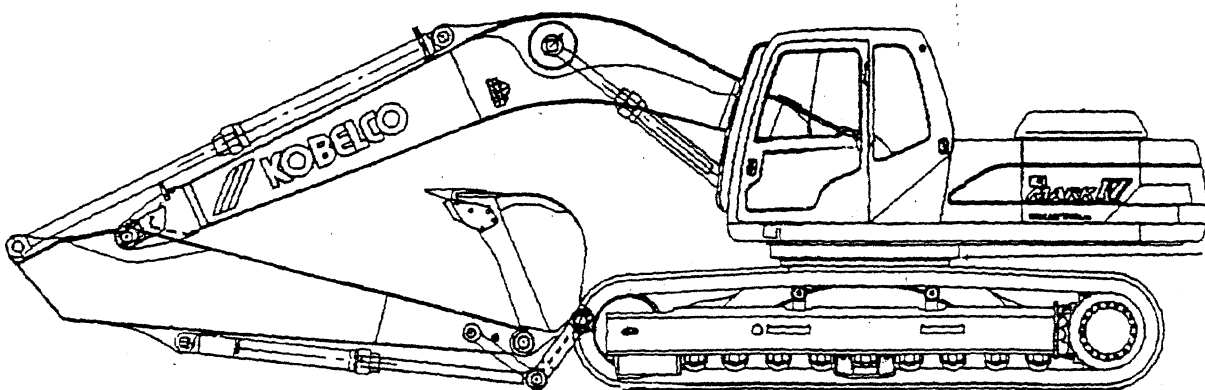

HYDRAULIC EXCAVATOR

MODEL

SK270LC IV

APPLICABLE: LBU0001~

LBU0201~

BOOK CODE NO. S5LBU0005E(PLM)

<https://www.ebooklibonline.com>

Hello dear friend!

Thank you very much for reading.

Enter the link into your browser.

The full manual is available for immediate download.

<https://www.ebooklibonline.com>

SHOP MANUAL

model

LBU LQU · LLU

TABLE OF CONTENTS

1. SPECIFICATION
2. OPERATION AND CONTROLS (Refer to Operators Manual)
3. LOCATION AND WEIGHT OF COMPONENTS
4. MAINTENANCE STANDARDS AND TEST PROCEDURES
5.
6. PREVENTIVE MAINTENANCE (Refer to Operators Manual)
7. WORKING STANDARDS
8. STANDARD MAN-HOUR TABLE

LLU01

LLU03

LLU04

LLU07

LLU08

○How to Index each Shop Manual Section

The GENERAL of this shop manual consists of 8 headings as shown above. Each section can be easily referred to by indexes appended to the margin of the page as indicated on the right. Please use the indexes for speedy reference.

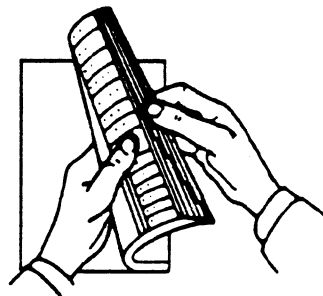

KOBELCO

GENERAL

HYDRAULIC EXCAVATOR

SHOP MANUAL

model

LBU LQU · LLU

This is the shop manual for KOBELCO hydraulic excavator. Contained is the necessary technical data concerning the maintenance and repair of this model. The manual is divided into the following four major sections; GENERAL, SYSTEMS, COMPONENTS and PROCEDURE.

*GENERAL

- LLU01. SPECIFICATION
 - OPERATION AND CONTROLS
(Refer to Operators Manual)
- LLU03. LOCATION AND WEIGHT OF COMPONENTS

- LLU04. MAINTENANCE STANDARD AND TEST PROCEDURE
 - PREVENTIVE MAINTENANCE
(Refer to Operators Manual)
- LLU07. WORKING STANDARD

*SYSTEMS

- LLU12. HYDRAULIC SYSTEM
- LLU15. SWING FRAME
- LLU18. TRAVEL SYSTEM
- LLU21. ATTACHMENTS

- LLU22. CONTROL SYSTEM
- LLU25. ELECTRICAL SYSTEM
- LLU29. TROUBLE SHOOTING

*COMPONENTS

- 12. HYDRAULIC PUMP
- 13. CONTROL VALVE
- 14. OTHER VALVES
- 15. HYDRAULIC MOTOR

- 16. SWIVEL JOINT
- 17. HYDRAULIC CYLINDER
- 21. REDUCTION UNIT
- 50. ENGINE

*PROCEDURE

When checking or repairing the machine we suggest that you refer to this manual carefully. We hope that reference to this manual will help to maintain a high level of working efficiency and reliability. For further details on maintenance and checks refer to the "OPERATORS MANUAL" which has been supplied with the machine.

Although all data was correct at the time of printing, due to continual design changes and improvements, some contents may not conform to the actual machine. Take special care to order parts only after confirming the validity of the part number in the "PARTS MANUAL".

If you notice any explanatory discrepancies, after consulting one of our representatives, please update your manual according to the latest data. However, in the event of any specification changes, we will issue revised edition.

INDEX

KOBELCO

Book code No. S5LBU0005E(PLM)

⚠ WARNING

SAFETY

⚠ WARNING

The proper and safe lubrication and maintenance for this machine, recommended by KOBELCO are outlined in the OPERATION & MAINTENANCE GUIDE for this machine.

Improper performance of lubrication or maintenance procedures is dangerous and could result in injury or death. Read and understand the OPERATION & MAINTENANCE GUIDE before performing any lubrication or maintenance.

The serviceman or mechanic may be unfamiliar with many of the systems on this machine. This makes it important to use caution when performing service work. A knowledge of the system and or components is important before the removal or disassembly of any component.

Because of the size of some of the machine components, the serviceman or mechanic should check the weights noted in this Manual. Use proper lifting procedures when removing any components.

Following is a list of basic precautions that should always be observed.

1. Read and understand all Warning plates and decals on the machine before operating, lubricating or repairing this product.
2. Always wear protective glasses and protective shoes when working around machines. In particular, wear protective glasses when pounding on any part of the machine or its attachments with a hammer or sledge. Use welders gloves, hood/goggles, apron and other protective clothing appropriate to the welding job being performed. Do not wear loose-fitting or torn clothing. Remove all rings from fingers when working on machinery.
3. Disconnect battery and discharge any capacitors before starting to work on machine. Hang "Do Not Operate" tag in the Operator's Compartment.
4. If possible, make all repairs with the machine parked on a level, hard surface. Block machine so it does not roll while working on or under machine.
5. Do not work on any machine that is supported only by lift jacks or a hoist. Always use blocks or jack stands to support the machine before performing any disassembly.

⚠ WARNING

Do not operate this machine unless you have read and understand the instructions in the OPERATOR'S MANUAL. Improper machine operation is dangerous and could result in injury or death.

6. Relieve all pressure in air, oil or water systems before any lines, fittings or related items are disconnected or removed. Always make sure all raised components are blocked correctly and be alert for possible pressure when disconnecting any device from a system that utilizes pressure.
7. Lower the bucket, blade, ripper or other implements to the ground before performing any work on the machine. If this cannot be done, make sure the bucket, blade, ripper or other implement is blocked correctly to prevent it from dropping unexpectedly.
8. Use steps and grab handles when mounting or dismounting a machine. Clean any mud or debris from steps, walkways or work platforms before using. Always face machine when using steps, ladders and walkways. When it is not possible to use the designed access system, provide ladders, scaffolds, or work platforms to perform safe repair operations.
9. To avoid back injury, use a hoist when lifting components which weigh 23 kg (50 lbs) or more. Make sure all chains, hooks, slings, etc., are in good condition and are in the correct capacity. Be sure hooks are positioned correctly. Lifting eyes are not to be side loaded during a lifting operation.
10. To avoid burns, be alert for hot parts on machines which have just been stopped and hot fluids in lines, tubes and compartments.
11. Be careful when removing cover plates. Gradually back off the last two bolts or nuts located at opposite ends of the cover or device and pry cover loose to relieve any spring or other pressure, before removing the last two bolts or nuts completely.
12. Be careful when removing filler caps, breathers and plugs on the machine. Hold a rag over the cap or plug to prevent being sprayed or splashed by liquids under pressure. The danger is even greater if the machine has just been stopped because fluids can be hot.

 **WARNING**

13. Always use tools that are in good condition and be sure you understand how to use them before performing any service work.
 14. Reinstall all fasteners with same part number. Do not use a lesser quality fastener if replacements are necessary.
 15. Repairs which require welding should be performed only with the benefit of the appropriate reference information and by personnel adequately trained and knowledgeable in welding procedures. Determine type of metal being welded and select correct welding procedure and electrodes, rods or wire to provide a weld metal strength equivalent at least to that of parent metal. Always disconnect battery during welding operations to protect sensitive electric equipment.
 16. Do not damage wiring during removal operations. Reinstall the wiring so it is not damaged nor will it be damaged in operation by contacting sharp corners, or by rubbing against some object or hot surface. Do not connect wiring to a line containing fluid.
 17. Be sure all protective devices including guards and shields are properly installed and functioning correctly before starting a repair. If a guard or shield must be removed to perform the repair work, use extra caution.
 18. Loose or damaged fuel, lubricant and hydraulic lines, tubes and hoses can cause fires. Do not bend or strike high pressure lines or install ones which have been bent or damaged. Inspect lines, tubes and hoses carefully. Do not check for leaks with your hands. Pin hole (very small) leaks can result in a high velocity oil stream that will be invisible close to the hose. This oil can penetrate the skin and cause personal injury. Use cardboard or paper to locate pin hole leaks.
 19. Tighten connections to the correct torque. Make sure that all heat shields, clamps and guards are installed correctly to avoid excessive heat, vibration or rubbing against other parts during operation. Shields that protect against oil spray onto hot exhaust components in event of a line, tube or seal failure must be installed correctly.
 20. Do not operate a machine if any rotating part is damaged or contacts any other part during operation. Any high speed rotating component that has been damaged or altered should be checked for balance before reusing.
 21. On track-type machines, be careful when servicing or separating tracks. Chips can fly when removing or installing a track pin. Wear safety glasses and long sleeve shirts. Track can unroll very quickly when separated. Keep away from front and rear of machine. The machine can move unexpectedly when both tracks are disengaged from the sprockets. Block the machine to prevent it from moving.
 22. Caution should be used to avoid breathing dust that may be generated when handling components containing asbestos fibers. If this dust is inhaled, it can be hazardous to your health. Components in KOBELCO products that may contain asbestos fibers are brake pads, brake band and lining assemblies, clutch plates and some gaskets. The asbestos used in these components is usually bound in a resin or sealed in some way. Normal handling is not hazardous as long as airborne dust which contains asbestos is not generated.
- If dust which may contain asbestos is present, there are several common sense guidelines that should be followed.
- a. Never use compressed air for cleaning.
 - b. Avoid brushing or grinding of asbestos containing materials.
 - c. For clean up, use wet methods or a vacuum equipped with a high efficiency particulate air (HEPA) filter.
 - d. Use exhaust ventilation on permanent machining jobs.
 - e. Wear an approved respirator if there is no other way to control the dust.
 - f. Comply with applicable rules and regulations for the work place.
 - g. Follow environmental rules and regulations for disposal of asbestos.
 - h. Avoid areas where asbestos particles may be in the air.

KOBELCO

SHOP MANUAL

Book code No.

S5LLU0105E ①

LBU LQU · LLU

LLU01

SPECIFICATION

TABLE OF CONTENTS

1. LOCATION OF COMPONENTS	1
2. GENERAL DIMENSIONS	2
3. SPECIFICATIONS AND PERFORMANCE	3
4. TYPE OF SHOES	5
5. TYPE AND COMBINATION OF ATTACHMENTS ...	5
6. WORKING RANGES OF ATTACHMENTS	7
7. LIFTING-UP ABILITY DIAGRAM	9
8. ENGINE SPECIFICATIONS	16

KOBELCO CONSTRUCTION MACHINERY(U.S.A.) INC.

Applicable Machines

LQU0101~

LLU1201~

LBU0001~

LBU0201~

Revision	Date of Issue	Remarks
First edition	January, 1995	S5LLU0105E K
First Revision	June, 1997	S5LLU0105E ①

1. LOCATION OF COMPONENTS

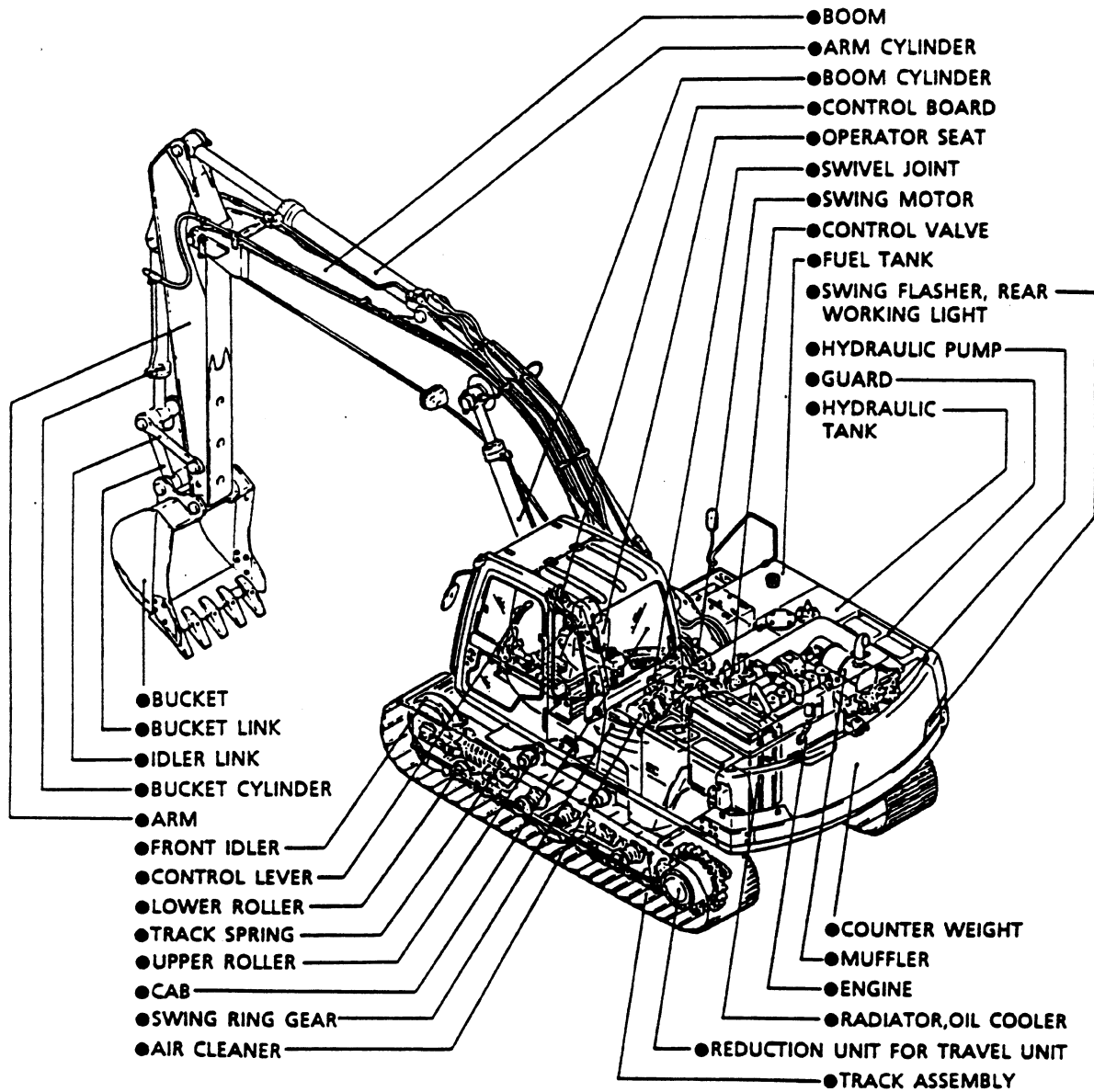

2. GENERAL DIMENSIONS

■ LLU

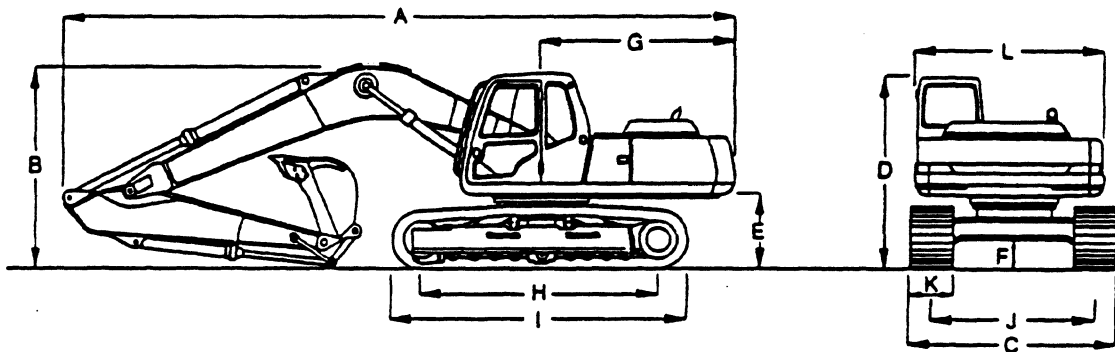
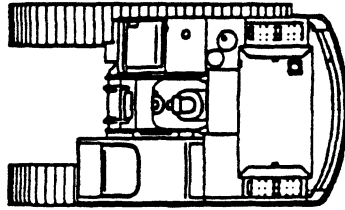

		Unit : m (ft · in)		
Arm length		2.5m (8' 2")	2.98m (9' 9")	3.66m (12' 0")
A	Overall length	10.07 (33' 0")	9.98 (32' 9")	9.98 (32' 9")
B	Overall height (to top of boom)	3.21 (10' 6")	3.07 (10' 1")	3.07 (10' 1")
C	Overall width	3.39 (11' 1")	3.39 (11' 1")	3.39 (11' 1")
D	Overall height (to top of cab)	2.92 (9' 7")	2.92 (9' 7")	2.92 (9' 7")
※E	Ground clearance of rear end	1.08 (3' 7")	1.08 (3' 7")	1.08 (3' 7")
※F	Ground clearance	0.465 (18.3")	0.465 (18.3")	0.465 (18.3")
G	Tall swing radius	2.85 (9' 4")	2.85 (9' 4")	2.85 (9' 4")
H	Tumbler distance	3.80 (12' 6")	3.80 (12' 6")	3.80 (12' 6")
I	Overall length of crawler	4.65 (15' 3")	4.65 (15' 3")	4.65 (15' 3")
J	Track gauge	2.59 (8' 6")	2.59 (8' 6")	2.59 (8' 6")
K	Shoe width	800mm (31.5")	800mm (31.5")	800mm (31.5")
L	Overall width of upper structure	2.83 (9' 3")	2.83 (9' 3")	2.83 (9' 3")

● The figures marks ※ in the illustration do not include the shoe lug (26mm) [1.02"].

■ LQU

		Unit : m (ft · in)		
Arm length		2.5m (8'2")	2.98m (9'9")	3.66m (12'0")
A	Overall length	10.07 (33'0")	9.98 (32'9")	9.98 (32'9")
B	Overall height (to top of boom)	3.21 (10'6")	3.07 (10'1")	3.07 (10'1")
C	Overall width	2.99 (9'10")	2.99 (9'10")	2.99 (9'10")
D	Overall height (to top of cab)	2.92 (9'7")	2.92 (9'7")	2.92 (9'7")
※E	Ground clearance of rear end	1.08 (3'7")	1.08 (3'7")	1.08 (3'7")
※F	Ground clearance	0.465 (18.3")	0.465 (18.3")	0.465 (18.3")
G	Tail swing radius	2.85 (9'4")	2.85 (9'4")	2.85 (9'4")
H	Tumbler distance	3.50 (11'6")	3.50 (11'6")	3.50 (11'6")
I	Overall length of crawler	4.36 (14'4")	4.36 (14'4")	4.36 (14'4")
J	Track gauge	2.39 (7'10")	2.39 (7'10")	2.39 (7'10")
K	Shoe width	600mm (24.0")	600mm (24.0")	600mm (24.0")
L	Overall width of upper structure	2.83 (9'3")	2.83 (9'3")	2.83 (9'3")

● The figures marked ※ in the illustration do not include the shoe lug (26mm) [1.02"].

◆ LBU

		Unit: ft in (m)		
Arm length		8 - 2 (2.5)	9 - 9 (2.98)	11 - 2 (3.4)
A	Overall length	33 - 0 (10.07)	32 - 9 (9.98)	32 - 11 (10.04)
B	Overall height (to top of boom)	10 - 6 (3.21)	10 - 1 (3.07)	10 - 3 (3.13)
C	Overall width	11 - 2 (3.40)	11 - 2 (3.40)	11 - 2 (3.40)
D	Overall height (to top of cab)	9 - 7 (2.92)	9 - 7 (2.92)	9 - 7 (2.92)
E	Ground clearance of rear end*	3 - 7 (1.08)	3 - 7 (1.08)	3 - 7 (1.08)
F	Ground clearance*	18.5 (470)	18.5 (470)	18.5 (470)
G	Tail swing radius	9 - 4 (2.85)	9 - 4 (2.85)	9 - 4 (2.85)
H	Tumbler distance	13 - 2 (4.01)	13 - 2 (4.01)	13 - 2 (4.01)
I	Overall length of crawler	16 - 2 (4.95)	16 - 2 (4.95)	16 - 2 (4.95)
J	Track gauge	8 - 6 (2.60)	8 - 6 (2.60)	8 - 6 (2.60)
K	Shoe width	31.5" (800mm)	31.5" (800mm)	31.5" (800mm)
L	Overall width of upper structure	9 - 3 (2.83)	9 - 3 (2.83)	9 - 3 (2.83)

Note: Figure of astrisk (*) apply to value without shoe lug.

3. SPECIFICATIONS AND PERFORMANCE

■ SPEED AND CLIMBING ABILITY

Item	Model	LQU · LLU
Swing speed		12rpm
Travel speed		7 / 4km / h (4.3 / 2.5 mph)
Gradeability		35° (70%)

■ ENGINE

Model		Cummins 6 BTA5.9	
Type		Water-cooled 4-cycle, direct injection type with exhaust turbo supercharger and after cooling	
Number of cylinder - Bore × Stroke		6 - 102mm(4.02in) × 120mm(4.72in)	
Total displacement		5,880c.c. (359cuin)	
Rated output power/revolution	JISD 1005 NET	※	165 PS/2,200rpm
	SAEJ 1349 NET	※	163 PS/2,200rpm
	DIN 6270 NET	※	165 PS/2,200rpm
Maximum torque/revolution	JISD 1005 NET		60 kgf·m / 1,500rpm
	SAEJ 1349 NET		436 lb·ft / 1,500rpm
	DIN 6270 NET		60 kgf·m / 1,500rpm

Note : Mark ※ indicates that mounted for air cleaner, alternator and no muffler.

■ HYDRAULIC COMPONENTS

Hydraulic pump	Double-pump variable displacement, axial piston + gear pump
Hydraulic motor (swing)	Axial piston motor
Hydraulic motor (travel)	Axial piston motor
Control valve	5-spool multiple control valve + 1-spool control valve (swing)
Cylinders (boom, arm, and bucket)	Double acting cylinder
Return filter	Safety valve containing filter type
Oil cooler	Air-cooled type

■ WEIGHT

Item	Model	LQU			LLU		
Fully-equipped weight		23,900(52,800)	24,260(53,480)	24,600(54,200)	24,700(54,300)	24,940(54,980)	25,300(55,800)
Upper machinery		10,600(23,300)	←	←	←	←	←
Lower machinery with grouser shoe	600 (24')	9,300 (20,500)	←	←	10,100(22,200)	←	←
	700 (28')	←	9,660 (21,300)	←	←	10,340(22,800)	←
	800 (32')	←	←	10,000(22,000)	←	←	10,700(23,700)
6.02m (19' 9") boom + 2.98m (9' 9") arm + 1.04m ³ (1.13 cuyd) bucket		4,000 (8,800)	←	←	←	←	←



Suggest:

For more complete manuals. Please go to the home page.

<https://www.ebooklibonline.com>

If the above button click is invalid. Please download this document first, and then click the above link to download the complete manual.

Thank you so much for reading

4. TYPE OF SHOES

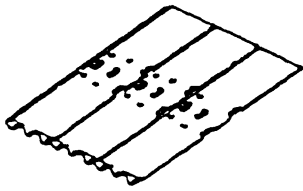
Shape	Model	Width of track shoe (mm(ft-in))	Overall width of crawler (mm(ft-in))	Ground pressure (kg/cm ² (psi))
	LQU	600 (24")	2,800 (9'2")	0.45(6.39)
		700 (28")	2,900 (9'6")	0.39(5.54)
		800 (32")	3,000 (9'10")	0.35(4.96)
	45 link	900 (36")	3,190 (10'6")	0.31(4.40)
		600 (24")	2,990 (9'9")	0.43(6.11)
		700 (28")	3,090 (10'2")	0.36(5.11)
49 link	800 (32")	3,190 (10'6")	0.33(4.69)	

NOTE : • 700mm (28"), 800mm (32") shoe and 900mm (36") shoe come in three types, wet land, paved road and soft land. Do not use these shoes at sites which contain large stones, stamps, or other obstructions.

- Operating machines equipped with special shoes on sites which contain items such as large rocks can bend shoes, cause shoe bolts to loosen, or damage the lower frame (links, rollers, etc.).



OPERATING WEIGHT AND GROUND PRESSURE

SK270LC

In standard trim, with the 11' 2" (3.4 m) arm, and 1.36 cu yd (1.04 m³) SAE/PCSA bucket.

Shape		Triple grouser shoe	
Shoe width	in (mm)	23.5 (600)	31.5 (800)
Overall Width	ft-in (mm)	10 - 6 (3,200)	11 - 2 (3,400)
Ground Pressure	psi (kg/cm ²)	7.69 (0.54)	5.70 (0.4)
Operating Weight	lb (kg)	59,697 (27,079)	61,997 (28,122)

5. TYPES AND COMBINATION OF ATTACHMENTS

■ TYPES OF BUCKETS

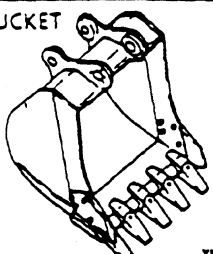
HOE BUCKET	SAE JIS Heaped capacity m ³ (cu yd)	Outside width of bucket mm (ft in)		No. of teeth	Equipped with side cutter	Possibility of turnover	Weight kg (lbs)
		With side cutter	Without side cutter				
	1.40(1.83)	—	1,490 (4'11")	6	No	Yes	900(1,980)
	1.16(1.52)	1,390 (4'7")	1,290 (4'3")	5	Yes	Yes	830(1,830)
	1.04(1.36)	1,280 (4'2")	1,180 (3'10")	4	Yes	Yes	770(1,700)
	0.81(1.06)	1,060 (3'6")	950 (3'1")	4	Yes	Yes	690(1,520)
	*1.04(1.37)	—	1,170 (3'10")	5	No	Yes	890(1,960)
	—	—	—	—	—	—	—

* mark indicates one for heavy digging work.

■ COMBINATIONS OF ATTACHMENTS

Type	Bucket		Applicable arm		
	SAE-JIS heaped capacity m ³ (cuyd)	JIS-SAE struck capacity m ³ (cuyd)	2.5m (8ft-2in) arm	2.98m (9ft-9in) arm	3.66m (12ft) arm
Hoe bucket	0.81 (1.06)	0.59 (0.81)	○	○	●
	1.04 (1.37)	0.76 (0.99)	○	●	△
	* 1.04 (1.37)	0.76 (0.99)	○	○	×
	1.16 (1.52)	0.84 (1.10)	●	△	×
	1.40 (1.83)	1.00 (1.31)	△	×	×
* Mark indicates one for heavy digging work	—	—	—	—	—
Slope finishing bucket	Width × depth 2.2m × 1.2m (7ft-3in × 3ft-11in)	—	△	△	
Ripper	—	—	○	○	×
Ripper bucket	0.67 (0.88)	0.53 (0.69)	○	○	×

NOTE : ● Standard combinations

- General operation : Digging and loading of sand, gravels and clay-mixed soil
- △ Light operation : Operations mainly consisting of loading of loose sand and soil (for instance, operations in paddy fields and loading of sand and gravels)
- × Not usable : Do not operate in such combinations as guarantee does not cover them.

⚠ CAUTION

- If a bucket other than a hoe bucket is used to execute face shovel operation, it will cause damage to the arm and the bucket.
- The combinations other than those mentioned in the above table cannot be used in principle. For further details, contact KOBELCO.

■
L
B
U

Bucket Duty	Capacity (SAE) Cubic Yard (meter)		Width Inches (m)		Bucket Weight lbs.	Arms		
						8'2"	9'9"	11'2"
General Purpose	.875	(.668)	24	(.609)	1560	H	H	H
	1.125	(.860)	30	(.762)	1710	H	H	H
	1.375	(1.051)	36	(.914)	1860	H	H	H
	1.625	(1.242)	42	(1.066)	2060	H	H	M
	1.875	(1.433)	48	(1.219)	2175	H	M	L
2.0	(1.529)	54	(1.37)	2525	M	X	X	
Heavy Duty	1.125	(.960)	30	(.761)	1840	H	H	H
	1.375	(1.051)	36	(.914)	2000	H	H	H
	1.625	(1.242)	42	(1.066)	2215	H	M	M
	1.875	(1.433)	48	(1.219)	2335	M	L	L
Severe Duty	.75	(.573)	27	(.685)	2205	H	H	H
	1.0	(.704)	30	(.762)	2450	H	M	M
	1.125	(.860)	36	(.914)	2545	M	L	L
	1.375	(1.051)	42	(1.066)	2795	L	X	X

- H - Used with material weight up to 3,000 lbs per cubic yard.
- M - Used with material weight up to 2,500 lbs per cubic yard.
- L - Used with material weight up to 2,000 lbs per cubic yard.
- X - Not recommended.

<https://www.ebooklibonline.com>

Hello dear friend!

Thank you very much for reading.

Enter the link into your browser.

The full manual is available for immediate download.

<https://www.ebooklibonline.com>