

KOBELCO

SHOP MANUAL

HYDRAULIC EXCAVATOR

SK220

SK220LC

Applicable: SK220 LQU-00001~
Applicable: SK220LC LLU-00601~

S5LLU0003E

07/03

WARNING

SAFETY

WARNING

The proper and safe lubrication and maintenance for this machine, recommended by KOBELCO are outlined in the OPERATION & MAINTENANCE GUIDE for this machine.

Improper performance of lubrication or maintenance procedures is dangerous and could result in injury or death. Read and understand the OPERATION & MAINTENANCE GUIDE before performing any lubrication or maintenance.

The serviceman or mechanic may be unfamiliar with many of the systems on this machine. This makes it important to use caution when performing service work. A knowledge of the system and or components is important before the removal or disassembly of any component.

Because of the size of some of the machine components, the serviceman or mechanic should check the weights noted in this Manual. Use proper lifting procedures when removing any components.

Following is a list of basic precautions that should always be observed.

1. Read and understand all Warning plates and decals on the machine before operating, lubricating or repairing this product.
2. Always wear protective glasses and protective shoes when working around machines. In particular, wear protective glasses when pounding on any part of the machine or its attachments with a hammer or sledge. Use welders gloves, hood/goggles, apron and other protective clothing appropriate to the welding job being performed. Do not wear loose-fitting or torn clothing. Remove all rings from fingers when working on machinery.
3. Disconnect battery and discharge any capacitors before starting to work on machine. Hang "Do Not Operate" tag in the Operator's Compartment.
4. If possible, make all repairs with the machine parked on a level, hard surface. Block machine so it does not roll while working on or under machine.
5. Do not work on any machine that is supported only by lift jacks or a hoist. Always use blocks or jack stands to support the machine before performing any disassembly.

WARNING

Do not operate this machine unless you have read and understand the instructions in the OPERATOR'S MANUAL. Improper machine operation is dangerous and could result in injury or death.

6. Relieve all pressure in air, oil or water systems before any lines, fittings or related items are disconnected or removed. Always make sure all raised components are blocked correctly and be alert for possible pressure when disconnecting any device from a system that utilizes pressure.
7. Lower the bucket, blade, ripper or other implements to the ground before performing any work on the machine. If this cannot be done, make sure the bucket, blade, ripper or other implement is blocked correctly to prevent it from dropping unexpectedly.
8. Use steps and grab handles when mounting or dismounting a machine. Clean any mud or debris from steps, walkways or work platforms before using. Always face machine when using steps, ladders and walkways. When it is not possible to use the designed access system, provide ladders, scaffolds, or work platforms to perform safe repair operations.
9. To avoid back injury, use a hoist when lifting components which weigh 23 kg (50 lbs) or more. Make sure all chains, hooks, slings, etc., are in good condition and are in the correct capacity. Be sure hooks are positioned correctly. Lifting eyes are not to be side loaded during a lifting operation.
10. To avoid burns, be alert for hot parts on machines which have just been stopped and hot fluids in lines, tubes and compartments.
11. Be careful when removing cover plates. Gradually back off the last two bolts or nuts located at opposite ends of the cover or device and pry cover loose to relieve any spring or other pressure, before removing the last two bolts or nuts completely.
12. Be careful when removing filler caps, breathers and plugs on the machine. Hold a rag over the cap or plug to prevent being sprayed or splashed by liquids under pressure. The danger is even greater if the machine has just been stopped because fluids can be hot.

 **WARNING**

13. Always use tools that are in good condition and be sure you understand how to use them before performing any service work.
 14. Reinstall all fasteners with same part number. Do not use a lesser quality fastener if replacements are necessary.
 15. Repairs which require welding should be performed only with the benefit of the appropriate reference information and by personnel adequately trained and knowledgeable in welding procedures. Make reference to "Techniques of Structural Repair Course". Determine type of metal being welded and select correct welding procedure and electrodes, rods or wire to provide a weld metal strength equivalent at least to that of parent metal.
 16. Do not damage wiring during removal operations. Reinstall the wiring so it is not damaged nor will it be damaged in operation by contacting sharp corners, or by rubbing against some object or hot surface. Do not connect wiring to a line containing fluid.
 17. Be sure all protective devices including guards and shields are properly installed and functioning correctly before starting a repair. If a guard or shield must be removed to perform the repair work, use extra caution.
 18. Always use lift arm supports to keep bucket arms raised and bucket tilted down when maintenance or repair work is performed which requires the bucket in the raised position.
 19. Loose or damaged fuel, lubricant and hydraulic lines, tubes and hoses can cause fires. Do not bend or strike high pressure lines or install ones which have been bent or damaged. Inspect lines, tubes and hoses carefully. Do not check for leaks with your hands. Pin hole (very small) leaks can result in a high velocity oil stream that will be invisible close to the hose. This oil can penetrate the skin and cause personal injury. Use cardboard or paper to locate pin hole leaks.
 20. Tighten connections to the correct torque. Make sure that all heat shields, clamps and guards are installed correctly to avoid excessive heat, vibration or rubbing against other parts during operation. Shields that protect against oil spray onto hot exhaust components in event of a line, tube or seal failure must be installed correctly.
 21. Do not operate a machine if any rotating part is damaged or contacts any other part during operation. Any high speed rotating component that has been damaged or altered should be checked for balance before reusing.
 22. On track-type machines, be careful when servicing or separating tracks. Chips can fly when removing or installing a track pin. Wear safety glasses. Track can unroll very quickly when separated. Keep away from front and rear of machine. The machine can move unexpectedly when both tracks are disengaged from the sprockets. Block the machine to prevent it from moving.
 23. Caution should be used to avoid breathing dust that may be generated when handling components containing asbestos fibers. If this dust is inhaled, it can be hazardous to your health. Components in KOBELCO products that may contain asbestos fibers are brake pads, brake band and lining assemblies, clutch plates and some gaskets. The asbestos used in these components is usually bound in a resin or sealed in some way. Normal handling is not hazardous as long as airborne dust which contains asbestos is not generated.
- If dust which may contain asbestos is present, there are several common sense guidelines that should be followed.
- a. Never use compressed air for cleaning.
 - b. Avoid brushing or grinding of asbestos containing materials.
 - c. For clean up, use wet methods or a vacuum equipped with a high efficiency particulate air (HEPA) filter.
 - d. Use exhaust ventilation on permanent machining jobs.
 - e. Wear an approved respirator if there is no other way to control the dust.
 - f. Comply with applicable rules and regulations for the work place.
 - g. Follow environmental rules and regulations for disposal of asbestos.
 - h. Avoid areas where asbestos particles may be in the air.

<https://www.ebooklibonline.com>

Hello dear friend!

Thank you very much for reading.

Enter the link into your browser.

The full manual is available for immediate download.

<https://www.ebooklibonline.com>

SHOP MANUAL

model

SK 220 SK 220LC

TABLE OF CONTENTS

1. SPECIFICATION	LLU01
2. OPERATION AND CONTROLS (Refer to Operators Manual)	
3. LOCATION AND WEIGHT OF COMPONENTS	LLU03
4. MAINTENANCE STANDARDS AND TEST PROCEDURES	LLU04
5. TROUBLESHOOTING	LLU05
6. PREVENTIVE MAINTENANCE (Refer to Operators Manual)	
7. WORKING STANDARDS	LLU07

○How to Index each Shop Manual Section
The GENERAL of this shop manual consists of 7 headings as shown above. Each section can be easily referred to by indexes appended to the margin of the page as indicated on the right. Please use the indexes for speedy reference.

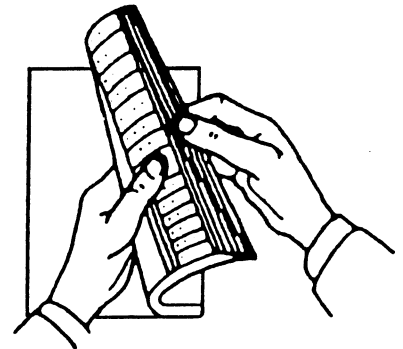

KOBELCO

GENERAL

KOBELCO

Book code No. S5LLU0103E①

SHOP MANUAL

SK 220 SK 220LC

LLU01

SPECIFICATION

TABLE OF CONTENTS

1. LOCATION OF COMPONENTS	1
2. GENERAL DIMENSIONS	2
3. SPECIFICATIONS AND PERFORMANCE	3
4. TYPE OF SHOES	5
5. TYPE AND COMBINATION OF ATTACHMENTS	5
6. WORKING RANGES OF ATTACHMENTS	7
7. LIFTING-UP ABILITY DIAGRAM	9
8. ENGINE SPECIFICATIONS	15

KOBELCO CONSTRUCTION MACHINERY(U.S.A.) INC.

Applicable Machines

LQU-00001~

LLU-00601~

Revision	Date of Issue	Remarks
First edition	October, 1990	S5LLU0103E K
First revision	March, 1992	S5LLU0103E① K

1. LOCATION OF COMPONENTS

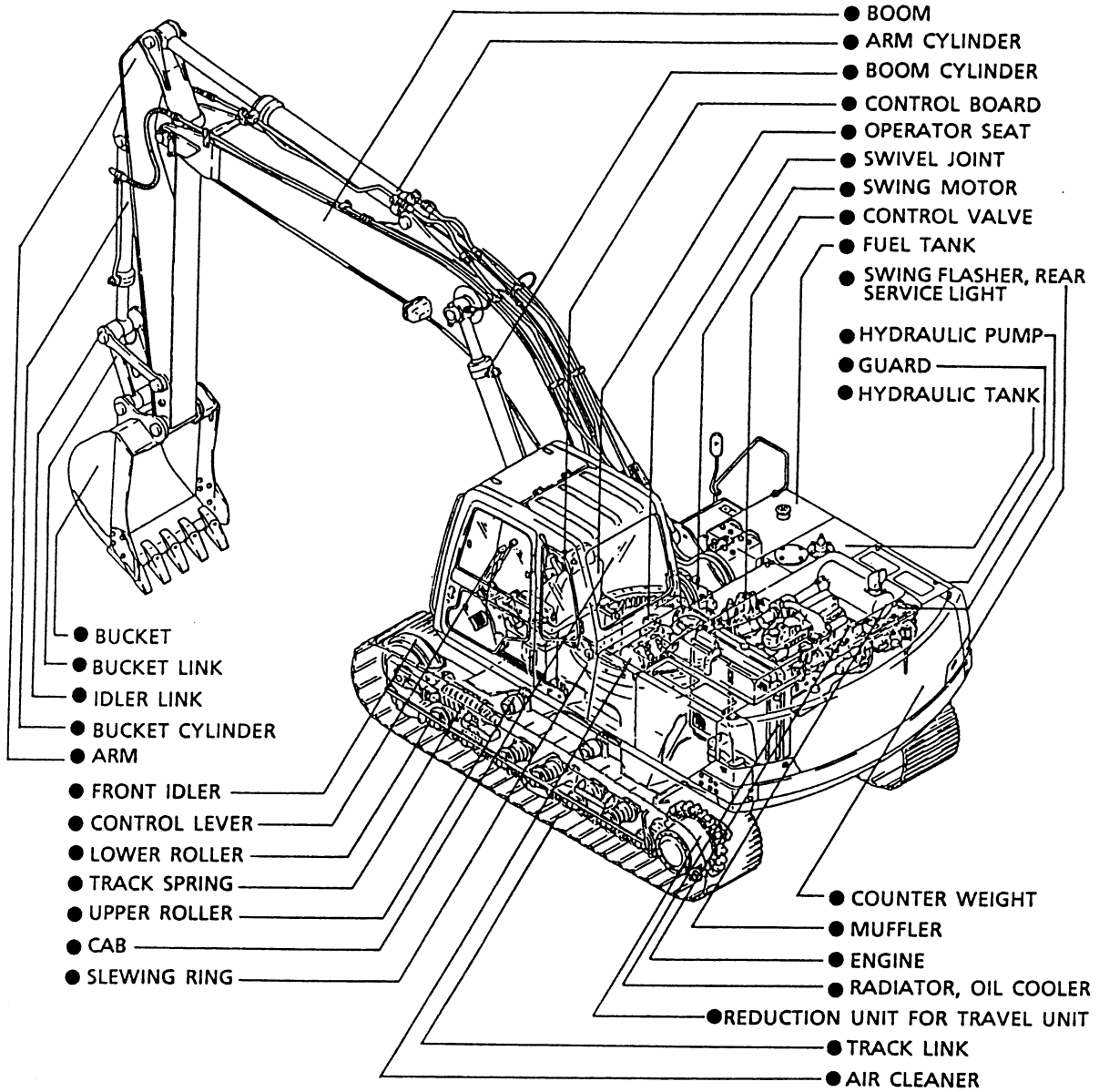

2. GENERAL DIMENSIONS

■ SK220 (6.02m (19ft 9in) BOOM + 2.98m (9ft 9in) ARM-ATTACHED STANDARD MACHINE)

Unit : mm [ft-in]

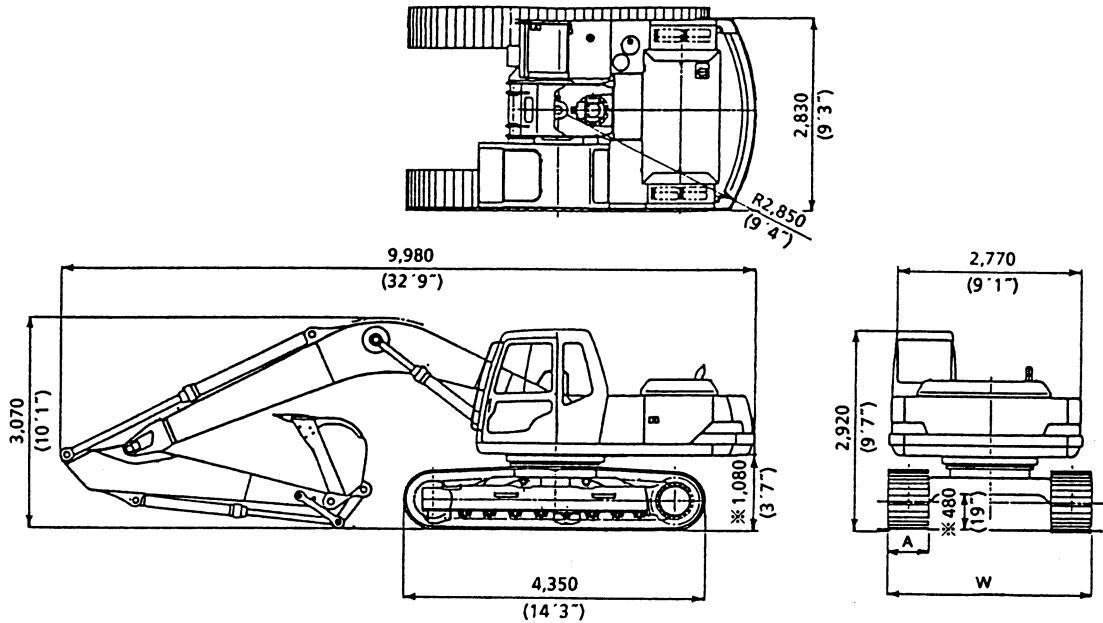

■ SK200Lc (6.02m (19ft 9in) BOOM + 2.98m (9ft 9in) ARM-ATTACHED STANDARD MACHINE)

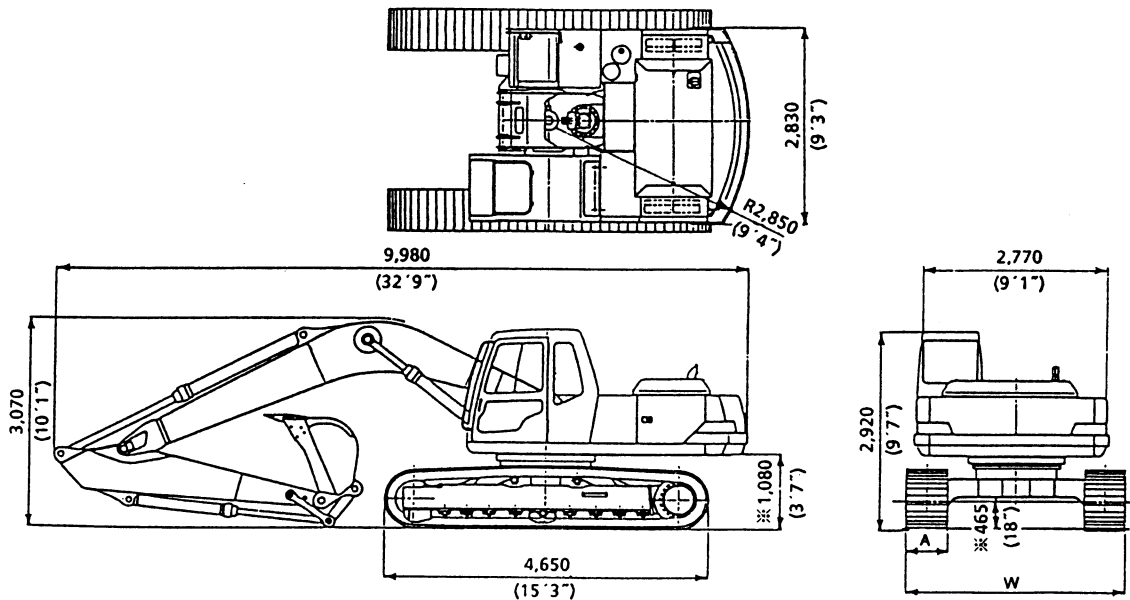

☞ The figures marked * in the illustration do not include the shoe embossment (26mm) (1.02").

■ SK220 (WITH 6.02m (19ft 9in) BOOM + 2.5m (8ft 2in) ARM)

Unit : mm (ft-in)

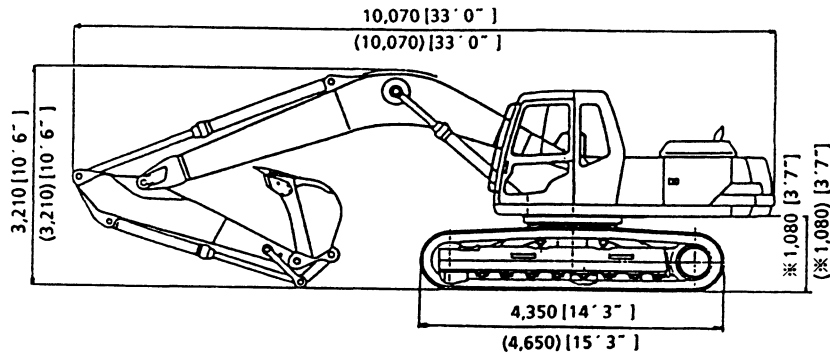

■ SK220 (WITH 6.02m (19ft 9in) BOOM + 3.66m (12ft) ARM)

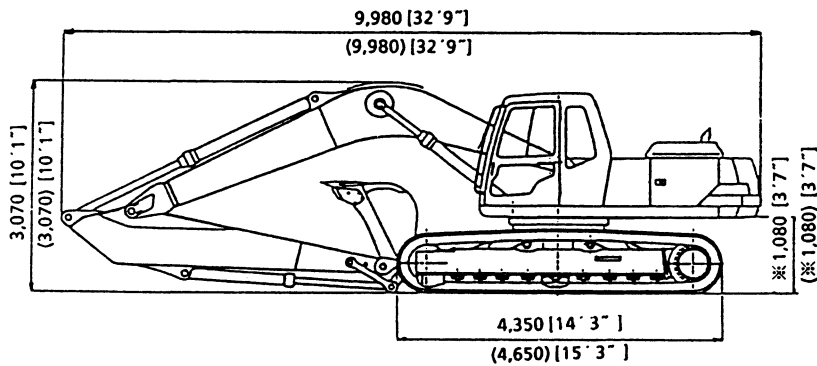

- ☞ The figures marked ※ in the illustration do not include the shoe embossment (26mm) (1.02").
- SK220LC has the dimensions given in parentheses [].

■ Overall width of crawler and width of track shoe

○ Standard
△ Option

	A	W	AMERICA				EUROPA							
	Width of track shoe mm (in)	Overall width of crawler mm (in)	CANADA	KAI	COLOMBIA	CHILE	U.K.	NETH	BELGIUM	PORTUGAL	GERMANY	FRANCE	AUSTRIA	SWITZERLAND
SK220	600 (24")	2,990 (9'10")			○	○				○			○	○
	700 (28")	3,090 (10'2")					○	△	○	△				
	800 (32")	3,190 (10'6")						○	△					
SK220LC	600 (24")	3,190 (10'6")			○	○				○			○	○
	700 (28")	3,290 (10'9")					○	△	○	△				
	800 (32")	3,390 (11'1")	○	○				○	△					

3. SPECIFICATIONS AND PERFORMANCE

■ SPEED AND CLIMBING ABILITY

Item \ Model	SK220	SK220Lc
Swing speed	12rpm	
Travel speed	7/4km/h (4.3/2.5 MPH)	
Gradeability	35° (70%)	

■ ENGINE

Model	Mitsubishi 6 D15T	
Type	Water-cooled 4-cycle, direct injection type with exhaust turbo supercharger	
Number of cylinder - Bore x Stroke	6 - 113mm(4.45in) x 115mm(4.53in)	
Total displacement	6,919c.c. (422cuin)	
Rated output power/revolution	JISD1005 Net	165ps/2,150rpm
	SAEJ1345 Net	121kw/2,150rpm
	DIN 6270 Net	121kw/2,150rpm
Maximum torque/revolution	JISD1005 Net	60kgf-m / 1,600rpm
	SAEJ1349 Net	588N-m / 1,600rpm
	DIN 6270 Net	60kgf-m / 1,600rpm

■ HYDRAULIC COMPONENTS

Hydraulic pump	Double-pump variable displacement, axial piston + gear pump
Hydraulic motor (swing)	Axial piston motor
Hydraulic motor (travel)	Axial piston motor
Control valve	5-section multiple control valve + 1-section control valve (swing)
Cylinders (boom, arm, and bucket)	Double acting cylinder
Return filter	Safety valve containing filter type
Oil cooler	Air-cooled type

■ WEIGHT

Unit : kg (lbs)

Item \ Model	SK220			SK220Lc		
	Model	SK220	SK220	SK220Lc	SK220Lc	SK220Lc
Fully-equipped weight	22,900(50,500)	23,280(51,300)	23,740(52,300)	23,500(51,800)	24,050(53,020)	24,390(53,870)
Upper machinery	9,980(22,000)	←	←	←	←	←
Lower machinery with grouser shoe	600 (24")	8,860(19,500)	←	←	9,460(20,900)	←
	700 (28")	←	9,240(20,400)	←	←	10,010(22,100)
	800 (32")	←	←	9,700(21,400)	←	←
6.02m(19'9") boom + 2.98m (9'9") arm + 0.9m ³ (1.18cuyd) bucket	4,070(8,970)	←	←	←	←	←

4. TYPE OF SHOES

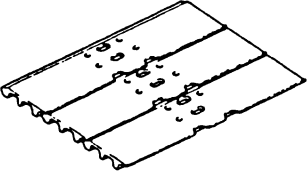
Shape	Model	Width of track shoe (mm (ft-in))	Overall width of crawler (mm (ft-in))	Ground contact Pressure kg/cm ² (psi)		
				STD Arm 2.98M (9' 8")	2.5 M Arm (8' 2")	3.66 M Arm (12' 0")
 Grouser(equal height)	SK220 45 link	600 (24")	2,990 (9' 9")	0.51 (7.25)	0.51 (7.25)	0.51 (7.25)
		700 (28")	3,090 (10' 2")	0.44 (6.26)	0.44 (6.26)	0.45 (6.40)
		800 (32")	3,190 (10' 6")	0.39 (5.55)	0.39 (5.55)	0.40 (5.69)
	SK220Lc 48 link	600 (24")	3,190 (10' 6")	0.48 (6.83)	0.48 (6.83)	0.49 (6.97)
		700 (28")	3,290 (10' 9")	0.41 (5.83)	0.41 (5.83)	0.42 (5.97)
		800 (32")	3,390 (11' 1")	0.37 (5.26)	0.37 (5.26)	0.38 (5.40)

- 700mm (28") shoes and 800mm (32") shoes come in three types, wet land, paved road and soft land. Do not use them at sites with many stones and gravels in any circumstances.
- Note that if you operate such shoe-mounted machines in general civil construction work and in a dry riverbed, it will cause shoes to bend, bring about slackening of shoe bolts and damage to under frame parts (links, roller, etc.).

5. TYPES OF COMBINATIONS AND ATTACHMENTS

■ TYPES OF BUCKETS

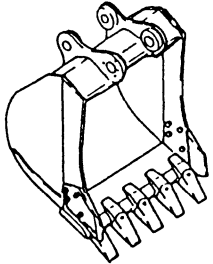
HOE BUCKET	Heaped capacity m ³ (cuyd)	Outside width of bucket mm (ft in)		No. of teeth	Presence or not of side cutter	Possibility of turnover	Weight kg (lbs)
		With side cutter	Without side cutter				
	1.2(1.57)	—	1,490(4' 11")	6	No	Yes	900(1,980)
	1.0(1.31)	1,390(4' 7")	1,290(4' 3")	5	Yes	Yes	830(1,830)
	0.9(1.18)	1,280(4' 2")	1,180(3' 10")	4	Yes	Yes	770(1,700)
	0.7(0.92)	1,060(3' 6")	950(3' 1")	4	Yes	Yes	690(1,520)
	※ 0.9(1.18)	—	1,170(3' 10")	5	No	Yes	890(1,960)

※ mark indicates one for heavy digging work.

RIPPER
Capacity: 0.6 m³ (0.78cuyd)
Weight: 1,020kg (2,250 lbs)
Turnover not possible.

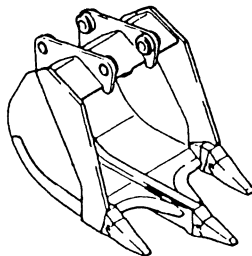

SLOPE FINISHING BUCKET
Weight: 1,050kg (2,300 lbs)
Turnover not possible.

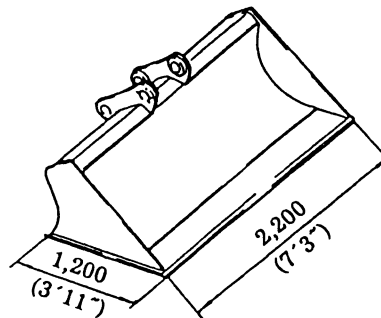

■ COMBINATIONS OF ATTACHMENTS

Type	Bucket			Applicable arm		
	JIS heaped capacity m ³ (cuyd)	SAE heaped capacity m ³ (cuyd)	JIS-SAE struck capacity m ³ (cuyd)	2.5m (8ft2in) arm	2.98m (9ft9in) arm	3.66m (12ft) arm
Hoe bucket	0.7 (0.92)	0.81 (1.06)	0.59 (0.81)	○	○	◎
	0.9 (1.18)	1.04 (1.37)	0.76 (0.98)	○	◎	△
	※ 0.9 (1.18)	1.04 (1.37)	0.76 (0.98)	○	○	×
	1.0 (1.31)	1.16 (1.52)	0.84 (1.09)	◎	△	×
	1.2 (1.57)	1.4 (1.83)	1.0 (1.31)	△	×	×
Slope finishing bucket	0.6 (0.99)	—	—	△	△	
Ripper	—	—	—	○	○	×
Ripper bucket	0.6 (0.78)	0.67 (0.88)	0.53 (0.69)	○	○	×

☞ ◎ Standard combinations

- General operation : Digging and loading of sand, gravels and clay-mixed soil
- △ Light operation : Operations mainly consisting of loading of loose sand and soil (for instance, operations in paddy fields and loading of sand and gravels)
- × Not usable : Do not operate in such combinations as guarantee does not cover them.

- ⚠ ● If a bucket other than hoe buckets is used to execute turnover operation, it will cause damage to the arm and the bucket.
- When the machine is fitted with a 3.66m (12ft) arm (long arm) or an extension arm, do not use the attachment hydraulic circuit for the boost pressure attachment circuit.
- The combinations other than those mentioned in the above table can not be used in principle. For details, contact us.

■ DIGGING FORCE

Arm	+	Bucket	Digging force		ton (UK ton)
			Arm	Bucket	
2.5M (8'2"	+	1.0M ³ 1.3cuyd)	12.9/13.8 (12.7/13.6)		13.8/14.7 (13.6/14.5)
2.98M (9'9"	+	0.9M ³ 1.5cuyd)	10.9/11.6 (10.7/11.4)		13.8/14.7 (13.6/14.5)
3.66M (12'0"	+	0.7M ³ 0.91cuyd)	9.5	(9.3)	13.8 (13.6)



Book code No. S5LLU03_{03E}

SHOP MANUAL

SK 220_{LC}

LOCATION AND WEIGHT OF COMPONENTS

TABLE OF CONTENTS

LLU03

1. LOCATION OF COMPONENTS	1
2. WEIGHT OF COMPONENTS	2
3. TRANSPORTATION WEIGHT	3

Applicable Machines
LLU-00301~

Revision	Date of Issue	Remarks
First edition	October, 1990	S5LLU0303E K

1. LOCATION OF COMPONENTS

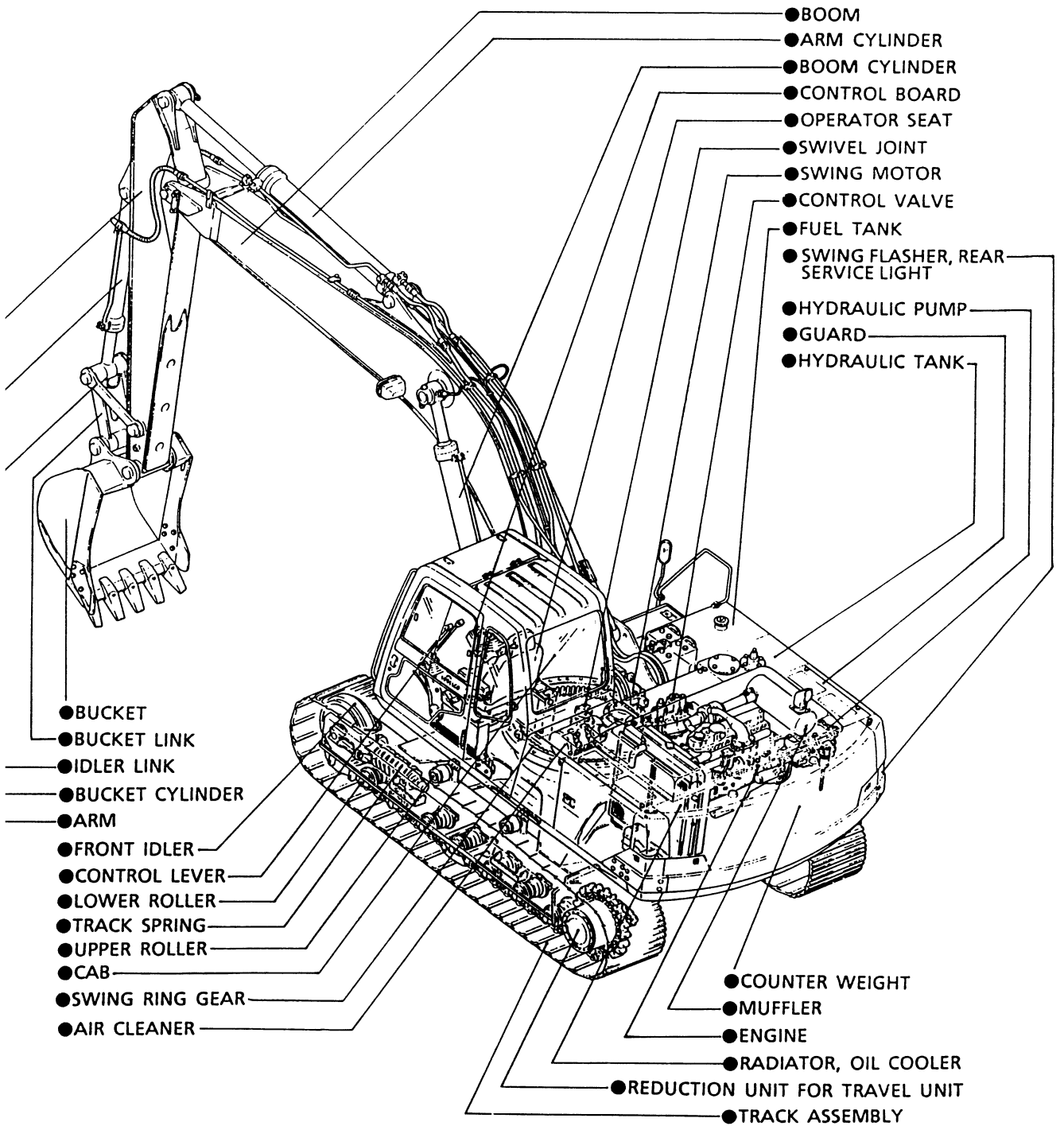

2. WEIGHT OF COMPONENTS (DRY WEIGHT)

Unit : kg (lbs)

Item	Model	SK220LC
Complete machine (std Export 800mm (32") shoe)		24,400(53,800)
1. Upper frame assy (incl. 1.1~1.9)		9,980(22,000)
1.1 · Counter-weight		4,460(9,800)
1.2 · Cab		260(570)
1.3 · Boom cylinder	※	220(490) × 2
1.4 · Engine, radiator	※	660(1,460)
1.5 · Pump assy		260(570)
1.6 · Control valve		130(290)
1.7 · Fuel tank	※	84(190)
1.8 · Hydraulic tank	※	190(420)
1.9 · Swing motor & reduction unit		340(750)
2. Lower frame assy (incl. 2.1~2.9)		10,350(22,800)
2.1 · Slwing ring		355(780)
2.2 · Travel motor & reduction unit		810(1,790)
2.3 · Idler assy		130(280) × 2
2.4 · Lower roller assy		44(97) × 18
2.5 · Upper roller assy		19(42) × 4
2.6 · Track tension assy		155(340) × 2
2.7 · Sprocket		66(150) × 2
2.8 · Swivel joint		30(66)
2.9 · Track link with 600mm (24") shoe assy (O.P.T)		3,410(7,520)
· Track link with 700mm (28") shoe assy (O.P.T)		3,820(8,400)
· Track link with 800mm (32") shoe assy		4,310(9,500)
2.9.1 · Track link		710(1,560) × 2
3. Attachment (incl. 3.1~3.3)		4,070(9,000)
3.1 · Bucket assy (0.9 m ³ (1.18cuyd) STD)		825(1,820)
3.2 · Arm assy (2.98m (9ft-9in) STD.) (incl. following)		1,150(2,500)
3.2.1 · · Arm		750(1,600)
3.2.2 · · Bucket cylinder	※	180(400)
3.2.3 · · Idler link		57(130)
3.2.4 · · Bucket link		107(236)
3.2.5 · · Pin (2 pcs for mounting the arm cylinder and the bucket)		41(90)
3.3 · Boom assy (includes the following :)		2,090(4,608)
3.3.1 · · Boom		1,720(3792)
3.3.2 · · Arm cylinder	※	320(700)
3.3.3 · · Pin (mounting the arm)		29(64)
4. Oil, grease, water, etc. (incl. 4.1~4.3)		580(1,276)
4.1 · · Hydraulic oil, engine oil		290(639)
4.2 · · Fuel		260(567)
4.3 · · Water		32(71)

※ mark dry weight.

3. TRANSPORTATION WEIGHT

3.1 PRINCIPAL PARTICULARS OF A FULLY-EQUIPPED MACHINE ON A TRAILER

	Width of shoe 600mm (24")	Width of shoe 800mm (32")
Total width	3,190mm [10 ft-6 in]	3,390mm [11 ft-1in]
Weight	23.5ton[51,800 lbs]	24.4ton[53,800 lbs]

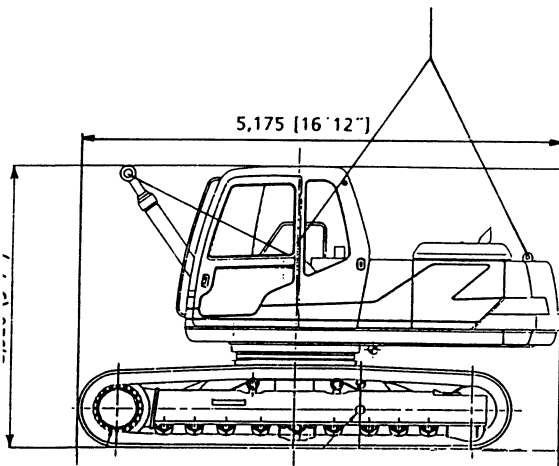
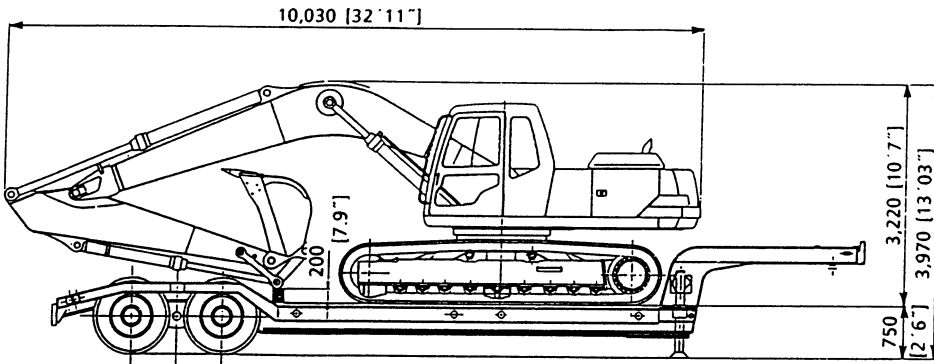

3.2 BASIC MACHINE LIFTING

	Width of shoe 600mm (24")	Width of shoe 800mm (32")
Width	3,190mm (10ft-6in)	3,390mm [11 ft-1in]
Weight	19.7ton (43,400 lbs)	20.6ton[45,400 lbs]

3 PRINCIPAL PARTICULARS OF BOOM

	6.02m [19ft-9 in] boom
total length x total height x total width LxHxW m [ft-in]	6.24 x 1.65 x 0.75 [20'7" x 5'5" x 2'6"]
Weight kg [lbs]	1,990 [4,390]

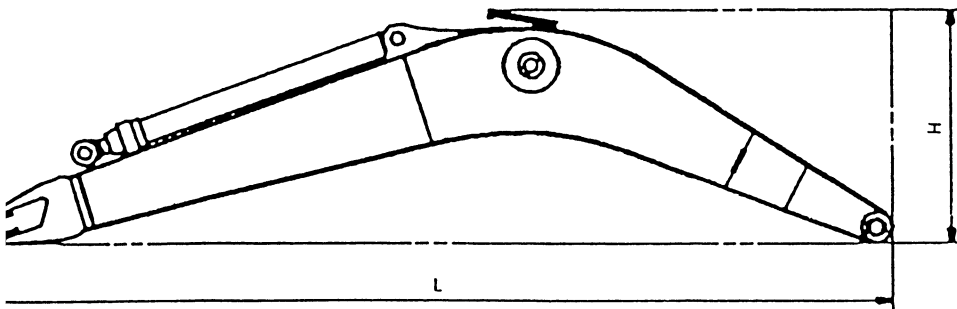

3.4 PRINCIPAL PARTICULARS OF ARM + BUCKET

Combination	2.5m[8ft-2 in] arm + 1.0m ³ [1.31cuyd] bucket	2.98m[9ft-9 in] arm + 0.9m ³ [1.18cuyd] bucket	3.66m[12ft] arm + 0.7m ³ [0.92cuyd] bucket
Total length x total height x total width L x H x W m [ft-in]	5.02 x 0.98 x 1.38 [16'6" x 3'3" x 4'6"]	5.46 x 0.98 x 1.27 [17'11" x 3'3" x 4'2"]	6.15 x 0.98 x 1.05 [20'2" x 3'3" x 3'5"]
Weight kg [lbs]	1,940 [4,280]	1,940 [4,280]	2,010 [4,400]

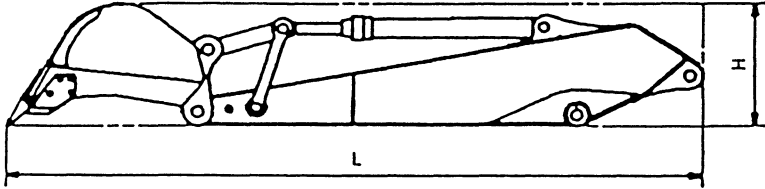

3.5 PRINCIPAL PARTICULARS OF ARM

Length of arm	2.5m[8ft-2 in] arm	2.98m[9ft-9 in] arm	3.66m[12ft] arm
Total length x total height x total width L x H x W m [ft-in]	3.59 x 0.94 x 0.43 [11'9" x 3'1" x 1'5"]	4.04 x 0.89 x 0.43 [13'3" x 2'11" x 1'5"]	4.73 x 0.92 x 0.43 [15'6" x 3'0" x 1'5"]
Weight kg [lbs]	1,060 [2,340]	1,110 [2,450]	1,270 [2,800]

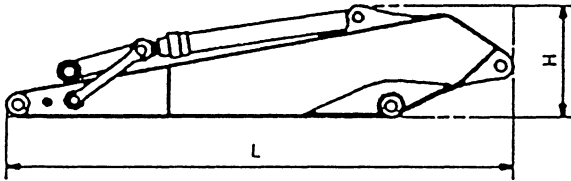

3.6 PRINCIPAL PARTICULARS OF BUCKET

Type	Hoe bucket			
Total length x total height x total width L x H x W m [ft-in]	1.49 x 1.34 x 1.05 [4'11" x 4'5" x 3'5"]	1.49 x 1.34 x 1.27 [4'11" x 4'5" x 4'2"]	1.49 x 1.34 x 1.38 [4'11" x 4'5" x 4'6"]	1.49 x 1.34 x 1.60 [4'11" x 4'5" x 5'3"]
Weight kg [lbs]	690 [1,520]	770 [1,700]	830 [1,830]	900 [1,980]
Bucket capacity m ³ [cuyd]	0.7 [0.92]	0.9 [1.18]	1.0 [1.31]	1.2 [1.57]
Type	Slope facing bucket	Ripper		
Total length x total height x total width L x H x W m [ft-in]	1.39 x 0.96 x 2.20 [4'7" x 3'1" x 7'3"]	1.57 x 0.89 x 0.48 [5'2" x 2'11" x 1'7"]		
Weight kg [lbs]	1,050 [2,320]	620 [1,370]		
Bucket capacity m ³ [cuyd]	—	—		

● Hoe bucket

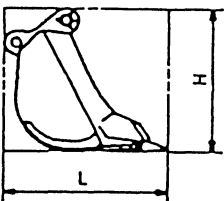

● Slope facing bucket

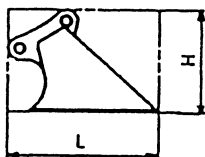

● Ripper

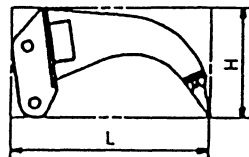

KOBELCO

Book code No. ^{5/94} S5LLU0403E①

SHOP MANUAL

SK 220LC

MAINTENANCE STANDARDS AND TEST PROCEDURES

TABLE OF CONTENTS

LLU04

1. GENERAL	1
2. MEASUREMENT AND ADJUSTMENT	
2.1 Equipment to be Prepared	2
2.2 Standard Measuring Condition	2
2.3 Reading the Engine Revolution	2
2.4 Mechatronic Adjustment	3
2.5 Measuring the Pilot Circuit Pressure	7
2.6 Measuring and Adjusting the Circuit Pressures	7
2.7 Performance Inspection Standard	10
2.8 Procedure for Adjusting the Pressure of Independent Relief Valves	11
2.9 Measuring the Loading Mode Pressure (OPT.)	12
2.10 Measuring the Pressure of Pump (P2) in Loading Mode	12
2.11 Measuring the Secondary Pressure of KPSS Solenoid Proportionate Valve ..	13
2.12 Procedure for Measurement and Adjustment of Negative Control Relief Pressure ...	13
3. CYLINDER SPEED	14
4. CYLINDER OIL TIGHTNESS	15
5. SWING PERFORMANCE	16
6. TRAVEL PERFORMANCE	17
7. OIL DRAIN FROM MOTORS	18
8. PLAY OF SWING BEARING	19

KOBELCO CONSTRUCTION MACHINERY(U.S.A.) INC.

Applicable Machines
LLU-00301~

Recd 5/94

Revision	Date of Issue	Remarks
First edition	October, 1990	S5LLU0403E K
First revision	December, 1993	S5LLU0403E① K

1. GENERAL

- 1) The terms used in this Maintenance Standards shall have definitions as follows:

Standard value :

Standard values for adjustment or assembly of a new machine, provided the values are for standard specifications (machine with standard attachments and shoes) unless otherwise specified.

Allowable value :

A limit value that shall not be exceeded. If it is exceeded, remedy or replacement is required. Avoid using a machine, exceeding this value to maintain the performance or safety of the machine.

Limit value of use :

A value at which machine adjustment or parts replacement becomes unnecessary if it is exceeded. If the machine is still used beyond the limit value, the machine will be faced with failures leading to the out-of operation and will develop safety problems.

Oil temperature :

Temperature to be applied. The temperature of hydraulic oil refers to that in the hydraulic oil tank. Hydraulic oil must be circulated continuously so that the oil temperature in the circuits may be leveled off with that of the tank.

- 2) For items without allowable values, adjust and repair or replace them with reference to the standard values.
- 3) Rubber products such as hydraulic hoses, O rings and oil seals deteriorate with time. Replace them regularly or at overhaul.
- 4) It is advisable that important hoses for safety purpose be designated as very important parts (V.I.P.) and be replaced regularly.
- 5) In proceeding to maintenance, it is essential to get familiar with machine operating procedures, precautions to be observed and inspection / lubrication procedures. Read through the Operators Manual as well.

2. MEASUREMENT AND ADJUSTMENT

2.1 EQUIPMENT TO BE PREPARED

Pressure gauge	70kgf/cm ² (1000 psi)	3 pcs
	500kgf/cm ² (7000 psi)	2 pcs
Pressure measuring set		1 set
Surface thermometer (with magnet)		1 pcs
Hydraulic oil analyzing apparatus		1 set

2.2 STANDARD MEASURING CONDITION

Within standard measuring condition in Performance Inspection Standard Table (Table 1)

(1) Measuring Procedure and Method

- 1) Measuring the cleanliness of operating oil
Measure cleanliness with an analysis apparatus after taking sample oil from the operating oil
If the oil shows a cleanliness exceeding an allowable value, flush the oil or replace the filter.
- 2) Raising the temperature of the operating oil
Attach a thermometer in the surface of the operating oil tank and measure temperature. Wait till the temperature rises by raising the boom or by relieving the bucket relief valve.
- 3) Raising the water temperature
Attach a thermometer in the surface of the radiator and measure the temperature. Run the engine and wait till temperature rises.

2.3 READING THE ENGINE REVOLUTION

Following is a procedure whereby the engine revolution is read on the multi-display:

- 1) With the buzzer stop switch turned to "ON", turn the starter key switch to "ON". However, keep the engine stopped. (See Fig. 2.)
- 2) Depress the buzzer stop switch five times and get an engine rotation mark and a controller part number.
- 3) Depress the buzzer stop switch by turns. An engine revolution will be indicated at the 23rd out of 24 pressings. (Fig. 3.)
- 4) If the engine is started here, the display will be as shown on the right, for instance. (Fig. 4.)
- 5) Set the throttle lever to the maximum revolution "HI".
- 6) Change over the operation mode (KPSS) switch to H,S,FC,D by turns and compare the revolution at no load with an present revolution.
- 7) If the revolution falls within a tolerance, determine that the engine and the controller are normal, and measure and adjust the pressure of the hydraulic circuit.

Revolution at no load = present revolution

- 8) If the revolution runs out of a tolerance, adjust the revolution according to the procedure for the adjustment of the following mechatro controller.

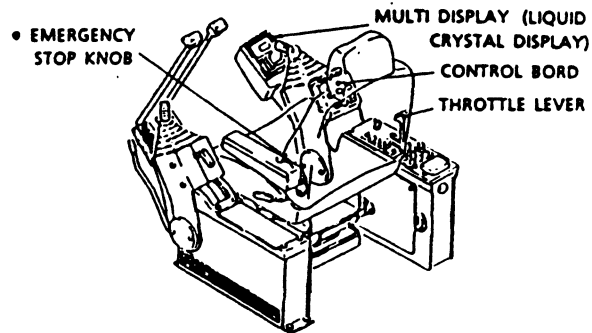

Fig. 1 Operating controls

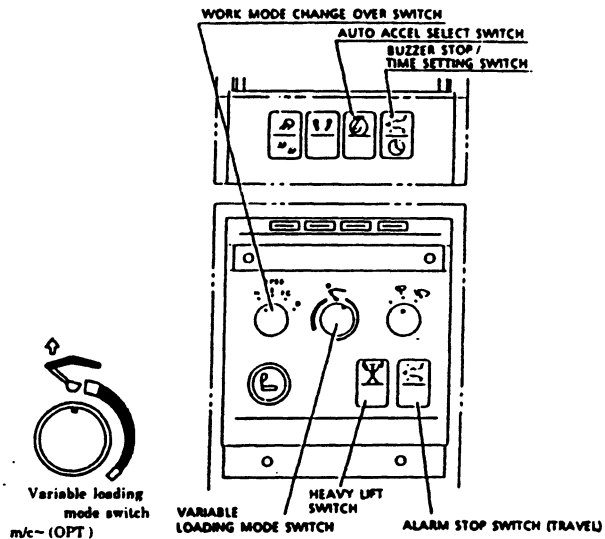

Fig. 2 Control board

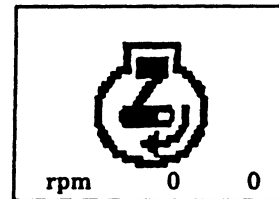

Fig. 3 Displaying the engine revolution when the engine is at rest

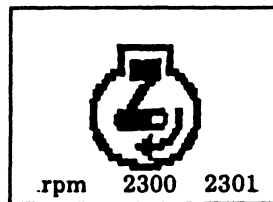

Fig. 4 An example of engine revolution display when running

- 2301 ...Present revolution
- 2300 ...No-load revolution at mechatro adjustment (Hereinafter called no-load revolution)
- rpmRevolution



Suggest:

For more complete manuals. Please go to the home page.

<https://www.ebooklibonline.com>

If the above button click is invalid. Please download this document first, and then click the above link to download the complete manual.

Thank you so much for reading

2.4 MECHATRONIC ADJUSTMENT

If part is to be replaced	Perform	
	Adjust A	Adjust B
Mechatronic controller (KPSS)	○	○
Stepping motor	○	—
Electromagnetic proportionate reducing valve for loading mode	—	OPT.○

When the above-mentioned parts have been replaced, do not fail to perform mechatronic adjustment. That is to say, adjustment A refers to the adjustment of engine revolution, while adjustment B represents the adjustment of the loading mode. These adjustments consist of adjustment procedure, adjustment timing, etc. Always observe the following procedures for adjustment.

2.4.1 PROCEDURE OF ADJUSTING ENGINE (RPM) REVOLUTIONS—PERFORM ADJ. A.

- (1) Procedure for setting the engine stop position
 1) Turn the engine key to "OFF".

- ⚠** The power supply turns off four seconds after the engine key is turned to "OFF". If the internal adjusting switch (3 of Fig 7) is moved over when the power is on, adjustment data may be lost. Be careful if the engine key is set to "OFF" while performing mechatronic adjustment.
- 2) Remove the operator seat and controller cover fixed to the seat stand. (Fig. 5.)
 3) Pull out the 1P coupler from the mechatronic controller (KPSS) and connect the 1P coupler of the adjustment harness as in the figure on the right.
 4) Remove cap (2) of the controller. After confirming that the engine key is "OFF", put your finger into the hole in the rubber cap, push the adjust switch (3) in the controller toward test.
 5) Set the adjustment start condition (1).
 6) Press the adjustment harness pushbutton and release it after 3 to 5 seconds as soon as CPU is displayed on gauge cluster display.

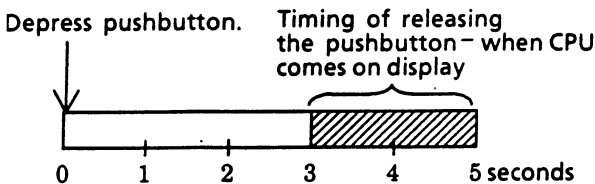

🔍 If [CPU] is indicated on the multi display, it means that the ADJ. mode has been entered. If [TIME] or [MARK III] is indicated instead of [CPU], adjustment conditions are wrong or the pushbutton adjustment timing is incorrect. Reconfirm adjustment conditions and push adjustment harness switch 3~5 seconds again until CPU is displayed.

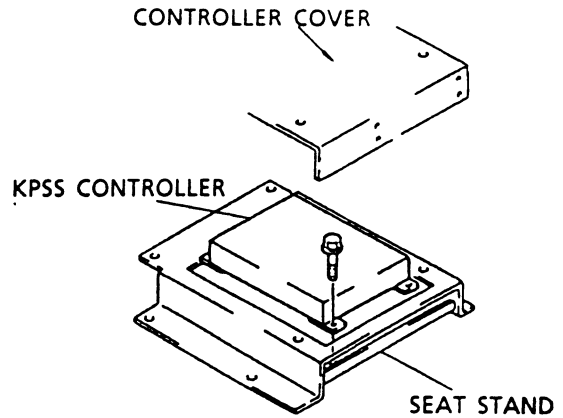

Fig. 5 KPSS controller and seat stand

A. ADJUSTMENT START CONDITIONS (1)

① Internal adjustment switch	Test
② Working mode	H mode
③ Auto accel	ON
④ Throttle lever	Low idling
⑤ Engine	Stop (Key ON)

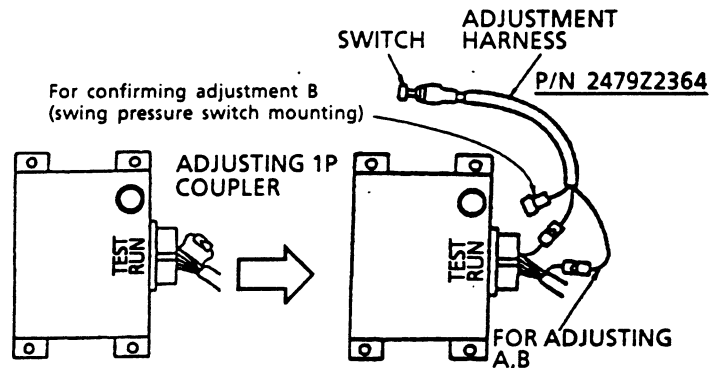

Fig. 6 Adjusting harness

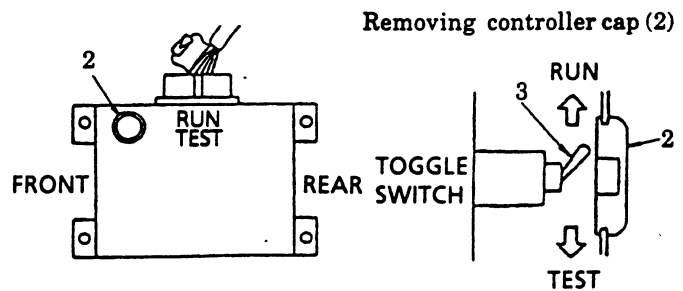

Fig. 7 Direction of pushing the adjust switch in the controller

⚠ Adjustment data may be broken unless the switch (3) is pressed with the engine key in "OFF" position.

- 7) When [CPU] is displayed, the stepping motor is fixed at the engine stop position.
- 8) Adjust dimension what dim. A of the governor rod and install in the engine stop position. Tighten the locknut when the clearance between the governor lever and the engine stop bolt is 0.1mm (0.004in). After tightening the locknut, make sure of the clearance again. In case the clearance is not 0.1mm (0.004in), loosen and adjust the locknut once again.

- 7 Governor
- 8 Stepping motor lever
- 9 Adjusting rod
- 10 Stepping motor
- 11 Emergency stop cable
- 12 High idle set screw
- 13 Engine stop setscrew

(2) Procedure of setting the engine high idle position

- 1) Push the adjusting harness pushbutton and, power to the stepping motor is cut off, making the stepping motor free.
- 2) Put a 0.2mm (0.008in) feeler gauge between the high idle setscrew. Move the now freed governor lever and press it hard against the feeler gauge so the lever contacts the setscrew.
- 3) With the governor lever pressed, push the adjusting harness pushbutton. Power is now supplied to the stepping motor whereby it is fixed in the high idle position.
- 4) After the lever is fixed in the high idle position, make sure of the clearance of 0.2mm (0.008in).
- 5) If the clearance is out of the clearance standard, clearance adjustment may be carried out, as follows :

When the clearance is large ;

If the auto accel switch is turned on and the buzzer stop switch is pressed one time, the clearance decreases by about 0.04mm (0.002in).

When the clearance is small ;

If the auto accel switch is turned off and the buzzer switch is pressed once, the clearance increases by about 0.04mm (0.002in).

- 6) If the adjusting harness pushbutton is pushed after the clearance adjustment, the stepping motor memorizes the high idle position and returns to the start position.
- 7) Memorization is complete when the indication on the multi display has changed from [CPU] to [TIME] or [MARKIII]. (m/c~)

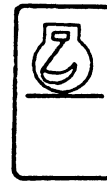

Fig. 8 Auto accel select switch
ADJUSTING 1P COUPLER (4)

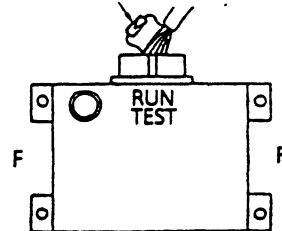

Fig. 9 Position of the adjusting 1P coupler of the controller

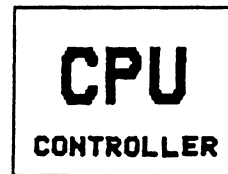

Fig. 10 CPU indication on multi display

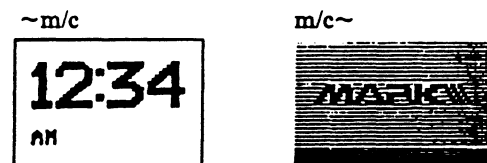
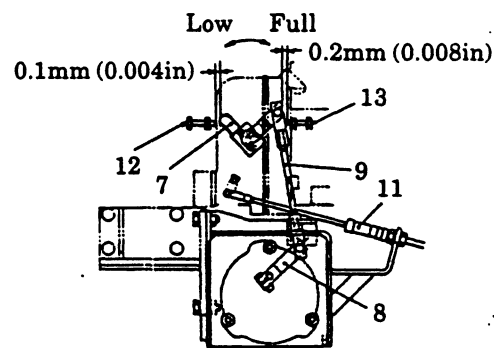

Fig. 11 An example of time display on the multi display



- 7 Governor lever
- 8 Stepping motor lever
- 9 Adjust rod
- 11 Emergency stop cable
- 12 High idle set screw
- 13 Engine stop set screw

Fig. 12 Governor lever adjusting clearance

<https://www.ebooklibonline.com>

Hello dear friend!

Thank you very much for reading.

Enter the link into your browser.

The full manual is available for immediate download.

<https://www.ebooklibonline.com>