

KOBELCO

SHOP MANUAL

HYDRAULIC EXCAVATOR

SK150(LC)IV

ED180(LC)

Applicable: SK150(LC)IV YMU1001~

Applicable: ED180(LC) YLU001~

S5YMU/YL01E-01

04/02

HYDRAULIC EXCAVATOR SK150(LC)IV

model ED180(LC)

SHOP MANUAL INDEX

- 1 SPECIFICATION SECTION
- 2 MAINTANCE SECTION
- 3 SYSTEM SECTION
- 4 DISASSEMBLY SECTION
- 5 TROUBLESHOOTING
- 6 COMPONENTS SECTION
- 7 MISCELLANEOUS

Specifications

Maintenance

System

Disassembling

Troubleshooting

Comp.

Misc.

KOBELCO

Book Code No. S5YMU/YL01E

KOBELCO

SHOP MANUAL *SK150 LC-IV* *ED180*

----- TABLE OF CONTENTS -----

Specifications

Safety
Transportation
Specifications
Attachment Dimensions
Tools
Standard Maintenance Time Table

Maintenance

Measuring and Adjusting Pressures
Cylinder and Motor Cycle Times
Mechatronics

System

Travel System – 150
Travel System – 180
Attachment Disassembly
Mechatronics Control System
Electric System – 150
Electric System – 180

Components

- Hydraulic Pump
Hydraulic Pump
Regulator (KR36-9C)
Hydraulic Gear Pump
- Control Valve
Swing Control Valve
Pilot Valve (TH40K)
Control Valve
Pilot Valve (Travel)
- Other Valves
Holding Valve – Boom Safety
Holding Valve – Boom Lock
Manifold Block
- Hydraulic Motor
Hydraulic Swing Motor
Hydraulic Travel Motor
- Swivel Joint
- Hydraulic Cylinder
- Reduction Unit (Swing)

Troubleshooting

Components (180 Specific)

<https://www.ebooklibonline.com>

Hello dear friend!

Thank you very much for reading.

Enter the link into your browser.

The full manual is available for immediate download.

<https://www.ebooklibonline.com>

GENERAL INFORMATION

4.1 GENERAL INFORMATION

WARNING

READ, UNDERSTAND AND FOLLOW ALL SAFETY PRECAUTIONS CONTAINED IN THIS MANUAL BEFORE PERFORMING ANY INSPECTION OR MAINTENANCE PROCEDURES ON THIS MACHINE, ITS SYSTEMS OR COMPONENTS.

- A. It is recommended by KOBELCO AMERICA INC., that an inspection and maintenance schedule be developed and maintained on a regular basis for this machine. Developing and maintaining such a schedule, helps to keep the machine in optimum operating condition. See Figure 4.3A.
- B. The information contained in this section gives the proper procedures for performing inspection and maintenance functions for this machine. Use these procedures when performing inspection and maintenance as they will guide the technician step by step for each procedure. Also, refer to the Inspection and maintenance charts for general service interval recommendations.

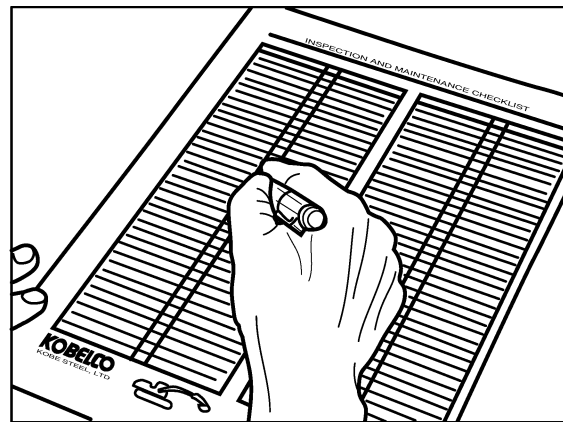

FIGURE 4.3A



SK32004002

FIGURE 4.3B

NOTE

The inspection and maintenance charts provided in this section give only general time intervals. It may be necessary to develop a custom schedule to perform machine maintenance at more frequent intervals based on the work conditions.

- C. Use only KOBELCO oils, fluids, lubricants, filters and replacement parts to keep machine in optimum operating condition. See Figure 4.3B.

4.2 GENERAL SAFETY

- A. **Disposal of Hazardous Waste— FIGURE 4.3C**
Dispose of waste oils, fluids, lubricants, filters and other hazardous waste properly.

Dispose of Waste Properly

SK32004003

FIGURE 4.3C

CAUTION

Dispose of all hazardous waste in accordance with government environmental regulations, laws and codes.

- B. **Keep Machine Clean— FIGURE 4.3D**
Thoroughly clean machine before performing inspection and maintenance procedures. It is easier and safer to locate problems, perform maintenance and also reduce the risk of hydraulic system contamination when machine is clean.

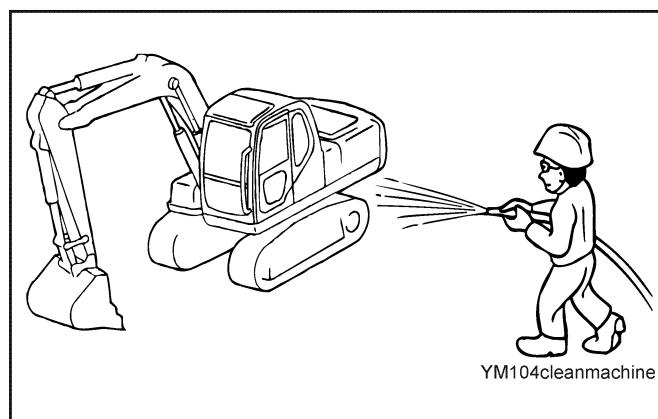

YM104cleanmachine

FIGURE 4.3D

GENERAL INFORMATION

C. Hot Surfaces & Fluids– FIGURE 4.4A

Use caution and wear the proper safety equipment when working around hot areas. Never change oils, engine coolant or filters immediately after a machine has been stopped. Allow machine to cool down before performing maintenance procedures.

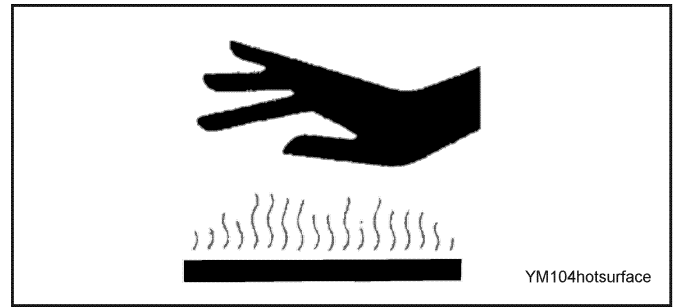

FIGURE 4.4A

D. Warm Engine Oil

Engine oil should have a temperature should be between 20°C ~ 40°C (68°F ~ 104°F) before the oil is changed. If necessary run engine until the oil is warm within the recommended oil change temperature.

E. “Tag-Out” Machine– FIGURE 4.4B

Before beginning any inspection or maintenance procedures, secure a iDO NOT OPERATEi tag to the operators console to inform the operator that the machine will be inoperable for inspection and maintenance. This tag will help prevent accidental starting of the machine. Order tag P/N: YN20T01320P1



FIGURE 4.4B

F. Inspect Waste Oils and Filters– FIGURE 4.4C

Before disposal, inspect all waste oils, fluids and filters for debris and foreign material. It is recommended to cut open the oil filters to determine any abnormal wear.

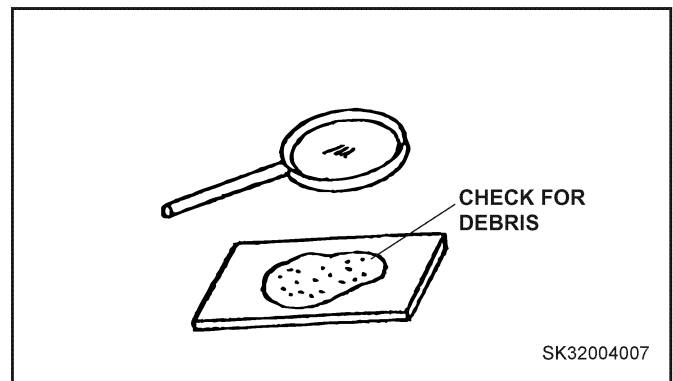

FIGURE 4.4C

G. Prevent Contamination– FIGURE 4.4D

Always cap or plug lines when hydraulic components are removed to help prevent hydraulic system contamination that can be caused by dirt, dust and debris entering a line or port.

CAUTION
Never allow a hydraulic line or component to become contaminated. This could cause severe system damage. Contact an authorized KOBELCO dealer to obtain the proper caps and plugs to be used on this machine. Refer to Specificationis Section, page 6-41, for proper part numbers.

H. Seals & “O”-Rings

Always replace seals and iOi-Rings with new parts. Never reuse a seal or iOi-Ring during reassembly of components. Make sure to lubricate all new seals with the appropriate oil before installation.

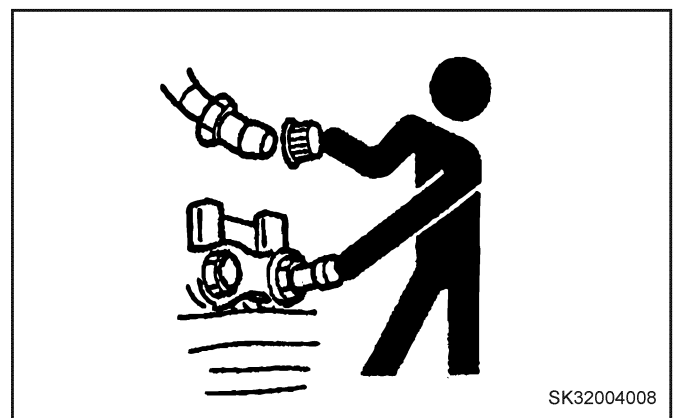

FIGURE 4.4D

GENERAL INFORMATION

I. Stop Engine

Never attempt any MAINTENANCE with engine running. Always stop the engine and allow machine to cool .

J. Wear Safety Equipment– FIGURE 4.5A

Wear hard hat, safety goggles or face shield, work gloves, safety shoes and well fitting work clothes when performing inspection and maintenance procedures on this machine.

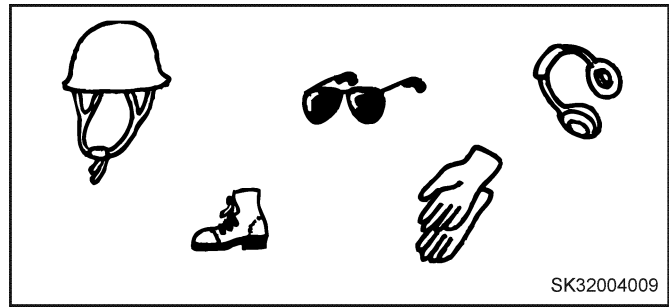

FIGURE 4.5A

K. Cleaning Parts

Use only approved cleaning solvents and proper equipment to clean parts.

WARNING

NEVER USE GASOLINE, DIESEL FUEL OR OTHER FLAMMABLE SOLVENTS TO CLEAN PARTS. ALWAYS CLEAN PARTS IN A WELL VENTILATED AREA.

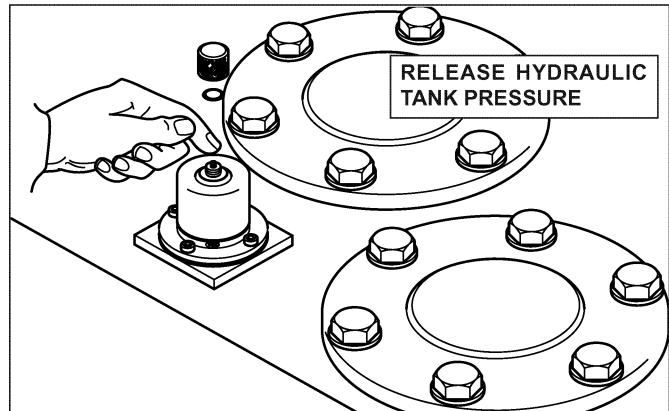

FIGURE 4.5B

L. Hydraulic Tank Pressure

Always release the internal pressure of the hydraulic tank before performing inspection or maintenance procedures.

1. Remove cap and depress valve to release air pressure from the reservoir. See Figure 4.5B.

CAUTION

Gasses from hydraulic tank may be hot. Wear safety equipment.

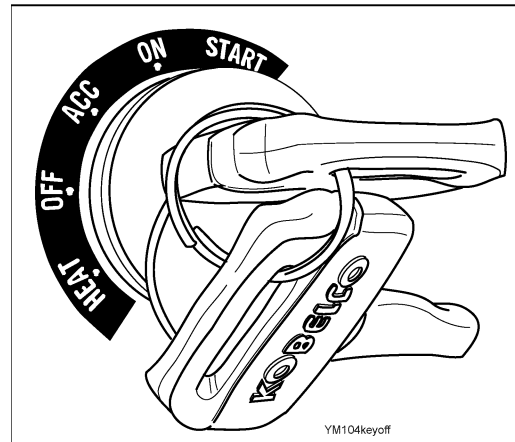

FIGURE 4.5C

M. Welding Safety

1. Turn key switch to iOFFi position. Wait 4 seconds for electrical power to disconnect. See Figure 4.5C.
2. Remove negative (-) cable from battery terminal. See Figure 4.5D.
3. Attach the welder ground cable within 1 M (3i-3i) away from component being welded.
4. Make certain that the welder ground is not located at a seal or bearing.
5. Make certain that no bearings nor seals separates the welder ground and the weld area.

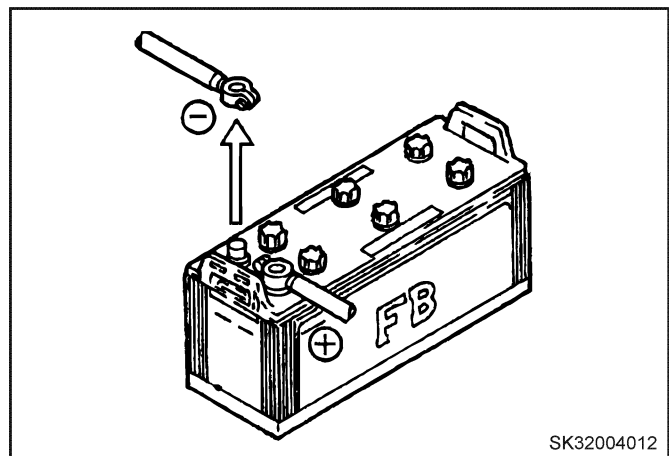

FIGURE 4.5D



Suggest:

For more complete manuals. Please go to the home page.

<https://www.ebooklibonline.com>

If the above button click is invalid. Please download this document first, and then click the above link to download the complete manual.

Thank you so much for reading

GENERAL INFORMATION

N. Releasing Hydraulic System and Tank Pressure.

WARNING

NEVER CHANGE OILS OR FILTERS ON A MACHINE THAT HAS JUST FINISHED WORKING. ALLOW MACHINE TO COOL FIRST UNTIL OILS AND FLUIDS ARE WARM, NOT HOT. RELEASE HYDRAULIC TANK PRESSURE BEFORE WORKING WITH ANY HYDRAULIC COMPONENT.

1. Move the machine to firm level ground and place the attachments on the ground in the oil check position as shown in Figure 4.6A.
2. Stop the engine. Make sure to place the ignition key in iON position and the safety lever is in the unlocked (down) position, ver Fig. 4.6B.
3. Lower the safety lever to unlock the hydraulic system.
4. Shift the right and left travel control levers forward and backward, also operate the right and left control levers as well as the dozer control to full strokes several times, see Fig. 4.6C.
5. Remove cap and depress hydraulic relief valve located on the upper surface of hydraulic tank to release the pressure in the hydraulic tank. See Figure 4.6B.
6. Carry out the inspection and/or maintenance of hydraulic system.

WARNING

WHEN REPLACING ANY HOSE OR SEALS, MAKE SURE THE ATTACHMENTS ARE WELL SECURED TO AVOID SUDDEN MOVEMENT OF ATTACHMENT. SLOWLY REMOVE BOLTS TO RELEASE ANY HYDRAULIC PRESSURE DURING DISASSEMBLY.

NOTE

THE HYDRAULIC RELIEF VALVE ON SOME OF THE MACHINES DO NOT HAVE A RUBBER CAP; INSTEAD THESE VALVES HAVE A HARD CAP. ON THESE VALVES, REMOVE HARD CAP BEFORE DEPRESSING TO RELEASE HYDRAULIC TANK PRESSURE.

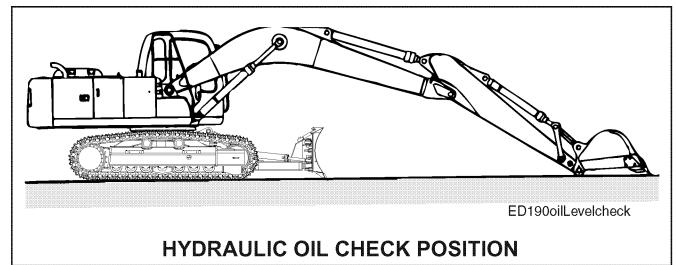

FIGURE 4.6A

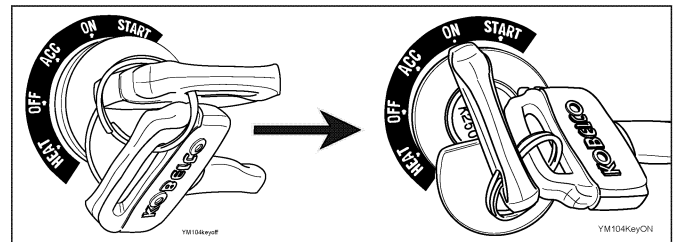

FIGURE 4.6B

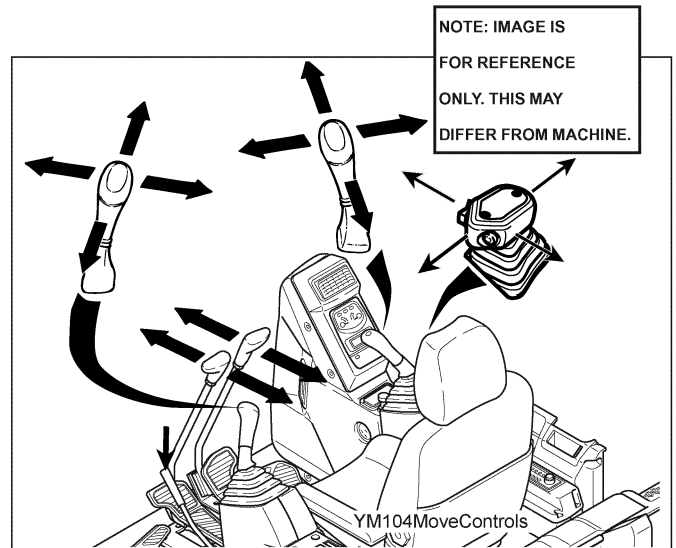

FIGURE 4.6C

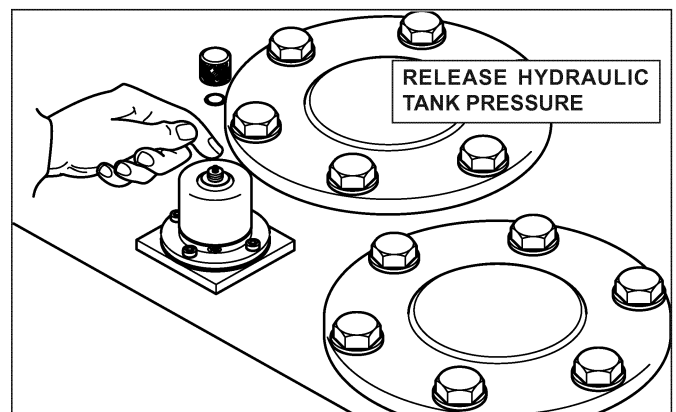

FIGURE 4.6D

GENERAL INFORMATION

O. Guidelines to replace ground tools.

It is very important to keep bucket teeth & side cutters, as well as dozer cutting edges properly tighten. Loose or missing bolts will increase loads and eventually cause tool failure. Furthermore, extended operation with loose hardware can cause the bolts to stretch and wear on the support mounting holes. Also, heating of hardware and support mounting holes will cause the same effect. All these factors will lead to more expensive corrective maintenance. Follow these general guidelines to insure proper tightness of hardware on bucket teeth & side cutters, and dozer cutting edges:

ó When installing new cutting edges, end bits, side cutters and bucket teeth, make sure that all supporting surfaces are free of dirt, paint, debris, rust, scale or weld splatter. All mating surfaces must be clean and flat to insure that maximum clamping force is obtained.

ó Make sure that all bolts and nut threads are clean and dry. **DO NOT APPLY ANY TYPE OF LUBRICANT.**

ó When installing cutting edges bolts, always start at the center and work your way out toward the ends, or begin at one end and work toward the other end. **NEVER WORK FROM BOTH ENDS TOWARD THE CENTER.**

ó When installing end bits, start at the center and work toward the outside edges. Finish installation by torquing from the center toward edges.

ó Always, torque bolts according to specifications.

ó For best results, strike all head bolts with a heavy hammer to seat them properly before final torque.

WARNING

WEAR SAFETY GLASSES WHENEVER STRIKING METAL OBJECTS WITH A HAMMER.

ó When new parts are used, the mating surfaces will seat more uniformly and the bolts torque will be less than the standard value, after a short period of operation. Make sure to check all bolts for proper tightness on new parts after eight (8) hours of operation.

ó Avoid excessive speeds during dozing operations.
ó Lower maintenance costs by replacing, turning, or rotating cutting edges before they reach their wear limits.

ó When finding loose bolts, check bolts for elongation and support mount holes for wear. Replace bolts and repair any wear on support mount hole if needed. Torque bolts according to specs.

P. Guidelines for Attachment Lubrication

Lubricate attachment pins according to the intervals indicated in page 4-10. Use extreme pressure multipurpose grease No 2 EP Type. Lubricate all points until grease purges. The lubrication intervals are based on a standard excavator, see Section 6 of this manual for Kobelco definition of a standard ex-

cavator, working in an **average duty cycle**.

Average duty cycle is defined as (Most typical digging application, road construction in natural bed clay, digging 50 ~ 60 % of the daily work schedule). New pins and bushings, including new machines and repairs require special break-in procedures. While both pin and bushing have a special ground finish, they still have to be mated to each other to eliminate the machining high points, see Fig. 4.7A. Be-

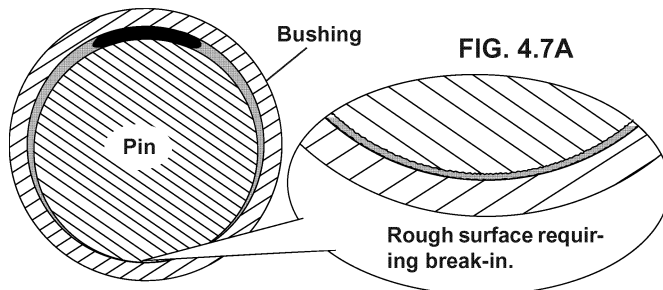

cause of these high spots, it is recommended that the front attachment or the repaired area be lubricated a minimum of once every eight (8) hours for the first one hundred (100) hours for a standard machine working in an average duty cycle. All other machines should be lubricated every 4 hours for the first twenty (20) hours and every eight (8) hours for the next eighty (80) hours of operation. This lubrication procedure will reduce the possibility of a premature pin or bushing failure during the break-in process.

SPECIAL CONSIDERATIONS FOR HAND LUBRICATION:

While grease grooves in the bushings allow grease to move around the bushing, it does not insure that grease gets on all of the bushing surfaces. Any load on the joint will prevent the grease from getting to the wear surface in the loaded area. Due to the fact that a hand greaser does not provide the volume of grease that a power system does, there is a greater possibility of bushing galling, un-

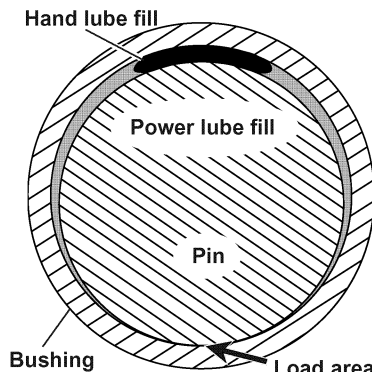

less the standard lubrication procedure is modified. Fig. 4.7B illustrates the pin load and grease cavity discussed above. No matter how much grease is pumped into the pin bushing cavity with a hand grease gun, the grease will tend to escape to the outside before filling the grease cavity. Therefore, to

avoid this situation, the front attachment has to be repositioned during the lubrication process, to move the load area and allow the grease to cover the entire grease cavity between the pin and bushing.

<https://www.ebooklibonline.com>

Hello dear friend!

Thank you very much for reading.

Enter the link into your browser.

The full manual is available for immediate download.

<https://www.ebooklibonline.com>