

KOBELCO

SERVICE MANUAL

HYDRAULIC EXCAVATOR

SK115DZLC IV

SK120LC IV

Revision Date: 01/1995

Applicable: SK115DZLC IV YWU1001~
SK120LC IV LPU1001~, YPU1001~
S5LPU0005E(PLM)

HYDRAULIC EXCAVATOR

SK115DZ LC IV

SK120LCIV

MODEL

YWU

LPU • YPU

BOOK CODE NO. S5LPU0005E(PLM)



WARNING



KOBELCO cannot anticipate every possible circumstance that might involve a potential hazard. The warnings in this publication and on the product are therefore not all inclusive. If a tool, procedure, work method or operating technique not specifically recommended by KOBELCO is used, you must satisfy yourself that it is safe for you and others. You should also ensure that the product will not be damaged or made unsafe by the operation, lubrication, maintenance or repair procedures you choose.

SAFETY



WARNING



The proper and safe lubrication and maintenance for this machine, recommended by KOBELCO are outlined in the OPERATION & MAINTENANCE GUIDE for this machine.

Improper performance of lubrication or maintenance procedures is dangerous and could result in injury or death. Read and understand the OPERATION & MAINTENANCE GUIDE before performing any lubrication or maintenance.

The serviceman or mechanic may be unfamiliar with many of the systems on this machine. This makes it important to use caution when performing service work. A knowledge of the system and or components is important before the removal or disassembly of any component.

Because of the size of some of the machine components, the serviceman or mechanic should check the weights noted in this Manual. Use proper lifting procedures when removing any components.

Following is a list of basic precautions that should always be observed:

1. Read and understand all Warning plates and decals on the machine before operating, lubrication or repairing this product.
2. Always wear protective glasses and protective shoes when working around machines. In particular, wear protective glasses when pounding on any part of the machine or its attachments with a hammer or sledge. Use welders gloves, hood/goggles, apron and other protective clothing appropriate to the welding job being performed. Do not wear loose-fitting or torn clothing. Remove all rings from fingers when working on machinery.
3. Disconnect battery and discharge any capacitors before starting to work on machine. Hang "Do Not Operate" tag in the Operator's compartment.



WARNING



Do not operate this machine unless you have read and understand the instructions in the OPERATOR'S MANUAL. Improper machine operation is dangerous and could result in injury or death.

4. If possible, make all repairs with the machine parked on a level, hard surface. Block machine so it does not roll while working on or under machine.
5. Do not work on any machine that is supported only by lift jacks or a hoist. Always use blocks or jack stands to support the machine before performing any disassembly.
6. Relieve all pressure in air, oil or water systems before any lines, fittings or related items are disconnected or removed. Always make sure all raised components are blocked correctly and be alert for possible pressure when disconnecting any device form a system that utilizes pressure.
7. Lower the bucket, blade, ripper or other implements to the ground before performing any work on the machine. If this cannot be done, make sure the bucket, blade, ripper or other implement is blocked correctly to prevent it from dropping unexpectedly.
8. Use steps and grab handles when mounting or dismounting a machine. Clean any mud or debris from steps, walkways or work platforms before using. Always face machine when using steps, ladders and walkways. When it is not possible to use the designed access system, provide ladders, scaffolds, or work platforms to perform safe repair operations.
9. To avoid back injury, use a hoist when lifting components which weigh 23 kg (50lbs) or more. Make sure all chins, hooks, slings, etc., are in good condition and are in the correct capacity. Be sure hooks are positioned correctly. Lifting eyes are not to be side loaded during a lifting operation.

<https://www.ebooklibonline.com>

Hello dear friend!

Thank you very much for reading.

Enter the link into your browser.

The full manual is available for immediate download.

<https://www.ebooklibonline.com>

10. To avoid burns, be alert for hot parts on machines which have just been stopped and hot fluids in lines, tubes and compartments.
 11. Be careful when removing cover plates. Gradually back off the last two bolts or nuts located at opposite ends of the cover or device and pry cover loose to relieve any spring or other pressure, before removing the last two bolts or nuts completely.
 12. Be careful when removing filler caps, breathers and plugs on the machine. Hold a rag over the cap or plug to prevent being sprayed or splashed by liquids under pressure. The danger is even greater if the machine has just been stopped because fluids can be hot.
 13. Always use tools that are in good condition and be sure you understand how to use them before performing any service work.
 14. Reinstall all fasteners with same part number. Do not use a lesser quality fastener if replacements are necessary.
 15. Repairs which require welding should be performed only with the benefit of the appropriate reference information and by personnel adequately trained and knowledgeable in welding procedures. Determine type of metal being welded and select correct welding procedure and electrodes, rods or wire to provide a weld metal strength equivalent at least to that of parent metal. Always disconnect battery during welding operations to protect sensitive electric equipment.
 16. Do not damage wiring during removal operations. Reinstall the wiring so it is not damaged nor will it be damaged in operation by contacting sharp corners, or by rubbing against some object or hot surface. Do not connect wiring to a line containing fluid.
 17. Be sure all protective devices including guards and shields are properly installed and functioning correctly before starting a repair. If a guard or shield must be removed to perform the repair work, use extra caution.
 18. Loose or damaged fuel, lubricant and hydraulic lines, tubes and hoses can cause fires. Do not bend or strike high pressure lines or install ones which have been bent or damaged. Inspect lines, tubes and hoses carefully. Do not check for leaks with your hands. Pin hole (very small) leaks can result in a high velocity oil stream that will be invisible close to the hose. This oil can penetrate the skin and cause personal injury. Use cardboard or paper to locate pin hole leaks.
 19. Tighten connections to the correct torque. Make sure that all heat shields, clamps and guards are installed correctly to avoid excessive heat, vibration or rubbing against other parts during operation. Shields that protect against oil spray onto hot exhaust components in event of a line, tube or seal failure must be installed correctly.
 20. Do not operate a machine if any rotating parts is damaged or contacts any other parts during operation. Any high speed rotating component that has been damaged or altered should be checked for balance before reusing.
 21. On track-type machines, be careful when servicing or separating tracks. Chips can fly when removing or installing a track pin. Wear safety glasses and long sleeve shirts. Track can unroll very quickly when separated. Keep away from front and rear of machine. The machine can move unexpectedly when both tracks are disengaged from the sprockets. Block the machine to prevent it from moving.
 22. Caution should be used to avoid breathing dust that may be generated when handling components containing asbestos fibers. If this dust is inhaled, it can be hazardous to your health. Components in KOBELCO products that may contain asbestos fibers are brake pad, brake band and lining assemblies, clutch plates and some gaskets. The asbestos used in these components is usually bound in a resin or sealed in some way. Normal handling is not hazardous as long as airborne dust which contains asbestos is not generated.
- If dust which may contain asbestos is present, there are several common sense guidelines that should be followed:
- a. Never use compressed air for cleaning.
 - b. avoid brushing or grinding of asbestos containing materials.
 - c. for cleanup, use wet methods or a vacuum equipped with a high efficiency particulate air (HEPA) filter.
 - d. Use exhaust ventilation on permanent machining jobs.
 - e. Wear an approved respirator if there is no other way to control the dust.
 - f. Comply with applicable rules and relations for the work place.
 - g. Follow environmental rules and regulations for disposal of asbestos.
 - h. Avoid areas where asbestos particles may be in the air.

SHOP MANUAL

model

YWU LPU · YPU

TABLE OF CONTENTS

1. SPECIFICATION
2. OPERATION AND CONTROLS (Refer to Operators Manual)
3. LOCATION AND WEIGHT OF COMPONENTS
4. MAINTENANCE STANDARDS AND TEST PROCEDURES
5.
6. PREVENTIVE MAINTENANCE (Refer to Operators Manual)
7. WORKING STANDARDS
8. STANDARD MAN-HOUR TABLE

YPU01

YPU03

YPU04

YPU07

YPU08

○How to Index each Shop Manual Section

The GENERAL of this shop manual consists of 8 headings as shown above. Each section can be easily referred to by indexes appended to the margin of the page as indicated on the right. Please use the indexes for speedy reference.

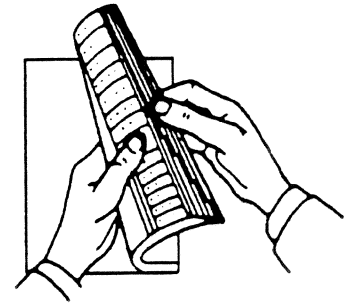

KOBELCO

GENERAL

YWU
LPU
YPU

List of Shop Manual GENERAL Section

Index No.	Title	Book Code No.		
		Distribution Year - Month		
YPU01	SPECIFICATION	S5YPU0105E 1995-01		
—	OPERATION	Refer to Operators Manual		
YPU03	LOCATION AND WEIGHT OF COMPONENTS	S5YPU0305E 1995-01		
YPU04	MAINTENANCE STANDARDS AND TEST PROCEDURES	S5YPU0405E 1995-01		
—	PREVENTIVE MAINTENANCE	Refer to Operators Manual		
YPU07	WORKING STANDARDS	S5YPU0705E 1995-01		
	Applicable Machines	YWU1001~ LPU1001~ YPU1001~		

KOBELCO

SHOP MANUAL

Book code No. S5 YPU01_{05E}

YWU LPU · YPU

YPU01

SPECIFICATION

TABLE OF CONTENTS

1. LOCATION OF COMPONENTS	1
2. GENERAL DIMENSIONS	2
3. SPECIFICATIONS AND PERFORMANCE	4
4. TYPE OF SHOES	5
5. TYPE AND COMBINATION OF ATTACHMENTS ...	6
6. WORKING RANGES OF ATTACHMENTS	8
7. LIFTING-UP ABILITY DIAGRAM	10
8. ENGINE SPECIFICATIONS	17

KOBELCO CONSTRUCTION MACHINERY(U.S.A.) INC.

Applicable Machines

YWU1001~

LPU1001~

YPU1001~

Revision	Date of Issue	Remarks
First edition	January, 1995	S5YPU0105E K

1. LOCATION OF COMPONENTS

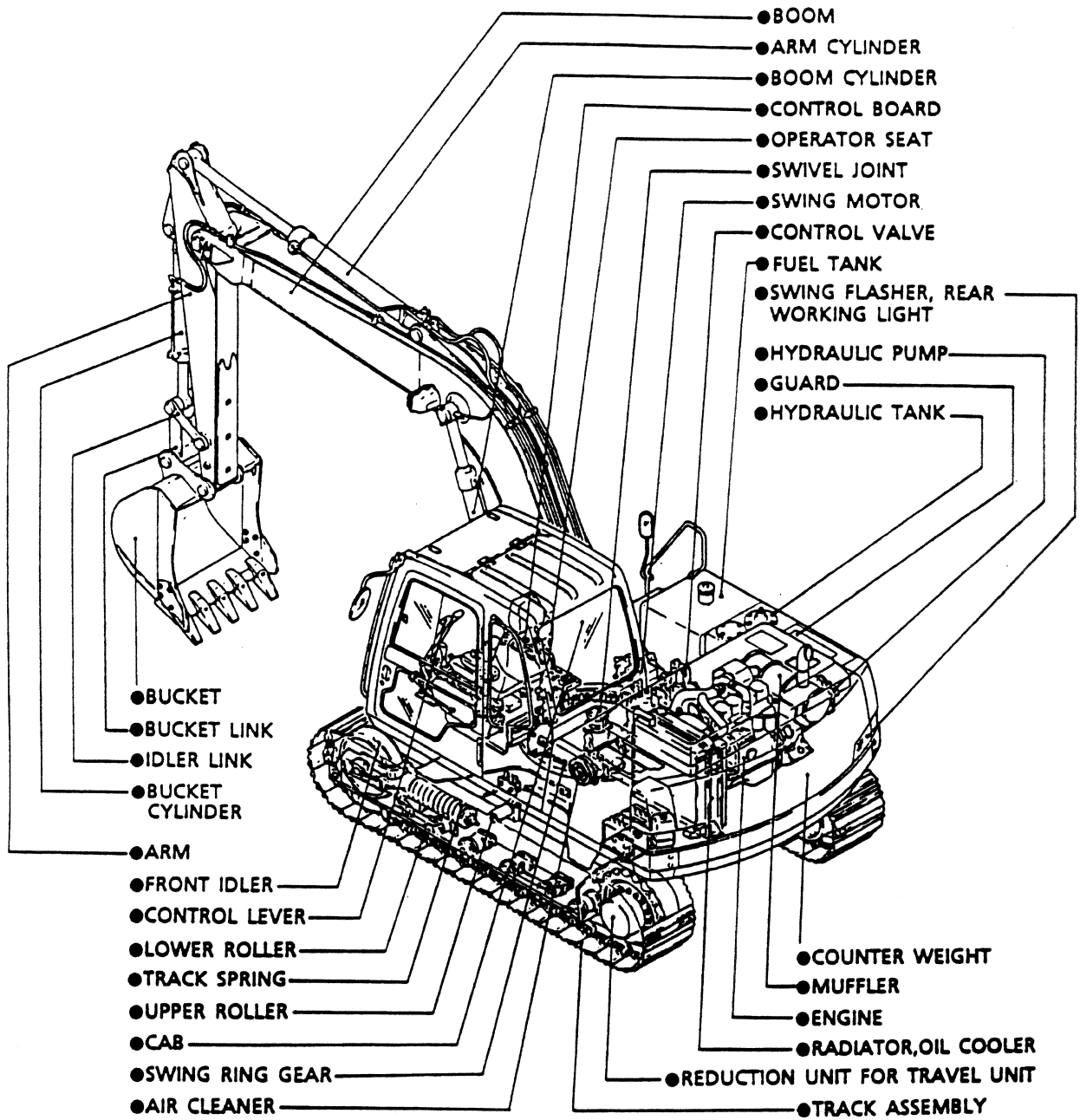

2. GENERAL DIMENSIONS



DIMENSIONS

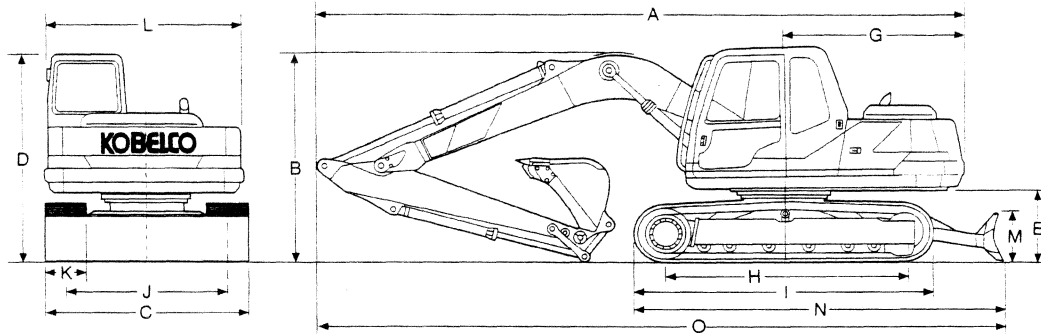

Dimensions

Unit: ft-in (m)

		8 - 2 (2.5m)
Arm length		
A	Overall length	24' 11" (7.6)
B	Overall height (to top of boom)	8 - 8 (2.65)
C	Overall width (blade & track)	8 - 6 (2.59)
D	Overall height (to top of cab)	8 - 11 (2.725)
E	Ground clearance of rear end*	2 - 11 (0.9)
F	Ground clearance*	18" (0.455)
G	Tail swing radius	7 - 1 (2.15)
H	Track on ground	9 - 11 (3.035)
I	Overall length of crawler	11' 6" (3.53)
J	Track gauge	7 - 10 (1.99)
K	Shoe width	23.6" (600mm)
L	Overall width of upper structure	7 - 11 (2.43)
M	Height of blade	2 - 0 (0.61)
N	Length of lower w/blade	14 - 2 (4.28)
O	Transport length	26 - 6 (8.1)

*Does not include height of grouser bar



Suggest:

For more complete manuals. Please go to the home page.

<https://www.ebooklibonline.com>

If the above button click is invalid. Please download this document first, and then click the above link to download the complete manual.

Thank you so much for reading

Technical Data



ENGINE

Model	CUMMINS 4BT3.9, 4-cycle diesel with turbocharger
No. of cylinders	4
Bore and stroke	4.02" (102 mm) x 4.72" (120 mm)
Displacement	239.3 cu in (3,920 cc)
Rated power output	86 HP (63.4 kW) SAE NET at 2,200 rpm (SAE J 1349)
Max. torque	254 lb-ft (344.5 N-m) at 1,500 rpm (SAE J 1349)
Combustion system	Direct injection
Cooling system	Pressurized water circulated by a centrifugal pump
Lubrication system	Pressurized oil fed by a gear pump through full-flow spin-on filters
Starter	Electric, 24 V, 4.0 kW
Alternator	50 AMP
Air cleaner	Dry type with safety element
Batteries	2 x 12 V — (90 AH)
Starting aid	Ether injection system



HYDRAULIC POWER SOURCE

Two variable displacement, axial piston pumps power the boom, arm, bucket, swing and propel circuits. One single section, gear-type pump powers the pilot circuit.

Pump	Two axial-piston, variable displacement pumps and one gear pump
Max. discharge flow	2 x 31 US gal/min (2 x 118 liters/min)
Pilot oil flow	6.2 US gal/min (233 liters/min)
Max. discharge pressure:	
Boom, arm and bucket	4,270 psi (300 kg/cm ²)
Propel circuit	4,980 psi (350 kg/cm ²)
Swing circuit	3,560 psi (250 kg/cm ²)
Control circuit	710 psi (50 kg/cm ²)
Oil filtration	One return filter with replacement element and a suction strainer
Pilot control pump	Gear type
Control valves	5-spool+1-spool
Oil cooler	Finned tube, forced ventilation
Pressure relief valves	Primary and secondary on each circuit



CONTROL AND CAB

The all-weather, die-formed, modular steel cab is mounted on six rubber pads and fitted with a heavy, insulated floor mat. Window area is large, all windows being in tinted, safety glass. The upper front window slides upwards in a single motion for storage under the cab roof and the lower front window is removable. The cloth covered, high-backed seat is adjustable. Travel levers are removable. Toe tabs are installed on propel pedals. Easy-to-read check & safety monitor checks important machine functions and immediately warns the operator of possible machine failures before they develop into serious problems.

Pilot control	Boom, arm, bucket, swing and propel
Engine throttle	Electric, hand lever
Check & Safety Monitor:	
Indicators	Fuel level, water temperature, hour meter, cold oil indicator, low engine oil pressure, high engine temperature
Lamps	Low engine oil pressure, high water temperature, air cleaner restriction, battery charge, low fuel level, starting aid, high speed travel, work lights

Installed as standard equipment is a 24 to 12 volt D.C. power converter for ease of operating customer provided accessories. A convenient 12 volt cigarette lighter type power socket provides the following power source:

Maximum Continuous Output	5 Amps
Maximum Intermittent Output	10 Amps

This same power converter powers the Kobelco optional Delco brand AM/FM Stereo radio sound system.

External lights:

Front	Two lights mounted on the boom, one below the cab, and one under the battery case
Rear	One working light on each side of the counterweight, plus swing flashers



SWING SYSTEM

The hydraulic, gear-driven swing is powered by an axial piston motor that is flange-connected to a planetary reduction unit driving the swing pinion. The single-row ball bearing unit has an integral, internally cut swing gear, and is totally enclosed to prevent the entry of mud and water.

Brake	Hydraulic, locking automatically when the swing control lever is in the neutral position
Parking brake	Hydraulic disc brake
Max. swing speed	12.7 rpm
Tail swing radius	7' 1" (2,150 mm)
Min. front swing radius	8' 4" (2,530 mm)



TRAVEL SYSTEM

The crawler tracks are fitted with interchangeable shoes, and are supported by seven lower rollers, and two upper rollers, with a guardplate on each side. Special track frame design with convenient cleaning holes simplifies mud removal. Spring-loaded track tensioning by the idler wheels protects the drives from shock, and is adjustable by grease cylinders. An all-welded undercarriage frame gives clog-free track clearance, and the drive motors are protected within the shoe width.

Drive motors	Independent, axial-piston, two-step motors for each side, driven through planetary speed reducers
Brakes	Independent, disc parking brakes for each side, applied automatically when the travel levers are in neutral
Track shoes	43 pads each side
Track tensioning	Hydraulic track adjusters and cushion springs
Lubrication	Lubricated rollers and front idlers have floating seals; lubricated and sealed track chains
Max. travel speed:	
High mode	4.3 mph (7.0 km/h)
Low mode	2.5 mph (4.0 km/h)
Drawbar pulling force	24,600 lb (11,160 kg)
Gradeability	70% (35°)
Ground clearance	18" (455 mm)



BOOM, ARM AND BUCKET

The boom and arm feature pressed and welded steel box section. Buckets are fabricated from high tensile strength steel.

Boom cylinders	Two, double-acting 4.1" (105 mm) x 3' 7" (1,097 mm) stroke
Arm cylinder	One, double-acting 4.7" (120 mm) x 3' 10" (1,185 mm) stroke
Bucket cylinder	One, double-acting 3.9" (100 mm) x 3' 0" (915 mm) stroke



REFILLING CAPACITIES AND LUBRICATION

Fuel tank	66 US gal (250 liters)
Cooling system	4.5 US gal (17 liters)
Engine oil	2.9 US gal (11 liters)
Track drives	2 x 0.8 US gal (2 x 3.0 liters)
Swing drive	1.6 US gal (6.2 liters)
Hydraulic oil:	
Tank (oil level)	24 US gal (90 liters)
Hydraulic system	37 US gal (140 liters)
Lubrication:	
Swing system	Grease bath for gear, centralized greasing for bearing
Boom, arm, and attachments	Grease nipples, centralized greasing for remote points

<https://www.ebooklibonline.com>

Hello dear friend!

Thank you very much for reading.

Enter the link into your browser.

The full manual is available for immediate download.

<https://www.ebooklibonline.com>