

HYDRAULIC EXCAVATOR

SHOP
MANUAL model SK30SR-6

INDEX

1	SPECIFICATIONS SECTION
2	MAINTENANCE SECTION
3	SYSTEM SECTION
4	DISASSEMBLY SECTION
5	TROUBLESHOOTING
6	ENGINE SECTION

MAINTENANCE SPECIFICATIONS

SYSTEM

DISASSEMBLING

TROUBLESHOOTING

E/G

OPT.

INDEX

Book Code No. Distribution Year-Month			Title	Index No.
S5PA0105E01 2015-10		SPECIFICATIONS	OUTLINE	1
S5PW0243E02 2018-03			SPECIFICATIONS	2
S5PW0340E02 2018-03			ATTACHMENT DIMENSIONS	3
S5PX1111E01 2015-10		MAINTENANCE	TOOLS	11
S5PX1219E01 2015-10			STANDARD MAINTENANCE TIME SCHEDULE	12
S5PW1340E01 2015-10			MAINTENANCE STANDARD AND TEST PROCEDURE	13
S5PX2119E02 2018-03		SYSTEM	MECHATRO CONTROL (OPT.)	21
S5PW2243E02 2018-03			HYDRAULIC SYSTEM	22
S5PX2319E01 2015-10			ELECTRIC SYSTEM	23
S5PW2443E02 2018-03			COMPONENTS SYSTEM	24
S5PX2519E01 2015-10			AIR-CONDITIONER SYSTEM	25
—				
S5PA3105E01 2015-10		DISASSEMBLING	DISASSEMBLING & ASSEMBLING	31
S5PW3240E01 2015-10			ATTACHMENT	32
S5PW3343E02 2018-03			UPPER STRUCTURE	33
S5PW3440E01 2015-10			TRAVEL SYSTEM	34
—				
S5PX4211E02 2018-03		TROUBLESHOOTING	HYDRAULIC SYSTEM	42
S5PS4314E01 2015-10			ELECTRIC SYSTEM	43
S5PW4431E02 2015-10			ENGINE	44
S5PS4613E01 2015-10			BY ERROR CODES	46
—				
S5PX5112E01 2015-10		E/G	ENGINE	51
—				
PW15-50001~ PW15054180~			APPLICABLE MACHINES	

33 25 1
42 34 2
51 43 11 3
44 12
21 13
46 22
31 23
32 24

NOTE:

This Manual is prepared as a technical material in which the information necessary for the maintenance and repairing services of our hydraulic excavators are collected, and is categorized into 7 Chapters, Specification, Maintenance, System, Disassembly, Troubleshooting, Engine, and Installation Procedures for Optional Attachment.

- The Chapter "Specification" describes the specifications for entire machine and material, which are instructive for replacement and repairing of attachments.
- The Chapter "Maintenance" describes the material, which is helpful for maintenance service and adjustments for entire machine.
- The Chapter "System" describes the operating system like hydraulic system, electric system, components, and so on.
- The Chapter "Disassembly" describes the removal and installing of assembly mounted on the upper structure and undercarriage, and the assembling and disassembling of the associated hydraulic equipment.
- The Chapter "Troubleshooting" describes how to find the fault equipment.
- The Chapter "Engine" describes the engines making use of the "Maintenance Manual" provided by the suppliers.
- The Chapter "Installation Procedures for Optional Attachment" describes the supplements added on request as required.

This Manual may be properly revised due to the improvement of products, modification of specifications, etc. And there are cases where the system on actual machine and a part of the contents of this manual may differ due to the variations of specification by countries. For the section in which the description is hardly understood, contact our distributor.

The number is assigned to every part handled in this Manual on account of the description, but the parts, which cannot be supplied as service parts are contained. Therefore, the order must be placed with respective formal number with due confirmation on the Parts Manual for applicable machine.

<https://www.ebooklibonline.com>

Hello dear friend!

Thank you very much for reading.

Enter the link into your browser.

The full manual is available for immediate download.

<https://www.ebooklibonline.com>

1. OUTLINE

TABLE OF CONTENTS

1.1 GENERAL PRECAUTIONS FOR REPAIRS	1-3
1.1.1 PREPARATION BEFORE DISASSEMBLING	1-3
1.1.2 SAFETY IN DISASSEMBLING AND ASSEMBLING	1-3
1.1.3 DISASSEMBLING AND ASSEMBLING HYDRAULIC EQUIPMENT	1-4
1.1.4 ELECTRICAL EQUIPMENT	1-6
1.1.5 HYDRAULIC PARTS	1-7
1.1.6 WELDING REPAIR	1-7
1.1.7 ENVIRONMENTAL MEASURE	1-7
1.2 INTERNATIONAL UNIT CONVERSION SYSTEM (Based on MARKS' STANDARD HANDBOOK FOR MECHANICAL ENGINEERS)	1-8

[1. OUTLINE]

Issue	Date of Issue	Applicable Machines	Remarks
First Edition	June, 2009	E10SR : PA03-05001~	S5PA0105E01 (NHK-EUR)
↑	December, 2013	SK27SR-5 : PV13-34084~	↑ (EUR)
↑	January, 2014	SK50P-6 : PS03-05001~	↑ (SE Asia)
↑	April, 2014	SK55SRX-6 : PS03-05001~	↑ (EUR)
↑	May, 2014	SK35SR-6E : PX17-40001~	↑ (North America)
↑	June, 2014	SK35SR-6 : PX16-30001~	↑ (OCE)
↑	↑	SK45SRX-6 : PH08-10001~	↑ (OCE)
↑	↑	SK30SR-6 : PW15-50001~	↑ (OCE)
↑	↑	SK35SR-6 : PX16-30001~	↑ (SE Asia)
↑	July, 2014	SK35SR-6E : PX17-40001~	↑ (KOR)
↑	↑	SK28SR-6 : PD03-05001~	↑ (OCE)
↑	↑	SK30SR-6E : PW16-80001~	↑ (KOR)
↑	October, 2014	SK35SR-5 : PX15-23941~	↑ (TUR)
↑	↑	SK55SRX-6 : PS03-05674~	↑ (TUR)
↑	February, 2015	SK60-8 : LE10-H1001~	↑ (Thailand)
↑	June, 2015	SK55SRX-6E : PS04-10001~	↑ (KOR)
↑	October, 2015	SK55SRX-6 : PS03-06936~	↑ (EUR)
↑	↑	SK55SRX-6 : PS03-05001~	↑ (Latin America)
↑	↑	SK30SR-6 : PW15-50001~	↑ (EUR)

The copyright of this manual belongs to KOBELCO CONSTRUCTION MACHINERY CO., LTD.

Copy, reproduction, distribution, and delivery (including these actions on the Internet) of all or part of this manual are prohibited without permission of KOBELCO CONSTRUCTION MACHINERY CO., LTD.

This manual is intended to provide instructions for repair, maintenance, and adjustment of the machine, sold directly or indirectly by KOBELCO CONSTRUCTION MACHINERY CO., LTD. or Kobelco Construction Machinery Europe B.V. and any use other than that purpose will not be allowed.

Also, all or part of this manual cannot be transferred, sold, or lent to a third person without permission of KOBELCO CONSTRUCTION MACHINERY CO., LTD.

1.1 GENERAL PRECAUTIONS FOR REPAIRS

1.1.1 PREPARATION BEFORE DISASSEMBLING



(1) Understanding operating procedure

Read OPERATOR'S MANUAL carefully to understand the operating procedure.

(2) Cleaning machines

Remove soil, mud, and dust from the machine before carrying it into the service shop to prevent loss of work efficiency, damage of parts, and difficulty in rust prevention and dust protection while reassembling.

(3) Inspecting machines

Identify the parts to be disassembled before starting work, determine the disassembling procedure by yourself considering the workshop situations etc., and request procurement of necessary parts in advance.

(4) Recording

Record the following items for communication and prevention of recurring malfunction.

1. Inspection date and place.
2. Model name, applicable machine number, and hour meter read.
3. Trouble condition, place and cause.
4. Visible oil leakage, water leakage and damage.
5. Clogging of filters, oil level, oil quality, oil contamination and loosening of connections.
6. Result of consideration if any problem exists based on the operation rate per month calculated from hour meter indication after the last inspection date.

(5) Arrangement and cleaning in service shop

1. Tools required for repair work.
2. Prepare space to place the disassembled parts.
3. Prepare oil containers for draining oil etc.

1.1.2 SAFETY IN DISASSEMBLING AND ASSEMBLING



- (1) Wear appropriate clothes with long sleeves, safety shoes, safety helmet and protective glasses.
- (2) Suspend warning tag "DO NOT OPERATE" from the doorknob or the operating lever, and have a preliminary meeting before starting work.
- (3) Stop the engine before starting inspection and maintenance to prevent the operator being caught in machine.
- (4) Identify the location of a first-aid kit and a fire extinguisher, and also where to make contact in a state of emergency.
- (5) Choose a hard, level and safe place, and place the attachment on the ground securely.
- (6) Use a lifter such as a crane to remove heavy parts (20 kg [45 lbs] or more) from the machine.

[1. OUTLINE]

- (7) Use proper tools, and replace or repair defective tools.
- (8) Support the machine and attachment with supports or blocks if the work is performed in the lifted condition.

1.1.3 DISASSEMBLING AND ASSEMBLING HYDRAULIC EQUIPMENT



(1) Removing hydraulic equipment

1. Before disconnecting pipes, release the hydraulic pressure of the system, or open the return side cover and take out the filter.
2. Carefully drain oil of the removed pipes into a containers without spilling on the floor.
3. Apply plugs or caps on the pipe ends to avoid oil spillage and dust intrusion.
4. Clean off the external surface of the equipment before disassembling, and drain hydraulic and gear oil before placing it on the workbench.

(2) Disassembling hydraulic equipment

1. Do not disassemble, reassemble or modify the hydraulic equipment without the permission of the manufacturer, who is not responsible for the performance and function of the product after modification.
2. When disassembling and reassembling for unavoidable reason, refer the work to qualified personnel who have the specific knowledge or completed the parts service training.
3. Provide matching marks to facilitate reassembling work.
4. Before starting the work, read the manual of disassembling procedure, if it is provided, and decide whether the work can be performed by yourself.
5. Use the special jig and tools without fail if they are specified.
6. If it is hard to remove a part according to the procedure, do not try it by force but investigate the cause.
7. Place the removed parts in order and attach tags to facilitate the reassembling.
8. Note the location and quantity of parts commonly applied to multiple locations.

(3) Inspecting parts

1. Ensure that the disassembled parts are free from seizure, interference and uneven contact.
2. Measure and record wear condition of parts and clearance.
3. If the problem is found in a part, repair or replace it with a new one.

(4) Reassembling hydraulic equipment

1. Turn ON the ventilation fan or open windows to maintain good ventilation prior to starting the cleaning of parts.
2. Perform rough and finish cleaning before assembling.
3. Remove washing oil by air and apply clean hydraulic or gear oil for assembling.
4. Always replace the removed O-rings, backup rings and oil seals with new ones by applying grease in advance.
5. Remove dirt and moisture from and perform degreasing on the surface where liquid gasket to be applied.
6. Remove rust preventive agent from the new parts before use.
7. Fit bearings, bushings and oil seals using special jigs.
8. Assemble the parts utilizing matching marks.
9. Ensure all the parts are completely assembled after the work.

(5) Installing hydraulic equipment

1. Ensure hydraulic oil and lubricant are properly supplied.
2. Perform air bleeding when :
 - a. Hydraulic oil changed
 - b. Parts of suction side piping replaced
 - c. Hydraulic pump installed
 - d. Slewing motor installed
 - e. Travel motor installed
 - f. Hydraulic cylinder installed
3. Perform air bleeding of the hydraulic pump and slewing motor after loosening the upper drain plug, starting the engine and keep it in low idle condition.
Complete the air bleeding when seeping of hydraulic oil is recognized, and tightly plug.
4. Perform air bleeding of the travel motor and the hydraulic cylinders by running the engine for more than 5 minutes at low speed without load.
5. Perform air bleeding of pilot line by performing a series of digging, slewing and travel.
6. Check hydraulic oil level after placing the attachment to the oil check position, and replenish oil if necessary.

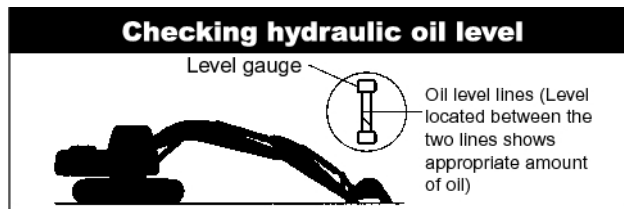
**WARNING**

Operation of the hydraulic equipment without filling hydraulic oil or lubricant or without performing air bleeding will result in damage to the equipment.

WARNING

Do not allow the hydraulic cylinder to bottom on the stroke end just after the maintenance.

1.1.4 ELECTRICAL EQUIPMENT

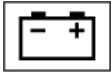

- (1) Do not disassemble electrical equipment.
- (2) Handle it carefully not to drop and give a shock.
- (3) Turn the key OFF prior to connecting and disconnecting work.
- (4) Disconnect the connector by holding it and pressing the lock. Do not pull the wire to apply force to the caulking portion.
- (5) Connect the connector and ensure it is completely locked.
- (6) Turn the key OFF prior to touching the terminal of starter or generator.
- (7) Remove the ground (earth) terminal of battery when handling tools around the battery or its relay.
- (8) Do not splash water on the electrical equipment and connectors during machine washing.
- (9) Check for moisture adhesion inside the waterproof connector after pulling it out, since it is hard to remove moisture from the connector.
If moisture adhesion is found, dry it completely before the connection.



Battery electrolyte is hazardous.

Battery electrolyte is dilute sulfuric acid. Exposure of skin or eyes to this liquid will cause burning or loss of eyesight.

If the exposure occurs, take the following emergency measures and seek the advice of a medical specialist.

-When skin exposed :

Wash with water and soap sufficiently.

-When eyes exposed :

Immediately wash away with city water continuously for more than 10 minutes.

-When a large amount of the liquid flows out :

Neutralize with sodium bicarbonate or wash away with city water.

-When swallowed :

Drink a large amount of milk or water.

-When clothes exposed:

Immediately undress and wash.

1.1.5 HYDRAULIC PARTS



(1) O-ring

- Ensure O-rings have elasticity and are not damaged before use.
- Use the appropriate O-rings. O-rings are made of various kinds of materials having different hardness to apply to a variety of parts, such as the part for moving or fixed portion, subjected to high pressure, and exposed to corrosive fluid, even if the size is same.
- Fit the O-rings without distortion and bend.
- Always handle floating seals as a pair.

(2) Flexible hose (F hose)

- Use the appropriate parts. Different parts are used depending on the working pressure even the size of fitting and the total length of the hose is same.
- Tighten the fitting at the specified torque.
Ensure no kink, tension, interference nor oil leakage is recognized.

1.1.6 WELDING REPAIR

- (1) Refer repair welding to qualified personnel according to the appropriate procedure.
- (2) Disconnect the ground (earth) cable of the battery before starting the repair.
Failure to do so will cause damage to the electrical equipment.
- (3) Move away the articles in advance that may cause fire if exposed to sparks.
- (4) Before starting the repair of the attachment, do not fail to cover the plated surface of the piston rod with flameproof sheet to prevent it from being exposed to sparks.

1.1.7 ENVIRONMENTAL MEASURE

- (1) Run the engine at the place that is sufficiently ventilated.
- (2) Industrial waste disposal
Dispose of the following parts according to the relevant regulations :
Waste oil and waste container
Battery
- (3) Precautions for handling hydraulic oil
Exposure of eyes to hydraulic oil will cause inflammation. Wear protective glasses before handling to avoid an accident. If an eye is exposed to the oil, take the following emergency measures :
-When an eye exposed :
Immediately wash away with city water sufficiently till stimulative feeling vanishes.
-When swallowed :
Do not let vomit, and receive medical treatment immediately.
-When skin exposed:
Wash with water and soap sufficiently.
- (4) Others
Use replacement parts and lubricants authorized as the manufacturer's genuine parts.

1.2 INTERNATIONAL UNIT CONVERSION SYSTEM (Based on MARKS' STANDARD HANDBOOK FOR MECHANICAL ENGINEERS)

Introduction

Although this manual includes International System of Unit and Foot-Pound System of Units, if you need SI unit, refer to the following international system of units.

Given hereinafter is an excerpt of the units that are related to this manual.

1. Etymology of SI Unites

French: Le Systeme International d' Unites

English: International System of Units

2. Construction of SI Unit System

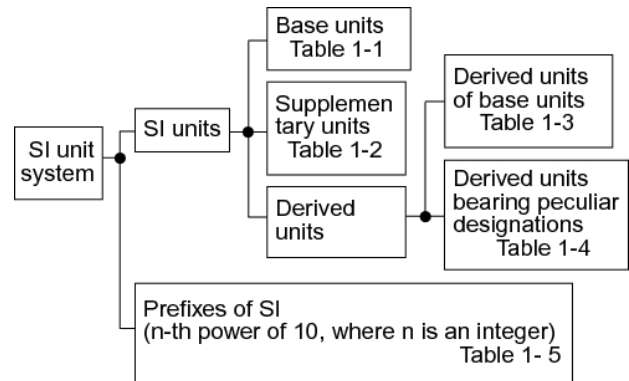

(1) Base units

Table 1-1

QUANTITY	UNIT	SYMBOL
Length	meter	m
Mass	kilogram	kg
Time	second	s
Electric current	ampere	A
Thermodynamic temperature	kelvin	K
Amount of substance	mol	mol
Luminous intensity	candela	cd

(2) Supplementary units

Table 1-2

QUANTITY	UNIT	SYMBOL
Plane angle	radian	rad
Solid angle	steradian	sr

(3) Derived Units

Table 1-3

QUANTITY	UNIT	SYMBOL
Area	square meter	m ²
Volume	cubic meter	m ³
Velocity	meter per second	m/s
Acceleration	meter per second squared	m/s ²
Density	kilogram per cubic meter	kg/m ³

(4) Derived Units bearing Peculiar Designations

Table 1-4

QUANTITY	UNIT	SYMBOL	FORMULA
Frequency	hertz	Hz	1/s
Force	newton	N	kg • m/s ²
Pressure and Stress	pascal	Pa	N/m ²
Energy, Work and Quantity of heat	joule	J	N•m
Power	watt	W	J/s
Quantity of electricity	coulomb	C	A•s
Electric potential difference, Voltage, and Electromotive force	volt	V	W/A
Quantity of static electricity and Electric capacitance	farad	F	C/V
Electric resistance	ohm	Ω	V/A
Celcius temperature	celcius degree or degree	°C	(t+273.15)K
Illuminance	lux	lx	l m/m ²

(5) Prefixes of SI

Table 1-5

PREFIX	SYMBOL	MULTIPLICATION FACTORS
giga	G	10^9
mega	M	10^6
kilo	k	10^3
hecto	h	10^2
deca	da	10
deci	d	10^{-1}
centi	c	10^{-2}
milli	m	10^{-3}
micro	μ	10^{-6}
nano	n	10^{-9}
pico	p	10^{-12}

(6) Unit Conversion

Table 1-6

QUANTITY	Gravitational	SI	CONVERSION FACTOR
Mass	kg	kg	
Force	kgf	N	1 kgf=9.807 N
Torque	kgf•m	N•m	kgf•m=9.807 N•m
Pressure	kgf/cm ²	MPa	1 kgf/cm ² =0.09807 MPa
Motive Power	PS	kW	1 PS=0.7355 kW
Revolution	rpm	min ⁻¹	r/min *1

*1 Units that are allowed to use.

2. SPECIFICATIONS

TABLE OF CONTENTS

2.1 COMPONENTS NAME	2-3
2.2 MACHINE DIMENSIONS	2-4
2.3 SPECIFICATIONS AND PERFORMANCE	2-5
2.4 MACHINE & COMPONENTS WEIGHT (DRY)	2-7
2.5 TRANSPORTATION	2-8
2.5.1 LOADING MACHINE ON A TRAILER	2-8
2.5.2 TRANSPORTATION DIMENSION AND WEIGHT OF ATTACHMENT	2-9
2.6 TYPE OF CRAWLER SHOES	2-10
2.7 TYPE OF BUCKET	2-11
2.8 ENGINE SPECIFICATIONS	2-12
2.8.1 SPECIFICATIONS	2-12
2.8.2 ENGINE PERFORMANCE CURVE	2-13

[2. SPECIFICATIONS]

Issue	Date of Issue	Applicable Machines	Remarks
First Edition	October, 2015	SK30SR-6 : PW15-50001-	S5PW0243E01 (EUR)
↑	September, 2016	SK30SR-6 : PW15-50001-	↑ (KCM-Mid. East & Afr.)
Revision	March, 2018	SK30SR-6 : PW15-50001-	S5PW0243E02 (EUR)

The copyright of this manual belongs to KOBELCO CONSTRUCTION MACHINERY CO., LTD.

Copy, reproduction, distribution, and delivery (including these actions on the Internet) of all or part of this manual are prohibited without permission of KOBELCO CONSTRUCTION MACHINERY CO., LTD.

This manual is intended to provide instructions for repair, maintenance, and adjustment of the machine, sold directly or indirectly by KOBELCO CONSTRUCTION MACHINERY CO., LTD. or Kobelco Construction Machinery Europe B.V. and any use other than that purpose will not be allowed.

Also, all or part of this manual cannot be transferred, sold, or lent to a third person without permission of KOBELCO CONSTRUCTION MACHINERY CO., LTD.

2.1 COMPONENTS NAME

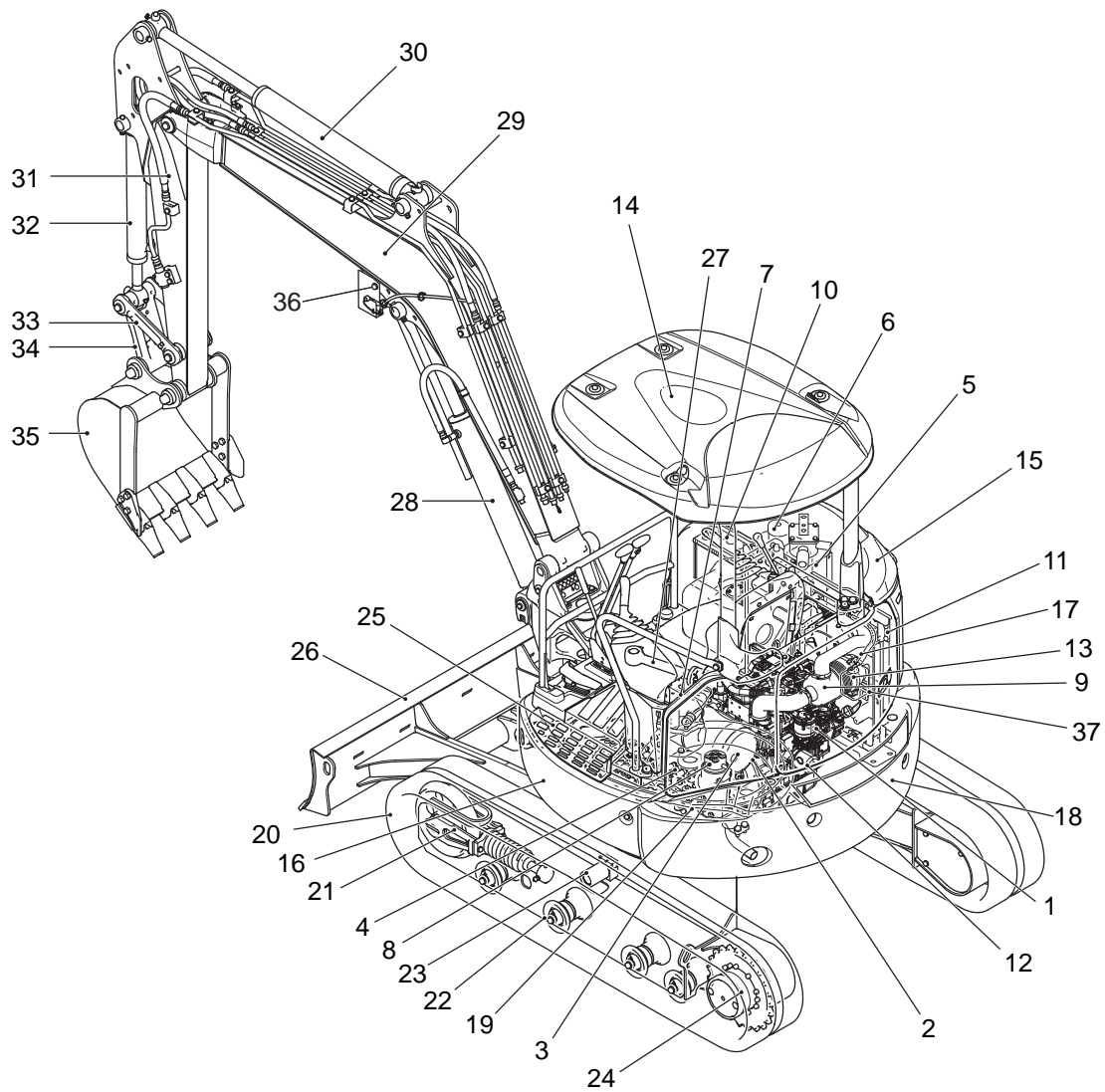

Item	Name	Item	Name	Item	Name
1	Engine	14	Canopy	27	Swing cylinder
2	Hydraulic pump	15	Right side cover	28	Boom cylinder
3	Muffler	16	Guard	29	Boom
4	Control valve	17	Engine hood	30	Arm cylinder
5	Hydraulic oil tank	18	Counterweight	31	Arm
6	Fuel tank	19	Swing bearing	32	Bucket cylinder
7	Swing motor	20	Rubber track shoe	33	Idler link
8	Swivel joint	21	Idler Assembly	34	Bucket link
9	Air cleaner	22	Lower roller	35	Bucket
10	Battery	23	Upper roller	36	Light
11	Radiator	24	Travel motor	37	Fuel cooler
12	Oil filter	25	Dozer cylinder		
13	Reserve tank	26	Dozer		

[2. SPECIFICATIONS]

2.2 MACHINE DIMENSIONS

(1) SK30SR-6 (CANOPY)

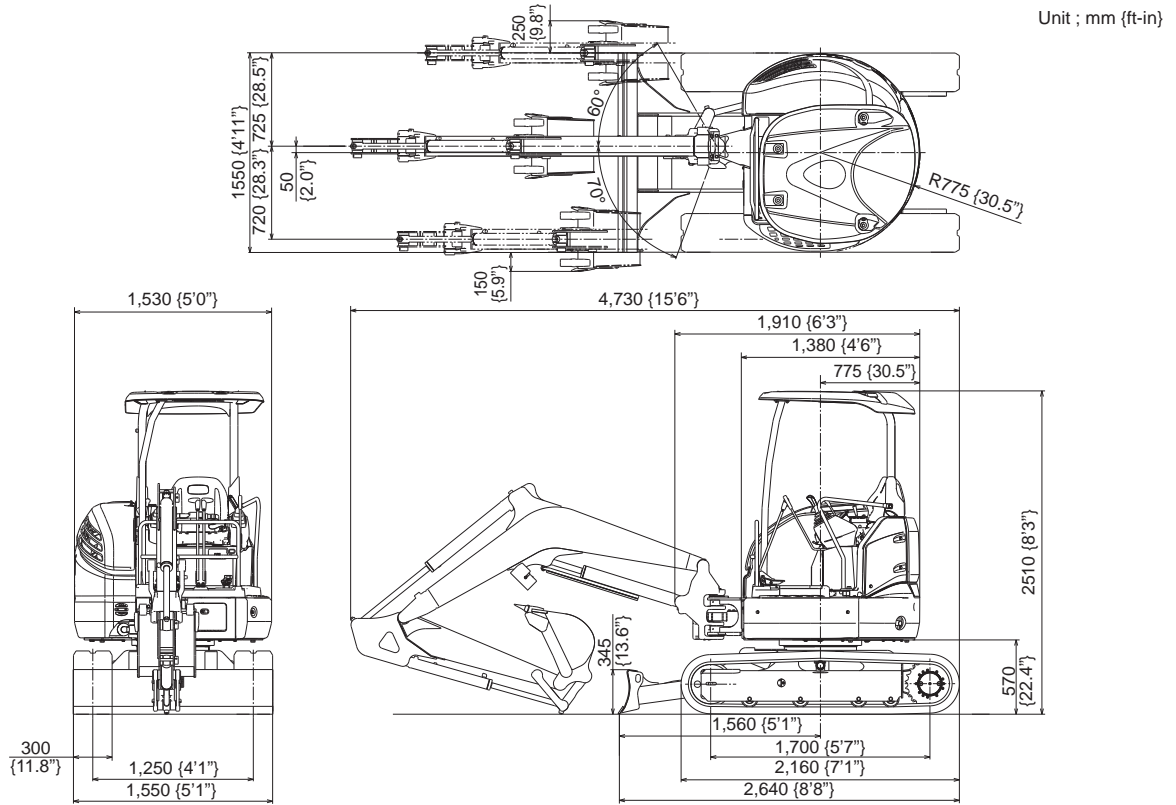

(2) SK30SR-6 (CAB)

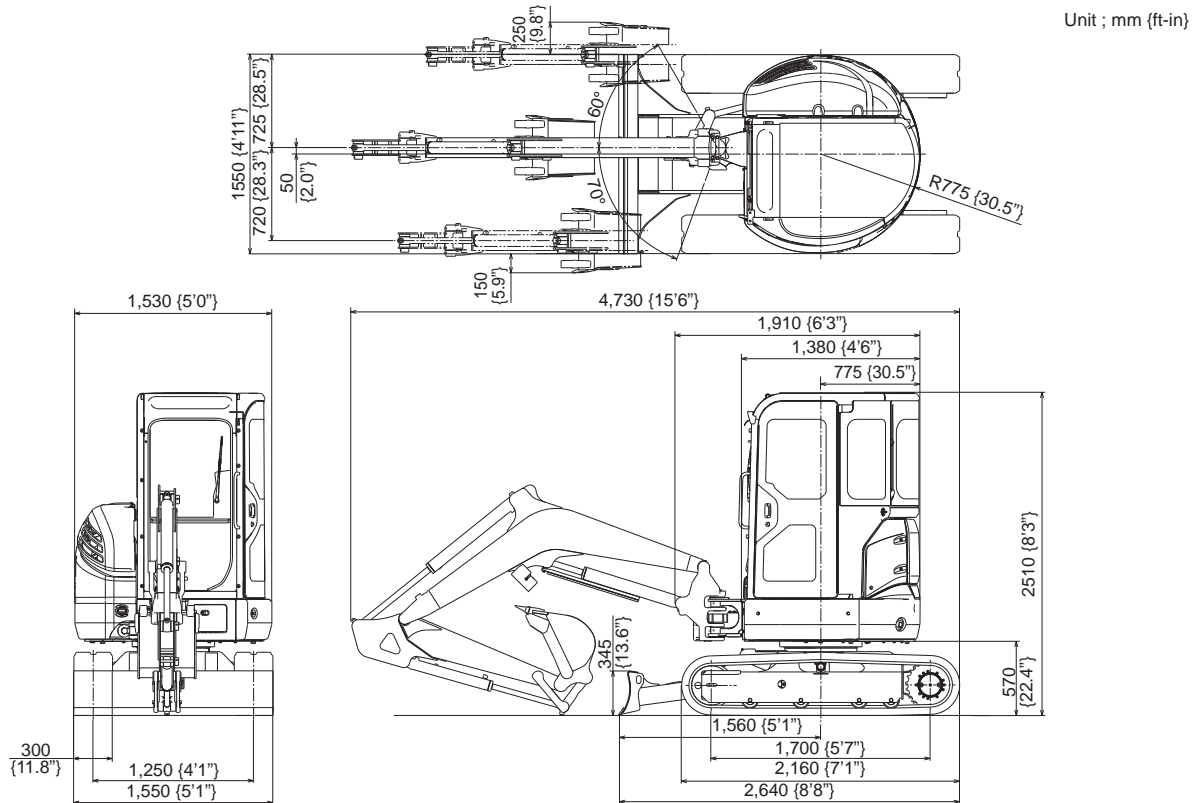

2.3 SPECIFICATIONS AND PERFORMANCE

SPEED AND GRADEABILITY

Model	SK30SR-6							
	CANOPY				CAB			
	Rubber shoe		Iron shoe (OPT)		Rubber shoe		Iron shoe (OPT)	
Slewing Speed	min ⁻¹							8.4
Travel Speed	Low (1st)		High (2nd)		Low (1st)		High (2nd)	
	2.5 (1.6)		4.4 (2.7)		2.5 (1.6)		4.2 (2.6)	
Gradeability	% (degree)							58(30)

ENGINE

Model (YANMAR)	3TNV82A-B		
Type	Water-cooled, 4-cycle type Swirl chamber type diesel engine		
Number of cylinders-Bore X Stroke	3 - 82 dia. mm X 84 mm (3.23 in X 3.31 in)		
Total Displacement	L 1.331 (81.2 cu-in)		
Output Rating	kW/min ⁻¹ (PS/rpm) Net 18.1/2,400 (23.3/2,400) (ISO 14396 : without fan)		
Maximum Torque	N-m/min ⁻¹ (lbf-ft/rpm) Net 79.4/1,440 (57.3/1,440) (ISO 14396 : without fan)		
Starting Motor	V X kW 12 X 1.7		
Generator	V X A 12 X 55		

HYDRAULIC COMPONENTS

Hydraulic Pump	Variable displacement axial piston + gear pump
Hydraulic Motor	Axial piston
Hydraulic Motor w/Reducer (Travel)	2-Axial piston, 2-Speed motor
Control Valve	10-spool multiple control valve
Cylinder (Boom, Arm, Swing, Bucket, Dozer)	Double action cylinder
Return Filter	Safety valve containing/Filter Type ($\beta 10 \geq 8 \mu$)

SIDE DIGGING & DOZER

Type	Boom swing by hydraulic cylinder	
Boom Swing Angle	Right	60 degrees
	Left	70 degrees
Stroke of Dozer (above/below)	mm (in) 395 / 320 (15.6/12.6) (PW15-50001-52631)	
	470 / 400 (18.5/15.7) (PW15-52632-)	

[2. SPECIFICATIONS]

WEIGHT

Machine Weight	kg (lb)	CANOPY		CAB	
		Rubber shoe	Iron shoe	Rubber shoe	Iron shoe
		3,230 (7120)	3,320 (7320)	3,380 (7450)	3,470 (7650)
Upper slewing body	kg (lb)	2,055 (4530)	<--	2,220 (4900)	<--
Travel system	kg (lb)	1,180 (2600)	1,270 (2800)	1,180 (2600)	1,270 (2800)
Attachment (Boom+STD Arm+STD Bucket)	kg (lb)	419 (924)		<--	
Oil & Water	kg (lb)	80 (175)		<--	



Suggest:

For more complete manuals. Please go to the home page.

<https://www.ebooklibonline.com>

If the above button click is invalid. Please download this document first, and then click the above link to download the complete manual.

Thank you so much for reading

2.4 MACHINE & COMPONENTS WEIGHT (DRY)

Unit ; kg (lb)

MODEL	SK30SR-6			
	RUBBER SHOE		IRON SHOE	
	CANOPY	CAB	CANOPY	CAB
COMPLETE MACHINE	3,230 (7120)	3,380 (7450)	3,320 (7320)	3,470 (7650)
UPPER FRAME ASSEMBLY (ASSY OF FOLLOWINGS)	2,055 (4530)	2,220 (4900)	2,055 (4530)	2,220 (4900)
UPPER FRAME	410 (904)	<--	<--	<--
CANOPY / CAB	73 (161)	216 (476)	73 (161)	216 (476)
ENGINE	150 (331)	<--	<--	<--
HYDRAULIC PUMP	21 (46)	<--	<--	<--
RADIATOR	3 (7)	<--	<--	<--
HYDRAULIC TANK	30 (66)	<--	<--	<--
FUEL TANK	4 (9)	<--	<--	<--
BOOM SWING BRACKET	77 (170)	<--	<--	<--
BOOM SWING CYLINDER	30 (66)	<--	<--	<--
SLEWING MOTOR	35 (77)	<--	<--	<--
CONTROL VALVE	25 (55)	<--	<--	<--
COUNTERWEIGHT	327 (721)	<--	<--	<--
GUARD - BONNET	87 (192)	<--	<--	<--
BOOM CYLINDER	34 (75)	<--	<--	<--
LOWER FRAME ASSEMBLY (ASSY OF FOLLOWINGS)	1,180 (2600)	<--	1,270 (2800)	<--
LOWER FRAME	359 (792)	<--	<--	<--
SLEWING BEARING	43 (95)	<--	<--	<--
TRAVEL MOTOR	36X2 (79X2)	<--	<--	<--
LOWER ROLLER	9X8 (20X8)	<--	<--	<--
FRONT IDLER	24X2 (53X2)	<--	<--	<--
IDLER ADJUSTER	14X2 (31X2)	<--	<--	<--
SPROCKET	11X2 (24X2)	<--	<--	<--
300mm (11.8") RUBBER CRAWLER SHOE	146X2 (321X2)	<--	-	-
IRON SHOE	-	-	192X2 (423X2)	<--
SWIVEL JOINT	22 (49)	<--	<--	<--
DOZER	168 (370)	<--	<--	<--
DOZER CYLINDER	23 (51)	<--	<--	<--
ATTACHMENT ASSEMBLY (ASSY OF FOLLOWINGS)	419 (924)	<--	<--	<--
BOOM ASSEMBLY	219 (483)	<--	<--	<--
BOOM	123 (271)	<--	<--	<--
ARM CYLINDER	34 (75)	<--	<--	<--
ARM ASSEMBLY	124 (273)	<--	<--	<--
ARM	65 (143)	<--	<--	<--
BUCKET CYLINDER	23 (51)	<--	<--	<--
BUCKET LINK	10 (22)	<--	<--	<--
IDLER LINK	4X2 (9X2)	<--	<--	<--
BUCKET ASSEMBLY (STD)	76 (168)	<--	<--	<--
FLUIDS	80 (176)	<--	<--	<--
HYDRAULIC OIL	40 (88)	<--	<--	<--
FUEL	35 (77)	<--	<--	<--
COOLANT	5 (11)	<--	<--	<--

2.5 TRANSPORTATION

2.5.1 LOADING MACHINE ON A TRAILER

1. Keep trailer bed clean. Put chocks against truck wheels.
 2. Use a ramp or loading deck. Ramps must be strong enough, have a low angle, and correct height. Load and unload machine on a level surface.
 3. Travel machine onto ramps slowly. Center the machine over the trailer.
 4. Lower all attachment.
 5. Stop engine. Remove key from switch.
-

 WARNING

Do not put chains over or against hydraulic lines or hoses.

6. Fasten machine to trailer with chains or cables.
During transportation, the bucket or attachments may hit the canopy or the cab. Therefore, set the machine in the transporting position by observing following points:
 - a. Extend the bucket cylinder fully.
 - b. Extend the arm cylinder fully.
 - c. Lower the boom.
 - d. If machine cannot be transported with arm cylinder fully extended, remove bucket or attachment and extend arm cylinder.

<https://www.ebooklibonline.com>

Hello dear friend!

Thank you very much for reading.

Enter the link into your browser.

The full manual is available for immediate download.

<https://www.ebooklibonline.com>