

# HYDRAULIC EXCAVATOR

## SHOP MANUAL      model      **SK27SR-5**

### INDEX

1	SPECIFICATIONS
2	MAINTENANCE
3	SYSTEM
4	DISASSEMBLING
5	TROUBLESHOOTING
6	ENGINE
7	INSTALLATION PROCEDURES FOR OPTIONAL ATTACHMENT
8	SUPPORTING DATA

**KOBELCO**

Book Code No. **S5PV0013E01**

Book Code No. Distribution Year–Month			Title	Index No.
S5PW0108E01 2007-9		<b>SPECIFICATIONS</b>	OUTLINE	<b>1</b>
S5PV0213E01 2007-9			SPECIFICATIONS	<b>2</b>
S5PV0313E01 2007-9			ATTACHMENT DIMENSIONS	<b>3</b>
S5PV1105E01 2007-9		<b>MAINTENANCE</b>	TOOLS	<b>11</b>
S5PV1205E01 2007-9			STANDARD MAINTENANCE TIME TABLE	<b>12</b>
S5PV1313E01 2007-9			MAINTENANCE STANDARD AND TEST PROCEDURES	<b>13</b>
—				
S5PV2213E01 2007-9		<b>SYSTEM</b>	HYDRAULIC SYSTEM	<b>22</b>
S5PV2313E01 2007-9			ELECTRICAL SYSTEM	<b>23</b>
S5PV2413E01 2007-9			COMPONENTS SYSTEM	<b>24</b>
—				
—				
S5PV3105E01 2007-9		<b>DISASSEMBLING</b>	GENERAL DISASSEMBLY & ASSEMBLY	<b>31</b>
S5PV3213E01 2007-9			ATTACHMENT	<b>32</b>
S5PV3313E01 2007-9			UPPER SLEWING STRUCTURE	<b>33</b>
S5PV3413E01 2007-9			TRAVEL SYSTEM	<b>34</b>
—				
S5PW4209E01 2007-9		<b>TROUBLESHOOTING</b>	HYDRAULIC SYSTEM	<b>42</b>
S5PW4309E01 2007-9			ELECTRICAL SYSTEM	<b>43</b>
S5PW4408E01 2007-9			ENGINE	<b>44</b>
S5PW5108E01 2007-9		<b>E/G</b>	ENGINE	<b>51</b>
—		<b>OPT.</b>		
—				
S5PV7113E01 2007-9		<b>DATA</b>	SUPPORTING DATA	<b>71</b>
PV13-33001~			APPLICABLE MACHINES	

---

## NOTE:

This Manual is prepared as a technical material in which the information necessary for the maintenance and repairing services of our hydraulic excavators are collected, and is categorized into 7 Chapters, Specification, Maintenance, System, Disassembly, Troubleshooting, Engine, and Installation Procedures for Optional Attachment.

- The Chapter "Specification" describes the specifications for entire machine and material, which are instructive for replacement and repairing of attachments.
- The Chapter "Maintenance" describes the material, which is helpful for maintenance service and adjustments for entire machine.
- The Chapter "System" describes the operating system like hydraulic system, electric system, components, and so on.
- The Chapter "Disassembly" describes the removal and installing of assembly mounted on the upper structure and undercarriage, and the assembling and disassembling of the associated hydraulic equipment.
- The Chapter "Troubleshooting" describes how to find the fault equipment.
- The Chapter "Engine" describes the engines making use of the "Maintenance Manual" provided by the suppliers.
- The Chapter "Installation Procedures for Optional Attachment" describes the supplements added on request as required.

This Manual may be properly revised due to the improvement of products, modification of specifications, etc. And there are cases where the system on actual machine and a part of the contents of this manual may differ due to the variations of specification by countries. For the section in which the description is hardly understood, contact our distributor.

The number is assigned to every part handled in this Manual on account of the description, but the parts, which cannot be supplied as service parts are contained. Therefore, the order must be placed with respective formal number with due confirmation on the Parts Manual for applicable machine.

**<https://www.ebooklibonline.com>**

Hello dear friend!

Thank you very much for reading.

Enter the link into your browser.

The full manual is available for immediate download.

**<https://www.ebooklibonline.com>**

# 1. OUTLINE

## TABLE OF CONTENTS

1.1	GENERAL PRECAUTIONS FOR REPAIRS .....	1-3
1.1.1	PREPARATION BEFORE DISASSEMBLING .....	1-3
1.1.2	SAFETY IN DISASSEMBLING AND ASSEMBLING .....	1-3
1.1.3	DISASSEMBLING AND ASSEMBLING HYDRAULIC EQUIPMENT .....	1-3
1.1.4	ELECTRICAL EQUIPMENT .....	1-4
1.1.5	HYDRAULIC PARTS .....	1-5
1.1.6	WELDING REPAIR.....	1-5
1.1.7	ENVIRONMENTAL MEASURE .....	1-5
1.2	INTERNATIONAL UNIT CONVERSION SYSTEM (Based on MARKS' STANDARD HANDBOOK FOR MECHANICAL ENGINEERS) .....	1-6

## 1. OUTLINE

Issue	Data of Issue	Applicable Machines	Remarks
First Edition	April, 2007	SK30SR-3 : PW13-42001~ SK35SR-3 : PX14-17001~	S5PW0108E01 (KCM North America) SZ
↑	↑	SK27SR-3 : PV12-31001~	↑ (KCM North America) SZ
↑	August, 2007	SK30SR-5 : PW14-45001~ SK35SR-5 : PX15-20001~	↑ (KCM North America) K
↑	September, 2007	↑	↑ (KCM S.E.ASIA&OCE) K
↑	↑	SK27SR-5 : PV13-33001~	↑ (KCM North America) K

## 1.1 GENERAL PRECAUTIONS FOR REPAIRS

### 1.1.1 PREPARATION BEFORE DISASSEMBLING



- (1) Understanding operating procedure  
Read OPERATOR'S MANUAL carefully to understand the operating procedure.
- (2) Cleaning machines  
Remove soil, mud, and dust from the machine before carrying it into the service shop to prevent loss of work efficiency, damage of parts, and difficulty in rust prevention and dust protection while reassembling.
- (3) Inspecting machines  
Identify the parts to be disassembled before starting work, determine the disassembling procedure by yourself considering the workshop situations etc., and request procurement of necessary parts in advance.
- (4) Recording  
Record the following items for communication and prevention of recurring malfunction.
  - 1) Inspection date and place
  - 2) Model name, applicable machine number, and hour meter read
  - 3) Trouble condition, place and cause.
  - 4) Visible oil leakage, water leakage and damage
  - 5) Clogging of filters, oil level, oil quality, oil contamination and loosening of connections
  - 6) Result of consideration if any problem exists based on the operation rate per month calculated from hour meter indication after the last inspection date.
- (5) Arrangement and cleaning in service shop
  - 1) Tools required for repair work.
  - 2) Prepare space to place the disassembled parts.
  - 3) Prepare oil containers for draining oil etc.

### 1.1.2 SAFETY IN DISASSEMBLING AND ASSEMBLING



- (1) Wear appropriate clothes with long sleeves, safety shoes, safety helmet and protective glasses.

- (2) Suspend warning tag "DO NOT OPERATE" from the doorknob or the operating lever, and have a preliminary meeting before starting work.
- (3) Stop the engine before starting inspection and maintenance to prevent the operator being caught in machine.
- (4) Identify the location of a first-aid kit and a fire extinguisher, and also where to make contact in a state of emergency.
- (5) Choose a hard, level and safe place, and place the attachment on the ground securely.
- (6) Use a lifter such as a crane to remove heavy parts (20 kg [45 lbs] or more) from the machine.
- (7) Use proper tools, and replace or repair defective tools.
- (8) Support the machine and attachment with supports or blocks if the work is performed in the lifted condition.

### 1.1.3 DISASSEMBLING AND ASSEMBLING HYDRAULIC EQUIPMENT



- (1) Removing hydraulic equipment
  - 1) Before disconnecting pipes, release the hydraulic pressure of the system, or open the return side cover and take out the filter.
  - 2) Carefully drain oil of the removed pipes into a containers without spilling on the floor.
  - 3) Apply plugs or caps on the pipe ends to avoid oil spillage and dust intrusion.
  - 4) Clean off the external surface of the equipment before disassembling, and drain hydraulic and gear oil before placing it on the workbench.
- (2) Disassembling hydraulic equipment
  - 1) Do not disassemble, reassemble or modify the hydraulic equipment without the permission of the manufacturer, who is not responsible for the performance and function of the product after modification.
  - 2) When disassembling and reassembling for unavoidable reason, refer the work to qualified personnel who have the specific knowledge or completed the parts service training.
  - 3) Provide matching marks to facilitate reassembling work.
  - 4) Before starting the work, read the manual of disassembling procedure, if it is provided, and decide whether the work can be performed by yourself.

## 1. OUTLINE

- 5) Use the special jig and tools without fail if they are specified.
  - 6) If it is hard to remove a part according to the procedure, do not try it by force but investigate the cause.
  - 7) Place the removed parts in order and attach tags to facilitate the reassembling.
  - 8) Note the location and quantity of parts commonly applied to multiple locations.
- (3) Inspecting parts
- 1) Ensure that the disassembled parts are free from seizure, interference and uneven contact.
  - 2) Measure and record wear condition of parts and clearance.
  - 3) If the problem is found in a part, repair or replace it with a new one.
- (4) Reassembling hydraulic equipment
- 1) Turn ON the ventilation fan or open windows to maintain good ventilation prior to starting the cleaning of parts.
  - 2) Perform rough and finish cleaning before assembling.
  - 3) Remove washing oil by air and apply clean hydraulic or gear oil for assembling.
  - 4) Always replace the removed O-rings, backup rings and oil seals with new ones by applying grease in advance.
  - 5) Remove dirt and moisture from and perform degreasing on the surface where liquid gasket to be applied.
  - 6) Remove rust preventive agent from the new parts before use.
  - 7) Fit bearings, bushings and oil seals using special jigs.
  - 8) Assemble the parts utilizing matching marks.
  - 9) Ensure all the parts are completely assembled after the work.
- (5) Installing hydraulic equipment
- 1) Ensure hydraulic oil and lubricant are properly supplied.
  - 2) Perform air bleeding when:
    1. Hydraulic oil changed
    2. Parts of suction side piping replaced
    3. Hydraulic pump installed
    4. Slewing motor installed
    5. Travel motor installed
    6. Hydraulic cylinder installed



**Operation of the hydraulic equipment without filling hydraulic oil or lubricant or without performing air bleeding will result in damage to the equipment.**

- 3) Perform air bleeding of the hydraulic pump and slewing motor after loosening the upper drain plug, starting the engine and keep it in low idle condition.  
Complete the air bleeding when seeping of hydraulic oil is recognized, and tightly plug.
- 4) Perform air bleeding of the travel motor and the hydraulic cylinders by running the engine for more than 5 minutes at low speed without load.



**Do not allow the hydraulic cylinder to bottom on the stroke end just after the maintenance.**

- 5) Perform air bleeding of pilot line by performing a series of digging, slewing and travel.
- 6) Check hydraulic oil level after placing the attachment to the oil check position, and replenish oil if necessary.

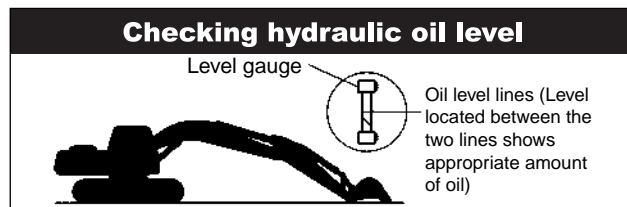

### 1.1.4 ELECTRICAL EQUIPMENT

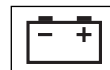

- (1) Do not disassemble electrical equipment.
- (2) Handle it carefully not to drop and give a shock.
- (3) Turn the key OFF prior to connecting and disconnecting work.
- (4) Disconnect the connector by holding it and pressing the lock. Do not pull the wire to apply force to the caulking portion.
- (5) Connect the connector and ensure it is completely locked.
- (6) Turn the key OFF prior to touching the terminal of starter or generator.
- (7) Remove the ground (earth) terminal of battery when handling tools around the battery or its relay.

- (8) Do not splash water on the electrical equipment and connectors during machine washing.
- (9) Check for moisture adhesion inside the waterproof connector after pulling it out, since it is hard to remove moisture from the connector.  
If moisture adhesion is found, dry it completely before the connection.



**Battery electrolyte is hazardous.**

**Battery electrolyte is dilute sulfuric acid. Exposure of skin or eyes to this liquid will cause burning or loss of eyesight.**

**If the exposure occurs, take the following emergency measures and seek the advice of a medical specialist.**

- **When skin exposed:**  
Wash with water and soap sufficiently.
- **When eyes exposed:**  
Immediately wash away with city water continuously for more than 10 minutes.
- **When a large amount of the liquid flows out:**  
Neutralize with sodium bicarbonate or wash away with city water.
- **When swallowed:**  
Drink a large amount of milk or water.
- **When clothes exposed:**  
Immediately undress and wash.

### 1.1.5 HYDRAULIC PARTS



- (1) O-ring
  - Ensure O-rings have elasticity and are not damaged before use.
  - Use the appropriate O-rings. O-rings are made of various kinds of materials having different hardness to apply to a variety of parts, such as the part for moving or fixed portion, subjected to high pressure, and exposed to corrosive fluid, even if the size is same.
  - Fit the O-rings without distortion and bend.
  - Always handle floating seals as a pair.
- (2) Flexible hose (F hose)
  - Use the appropriate parts. Different parts are used depending on the working pressure even the size of fitting and the total length of the hose is same.

- Tighten the fitting at the specified torque. Ensure no kink, tension, interference nor oil leakage is recognized.

### 1.1.6 WELDING REPAIR

- (1) Refer repair welding to qualified personnel according to the appropriate procedure.
- (2) Disconnect the ground (earth) cable of the battery before starting the repair.  
Failure to do so will cause damage to the electrical equipment.
- (3) Move away the articles in advance that may cause fire if exposed to sparks.
- (4) Before starting the repair of the attachment, do not fail to cover the plated surface of the piston rod with flameproof sheet to prevent it from being exposed to sparks.

### 1.1.7 ENVIRONMENTAL MEASURE

- (1) Run the engine at the place that is sufficiently ventilated.
- (2) Industrial waste disposal  
Dispose of the following parts according to the relevant regulations:  
Waste oil and waste container  
Battery
- (3) Precautions for handling hydraulic oil  
Exposure of eyes to hydraulic oil will cause inflammation. Wear protective glasses before handling to avoid an accident. If an eye is exposed to the oil, take the following emergency measures:
  - When an eye exposed:  
Immediately wash away with city water sufficiently till stimulative feeling vanishes.
  - When swallowed:  
Do not let vomit, and receive medical treatment immediately.
  - When skin exposed:  
Wash with water and soap sufficiently.
- (4) Others  
Use replacement parts and lubricants authorized as the manufacturer's genuine parts.

# 1. OUTLINE

## 1.2 INTERNATIONAL UNIT CONVERSION SYSTEM (Based on MARKS' STANDARD HANDBOOK FOR MECHANICAL ENGINEERS)

### Introduction

Although this manual includes International System of Unit and Foot-Pound System of Units, if you need SI unit, refer to the following international system of units. Given hereinafter is an excerpt of the units that are related to this manual.

#### 1. Etymology of SI Unites

French : Le Systeme International d' Unites

English : International System of Units

#### 2. Construction of SI Unit System

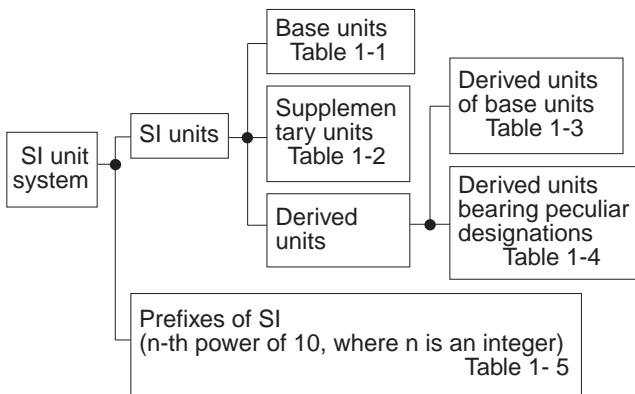

#### (1) Base units

**Table 1-1**

QUANTITY	UNIT	SYMBOL
Length	meter	m
Mass	kilogram	kg
Time	second	s
Electric current	ampere	A
Thermodynamic temperature	kelvin	K
Amount of substance	mol	mol
Luminous intensity	candela	cd

#### (2) Supplementary units

**Table 1-2**

QUANTITY	UNIT	SYMBOL
Plane angle	radian	rad
Solid angle	steradian	sr

#### (3) Derived Units

**Table 1-3**

QUANTITY	UNIT	SYMBOL
Area	square meter	m <sup>2</sup>
Volume	cubic meter	m <sup>3</sup>
Velocity	meter per second	m/s
Acceleration	meter per second squared	m/s <sup>2</sup>
Density	kilogram per cubic meter	kg/m <sup>3</sup>

#### (4) Derived Units bearing Peculiar Designations

**Table 1-4**

QUANTITY	UNIT	SYMBOL	FORMULA
Frequency	hertz	Hz	1/s
Force	newton	N	kg • m/s <sup>2</sup>
Pressure and Stress	pascal	Pa	N/m <sup>2</sup>
Energy, Work and Quantity of heat	joule	J	N•m
Power	watt	W	J/s
Quantity of electricity	coulomb	C	A•s
Electric potential difference, Voltage, and Electromotive force	volt	V	W/A
Quantity of static electricity and Electric capacitance	farad	F	C/V
Electric resistance	ohm	Ω	V/A
Celcius temperature	celcius degree or degree	°C	(t+273.15)K
Illuminance	lux	lx	l m/m <sup>2</sup>

## (5) Prefixes of SI

**Table 1-5**

PREFIX	SYMBOL	MULTIPLICATION FACTORS
giga	G	$10^9$
mega	M	$10^6$
kilo	k	$10^3$
hecto	h	$10^2$
deca	da	10
deci	d	$10^{-1}$
centi	c	$10^{-2}$
milli	m	$10^{-3}$
micro	$\mu$	$10^{-6}$
nano	n	$10^{-9}$
pico	p	$10^{-12}$

## (6) Unit Conversion

**Table 1-6**

QUANTITY	Gravitational	SI	CONVERSION FACTOR
Mass	kg	kg	
Force	kgf	N	1 kgf=9.807 N
Torque	kgf•m	N•m	kgf•m=9.807 N•m
Pressure	kgf/cm <sup>2</sup>	MPa	1 kgf/cm <sup>2</sup> =0.09807 MPa
Motive Power	PS	kW	1 PS=0.7355 kW
Revolution	rpm	min <sup>-1</sup>	r/min *1

\*1 Units that are allowed to use.

[MEMO]

## 2. SPECIFICATIONS

### TABLE OF CONTENTS

2.1	COMPONENTS NAME.....	2-3
2.2	MACHINE DIMENSIONS.....	2-4
2.3	SPECIFICATIONS AND PERFORMANCE .....	2-5
2.4	MACHINE & COMPONENTS WEIGHT (DRY).....	2-6
2.5	TRANSPORTATION.....	2-7
2.6	TYPE OF CRAWLER SHOES .....	2-9
2.7	TYPE OF BUCKET .....	2-9
2.8	ENGINE SPECIFICATIONS .....	2-10
2.8.1	SPECIFICATIONS.....	2-10
2.8.2	ENGINE PERFORMANCE CURVE .....	2-11

## 2. SPECIFICATIONS

---

Issue	Data of Issue	Applicable Machines	Remarks
First Edition	September, 2007	SK27SR-5 : PV13-33001~	S5PV0213E01 (KCM North America) K

2.1 COMPONENTS NAME

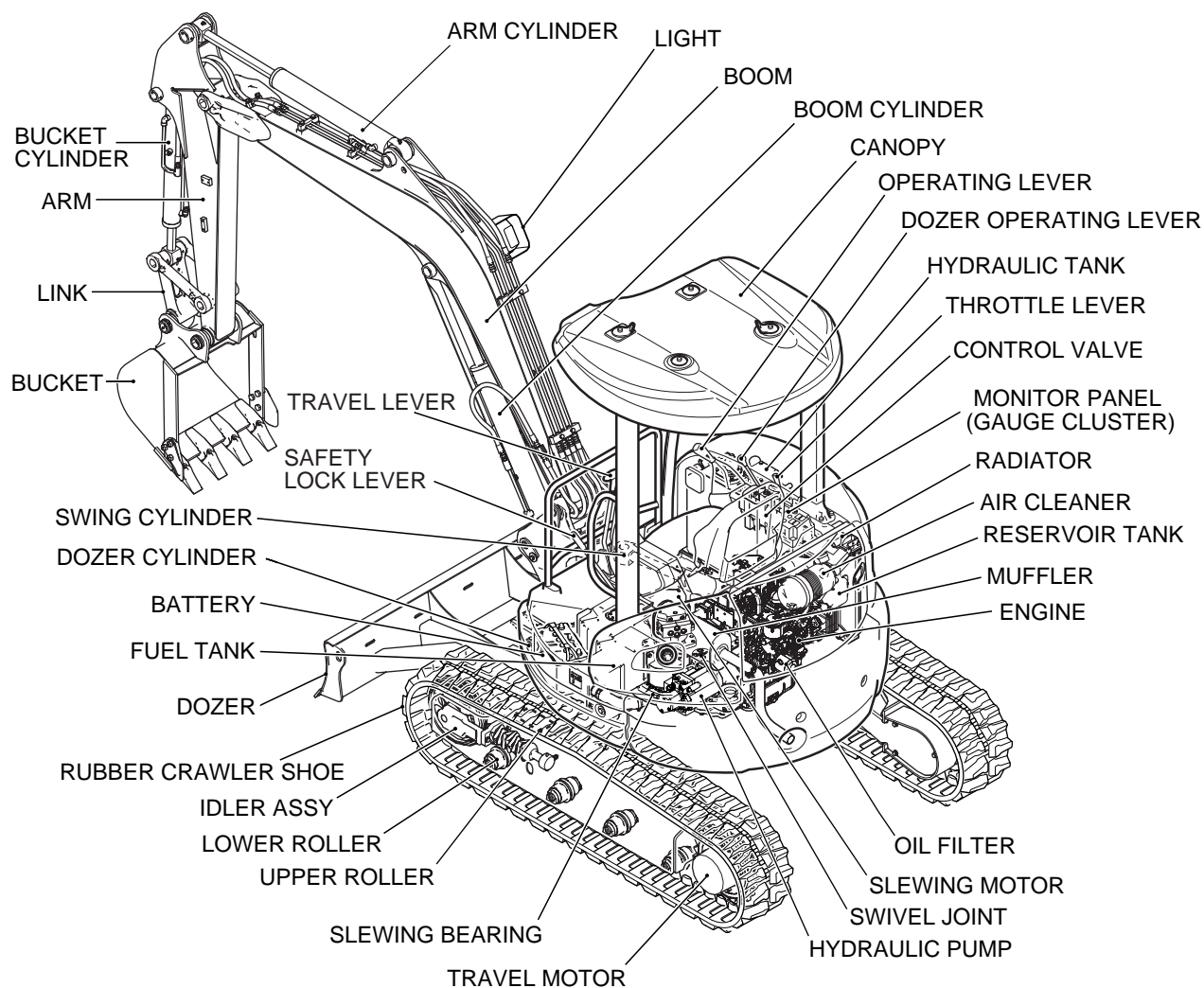

## 2. SPECIFICATIONS

### 2.2 MACHINE DIMENSIONS

Unit: mm (ft•in)

#### (1) SK27SR-5 (CANOPY)

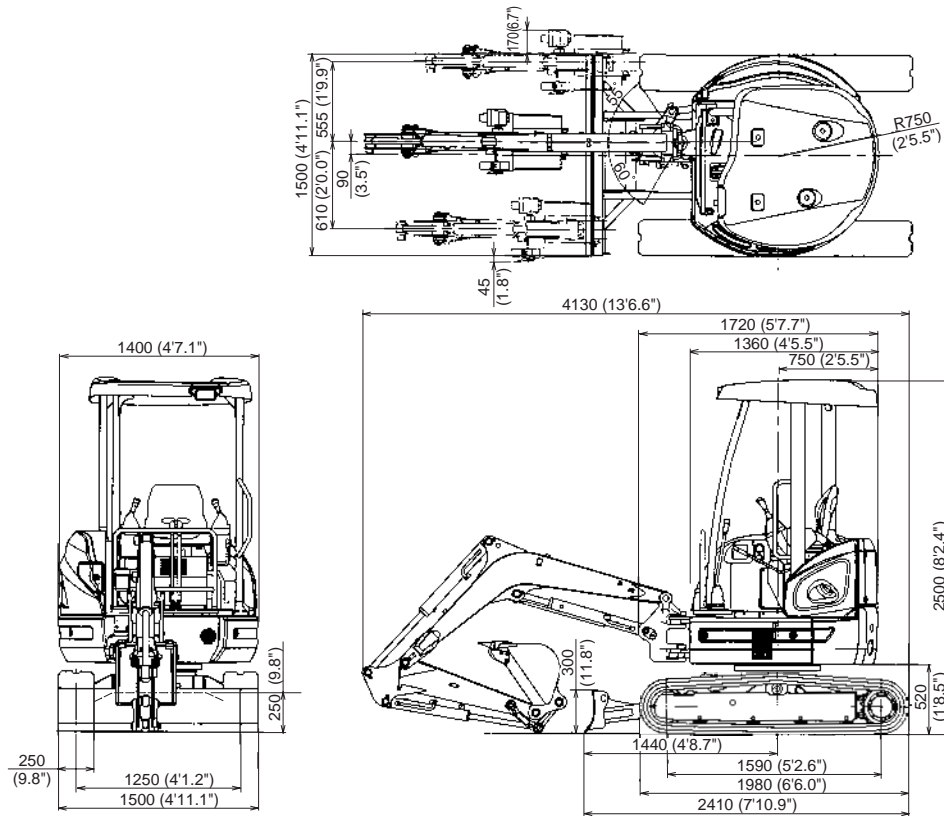

#### (2) SK27SR-5 (CAB)

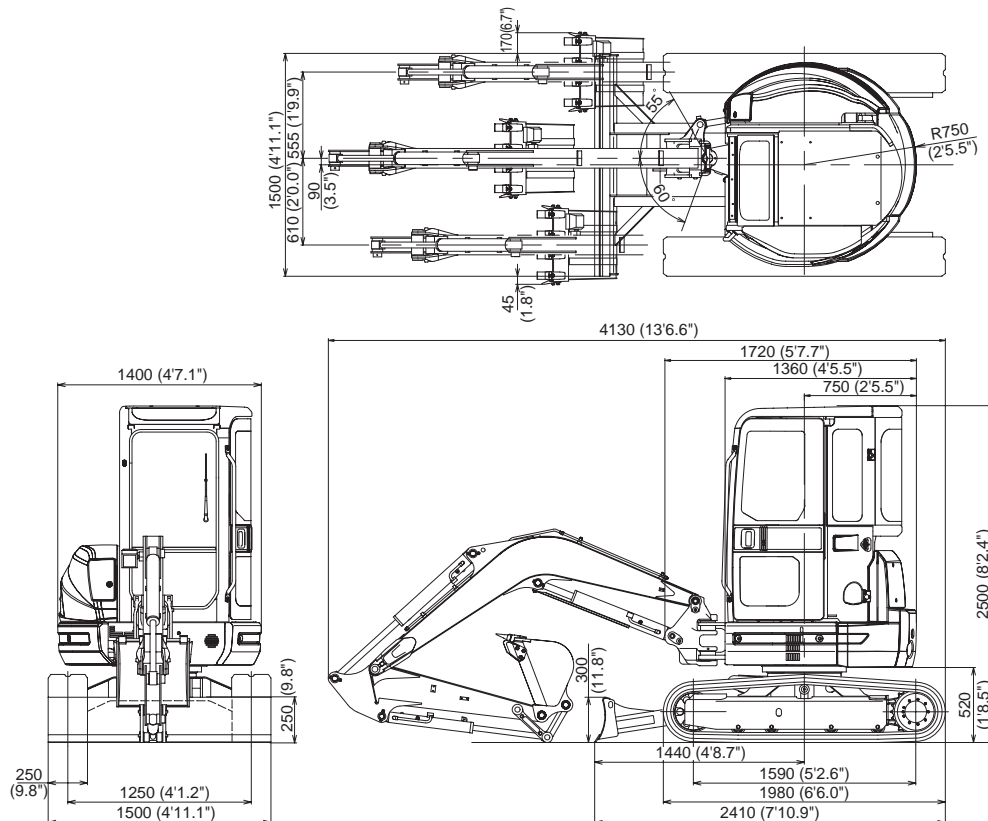

## 2.3 SPECIFICATIONS AND PERFORMANCE

### SPEED AND GRADEABILITY

Model	SK27SR-5				
Applicable Machines	PV13-33001~				
Shoe Type	Rubber shoe		Iron shoe (OPT)		
Slewing Speed	min <sup>-1</sup> {rpm}	8.7 (8.7)			
Travel Speed	km/h (mph)	Low (1st)	High (2nd)	Low (1st)	High (2nd)
		2.3	4.0	2.3	4.0
Gradeability	% (degree)	58(30)			

### ENGINE

Model (YANMAR)	3TNV82A-SYB			
Type	Water-cooled, 4-cycle type Swirl chamber type diesel engine			
Number of cylinders-Bore × Stroke	3 - ø82 mm × 84mm (3.23 in × 3.31 in)			
Total Displacement	L	1.330 (81.2 cu·in)		
Output Rating	kW/min <sup>-1</sup> {PS/rpm}	15.9 / 2,200 (21.6 / 2,200)		
Intermediate Torque (Net)	N·m/min <sup>-1</sup> (lb·ft/rpm)	79.0~86.0/1,320±100 (58.3~63.4/1,320±100)		
Starting Motor	V × kW	12 × 1.7		
Generator	V × A	12 × 40		

### HYDRAULIC COMPONENTS

Hydraulic Pump	Variable displacement axial piston + gear pump			
Hydraulic Motor	Axial piston			
Hydraulic Motor w/Reducer (Travel)	2-Axial piston, 2-Speed motor			
Control Valve	10-spool multiple control valve			
Cylinder (Boom, Arm, Swing, Bucket, Dozer)	Double action cylinder			
Return Filter	Safety valve containing/Filter Type (30μ)			

### SIDE DIGGING & DOZER

Type	Boom swing by hydraulic cylinder		
Boom Swing Angle	Right	55°	
	Left	60°	
Stroke of Dozer (above/below)	mm (in)	445 / 335(17.5/13.2)	

### WEIGHT

Machine Weight	kg (lb)	Rubber shoe	Iron shoe
		2,490 (5490)	2,620 (5780)
Upper slewing body	kg (lb)	1,310 (2890)	←
Travel system	kg (lb)	830 (1830)	960 (2120)
Attachment (Boom+STD Arm+STD Bucket)	kg (lb)	300 (660)	
Oil & Water	kg (lb)	50 (110)	

Note : This figure is calculated with Japanese standard bucket.



**Suggest:**

**For more complete manuals. Please go to the home page.**

**<https://www.ebooklibonline.com>**

**If the above button click is invalid. Please download this document first, and then click the above link to download the complete manual.**

**Thank you so much for reading**

## 2. SPECIFICATIONS

### 2.4 MACHINE & COMPONENTS WEIGHT (DRY)

Unit ; kg (lb)

MODEL	SK27SR-5			
	RUBBER SHOE		IRON SHOE (OPT)	
	CANOPY	CAB	CANOPY	CAB
COMPLETE MACHINE	2,490 (5490)	2,630 (5800)	2,620 (5780)	2,760 (6080)
UPPER FRAME ASSEMBLY (ASSY OF FOLLOWINGS)	1,310 (2890)	1,450 (3200)	1,310 (2890)	1,450 (3200)
UPPER FRAME	265 (584)	←	←	←
CANOPY / CAB	85 (187)	220 (485)	85 (187)	220 (485)
ENGINE	130 (287)	←	←	←
HYDRAULIC PUMP	18 (40)	←	←	←
RADIATOR	3 (7)	←	←	←
HYDRAULIC TANK	30 (66)	←	←	←
FUEL TANK	4 (9)	←	←	←
SWING BRACKET	59 (130)	←	←	←
SWING CYLINDER	23 (51)	←	←	←
SLEWING MOTOR	32 (71)	←	←	←
CONTROL VALVE	24 (53)	←	←	←
COUNTERWEIGHT	290 (639)	←	←	←
GUARD • BONNET	97 (214)	←	←	←
BOOM CYLINDER	24 (53)	←	←	←
LOWER FRAME ASSEMBLY (ASSY OF FOLLOWINGS)	830 (1830)	←	960 (2120)	←
LOWER FRAME	328 (723)	←	←	←
SLEWING BEARING	36 (79)	←	←	←
TRAVEL MOTOR	27 ×2 (60×2)	←	←	←
LOWER ROLLER	6 ×8 (13×8)	←	←	←
FRONT IDLER	17×2 (37×2)	←	←	←
IDLER ADJUSTER	11×2 (24×2)	←	←	←
SPROCKET	5×2 (11×2)	←	←	←
250mm (9.8") RUBBER CRAWLER SHOE	80 (176) ×2	←	—	—
250mm (9.8") IRON SHOE	—	—	147 (324) ×2	←
SWIVEL JOINT	11 (24)	←	←	←
DOZER	117 (260)	←	←	←
DOZER CYLINDER	20 (44)	←	←	←
ATTACHMENT ASSEMBLY (ASSY OF FOLLOWINGS)	300 (662)	←	←	←
BOOM ASSEMBLY	125 (276)	←	←	←
BOOM	88 (194)	←	←	←
ARM CYLINDER	28 (62)	←	←	←
ARM ASSEMBLY	95 (209)	←	←	←
ARM	51 (112)	←	←	←
BUCKET CYLINDER	17 (37)	←	←	←
BUCKET LINK	6 (13)	←	←	←
IDLER LINK	2×2 (4×2)	←	←	←
BUCKET ASSEMBLY (STD)	64 (141)	←	←	←
FLUIDS (ASSY OF FOLLOWINGS)	50 (110)	←	←	←
HYDRAULIC OIL	24 (53)	←	←	←
FUEL	22 (49)	←	←	←
COOLANT	4 (9)	←	←	←

Note : Bucket weight is shown with Japanese standard bucket weight.

## 2.5 TRANSPORTATION

### (1) LOADING MACHINE ON A TRAILER

- 1) Keep trailer bed clean. Put chocks against truck wheels.
- 2) Use a ramp or loading deck. Ramps must be strong enough, have a low angle, and correct height. Load and unload machine on a level surface.
- 3) Travel machine onto ramps slowly. Center the machine over the trailer.
- 4) Lower all attachment.
- 5) Stop engine. Remove key from switch.



**Do not put chains over or against hydraulic lines or hoses.**

- 6) Fasten machine to trailer with chains or cables.

During transportation, the bucket or attachments may hit the canopy or the cab. Therefore, set the machine in the transporting position by observing following points:

1. Extend the bucket cylinder fully.
2. Extend the arm cylinder fully.
3. Lower the boom.
4. If machine cannot be transported with arm cylinder fully extended, remove bucket or attachment and extend arm cylinder.

### (2) TRANSPORTATION DIMENSION AND WEIGHT OF ATTACHMENT

#### 1) BOOM WITH ARM CYLINDER

Model	SK27SR-5
L × H × W mm (ft•in)	2,230 × 775 × 220 (7'3.8" × 2'6.5" × 8.7")
Weight w/Arm cyl. kg (lb)	125 (276)

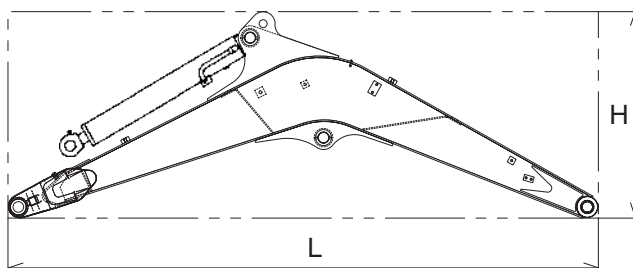

#### 2) ARM & BUCKET (Japanese standard bucket)

Model	SK27SR-5
L × H × W mm (ft•in)	2,050 × 400 × 500 (6'8.7" × 1'3.7" × 1'7.7")
Weight kg (lb)	160 (353)

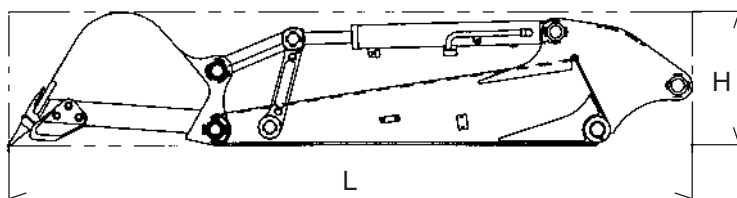

**<https://www.ebooklibonline.com>**

Hello dear friend!

Thank you very much for reading.

Enter the link into your browser.

The full manual is available for immediate download.

**<https://www.ebooklibonline.com>**