

KOBELCO

SERVICE MANUAL
NISSAN DIESEL ENGINE
FD6
FD6T

SMEFDS1E00 NA

Issued 01Apr 88

ENGINE SERVICE MANUAL

MODEL
FD6 & FD6T

Applicable Engine Numbers

FD6

FD6-005001 ~

FD6T

FD6-010001T ~

FOREWORD

This service manual covers repair procedure of the FD6 and FD6T diesel engines. In order for the engine displays 100% performance at all times, and to expand the life of each part, daily inspection and servicing must, of course, be performed according to a plan, but proper overhaul and repair in accordance with the maintenance standards is also vital.

Keep this manual in the shop for everyone engaging in servicing of the engine.

Nissan Diesel reserves the right to make changes for improvement at any time without notice.

Accordingly, some of the descriptions contained in this manual may not be applicable to your particular vehicle.

QUICK REFERENCE INDEX

1. GENERAL

2. DISASSEMBLY JUDGMENT

3. ENGINE DISASSEMBLY
AND REASSEMBLY

4. ENGINE PROPER

5. CYLINDER HEAD AND
VALVE MECHANISM

6. LUBRICATION SYSTEM

7. COOLING SYSTEM

8. FUEL SYSTEM

9. AIR INTAKE AND
EXHAUST SYSTEM

10. ELECTRICAL SYSTEM

11. AUXILIARY EQUIPMENT

12. ENGINE TEST PROCEDURES

13. SERVICE DATA

14. TOOLS

1. GENERAL

GENERAL

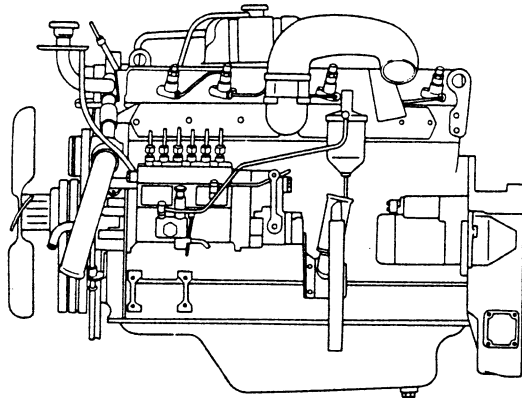

EF1-002

This chapter describes handling cautions of this manual and engine general. Therefore, when repairing FD6 and FD6T engines by using this manual, first read this chapter.

METHOD OF USING THIS MANUAL	1-1
ENGINE SPECIFICATIONS	1-2
LUBRICATIONS AND FUEL	1-4

<https://www.ebooklibonline.com>

Hello dear friend!

Thank you very much for reading.

Enter the link into your browser.

The full manual is available for immediate download.

<https://www.ebooklibonline.com>

METHOD OF USING THIS MANUAL

STANDARDIZATION OF TERMS

ENGINE POSITION

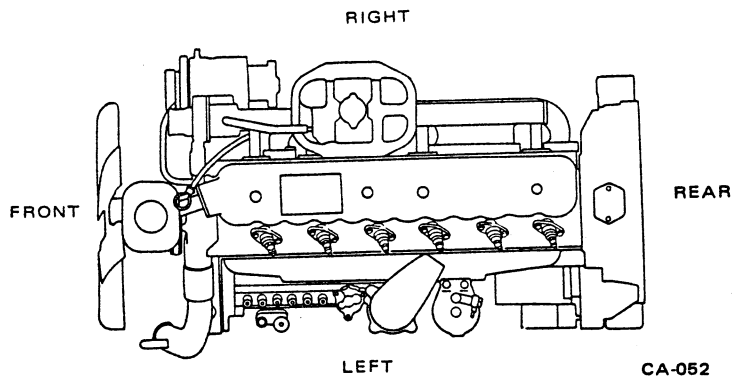

1 mm	0.0394 in.
1 kg	2.205 lb.
1 kgm	7.23 lb. ft.
1 kg/cm ²	14.223 psi.
1 liter	0.220 Imp. gal.
1 liter	0.264 U.S. gal.

$$t (^{\circ}\text{F}) = 32 + \frac{9}{5} T (^{\circ}\text{C})$$

However, the unit of horsepower uses France horsepower.

ABBREVIATION

In this manual, the following abbreviations are used.

O.D.	Outside Diameter
I.D.	Inside Diameter
O.S.	Over Size
U.S.	Under Size
B.T.D.C.	Before Top Dead Center
A.B.D.C.	After Bottom Dead Center
B.B.D.C.	Before Bottom Dead Center
A.T.D.C.	After Top Dead Center
P.T.O.	Power Take Off

MAINTENANCE STANDARD TERMS

Maintenance standard

"Maintenance standard" indicates the standard clearance when parts are assembled or the standard performances of assembly parts.

Repair limit

"Repair limit" indicates that repair is necessary if the clearance between parts or the parts are to meet the values given in the repair limit are to be attained.

Wear limit

"Wear limit" indicates that the part has exceeded the given wear limit and must be replaced.

UNITS

The units of measures used throughout this manual, are in accordance with the metric system. When conversion to the corresponding English units (Foot pound system) is necessary, utilize the following.

USING THIS MANUAL

This manual consists of each chapter. When the trouble points are unclear, refer to chapter 2 "Disassembly-Judgment" and locate the trouble point. Prepare the necessary tools, referring to Chapter 14.

Then, refer to chapter 3 "Engine disassembly" and remount the trouble components, and repair by referring to the chapter 4 "Engine proper" to chapter 11 "Auxiliary equipment" for each component. For check of the engine performance, refer to chapter 12 "Engine test procedures". Moreover, maintenance standards and tightening torque are collected in the chapter 13 "Service data".

ENGINE SPECIFICATIONS

Model		FD6	FD6T		
Type		Diesel			
Cooling system		Water cooled			
Number of cylinders and cylinder configuration		6, in-line			
Number of circles		4			
Type of combustion chamber		Direct fuel injection			
Valve mechanism		Overhead valve, gear-driven			
Type of cylinder liner		Wet			
Bore x stroke [mm]		100 x 120			
Piston total displacement [cc]		5,654			
Compression ratio		17.0 : 1			
Cylinder compression [kg/cm ² (rpm)]		More than 30 (200)			
Number of piston rings	Compression ring	2			
	Oil ring	1			
Intake valve timing	Open	15° B.T.D.C.			
	Closed	47° A.B.D.C.			
Exhaust valve timing	Open	53° B.B.D.C.			
	Closed	9° A.T.D.C.			
Valve clearance [mm]	Intake	0.4			
	Exhaust	0.4			
Fuel system	Ignition system		Compression ignition		
	Fuel injection timing [B.T.D.C.]		15°30'	17°	
	Ignition order		1-4-2-6-3-5		
	Fuel injection pump	Type		Bosch A type	
		Plunger diameter [mm]	9.0	8.5	
		Cam lift [mm]	8.0		
		Governor	Centrifugal		
		Timer	Centrifugal		
	Fuel injection nozzle	Nozzle holder		Flange type	
		Number of injection nozzle		4	
Injection pressure [kg/cm ²]		200	220		

		Model	FD6	FD6T	
Intake and exhaust system	Air cleaner	Type	Cyclone or oil bath		
		Number	1		
	Air heater	Type	Ribbon type		
		Voltage [V] x Current [A] x number	22 x 110 x 1		
	Turbocharger	Type	—	T04B93	
		External dimensions (Length x Width x Height)	—	210 x 220 x 215	
		Max. permissible continuous speed (rpm)	—	125,000	
		Direction of rotation	—	Counterclockwise as viewed from the exhaust turbine side	
		Air volume [kg/min]	—	20	
		Compression ratio	—	3.0	
Lubricating system	Type		Forced circulation		
	Oil pump		Gear pump		
	Oil filter	Fullflow	Paper element		
		By-pass	Paper element		
	Lubrication oil capacity [ℓ]		15		
	Oil cooler		Water cooled flat tube type		
Cooling system	Type		Forced circulation		
	Radiator		Corrugated fin		
	Cooling water capacity (only for the engine)[ℓ]		10		
	Water pump		Centrifugal		
	Thermostat		Wax pellet type		
Electrical system	Charging system	Type	AC, diode-rectified		
		Output [V-A]	24 - 80, 24 - 25 or 24 - 40	24 - 15 or 24 - 25	
		Voltage regulator	Tirill type		
	Starting motor	Type	Shift type		
		Output [V-kW]	24 - 3.5, 24 - 4.5, 24 - 5.0	24 - 4.5 or 24 - 3.5	

LUBRICATIONS AND FUEL

ENGINE OIL

The use of proper engine oil for heavy duty is essential. NISSAN DIESEL engine should be lubricated with oil of a performance level not less than the requirements based on API service classification CD or CC class oil and SAE viscosity grades. However, use classification CD class oil in engines equipped with a turbocharger.

API: American Petroleum Institute
SAE: Society of Automotive Engineers

Recommended class-CD engine oils (ML-L-2104C)

Petroleum Maker	Brand	SAE Viscosity
CALTEX	CALTEX RPM DELO 300 OIL	10W, 20W/20, 30, 40
	CALTEX RPM DELO 400 OIL	15W/40, 20W/20, 10W, 30, 40
TEXACO	URSA OIL LA-3	10W, 20W/20, 30, 40
	TEXACO URSA SUPER PLUS	10W, 15W/40, 20W/20, 30, 40
	TEXACO URSA OIL SUPER 3	10W, 20W/20, 30, 40
ESSO	ESSOLUBE D-3 SERIES	10W, 20W, 30, 40
	ESSOLUBE XD-3	10W, 10W/30, 15W/40, 20W/20, 30, 40
	ESSOLUBE XD-3 EXTRA	10W, 10W/30, 15W/40, 20W/20, 30, 40
MOBIL	MOBIL DELVAC 1300 SERIES	30, 40
GULF	GULF SUPER DUTY MOTOR OIL	10W, 15W/40, 20W/20, 30, 40
SHELL	SHELL RIMULA CT OIL or SHELL RIMULA X OIL	10W, 20W/20, 30, 40
	SHELL MYRINA OIL	15W/40, 20W/20, 30, 40
BP	BP VANELLUS C3	10W, 20W, 30, 40
	BP VANELLUS C3 MULTIGRADE	15W/40
CASTROL	CASTROL OR DEUSOL CRD	10W, 20W, 30, 40
	CASTROL OR DEUSOL RX SUPER	10W, 15W/40, 20W/20, 30, 40
	CASTROL OR DEUSOL CRF	10W, 20W/20, 30, 40
AGIP	AGIP F.1 DIESEL SIGMA	10W, 20W/20, 30, 40
VALVO-LINE	SUPER 1000 S-3 MOTOR OIL OR ALL FLEET MOTOR OIL	10W, 20W, 30, 40
CHEV-ROTON	CHEVRON DELO 300 MOTOR OIL	10W, 20W/20, 30, 40
	CHEVRON DELO 400 MOTOR OIL	10W, 15W/40, 20W/20, 30, 40
VEEDOL	VEEDOL DIESEL HDC	10W, 15W/40, 20W/20, 30, 40
	VEEDOL DIESEL STER	10W, 15W/40, 20W/20, 30, 40

Recommended Viscosity (SAE) Grades

Atmospheric temperature °C	Recommended SAE viscosity	
-18 to +10	10W	10W/30
-7 to +25	20W/20	
-12 to +40	15W/40, 20W/40	
+5 to +40	30	
More than +30	40	

Recommended class-CC engine oils (MIL-L-2104B or MIL-L46152)

Petroleum Maker	Brand	SAE Viscosity
CALTEX	CALTEX RPM DELO 100 OIL	10W, 20W/20, 30, 40
	CALTEX RPM DELO 200 OIL	10W, 10W/30, 20W/20, 20W/40, 30, 40
TEXACO	URSA OIL EXTRA DUTY	10W, 20W/20, 30, 40
	TEXACO HAVOLINE MOTOR OIL	10W, 20W/20, 30, 40
	TEXACO URSATEX	10W/30, 20W/40
ESSO	ESSOLUBE HDX SERIES	10W, 20W, 30, 40
	ESSOLUBE HDX PLUS	10W/30, 15W/40
MOBIL	MOBIL DELVAC 1100 SERIES	10W, 20W/20, 30, 40
	MOBIL DELVAC 1200 SERIES	10W, 20W/20, 30, 40
GULF	GULFLUBE MOTOR OIL XHD	10W, 20W/20, 30, 40
	GULF SUPER DUTY MOTOR OIL	10W, 15W/40, 20W/20, 30, 40
SHELL	SHELL ROTELLA SX OIL	10W, 10W/30, 20W/20, 20W/40, 30, 40
	SHELL ROTELLA TX OIL	10W, 10W/30, 20W/20, 20W/40, 30, 40
BP	BP VANELLUS M	10W, 10W/30, 20W/20, 30, 40
CASTROL	CASTROL OR DEUSOL CRX	10W, 10W/30, 20W/20, 30, 40
AGIP	AGIP F.1 DIESEL GAMMA	10W, 20W/20, 30, 40
VALVO-LINE	HD SUPER HPO MOTOR OIL	10W, 20W, 30, 40
CHEV-ROTON	CHEVRON DELO 100 MOTOR OIL	10W, 20W/20, 30, 40
	CHEVRON DELO 200 MOTOR OIL	10W, 20W/20, 30, 40
VEEDOL	VEEDOL DIESEL HD PLUS	10W, 20W/20, 30, 40
	VEEDOL DIESEL HDB PLUS	10W, 10W/30, 20W/20, 30, 40

BEARING GREASE**(Brand recommended: NLGI No. 2, Li, -Soap base)**

This grease may be used on generator, fan pulley bracket, starting motor, and etc. Be careful of contamination while grease is in storage.

Petroleum Maker	Brand
CALTEX	CALTEX MARFAK MULTIPURPOSE NO. 2
	CALTEX MARFAK ALL PURPOSE NO. 2
TEXACO	TEXACO MARFAK MULTIPURPOSE NO. 2
	TEXACO MARFAK ALL PURPOSE NO. 2
ESSO	ESSO MULTIPURPOSE GREASE
	ESSO RONEX MP
MOBIL	MOBIL GREASE MP
GULF	GULFLEX A
SHELL	SHELL RETINAX A
	SHELL ALVANIA RA
	SHELL ALVANIA EP2
BP	BP ENERGREASE L2
CASTROL	CASTROL LM GREASE
AGIP	AGIP F.1 GREASE 1530
VALVO-LINE	VAL-LITH NO. 2 EP GREASE
	GLO GREASE
CHEV- RON	CHEVRON MULTI-MOTIVE GREASE NO. 2
	CHEVRON POLYUREA EP GREASE NO. 2
VEEDOL	VEEDOL MULTIPURPOSE or ALL PURPOSE GREASE NO. 2

NLGI: National Lubricating Grease Institute

COOLING SYSTEM WATER

Be sure to use clean, soft water such as city water in the cooling system. Do not use hard water such as well water or river water, because such water can easily form scale in the system. Note that scale attached to the water passage in the cooling system (particularly in the radiator) can cause engine overheating.

FUEL

The Nissan Diesel engine is designed to produce power by using light oil as fuel. Do not use any fuel except light oil; otherwise, engine trouble will result.

The light oil should have a cetane number greater than 45, specific gravity of 0.81 to 0.85, boiling point ranging from 180 to 380°C, sulfur content of less than 0.5%, and should prove neutral in a chemical reaction test. It should be clean, possess the proper viscosity, and contain no water or sediment.

CAPACITIES OF UNIT**FD6, FD6T**

Engine oil sump

Total capacity

15 liters

Oil pan capacity

H level 12 liters

L level 9 liters

Cooling system water (only for the engine)

20 liters

2. DISASSEMBLY JUDGMENT

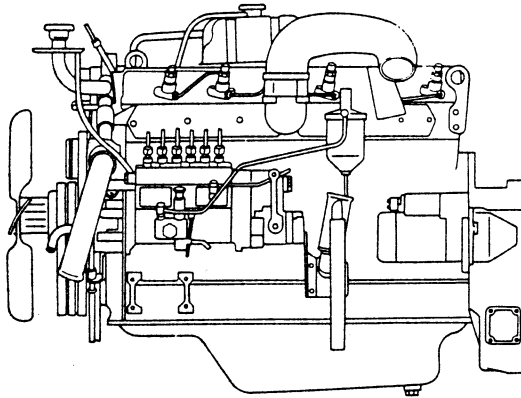

EF1-002

DISASSEMBLY JUDGMENT

This chapter covers the judgment of disassembling the FD engine.

DETERMINING THE NEED FOR ENGINE OVERHAUL	2-1
TROUBLESHOOTING TESTS	2-2
CAUSE OF TROUBLE AND ITS CORRECTION	2-7
DIAGNOSIS GUIDE	2-7

DETERMINING THE NEED FOR ENGINE OVERHAUL

Whether an engine needs overhauling or not is determined by considering various factors including reduction in output, difficulty in starting, deterioration in oil or fuel consumption, reduction in oil pressure, and the increased need for periodic maintenance. It is desirable, however, to judge whether or not the engine actually requires overhauling by conducting various checks, as many of the above factors can often be corrected through minor service operation rather than a complete overhaul.

REDUCTION IN COMPRESSION PRESSURE

The compression pressure of the engine lowers as the cylinder liner, piston, piston rings and valves become worn. If compression pressure drops to the repair limit, the engine must be overhauled.

Compression pressure (Warm engine and engine rpm: 180 to 220)

Maintenance standard

More than 30 kg/cm²

Repair limit

Less than 25.0 kg/cm²

Difference between cylinders

Maintenance standard

Less than 4.0 kg/cm²

DETERIORATION IN FUEL CONSUMPTION (FC)

Deterioration of FC is also attributable to the operating conditions of the vehicle (including road condition, load weight, driving habits) and poor maintenance of parts. Therefore, deterioration of FC is not always a sign that engine overhaul is required. However, if the operating conditions are unchanged from the new car period, it is possible to determine whether or not the engine requires overhauling by using the FC value of the new car period as a reference. If the FC value drops below 60% of the reference value, the engine should be overhauled.

DETERIORATION IN ENGINE OIL CONSUMPTION (OC)

The OC value changes according to various factors including operating conditions of vehicle, quality of engine oil, etc. However, if the OC value drops below 40% of its initial value during the new car period, it can be regarded as a sign that engine overhaul is required. Before making the final decision to overhaul, it is also necessary to check compression pressure, blow-by gas pressure and other

factors, and to thoroughly inspect the engine.

REDUCTION IN ENGINE OIL PRESSURE

If the engine oil pressure drops to the repair limit, the engine including the lubricating system should be overhauled.

**Engine oil pressure
(Oil temperature 70 to 80°C)**

At idling

Maintenance standard

1.0 kg/cm²

Repair limit

Min. 0.5 kg/cm²

At 1,500 rpm

Maintenance standard

3.2 to 4.4 kg/cm²

Repair limit

Min. 2.0 kg/cm²

TROUBLESHOOTING TESTS

MEASURING COMPRESSION PRESSURE

The measurement value of the compression pressure is important in determining the time that engine overhaul is needed. It is therefore necessary to periodically measure and record engine compression pressure.

Compression pressure (Warm engine and engine rpm: 180 to 220)

Maintenance standard

More than 30.0 kg/cm²

Repair limit

Less than 25.0 kg/cm²

Difference between cylinders

Maintenance standard

Max. 4.0 kg/cm²

Examples of trouble

Trouble symptoms that are attributable to incorrect compression pressure are: low engine output, deteriorated oil consumption, deteriorated fuel consumption, emission of white smoke during high speed travelling, difficulty in starting, irregular engine operation, diesel knock, overheating, etc. If compression pressure drops below the repair limit, the cause must be examined, and the engine overhauled.

Factors that may cause reduction in compression pressure

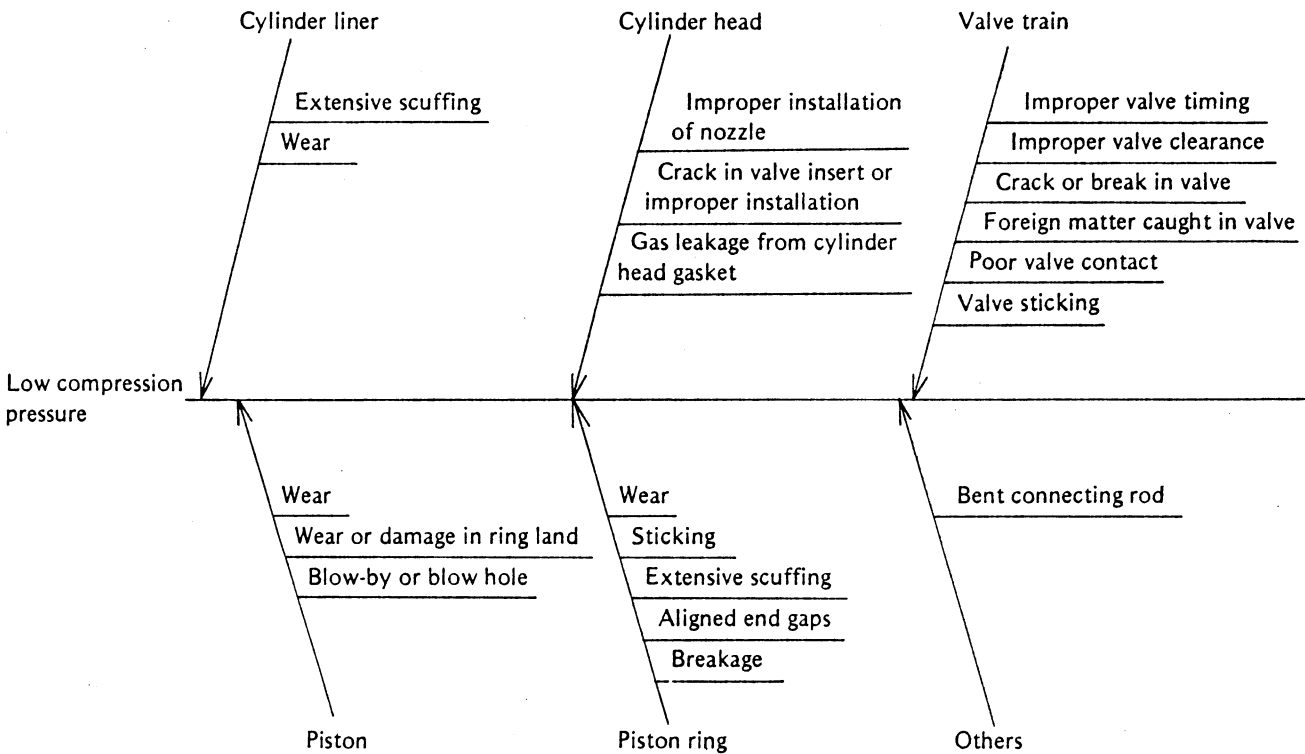

MEASURING BLOW-BY GAS PRESSURE

Measurement of blow-by gas pressure like measurement of compression pressure provides an important information, in deciding whether or not an engine should be overhauled.

Blow-by gas pressure (Warm engine at maximum rpm under no load)
 Maintenance standard
 Max. 12 mmAq

Trouble symptom

Trouble symptoms that are attributable to excessive blow-by gas pressure are: low engine output, deterioration in oil or fuel consumption, emission of white smoke during high speed travelling, difficulty in starting, irregular engine operation, diesel knock, overheating, oil leakage from air breather or other areas, etc. If the blow-by gas pressure exceeds the service standard, compression pressure should also be

measured, and then a decision should be made whether the engine requires overhauling.

Factors that may cause an increase in blow-by gas pressure

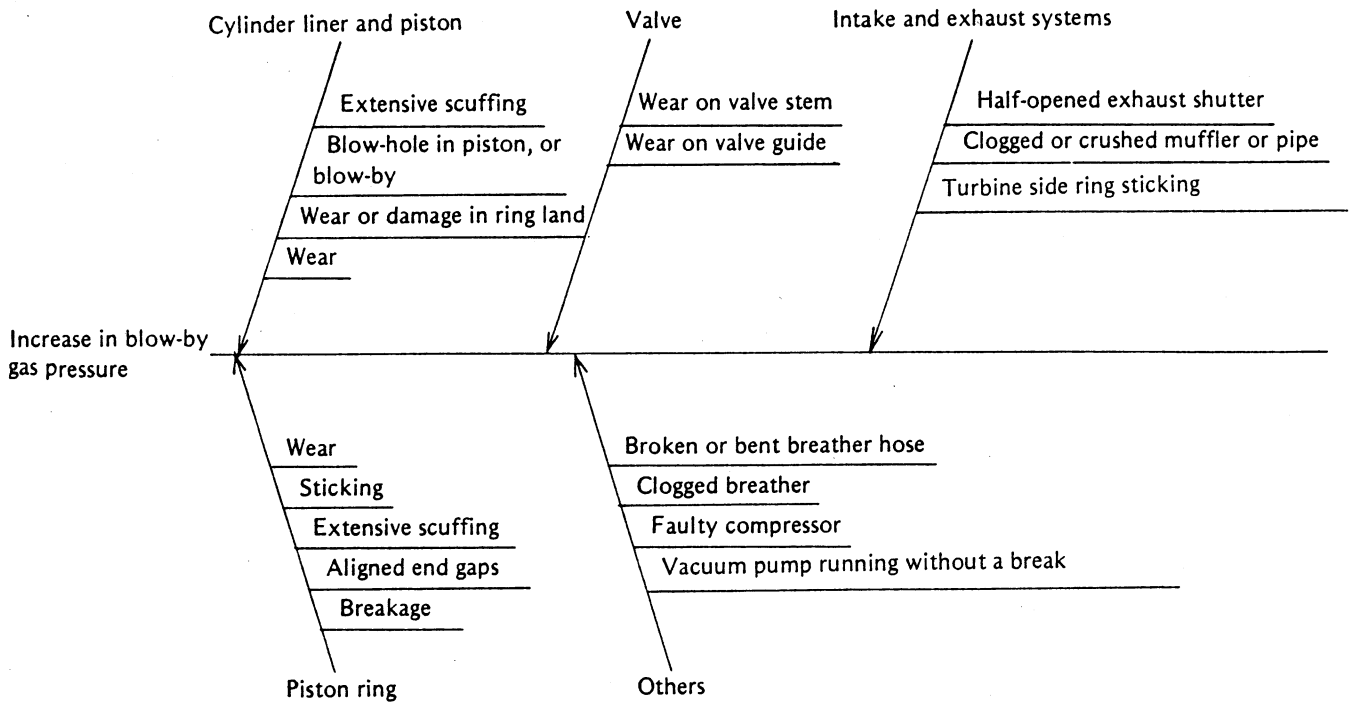

MEASUREMENT OF BOOST PRESSURE

Should the turbocharger become inoperative, boost pressure should be measured to diagnose the intake and exhaust systems.

When engine speed is no-load max. running (Warm engine)
Maintenance standard
80 mmHg
(Measured at the intake duct of the turbocharger)

Examples of turbocharger failure

Turbocharger failure is evidenced by decreased engine output, excessive fuel consumption or black exhaust smoke. Abnormal boost pressure indicates the necessity of inspection and possible overhaul of the turbocharger and intake and exhaust systems.

Factors which may cause low boost pressure

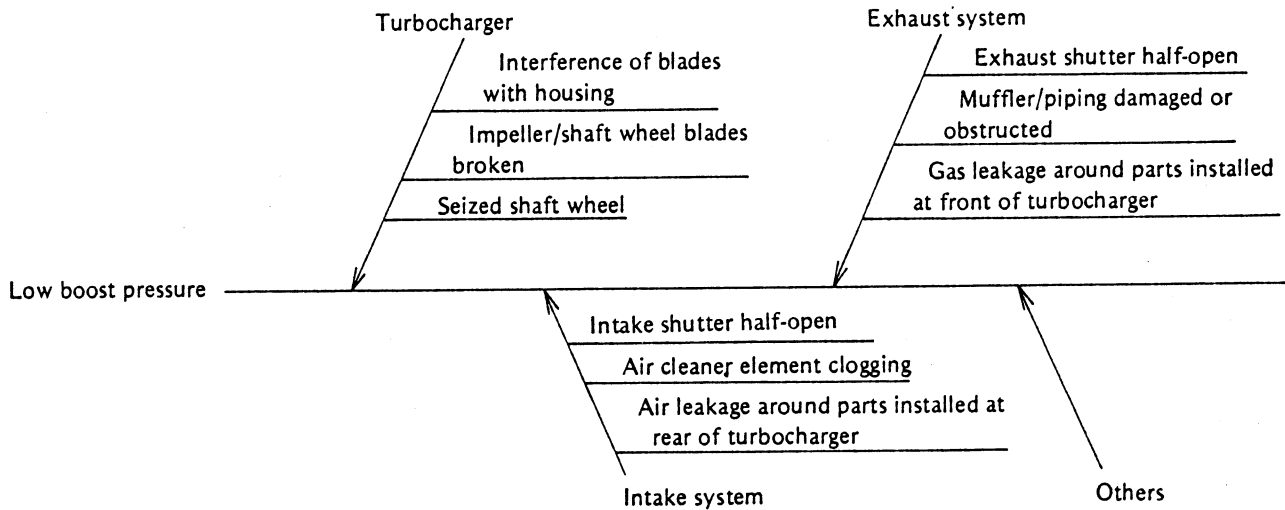

NO-LOAD ACCELERATION AND DECELERATION TEST

The condition of an engine can be judged by checking its acceleration and deceleration speeds. This test is performed under a no-load condition.

No-load acceleration and deceleration test (Warm engine)

Acceleration

Maintenance standard
Max. 1.5 sec.

Deceleration

Maintenance standard
Max. 3.0 sec.

Trouble symptom

Trouble symptoms relating to improper acceleration or deceleration are as follows: low engine output, deteriorated fuel consumption and difficulty in shifting of transmission.

Slow deceleration is generally caused by poor governor performance, such as improper adjustment of damper spring, or idle spring, or too high idling adjustment by control knob.

Causes of slow acceleration or deceleration

Slow acceleration is caused by low compression pressure, increase in blow-by gas pressure, and failure in fuel system.

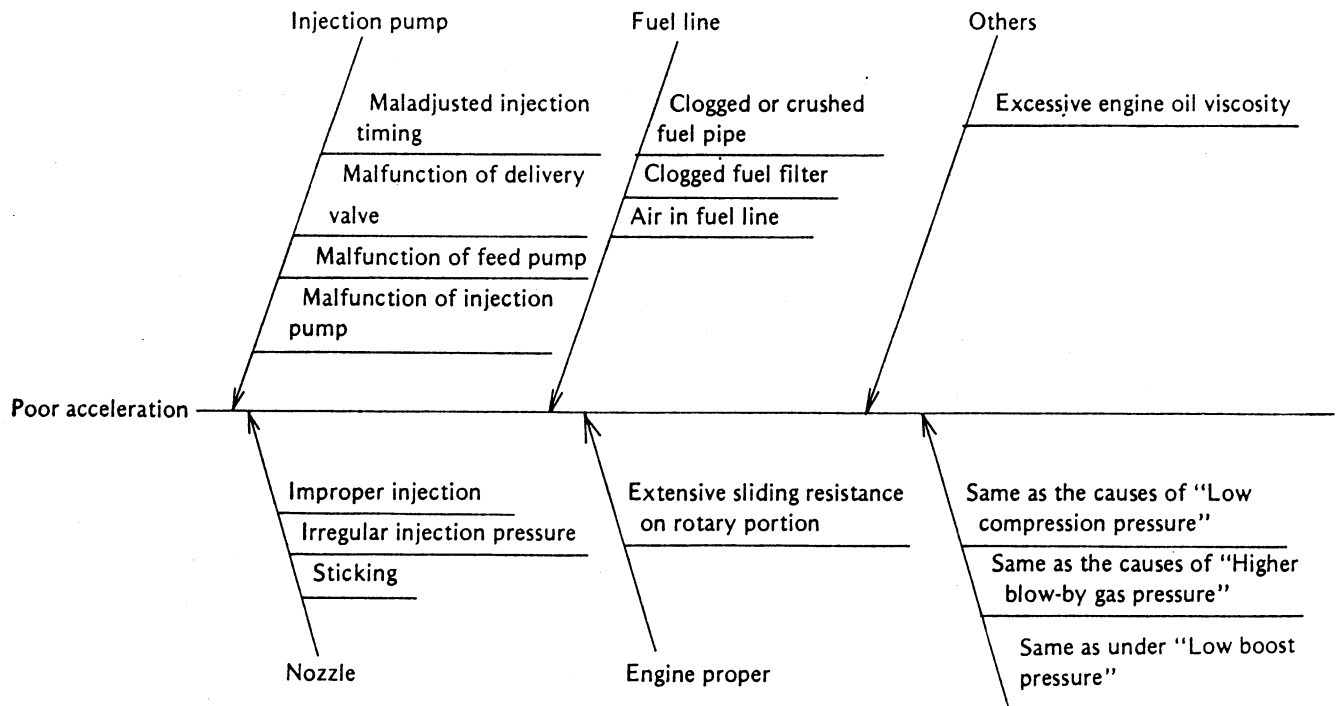



Suggest:

For more complete manuals. Please go to the home page.

<https://www.ebooklibonline.com>

If the above button click is invalid. Please download this document first, and then click the above link to download the complete manual.

Thank you so much for reading

MEASURING WATER TEMPERATURE DIFFERENCE BETWEEN RADIATOR INLET AND OUTLET

This test is performed to check whether the radiator is functioning normally. It is desirable to examine temperature during the running state using a thermister.

Water temperature difference between radiator inlet and outlet
Maintenance standard
 Approx. 5 to 7°C

Trouble symptom

Excessive temperature differences can cause engine overheating.

Possible causes

- 1) Extreme water temperature differences are caused by water scale or foreign matter obstructing normal water flow in the radiator.
- 2) Slight water temperature differences are caused by foreign matter such as mud and insects accumulated on the radiator core fin, obstructing smooth flow of air through the fins.

LITMUS TEST OF COOLING WATER

Check the pH value of the cooling water using the litmus paper. (Use blue litmus paper.)

Trouble symptom

If the acidity of cooling water is excessively high, engine overheating or reduction in the quantity of cooling water may result.

Causes of higher acidity

If the burnt gases leak through the cylinder head gasket into cooling water, the sulfurous acid gas in the burnt gases dissolves into water, thus increasing the acidity of the water.

PRESSURE TEST OF WATER TANK CAP AND RADIATOR CAP

Faulty water tank cap and radiator cap can cause the amount of cooling water to be reduced or the engine to overheat. Therefore, the water tank cap and radiator cap should be checked periodically.

Water tank cap type
Maintenance standard
 0.6 to 0.8 kg/cm²

Radiator cap type
Maintenance standard
 0.8 to 1.0 kg/cm²

ENGINE OIL SPOT TEST

The engine oil spot test is performed to evaluate the condition of the engine oil, thereby judging whether or not the engine oil requires changing. A spot test kit is available from the petroleum manufacturer, and the spot test should be performed by referring to the Instructions given in the kit.

MEASURING SPECIFIC GRAVITY OF FUEL

Poor quality fuel not only causes reduction in engine output, but also causes failure in the nozzle and plunger and clogging in the fuel filter element. If any of these failures is observed, it is also necessary to measure the viscosity of fuel in order to judge whether fuel quality is acceptable. Generally speaking, reduction of 10% in the specific gravity can cause 5 to 7% increase in the fuel consumption, and alike decrease in engine output.

Relation between temperature and specific gravity

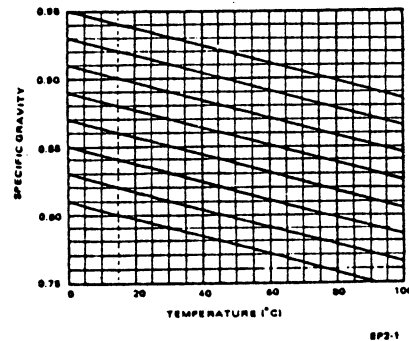

CAUSE OF TROUBLE AND ITS CORRECTION

PRECAUTIONS ON TROUBLE-SHOOTING AND REPAIRING

- 1) Prior to disassembly, confirm the nature of the problem. Determine the following points and the conditions before and after the occurrence of trouble by asking the user.
 1. Did the trouble occurred suddenly?
 2. Was there anything unusual before occurrence of the trouble?
 3. Under what condition did the trouble occur?
 4. Was there any repair work done recently?
 5. Is there any other unusual phenomenon?
- 2) Confirm the nature of the problem in the shop (by the service mechanic himself).
Reconfirm the nature of the problem complained of by user, and perform tests using various testing equipment in the shop. Then, make a guess as to the cause of the trouble.

3) Thorough investigation of the trouble prior to disassembly can prevent unnecessary procedures, enabling quick and efficient repair work. Note that disassembly without preliminary investigation often makes reproduction of the problem difficult, thus making trouble-shooting impossible.

- 4) Always start with a simple operation.

After making a guess as to the cause of the trouble, perform investigation or repair work starting with the simplest operation.

- 5) Always consider the cause of the trouble.

The same problem will occur repeatedly if the symptoms only are corrected without removing the real cause of the trouble. Be sure to seek out the origin of the trouble and remove it completely.

Example: An engine was brought to the shop because of oil leakage from the crankshaft front oil seal,

and the problem was repaired by simply replacing the oil seal.

If the cause of this problem is faulty oil seal, there is no problem. However, oil leakage is often a secondary problem resulting from another primary cause, and the primary cause must be removed without fail.

In the case of the above example, the cause of the trouble may be one of the following:

- The blow-by gas pressure is excessively high, and engine oil sprouts out due to the high pressure.
- Mis-aligned crankshaft due to wear on main bearing shell.

DIAGNOSIS GUIDE

The diagnosis guide is a table which can be used for seeking out the cause of trouble without disassembling the engine on the basis of the symptoms of the problem and the result of checks performed in the shop.

HOW TO USE THE GUIDE

- 1) Open the page of the guide corresponding to the trouble symptom complained of by the user.
- 2) Check all of the points listed in the page.
- 3) If there is any applicable item in the checking points, the cause of the trouble may be assumed in the following manner.
 - Each item in the "Symptoms and checking points" section corresponds to one or more items in the "Cause of trouble"

section through the dot mark "●". If there are more than one applicable "Cause of trouble" items, the item having the largest number of dot marks should be regarded as the central cause of the trouble.

- The "cause" items having no dot mark can be regarded as not being the cause of the trouble.

Note

If more than one cause is assumed, repair operation should begin with the simplest operation.

<https://www.ebooklibonline.com>

Hello dear friend!

Thank you very much for reading.

Enter the link into your browser.

The full manual is available for immediate download.

<https://www.ebooklibonline.com>