



F4DFE613A\*A, F4DFE613B\*A, F4DFE613C\*A, F4DFE613D\*A, F4DFE613G\*A,  
F4DFE613H\*A, F4DFE613J\*A, F4DFE613K\*A, F4DFE613L\*A, F4HFE413H\*A,  
F4HFE613I\*A, F4HFE613G\*A, F4HFE613H\*A, F4HFE613J\*A, F4HFE613K\*A,  
F4HFE613P\*A, F4HFE613R\*A, F4HFE613X\*A, F4HFE613Y\*A

## SERVICE MANUAL

Engine

**NEF Tier 4a**

# Contents

---

## INTRODUCTION

## HYDRAULIC, PNEUMATIC, ELECTRICAL, ELECTRONIC SYSTEMS A

ELECTRICAL POWER SYSTEM ..... A.30.A

## ENGINE AND PTO IN ..... B

ENGINE ..... B.10.A

FUEL AND INJECTION SYSTEM..... B.20.A

AIR INTAKE SYSTEM..... B.30.A

EXHAUST SYSTEM..... B.40.A

ENGINE COOLANT SYSTEM ..... B.50.A

EXHAUST SYSTEM Emissions control ..... B.40.B

LUBRICATION SYSTEM ..... B.60.A

STARTING SYSTEM ..... B.80.A



## INTRODUCTION

**<https://www.ebooklibonline.com>**

Hello dear friend!

Thank you very much for reading.

Enter the link into your browser.

The full manual is available for immediate download.

**<https://www.ebooklibonline.com>**

# Contents

---

## INTRODUCTION

Foreword - Ecology and the environment .....	3
Safety rules .....	4
Torque .....	5
Basic instructions - Important notice regarding equipment servicing .....	8
Basic instructions - How To Use and Navigate Through This Manual .....	9
Basic instructions - Shop and Assembly .....	14
Torque - Minimum tightening torques for normal assembly .....	16

---

## Foreword - Ecology and the environment

Soil, air, and water are vital factors of agriculture and life in general. When legislation does not yet rule the treatment of some of the substances which are required by advanced technology, sound judgement should govern the use and disposal of products of a chemical and petrochemical nature.

**NOTICE:** *The following are recommendations which may be of assistance:*

- Become acquainted with and ensure that you understand the relative legislation applicable to your country.
- Where no legislation exists, obtain information from suppliers of oils, filters, batteries, fuels, antifreeze, cleaning agents, etc., with regard to their effect on man and nature and how to safely store, use and dispose of these substances.
- Agricultural consultants will, in many cases, be able to help you as well.

### HELPFUL HINTS

- Avoid filling tanks using cans or inappropriate pressurized fuel delivery systems which may cause considerable spillage.
- In general, avoid skin contact with all fuels, oils, acids, solvents, etc. Most of them contain substances which may be harmful to your health.
- Modern oils contain additives. Do not burn contaminated fuels and or waste oils in ordinary heating systems.
- Avoid spillage when draining off used engine coolant mixtures, engine, gearbox and hydraulic oils, brake fluids, etc. Do not mix drained brake fluids or fuels with lubricants. Store them safely until they can be disposed of in a proper way to comply with local legislation and available resources.
- Modern coolant mixtures, i.e. antifreeze and other additives, should be replaced every two years. They should not be allowed to get into the soil but should be collected and disposed of properly.
- Do not open the air-conditioning system yourself. It contains gases which should not be released into the atmosphere. Your CNH dealer or air conditioning specialist has a special extractor for this purpose and will have to recharge the system properly.
- Repair any leaks or defects in the engine cooling or hydraulic system immediately.
- Do not increase the pressure in a pressurized circuit as this may lead to a component failure.
- Protect hoses during welding as penetrating weld splatter may burn a hole or weaken them, allowing the loss of oils, coolant, etc.

## Safety rules

### Personal safety





This is the safety alert symbol. It is used to alert you to potential personal injury hazards. Obey all safety messages that follow this symbol to avoid possible death or injury.

Throughout this manual and on machine decals, you will find the signal words DANGER, WARNING, and CAUTION followed by special instructions. These precautions are intended for the personal safety of you and those working with you.

Read and understand all the safety messages in this manual before you operate or service the machine.

 DANGER indicates a hazardous situation which, if not avoided, will result in death or serious injury. The color associated with DANGER is RED.

 WARNING indicates a hazardous situation which, if not avoided, could result in death or serious injury. The color associated with WARNING is ORANGE.

 CAUTION, used with the safety alert symbol, indicates a hazardous situation which, if not avoided, could result in minor or moderate injury. The color associated with CAUTION is YELLOW.

### **FAILURE TO FOLLOW DANGER, WARNING, AND CAUTION MESSAGES COULD RESULT IN DEATH OR SERIOUS INJURY.**

### Machine safety

**NOTICE:** Notice indicates a situation which, if not avoided, could result in machine or property damage. The color associated with Notice is BLUE.

Throughout this manual you will find the signal word Notice followed by special instructions to prevent machine or property damage. The word Notice is used to address practices not related to personal safety.

### Information

**NOTE:** Note indicates additional information which clarifies steps, procedures, or other information in this manual.

Throughout this manual you will find the word Note followed by additional information about a step, procedure, or other information in the manual. The word Note is not intended to address personal safety or property damage.

## Torque

Component	Size	Specification
<b>Cylinder Head and Components</b>		
Plug	1/4"	10 - 14 Nm (7.4 - 10.3 lb ft)
	1/2"	20 - 28 Nm (14.8 - 20.7 lb ft)
	3/4"	31 - 41 Nm (22.9 - 30.2 lb ft)
Grid Heater	M6 Nut	6 - 10 Nm (4.4 - 7.4 lb ft)
Intake Manifold	M8 Screw	20 - 28 Nm (14.8 - 20.7 lb ft)
<b>Engine Lifting Bracket</b>		
Rear	M12	65 - 89 Nm (47.9 - 65.6 lb ft)
Front	M8	20 - 28 Nm (14.8 - 20.7 lb ft)
Cylinder Head	<b>M12x1.75x130 mm</b>	
First Phase		30 - 40 Nm (22.1 - 29.5 lb ft)
Second Phase		85 - 95 °
Third Phase		85 - 95 °
Cylinder Head	<b>M12x1.75x150 mm</b>	
First Phase		50 - 60 Nm (36.9 - 44.3 lb ft)
Second Phase		85 - 95 °
Third Phase		85 - 95 °
Rocker Bracket		31 - 41 Nm (22.9 - 30.2 lb ft)
Rocker Arm Jam Nuts		20 - 28 Nm (14.8 - 20.7 lb ft)
Exhaust Manifold		48 - 58 Nm (35.4 - 42.8 lb ft)
Valve Cover	M8 Nut	20 - 28 Nm (14.8 - 20.7 lb ft)
<b>Turbocharger</b>		
6 Cylinder	M8 Screw	6 - 8 Nm (4.4 - 5.9 lb ft)
	M8 Nut	37 - 49 Nm (27.3 - 36.1 lb ft)
4 Cylinder	M8 Screw	6 - 8 Nm (4.4 - 5.9 lb ft)
	M8 Nut	20 - 28 Nm (14.8 - 20.7 lb ft)
<b>Front Case</b>		
Front Cover	M8 Screw	20 - 28 Nm (14.8 - 20.7 lb ft)
<b>Rear Case</b>		
Gear Case	M12 Screw	65 - 89 Nm (47.9 - 65.6 lb ft)
	M10 Screw	42 - 52 Nm (31.0 - 38.4 lb ft)
	M8 Screw	20 - 28 Nm (14.8 - 20.7 lb ft)
Flywheel Housing	M10	75 - 95 Nm (55.3 - 70.1 lb ft)
	M12	44 - 54 Nm (32.5 - 39.8 lb ft)
<b>Cylinder Block and Crankshaft Components</b>		
Camshaft Retaining Plate	M8 Screw	20 - 28 Nm (14.8 - 20.7 lb ft)
Camshaft Gear	M8 Screw	32 - 40 Nm (23.6 - 29.5 lb ft)
Crankcase Plate	M10 Screw	38 - 48 Nm (28.0 - 35.4 lb ft)
<b>Vibration Damper and Adapter</b>		
First Phase		45 - 55 Nm (33.2 - 40.6 lb ft)
Second Phase		90 °
Drive Pulley	M10	61 - 75 Nm (45.0 - 55.3 lb ft)
<b>Engine Flywheel</b>		
First Phase		26 - 34 Nm (19.2 - 25.1 lb ft)
Second Phase		55 - 65 °
<b>Main Caps</b>		
First Phase	M12	44 - 56 Nm (32.5 - 41.3 lb ft)
Second Phase		74 - 86 Nm (54.6 - 63.4 lb ft)
Third Phase		85 - 95 °
<b>Connecting Rod Caps</b>		
First Phase		55 - 65 Nm (40.6 - 47.9 lb ft)
Second Phase		55 - 65 °

INTRODUCTION

Component	Size	Specification
<b>Lubrication System and Components</b>		
Oil Pump		
First Phase	M8	7 - 9 Nm (5.2 - 6.6 lb ft)
Second Phase	M8	20 - 28 Nm (14.8 - 20.7 lb ft)
Oil Pressure Relief Valve	M22	72 - 88 Nm (53.1 - 64.9 lb ft)
Oil Cooler and Oil Filter Base	M8 Screw	20 - 28 Nm (14.8 - 20.7 lb ft)
Oil Filter		Contact + ¾ Turn
Connection on Filter Base for Turbo Oil Supply	1 ⅛"	20 - 28 Nm (14.8 - 20.7 lb ft)
Turbo Lubrication Pipe	M12 Nut	8 - 12 Nm (5.9 - 8.9 lb ft)
Turbo Lubrication Pipe Adapter	M12	30 - 40 Nm (22.1 - 29.5 lb ft)
Oil Pan		20 - 28 Nm (14.8 - 20.7 lb ft)
Piston Spray Nozzles	M8	12 - 18 Nm (8.9 - 13.3 lb ft)
<b>Electrical Components</b>		
Camshaft Sensor	M6 Studs	6 - 10 Nm (4.4 - 7.4 lb ft)
	M6 Nut	8 - 12 Nm (5.9 - 8.9 lb ft)
	M6 Screw	6 - 10 Nm (4.4 - 7.4 lb ft)
Wiring Bulkhead	M6 Screw	8 - 12 Nm (5.9 - 8.9 lb ft)
Support Bracket for Injector Wiring	M8 Screw	20 - 28 Nm (14.8 - 20.7 lb ft)
Injector Wiring		1.25 - 1.75 Nm (0.92 - 1.29 lb ft)
ECU Cooling Plate	M6 Screw	8 - 12 Nm (5.9 - 8.9 lb ft)
	M8 Screw	20 - 28 Nm (14.8 - 20.7 lb ft)
Fuel Outlet	M12	10 - 14 Nm (7.4 - 10.3 lb ft)
Fuel Inlet	M12	10 - 14 Nm (7.4 - 10.3 lb ft)
Crankshaft Speed Sensor	M6 Screw	6 - 10 Nm (4.4 - 7.4 lb ft)
Coolant Temperature Sensor	M14 Screw	17 - 23 Nm (12.5 - 17.0 lb ft)
Oil Pressure / Temperature Sensor	M5 Screw	5 - 7 Nm (3.7 - 5.2 lb ft)
Fuel Pressure Sensor		30 - 40 Nm (22.1 - 29.5 lb ft)
Fuel Temperature Sensor	M14	17 - 23 Nm (12.5 - 17.0 lb ft)
Air Pressure / Temperature Sensor		5 - 7 Nm (3.7 - 5.2 lb ft)
Engine Oil Level Sensor	M12	10 - 14 Nm (7.4 - 10.3 lb ft)
Alternator Support Bracket	M10 Screw	37 - 49 Nm (27.3 - 36.1 lb ft)
Alternator Tension Bracket	M10 Screw	37 - 49 Nm (27.3 - 36.1 lb ft)
Starter		37 - 49 Nm (27.3 - 36.1 lb ft)
<b>Fuel System and Components</b>		
Feed Pump	M8 Studs	10 - 14 Nm (7.4 - 10.3 lb ft)
High Pressure Pump Gear	M18 Nut	100 - 110 Nm (73.8 - 81.1 lb ft)
Fuel Pump	M8 Nut	20 - 28 Nm (14.8 - 20.7 lb ft)
Injector		
First Phase	M6 Screw	8.15 - 8.85 Nm (6.0 - 6.5 lb ft)
Second Phase	M6 Screw	70 - 80 °
Injector Feed Connector		45 - 55 Nm (33.2 - 40.6 lb ft)
Common Rail	M8 Screw	20 - 28 Nm (14.8 - 20.7 lb ft)
High Pressure Fuel Line	M14 Fitting	18 - 22 Nm (13.3 - 16.2 lb ft)
High Pressure Pipe Connector	M8 Screw	20 - 28 Nm (14.8 - 20.7 lb ft)
Fuel Filter Bracket	M12 Screw	71 - 85 Nm (52.4 - 62.7 lb ft)
Fuel Filter Holder	M8 Screw	20 - 28 Nm (14.8 - 20.7 lb ft)
Fuel Filter		Contact + ¾ Turn
<b>Cooling System and Components</b>		

INTRODUCTION

<b>Component</b>	<b>Size</b>	<b>Specification</b>
Engine Coolant Inlet	M10 Screw	<b>37 - 49 Nm (27.3 - 36.1 lb ft)</b>
Fitting on Coolant Inlet	<b>90 °</b> Elbow	<b>20 - 28 Nm (14.8 - 20.7 lb ft)</b>
Compressor Cooling Pipe		<b>20 - 24 Nm (14.8 - 17.7 lb ft)</b>
Engine Coolant Drain Collector	M6 Screw	<b>8 - 12 Nm (5.9 - 8.9 lb ft)</b>
Water Pump	M8 Screw	<b>20 - 28 Nm (14.8 - 20.7 lb ft)</b>
Belt Tensioner	M10	<b>37 - 49 Nm (27.3 - 36.1 lb ft)</b>
Idler Pulleys	M10	<b>37 - 49 Nm (27.3 - 36.1 lb ft)</b>

---

## **Basic instructions - Important notice regarding equipment servicing**

All repair and maintenance work listed in this manual must be carried out only by qualified dealership personnel, strictly complying with the instructions given, and using, whenever possible, the special tools.

Anyone who performs repair and maintenance operations without complying with the procedures provided herein shall be responsible for any subsequent damages.

The manufacturer and all the organizations of its distribution chain, including - without limitation - national, regional, or local dealers, reject any responsibility for damages caused by parts and/or components not approved by the manufacturer, including those used for the servicing or repair of the product manufactured or marketed by the manufacturer. In any case, no warranty is given or attributed on the product manufactured or marketed by the manufacturer in case of damages caused by parts and/or components not approved by the manufacturer.

The information in this manual is up-to-date at the date of the publication. It is the policy of the manufacturer for continuous improvement. Some information could not be updated due to modifications of a technical or commercial type, or changes to the laws and regulations of different countries.

In case of questions, refer to your CNH Sales and Service Networks.

---

## Basic instructions - How To Use and Navigate Through This Manual

### Technical Information

This manual has been produced by a new technical information system. This new system is designed to deliver technical information electronically through Web delivery, DVD and in paper manuals. A coding system called SAP has been developed to link the technical information to other Product Support functions, e.g., Warranty.

Technical information is written to support the maintenance and service of the functions or systems on a customer's machine. When a customer has a concern on his machine it is usually because a function or system on his machine is not working at all, is not working efficiently, or is not responding correctly to his commands. When you refer to the technical information in this manual to resolve that customer's concern, you will find all the information classified using the SAP coding, according to the functions or systems on that machine. Once you have located the technical information for that function or system then you will find all the mechanical, electrical or hydraulic devices, components, assemblies and sub assemblies for that function or system. You will also find all the types of information that have been written for that function or system, the technical data (specifications), the functional data (how it works), the diagnostic data (fault codes and troubleshooting) and the service data (remove, install adjust, etc.).

By integrating SAP coding into technical information, you will be able to search and retrieve just the right piece of technical information you need to resolve that customer's concern on his machine. This is made possible by attaching 3 categories to each piece of technical information during the authoring process.

The first category is the Location, the second category is the Information Type and the third category is the Product:

- LOCATION - is the component or function on the machine, that the piece of technical information is going to describe e.g. Fuel tank.
- INFORMATION TYPE - is the piece of technical information that has been written for a particular component or function on the machine e.g. Capacity would be a type of Technical Data that would describe the amount of fuel held by the Fuel tank.
- PRODUCT - is the model for which the piece of technical information is written.

Every piece of technical information will have those 3 categories attached to it. You will be able to use any combination of those categories to find the right piece of technical information you need to resolve that customer's concern on his machine.

That information could be:

- the description of how to remove the cylinder head
- a table of specifications for a hydraulic pump
- a fault code
- a troubleshooting table
- a special tool

## How to Use this Manual

This manual is divided into Sections. Each Section is then divided into Chapters. Contents pages are included at the beginning of the manual, then inside every Section and inside every Chapter. An alphabetical Index is included at the end of a Chapter. Page number references are included for every piece of technical information listed in the Chapter Contents or Chapter Index.

Each Chapter is divided into four Information types:

- Technical Data (specifications) for all the mechanical, electrical or hydraulic devices, components and assemblies.
- Functional Data (how it works) for all the mechanical, electrical or hydraulic devices, components and assemblies.
- Diagnostic Data (fault codes, electrical and hydraulic troubleshooting) for all the mechanical, electrical or hydraulic devices, components and assemblies.
- Service Data (remove disassembly, assemble, install) for all the mechanical, electrical or hydraulic devices, components and assemblies.

## Sections

Sections are grouped according to the main functions or a systems on the machine. Each Section is identified by a letter A, B, C etc. The amount of Sections included in the manual will depend on the type and function of the machine that the manual is written for. Each Section has a Contents page listed in alphabetic/numeric order. This table illustrates which Sections could be included in a manual for a particular product.

PRODUCT	SECTION										
	A - Hydraulic – Pneumatic – Electrical – Electronic Systems										
	B - Engine and PTO In										
	C - Transmission, Drive and PTO Out										
	D - Axles, Brakes and Steering										
	E - Frame and Cab										
	F - Frame Positioning										
	G - Tool Positioning										
	H - Hitch and Working Tool										
	J - Excavating and Landscaping										
	K - Crop Processing										
L - Field Processing											
Tractors	X	X	X	X	X	X		X	X		
Vehicles with working arms: backhoes, excavators, skid steers, .....	X	X	X	X	X	X	X	X	X		
Combines, forage harvesters, balers, ....	X	X	X	X	X	X	X	X	X	X	
Seeding, planting, floating, spraying equipment, ....	X	X	X	X	X	X		X			X
Mounted equipment and tools, .....					X	X	X		X		

**Section Contents**

<b>SECTION</b>	<b>LETTER</b>	<b>DESCRIPTION</b>
HYDRAULIC – PNEUMATIC – ELECTRICAL – ELECTRONIC SYSTEMS	A	This Section covers the main systems that interact with most of the functions of the product. It includes the central parts of the hydraulic, electrical, electronic, pneumatic, lighting and grease lubrication systems. The components that are dedicated to a specific function are listed in the Chapter where all the technical information for that function is included.
ENGINE AND PTO IN	B	This Section covers all the functions related to the production of power to move the machine and to drive various devices. In the case of a pulled-type machine, this Section covers the power take-off function where power is provided from the towing machine.
TRANSMISSION, DRIVE AND PTO OUT	C	This Section covers all the functions related to the transmission of power from the engine to the axles and to internal or external devices. This Section also covers the power take-off function where power is provided to the pull-type machine and additional Process Drive functions.
AXLES, BRAKES AND STEERING	D	This Section covers all the functions related to moving the machine, including tracks, wheels, steering and braking. It covers all the axles; both driven axles and non-driven axles, including any axle suspension.
FRAME AND CAB	E	This Section covers all the main functions and systems related to the structure and the body of the machine, including the frame, the shields, the operators cab and the platform. The functions related to the positioning of the machine frame are included in Section F, Frame Positioning.
FRAME POSITIONING	F	This Section covers all the main functions and systems related to positioning of the machine frame or to positioning the attachment on the supporting machine frame.
TOOL POSITIONING	G	This Section covers all the functions related to the final and/or automatic positioning of the tool once the tool is positioned using the Working Arm or the machine frame.
HITCH AND WORKING TOOL	H	This Section covers all the functions related to the articulated or single arms mounted on the front or rear of the machine. A working arm can have various tools and quick couplers mounted on it. The tools and quick couplers are included in Section J, Excavating and Landscaping.
EXCAVATING AND LANDSCAPING	J	This Section covers all the functions related to the specific tools that mount on the front, rear or beside the machine. The tools described here can be mounted with the positioning systems (lifting, side shift, swing) listed in Section G Tool Positioning. This Section covers all the quick coupling systems, located between the tool and the positioning system. The tools used for field preparation, soil preparation and treatment, planting and seeding are included.
CROP PROCESSING	K	This Section covers all the functions related to crop processing. Examples of crop processing include threshing, baling, windrowing, cutting and conditioning.
FIELD PROCESSING	L	This Section covers all the field processing functions of the machine. Examples of field process include seeding, fertilizer application, seedbed preparation and chemical application.

This manual contains these Sections:

**Contents**

INTRODUCTION	
HYDRAULIC – PNEUMATIC – ELECTRICAL – ELECTRONIC SYSTEMS	A
ENGINE AND PTO IN	B
FRAME POSITIONING	F
CROP PROCESSING	K

**Chapters**

Each Chapter is identified by a letter and number combination e.g. Engine B.10.A The first letter is identical to the Section letter i.e. Chapter B.10 is inside Section B, Engine and PTO In.

**CONTENTS**

The Chapter Contents lists all the technical data (specifications), functional data (how it works), service data (remove, install adjust, etc..) and diagnostic data (fault codes and troubleshooting) that have been written in that Chapter for that function or system on the machine.

**Contents**

ENGINE AND PTO IN  
ENGINE \_ 10.A

TECHNICAL DATA  
ENGINE - General specification (B.10.A)

FUNCTIONAL DATA  
ENGINE - Dynamic description (B.10.A)

SERVICE  
ENGINE - Remove (B.10.A)

DIAGNOSTIC  
ENGINE - Troubleshooting (B.10.A)

**INDEX**

The Chapter Index lists in alphabetical order all the types of information (called Information Units) that have been written in that Chapter for that function or system on the machine.

**Index**

ENGINE AND PTO IN - B  
ENGINE

ENGINE - Dynamic description (B.10.A)

ENGINE - General specification (B.10.A)

ENGINE - Remove (B.10.A)

ENGINE - Troubleshooting (B.10.A)

## Information Units and Information Search

Each chapter is composed of information units. Each information unit has the SAP code shown in parentheses which indicates the function and the type of information written in that information unit. Each information unit has a page reference within that Chapter. The information units provide a quick and easy way to find just the right piece of technical information you are looking for.

Example information unit	Stack valve - Sectional View (A.10.A.18)		
Information Unit SAP code	A	10.A	18
SAP code classification	Hydraulic – Pneumatic – Electrical – Electronic Systems	Primary hydraulic power	Stack valve

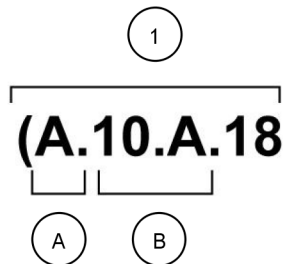

CRIL03J033E01A 1

Navigate to the correct information unit you are searching for by identifying the function and information type from the SAP code.

- **(1)** Function and **(2)** Information type.
- **(A)** corresponds to the sections of the repair manual.  
**(B)** corresponds to the chapters of the repair manual.  
**(C)** corresponds to the type of information listed in the chapter contents, Technical Data, Functional Data, Diagnostic or Service.  
**(A)** and **(B)** are also shown in the page numbering on the page footer.  
THE REST OF THE CODING IS NOT LISTED IN ALPHANUMERIC ORDER IN THIS MANUAL.
- You will find a table of contents at the beginning and end of each section and chapter.  
You will find an alphabetical index at the end of each chapter.
- By referring to **(A)**, **(B)** and **(C)** of the coding, you can follow the contents or index (page numbers) and quickly find the information you are looking for.

## Page Header and Footer

The page header will contain the following references:

- Section and Chapter description

The page footer will contain the following references:

- Publication number for that Manual, Section or Chapter.
- Version reference for that publication.
- Publication date
- Section, chapter and page reference e.g. A.10.A / 9

---

## Basic instructions - Shop and Assembly

### SHIMMING

For each adjustment operation, select adjusting shims and measure individually using a micrometer, then add up the recorded values. Do not rely on measuring the entire shimming set, which may be incorrect, or the rated value indicated on each shim.

### ROTATING SHAFT SEALS

For correct rotating shaft seal installation, proceed as follows:

- before assembly, allow the seal to soak in the oil it will be sealing for at least thirty minutes.
- thoroughly clean the shaft and check that the working surface on the shaft is not damaged.
- position the sealing lip facing the fluid; with hydrodynamic lips, take into consideration the shaft rotation direction and position the grooves so that they will deviate the fluid towards the inner side of the seal.
- coat the sealing lip with a thin layer of lubricant (use oil rather than grease) and fill the gap between the sealing lip and the dust lip on double lip seals with grease.
- insert the seal in its seat and press down using a flat punch or seal installation tool. Do not tap the seal with a hammer or mallet.
- whilst inserting the seal, check that it is perpendicular to the seat; once settled, make sure that it makes contact with the thrust element, if required.
- to prevent damaging the seal lip on the shaft, position a protective guard during installation operations.

### O-RING SEALS

Lubricate the O-RING seals before inserting them in the seats, this will prevent them from overturning and twisting, which would jeopardise sealing efficiency.

### SEALING COMPOUNDS

Apply one of the following sealing compounds on the mating surfaces when specified: SILMATE® RTV1473, or LOCTITE® RTV 598 or LOCTITE® INSTANT GASKET 587 BLUE. Before applying the sealing compound, prepare the surfaces as directed on product container or as follows:

- remove any incrustations using a metal brush.
- thoroughly de-grease the surfaces using a locally approved cleaning agent such as safety solvent or brake parts cleaner.

### SPARE PARTS

Only use "CNH Original Parts" or " CNH Parts".

Only genuine spare parts guarantee the same quality, duration and safety as original parts, as they are the same parts that are assembled during standard production. Only "CNH Original Parts" or " CNH Parts" can offer this guarantee.

When ordering spare parts, always provide the following information:

- machine model (commercial name) and serial number
- part number of the ordered part, which can be found in the "Microfiches" or the "Service Parts Catalogue", used for order processing

---

## PROTECTING THE ELECTRONIC/ ELECTRICAL SYSTEMS DURING CHARGING OR WELDING

To avoid damage to the electronic/electrical systems, always observe the following:

1. Never make or break any of the charging circuit connections, including the battery connections, when the engine is running.
2. Never short any of the charging components to ground.
3. Always disconnect the ground cable from the battery before arc welding on the combine or on any header attached to the combine.
  - position the welder ground clamp as close to the welding area as possible
  - if welding in close proximity to a computer module, then the module should be removed from the combine
  - never allow welding cables to lay on, near or across any electrical wiring or electronic component while welding is in progress
4. Always disconnect the negative cable from the battery when charging the battery in the combine with a battery charger.

**NOTICE:** *If welding must be performed on the unit, either the combine or the header (if it is attached), the battery ground cable must be disconnected from the combine battery. The electronic monitoring system and charging system will be damaged if this is not done.*

Remove the battery ground cable. Reconnect the cable when welding is completed.



**Battery acid causes severe burns. Batteries contain sulfuric acid. Avoid contact with skin, eyes or clothing. Antidote - EXTERNAL: flush with water. INTERNAL: drink large quantities of water or milk. Follow with milk of magnesia, beaten egg or vegetables oil. Call physician immediately. EYES: flush with water for 15 minutes and get prompt medical attention.**

84-110

## TOOLS

The tools that CNH suggests and illustrate in this manual have been:

- specifically researched and designed for use with CNH machines
- essential for reliable repair operations
- accurately built and rigorously tested so as to offer efficient and long-lasting operation

By using these tools, repair personnel will benefit from:

- operating in optimal technical conditions
- obtaining the best results
- saving time and effort
- working in safe conditions

**NOTE:** *The terms "front", "rear", "right-hand" and "left-hand" (when referred to different parts) are determined from the rear, facing in the direction of travel of the machine during operation.*

## Torque - Minimum tightening torques for normal assembly

### METRIC NON-FLANGED HARDWARE

NOM. SIZE	CLASS 8.8 BOLT and CLASS 8 NUT		CLASS 10.9 BOLT and CLASS 10 NUT		LOCKNUT CL.8 W/CL8.8 BOLT	LOCKNUT CL.10 W/CL10.9 BOLT
	UNPLATED	PLATED W/ZnCr	UNPLATED	PLATED W/ZnCr		
M4	2.2 N·m (19 lb in)	2.9 N·m (26 lb in)	3.2 N·m (28 lb in)	4.2 N·m (37 lb in)	2 N·m (18 lb in)	2.9 N·m (26 lb in)
M5	4.5 N·m (40 lb in)	5.9 N·m (52 lb in)	6.4 N·m (57 lb in)	8.5 N·m (75 lb in)	4 N·m (36 lb in)	5.8 N·m (51 lb in)
M6	7.5 N·m (66 lb in)	10 N·m (89 lb in)	11 N·m (96 lb in)	15 N·m (128 lb in)	6.8 N·m (60 lb in)	10 N·m (89 lb in)
M8	18 N·m (163 lb in)	25 N·m (217 lb in)	26 N·m (234 lb in)	35 N·m (311 lb in)	17 N·m (151 lb in)	24 N·m (212 lb in)
M10	37 N·m (27 lb ft)	49 N·m (36 lb ft)	52 N·m (38 lb ft)	70 N·m (51 lb ft)	33 N·m (25 lb ft)	48 N·m (35 lb ft)
M12	64 N·m (47 lb ft)	85 N·m (63 lb ft)	91 N·m (67 lb ft)	121 N·m (90 lb ft)	58 N·m (43 lb ft)	83 N·m (61 lb ft)
M16	158 N·m (116 lb ft)	210 N·m (155 lb ft)	225 N·m (166 lb ft)	301 N·m (222 lb ft)	143 N·m (106 lb ft)	205 N·m (151 lb ft)
M20	319 N·m (235 lb ft)	425 N·m (313 lb ft)	440 N·m (325 lb ft)	587 N·m (433 lb ft)	290 N·m (214 lb ft)	400 N·m (295 lb ft)
M24	551 N·m (410 lb ft)	735 N·m (500 lb ft)	762 N·m (560 lb ft)	1016 N·m (750 lb ft)	501 N·m (370 lb ft)	693 N·m (510 lb ft)

**NOTE:** M4 through M8 hardware torque specifications are shown in pound-inches. M10 through M24 hardware torque specifications are shown in pound-feet.

**METRIC FLANGED HARDWARE**

NOM. SIZE	CLASS 8.8 BOLT and CLASS 8 NUT		CLASS 10.9 BOLT and CLASS 10 NUT		LOCKNUT CL.8 W/CL8.8 BOLT	LOCKNUT CL.10 W/CL10.9 BOLT
	UNPLATED	PLATED W/ZnCr	UNPLATED	PLATED W/ZnCr		
M4	2.4 N·m (21 lb in)	3.2 N·m (28 lb in)	3.5 N·m (31 lb in)	4.6 N·m (41 lb in)	2.2 N·m (19 lb in)	3.1 N·m (27 lb in)
M5	4.9 N·m (43 lb in)	6.5 N·m (58 lb in)	7.0 N·m (62 lb in)	9.4 N·m (83 lb in)	4.4 N·m (39 lb in)	6.4 N·m (57 lb in)
M6	8.3 N·m (73 lb in)	11 N·m (96 lb in)	12 N·m (105 lb in)	16 N·m (141 lb in)	7.5 N·m (66 lb in)	11 N·m (96 lb in)
M8	20 N·m (179 lb in)	27 N·m (240 lb in)	29 N·m (257 lb in)	39 N·m (343 lb in)	18 N·m (163 lb in)	27 N·m (240 lb in)
M10	40 N·m (30 lb ft)	54 N·m (40 lb ft)	57 N·m (42 lb ft)	77 N·m (56 lb ft)	37 N·m (27 lb ft)	53 N·m (39 lb ft)
M12	70 N·m (52 lb ft)	93 N·m (69 lb ft)	100 N·m (74 lb ft)	134 N·m (98 lb ft)	63 N·m (47 lb ft)	91 N·m (67 lb ft)
M16	174 N·m (128 lb ft)	231 N·m (171 lb ft)	248 N·m (183 lb ft)	331 N·m (244 lb ft)	158 N·m (116 lb ft)	226 N·m (167 lb ft)
M20	350 N·m (259 lb ft)	467 N·m (345 lb ft)	484 N·m (357 lb ft)	645 N·m (476 lb ft)	318 N·m (235 lb ft)	440 N·m (325 lb ft)
M24	607 N·m (447 lb ft)	809 N·m (597 lb ft)	838 N·m (618 lb ft)	1118 N·m (824 lb ft)	552 N·m (407 lb ft)	

**IDENTIFICATION**

**Metric Hex head and carriage bolts, classes 5.6 and up**

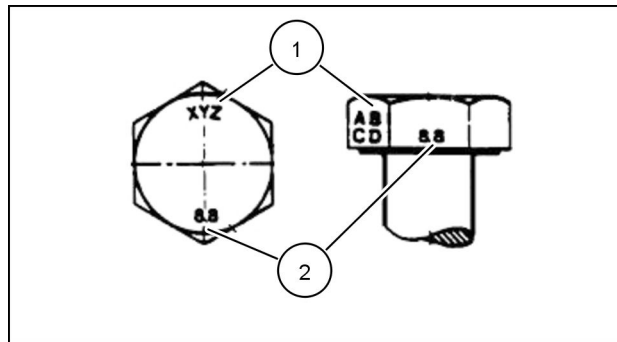

20083680 1

1. Manufacturer's Identification
2. Property Class

**Metric Hex nuts and locknuts, classes 05 and up**

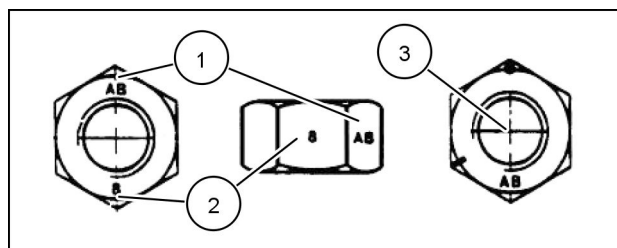

20083681 2

1. Manufacturer's Identification
2. Property Class
3. Clock Marking of Property Class and Manufacturer's Identification (Optional), i.e. marks **60 °** apart indicate Class 10 properties, and marks **120 °** apart indicate Class 8.

**INCH NON-FLANGED HARDWARE**

NOMINAL SIZE	SAE GRADE 5 BOLT and NUT		SAE GRADE 8 BOLT and NUT		LOCKNUT GrB W/ Gr5 BOLT	LOCKNUT GrC W/ Gr8 BOLT
	UN-PLATED or PLATED SILVER	PLATED W/ZnCr GOLD	UN-PLATED or PLATED SILVER	PLATED W/ZnCr GOLD		
1/4	8 N·m (71 lb in)	11 N·m (97 lb in)	12 N·m (106 lb in)	16 N·m (142 lb in)	8.5 N·m (75 lb in)	12.2 N·m (109 lb in)
5/16	17 N·m (150 lb in)	23 N·m (204 lb in)	24 N·m (212 lb in)	32 N·m (283 lb in)	17.5 N·m (155 lb in)	25 N·m (220 lb in)
3/8	30 N·m (22 lb ft)	40 N·m (30 lb ft)	43 N·m (31 lb ft)	57 N·m (42 lb ft)	31 N·m (23 lb ft)	44 N·m (33 lb ft)
7/16	48 N·m (36 lb ft)	65 N·m (48 lb ft)	68 N·m (50 lb ft)	91 N·m (67 lb ft)	50 N·m (37 lb ft)	71 N·m (53 lb ft)
1/2	74 N·m (54 lb ft)	98 N·m (73 lb ft)	104 N·m (77 lb ft)	139 N·m (103 lb ft)	76 N·m (56 lb ft)	108 N·m (80 lb ft)
9/16	107 N·m (79 lb ft)	142 N·m (105 lb ft)	150 N·m (111 lb ft)	201 N·m (148 lb ft)	111 N·m (82 lb ft)	156 N·m (115 lb ft)
5/8	147 N·m (108 lb ft)	196 N·m (145 lb ft)	208 N·m (153 lb ft)	277 N·m (204 lb ft)	153 N·m (113 lb ft)	215 N·m (159 lb ft)
3/4	261 N·m (193 lb ft)	348 N·m (257 lb ft)	369 N·m (272 lb ft)	491 N·m (362 lb ft)	271 N·m (200 lb ft)	383 N·m (282 lb ft)
7/8	420 N·m (310 lb ft)	561 N·m (413 lb ft)	594 N·m (438 lb ft)	791 N·m (584 lb ft)	437 N·m (323 lb ft)	617 N·m (455 lb ft)
1	630 N·m (465 lb ft)	841 N·m (620 lb ft)	890 N·m (656 lb ft)	1187 N·m (875 lb ft)	654 N·m (483 lb ft)	924 N·m (681 lb ft)

**NOTE:** For Imperial Units, 1/4 in and 5/16 in hardware torque specifications are shown in pound-inches. 3/8 in through 1 in hardware torque specifications are shown in pound-feet.

**INCH FLANGED HARDWARE**

NOM- INAL SIZE	SAE GRADE 5 BOLT and NUT		SAE GRADE 8 BOLT and NUT		LOCKNUT GrF W/ Gr5 BOLT	LOCKNUT GrG W/ Gr8 BOLT
	UNPLATED or PLATED SILVER	PLATED W/ZnCr GOLD	UNPLATED or PLATED SILVER	PLATED W/ZnCr GOLD		
1/4	9 N·m (80 lb in)	12 N·m (106 lb in)	13 N·m (115 lb in)	17 N·m (150 lb in)	8 N·m (71 lb in)	12 N·m (106 lb in)
5/16	19 N·m (168 lb in)	25 N·m (221 lb in)	26 N·m (230 lb in)	35 N·m (310 lb in)	17 N·m (150 lb in)	24 N·m (212 lb in)
3/8	33 N·m (25 lb ft)	44 N·m (33 lb ft)	47 N·m (35 lb ft)	63 N·m (46 lb ft)	30 N·m (22 lb ft)	43 N·m (32 lb ft)
7/16	53 N·m (39 lb ft)	71 N·m (52 lb ft)	75 N·m (55 lb ft)	100 N·m (74 lb ft)	48 N·m (35 lb ft)	68 N·m (50 lb ft)
1/2	81 N·m (60 lb ft)	108 N·m (80 lb ft)	115 N·m (85 lb ft)	153 N·m (113 lb ft)	74 N·m (55 lb ft)	104 N·m (77 lb ft)
9/16	117 N·m (86 lb ft)	156 N·m (115 lb ft)	165 N·m (122 lb ft)	221 N·m (163 lb ft)	106 N·m (78 lb ft)	157 N·m (116 lb ft)
5/8	162 N·m (119 lb ft)	216 N·m (159 lb ft)	228 N·m (168 lb ft)	304 N·m (225 lb ft)	147 N·m (108 lb ft)	207 N·m (153 lb ft)
3/4	287 N·m (212 lb ft)	383 N·m (282 lb ft)	405 N·m (299 lb ft)	541 N·m (399 lb ft)	261 N·m (193 lb ft)	369 N·m (272 lb ft)
7/8	462 N·m (341 lb ft)	617 N·m (455 lb ft)	653 N·m (482 lb ft)	871 N·m (642 lb ft)	421 N·m (311 lb ft)	594 N·m (438 lb ft)
1	693 N·m (512 lb ft)	925 N·m (682 lb ft)	979 N·m (722 lb ft)	1305 N·m (963 lb ft)	631 N·m (465 lb ft)	890 N·m (656 lb ft)

**IDENTIFICATION**

**Inch Bolts and free-spinning nuts**

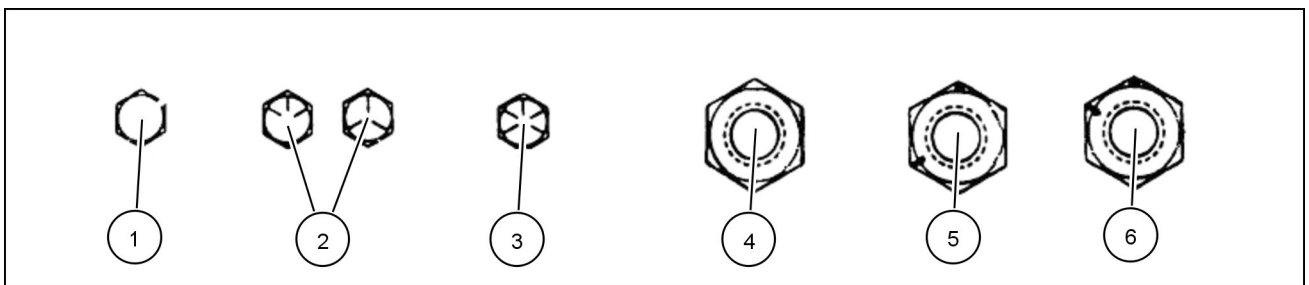

20083682 3

**Grade Marking Examples**

SAE Grade Identification			
1	Grade 2 - No Marks	4	Grade 2 Nut - No Marks
2	Grade 5 - Three Marks	5	Grade 5 Nut - Marks 120 ° Apart
3	Grade 8 - Five Marks	6	Grade 8 Nut - Marks 60 ° Apart

**Inch Lock Nuts, All Metal (Three optional methods)**

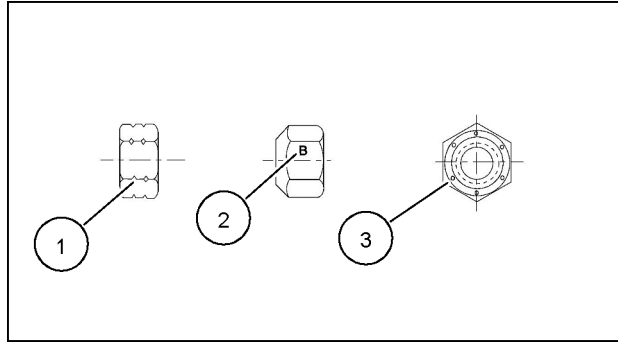

20090268 4

**Grade Identification**

Grade	Corner Marking Method (1)	Flats Marking Method (2)	Clock Marking Method (3)
Grade A	No Notches	No Mark	No Marks
Grade B	One Circumferential Notch	Letter B	Three Marks
Grade C	Two Circumferential Notches	Letter C	Six Marks



## SERVICE MANUAL

HYDRAULIC, PNEUMATIC, ELECTRICAL, ELECTRONIC SYSTEMS

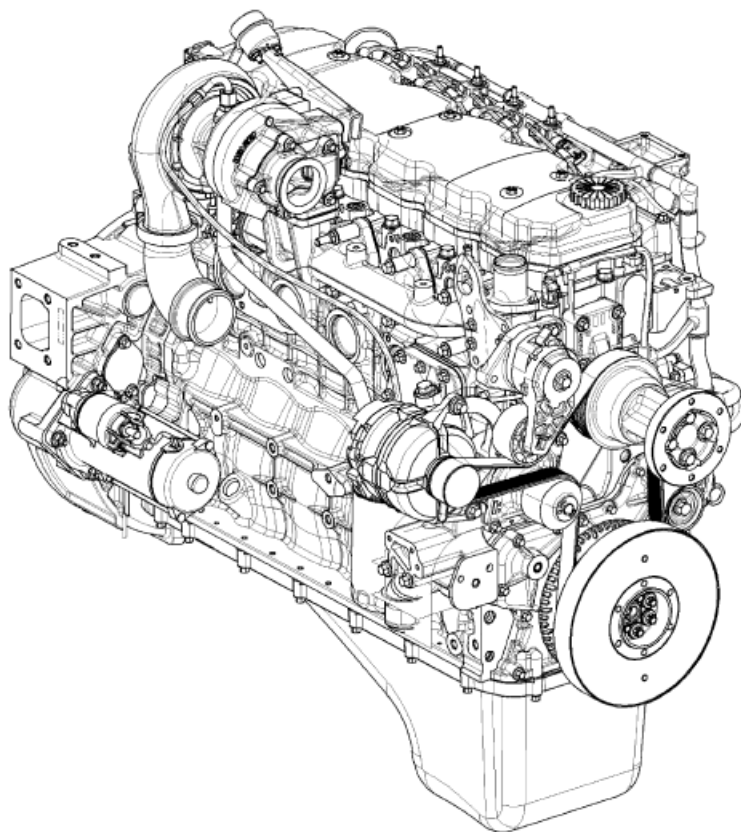

**F4DFE613A\*A , F4DFE613B\*A , F4DFE613C\*A , F4DFE613D\*A , F4DFE613G\*A  
 , F4DFE613H\*A , F4DFE613J\*A , F4DFE613K\*A , F4DFE613L\*A , F4HFE413H\*A  
 , F4HFE6131\*A , F4HFE613G\*A , F4HFE613H\*A , F4HFE613J\*A , F4HFE613K\*A  
 , F4HFE613P\*A , F4HFE613R\*A , F4HFE613X\*A , F4HFE613Y\*A**

# Contents

---

## HYDRAULIC, PNEUMATIC, ELECTRICAL, ELECTRONIC SYSTEMS - A

ELECTRICAL POWER SYSTEM .....	A.30.A
F4DFE613A*A , F4DFE613B*A , F4DFE613C*A , F4DFE613D*A , F4DFE613G*A , F4DFE613H*A , F4DFE613J*A , F4DFE613K*A , F4DFE613L*A , F4HFE413H*A , F4HFE6131*A , F4HFE613G*A , F4HFE613H*A , F4HFE613J*A , F4HFE613K*A , F4HFE613P*A , F4HFE613R*A , F4HFE613X*A , F4HFE613Y*A	



## **HYDRAULIC, PNEUMATIC, ELECTRICAL, ELECTRONIC SYSTEMS - A**

### **ELECTRICAL POWER SYSTEM - 30.A**

**F4DFE613A\*A , F4DFE613B\*A , F4DFE613C\*A , F4DFE613D\*A , F4DFE613G\*A  
, F4DFE613H\*A , F4DFE613J\*A , F4DFE613K\*A , F4DFE613L\*A , F4HFE413H\*A  
, F4HFE6131\*A , F4HFE613G\*A , F4HFE613H\*A , F4HFE613J\*A , F4HFE613K\*A  
, F4HFE613P\*A , F4HFE613R\*A , F4HFE613X\*A , F4HFE613Y\*A**

# Contents

---

## HYDRAULIC, PNEUMATIC, ELECTRICAL, ELECTRONIC SYSTEMS - A

### ELECTRICAL POWER SYSTEM - 30.A

#### SERVICE

Alternator	
Remove .....	3
Install .....	4

## Alternator - Remove

### Prior operation:

#### Fan and drive Belt - Remove (B.50.A)

1. Remove the cables from the back of the alternator.
2. Remove the retaining bolts (2) securing the alternator (1) to the support.
3. Remove the alternator (1).

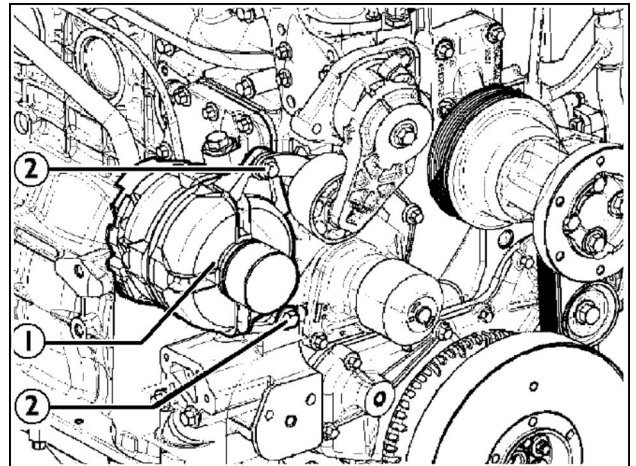

ALTERNATOR 1

### Next operation:

#### Alternator - Install (A.30.A)



**Suggest:**

**For more complete manuals. Please go to the home page.**

**<https://www.ebooklibonline.com>**

**If the above button click is invalid. Please download this document first, and then click the above link to download the complete manual.**

**Thank you so much for reading**

## Alternator - Install

### Prior operation:

#### Alternator - Remove (A.30.A)

1. Install the alternator (1) and tighten the bolts (2) to the specified torque.
2. Connect the positive and negative cables onto the back of the alternator.

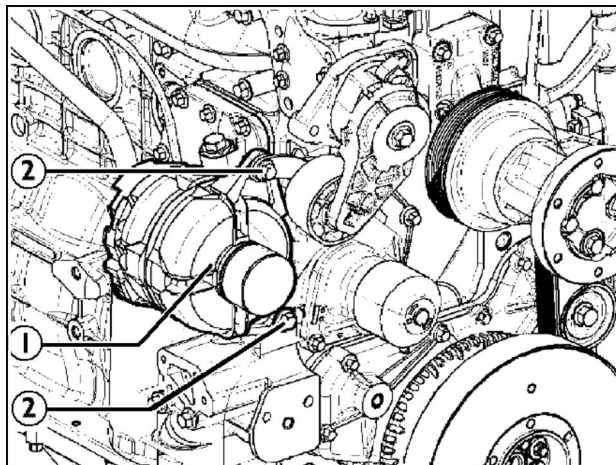

ALTERNATOR 1

### Next operation:

#### Fan and drive Belt - Install (B.50.A)

# Index

---

## HYDRAULIC, PNEUMATIC, ELECTRICAL, ELECTRONIC SYSTEMS - A

### ELECTRICAL POWER SYSTEM - 30.A

Alternator - Install .....	4
Alternator - Remove .....	3

**<https://www.ebooklibonline.com>**

Hello dear friend!

Thank you very much for reading.

Enter the link into your browser.

The full manual is available for immediate download.

**<https://www.ebooklibonline.com>**