

KOBELCO

SERVICE MANUAL

mitsubishi DIESEL ENGINE

4D3, DR

For Industrial Use

Applicable Engine Models: 4D31, 4D31-T, 4D30
4DR5, 6DR5

MITSUBISHI DIESEL ENGINE

SHOP MANUAL

MODEL

4D3, DR

(FOR INDUSTRIAL USE)



CONTENTS

ORGANIZATION	
GENERAL	00
ENGINE	11
LUBRICATION	12
FUEL AND ENGINE CONTROL	13
COOLING	14
INTAKE AND EXHAUST	15
ENGINE ELECTRICAL	16
CLUTCH	21
TRANSMISSION	22
PARKING BRAKE	36

<https://www.ebooklibonline.com>

Hello dear friend!

Thank you very much for reading.

Enter the link into your browser.

The full manual is available for immediate download.

<https://www.ebooklibonline.com>

ORGANIZATION

1. Group Classification

This manual is organized into several groups classified according to the engine basic elements.

No.	Group name	Description
00	General	External view, major specifications, engine outputs classified by application, engine numbers, nameplate, caution plate, general bolts and nuts tightening torque table
11	Engine	Engine proper (cylinder head, valve mechanism, camshaft, piston, crankshaft, timing gear, flywheel), air compressor, flywheel PTO, specifications, service standards, special tools, troubleshooting
12	Lubrication	Lubrication system (oil pump, oil filter, oil cooler), specifications, service standards, special tools, troubleshooting
13	Fuel and engine control	Fuel system (injection pump, injection nozzle, fuel filter, water separator), specifications, service standards, special tools, troubleshooting
14	Cooling	Cooling system (water pump, thermostat, radiator, cooling system cleaning procedures, fan), specifications, service standards, special tools, troubleshooting
15	Intake and exhaust	Air cleaner, turbocharger, manifolds, specifications, service standards, troubleshooting
16	Engine electrical	Starter, alternator, vacuum pump, preheating system, relays, automatic stop device, specifications, service standards, special tools, troubleshooting
21	Clutch	Clutch proper, clutch control (power cylinder, master cylinder, clutch lever), specifications, service standards, special tools, troubleshooting
22	Transmission	Transmission proper, bearing case, specifications, service standards, special tools, troubleshooting
36	Parking brake	Parking brake (brake drum, brake shoe), specifications, service standards, special tools, troubleshooting

NOTE: Each group starts with page 1.

2. General Precautions for Servicing

Before starting the service procedures, check the vehicle for total time driven, use conditions, and user's complaints and requests to know exactly the engine conditions. Record information where necessary.

To ensure you are doing correct and efficient service jobs, observe the following precautions.

- (1) Before performing the service procedures given in this manual, know the trouble spots and isolate the possible cause to determine whether the removal or disassembly procedure is required.



A0012A

- (2) Select a flat surface for the service job.
- (3) When servicing the electrical system, be sure to disconnect the negative cable from the battery.
- (4) Carefully check parts for oil leaks before cleaning. After cleaning, it may become difficult to spot defective areas.
- (5) Ready and make the most of the special tools required for servicing. Use the right tools (specified special tools) in the right place to prevent damages to parts and personal injury.
- (6) Make alignment marks and keep disassembled parts neatly arranged to ensure that they are reassembled into the right positions.
 - Special care must be taken for assemblies involving a number of parts, similar parts, or parts identical at right- and left-hand sides to ensure correct reassembly.
 - For alignment and punching markings, select a position that would not mar the appearance and function.
 - Clearly distinguish parts to be replaced from those reused.
- (7) The oil seals, packings, O-rings, and other rubber parts, gaskets, and split pins must be replaced with a new one whenever they are removed. For replacement, use Mitsubishi Genuine Parts.

**MITSUBISHI MOTORS
GENUINE PARTS**

A0006A

- (8) Apply the specified grease to U-packings, oil seals, dust seals, and bearings before installation.

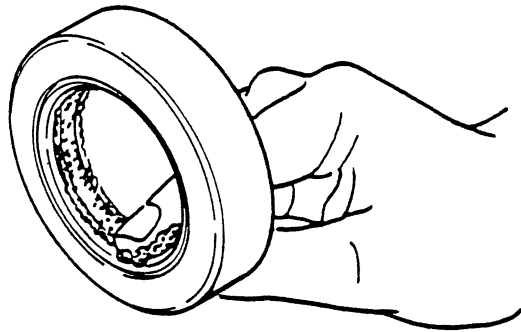

A0007A

- (9) When work requires an assistant or two, always make sure of the safety each other. Never play with switches and levers.
- (10) Make sure that your shoes are free from grease and oil especially when working on a heavy item.
- (11) When checking or changing lubricants, wipe off grease and oil from parts immediately with a waste.
- (12) Special care must be taken in handling sensors and relays which are susceptible to shocks and heat.
- (13) Use care so that hands and fingers are not injured by sharp edges or corners of the parts.
- (14) Wear safety goggles whenever handling a grinder or welding machine. Wear gloves as required to ensure utmost safety.

3. Terms and Units

The following terms and units are used throughout the entire texts of this manual.

(1) Front and Rear

The terms "front" is the fan side and "rear" the flywheel side of the engine.

(2) Right and Left

The terms "right" and "left" shall be used to indicate the side as viewed from the flywheel side of the engine.

(3) Service Standard Terms

● Nominal value

Shows the nominal dimensions, dimension of an individual part, standard clearance between parts in an assembly, or the standard performance of an assembly.

- Limit

Shows the value of a part at which the part is no longer serviceable from the performance as well as strength viewpoints, requiring replacement or repair.

(4) Tightening Torque

Over- or undertightening of bolts and nuts has critical effects on performance and functions. Tightening torque is therefore specified for some tightening points.

All tightening torque specifications may be considered as "dry" unless "wet" is specified.

Where no tightening torque is specified, use a torque value specified in the general bolts and nuts tightening torque table.

(5) Units

For length, weight, area, and volume, the SI unit (International System of units) is used with the metric notation jointly shown in parentheses.

Temperature is shown in centigrade (°C).

4. Table of Conversion Rate for Foot-pound Units into SI Units

Unit	Sign of SI unit	Sign of foot-pound unit	Conversion rate
Mass quantity of matter	kg g	lb oz	1 kg = 2.2046 lb 1 g = 0.035274 oz
Dimension	m mm	ft. in.	1 m = 3.2808 ft. 1 mm = 0.03937 in.
Capacity	lit. cc	gal. oz	1 lit. = 0.2642 gal. (U.S.) 1 lit. = 0.220 gal. (Imp.) 1 cc = 0.033814 oz (U.S.) 1 cc = 0.035195 oz (Imp.)
Force	N (Newton)	lbf	1 N = 0.2248 lbf
Pressure	kPa (kilopascal)	lbf/in. ²	1 kPa = 0.145 lbf/in. ² 1 kPa = 0.2953 in.Hg
Stress	N/cm ²	lbf/in. ²	1 N/cm ² = 1.45 lbf/in. ²
Moment of force	N m	ft. lbf	1 N m = 0.7375 ft. lbf
Output	kW (kilowatt)	HP	1 kW = 1.34 HP
Temperature	°C	°F	t °C = (1.8t °C + 32) °F

5. Reading the Illustration

(Ex. 1: Disassembly and Inspection)

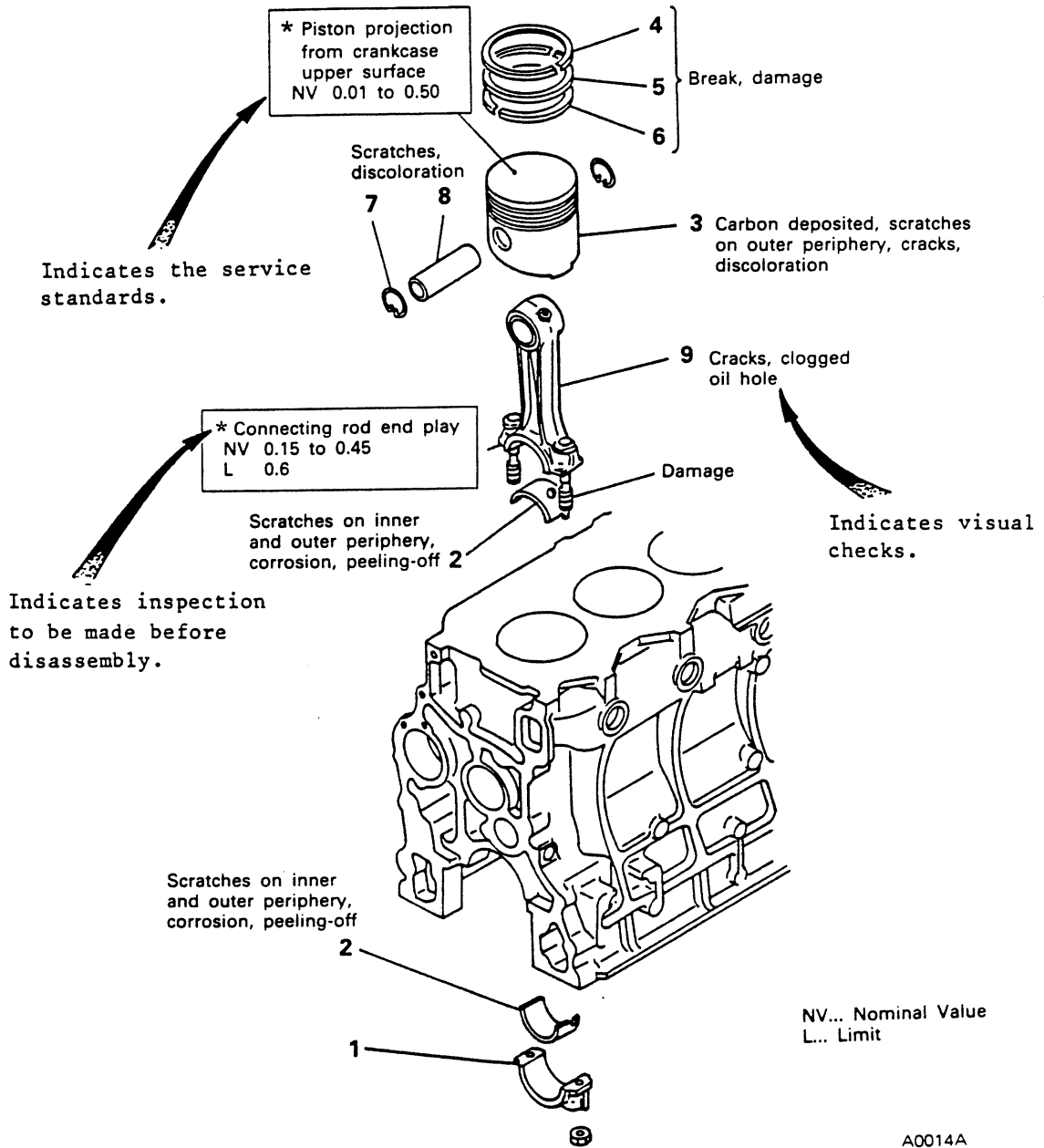

A0014A

Numbers assigned indicate a typical disassembly sequence.

- | | | |
|--------------------------|--------------------------|------------------|
| 1 Connecting rod cap | (4) 1st compression ring | 7 Snap ring |
| 2 Connecting rod bearing | (5) 2nd compression ring | 8 Piston pin |
| 3 Piston | (6) Oil ring | 9 Connecting rod |

Indicates that the disassembly procedure is explained in the text.

(Ex. 2: Reassembly)

Gives instruction for jobs.
to be done at reassembly.

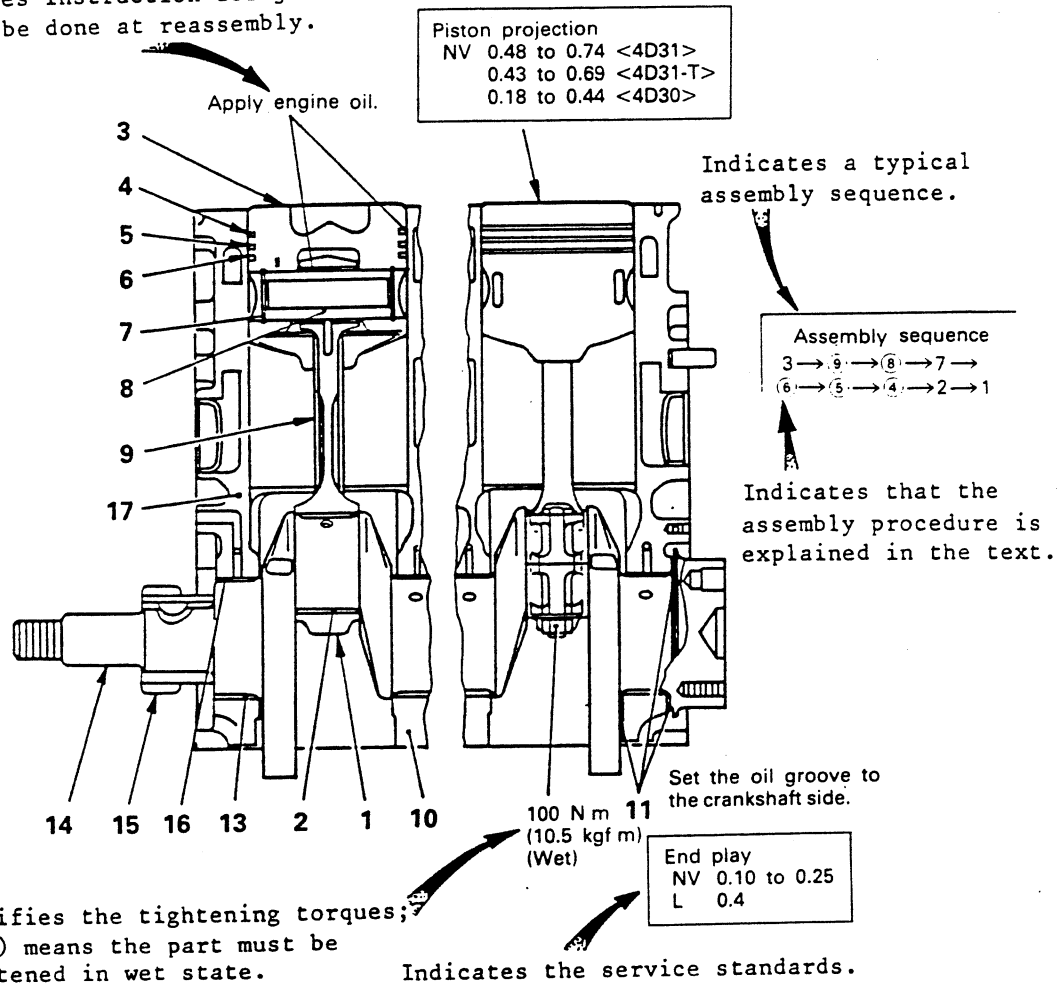

NV... Nominal Value
 L... Limit

A0013A

- (1) Illustrations (exploded views and assembly drawings) show a typical service procedures if it is identical among various types of available systems and units.

GROUP 00 GENERAL

CONTENTS

00

1. EXTERNAL VIEW 00-1

2. MAJOR SPECIFICATIONS 00-5

 2-1 Major Specifications 00-5

 2-2 Engine Outputs Classified by
 Application 00-6

3. ENGINE NUMBERS, NAMEPLATE, CAUTION
 PLATE 00-7

4. GENERAL BOLTS AND NUTS TIGHTENING
 TORQUE TABLE 00-9

1. EXTERNAL VIEW

4D31 Model

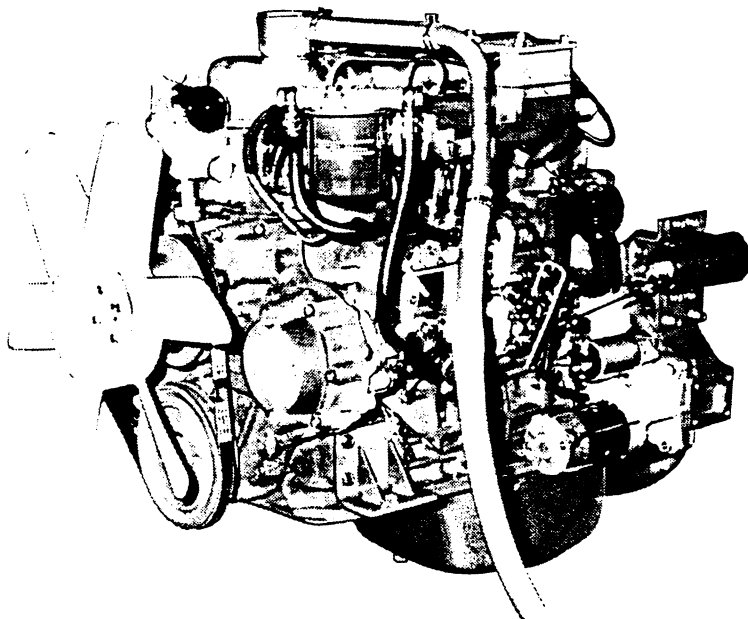

PE1021

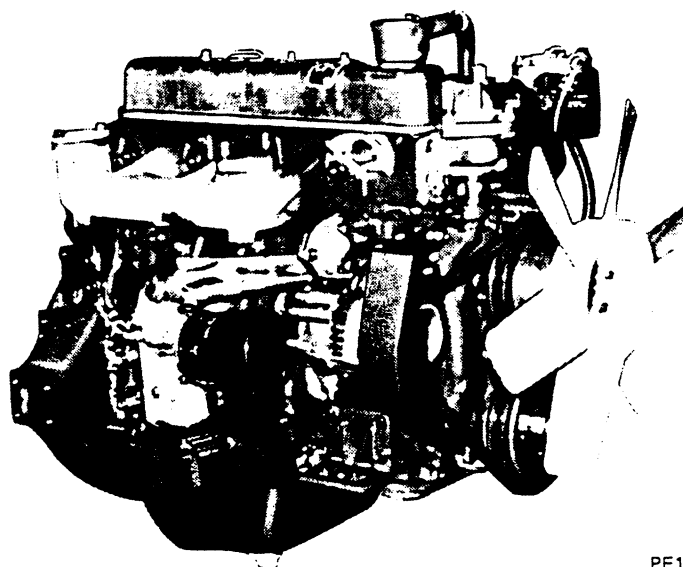

PE1022

4D31-T Model

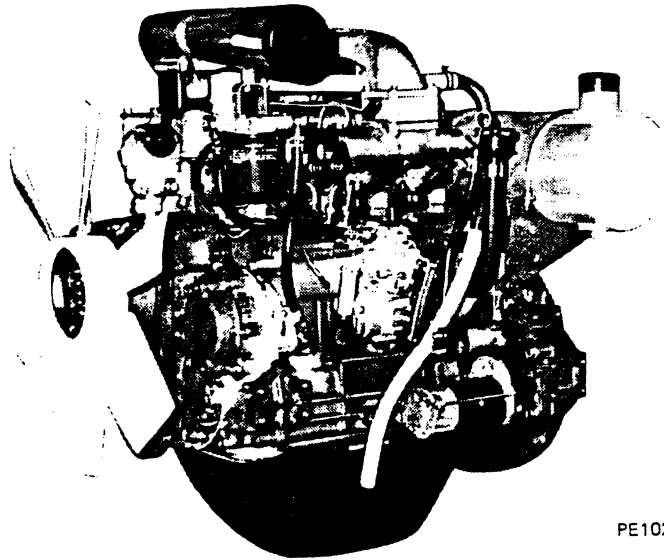

PE1023

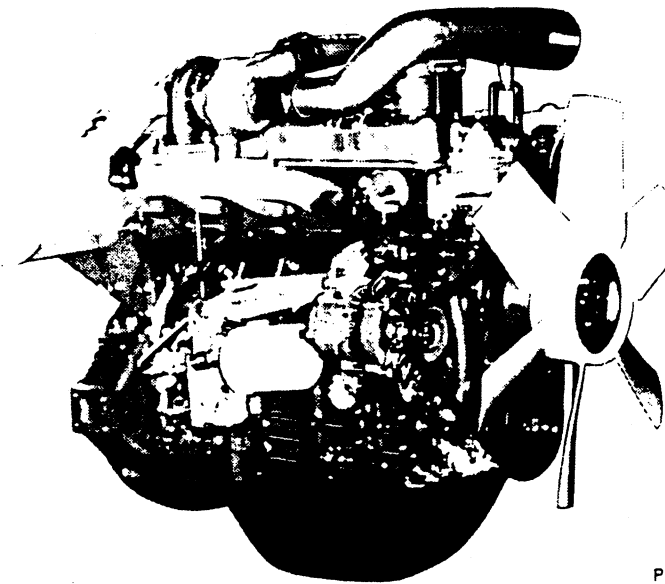

PE1024

4DR5 Model 1

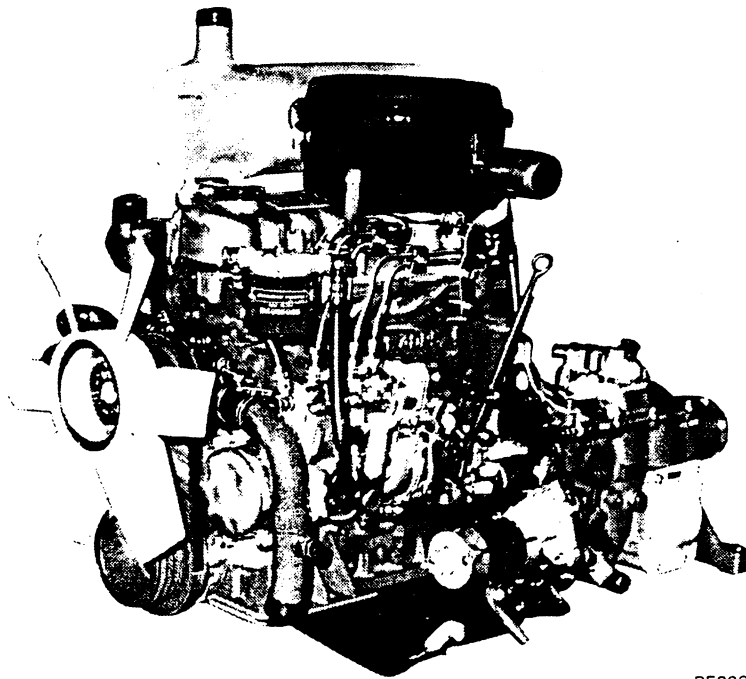

PE2061

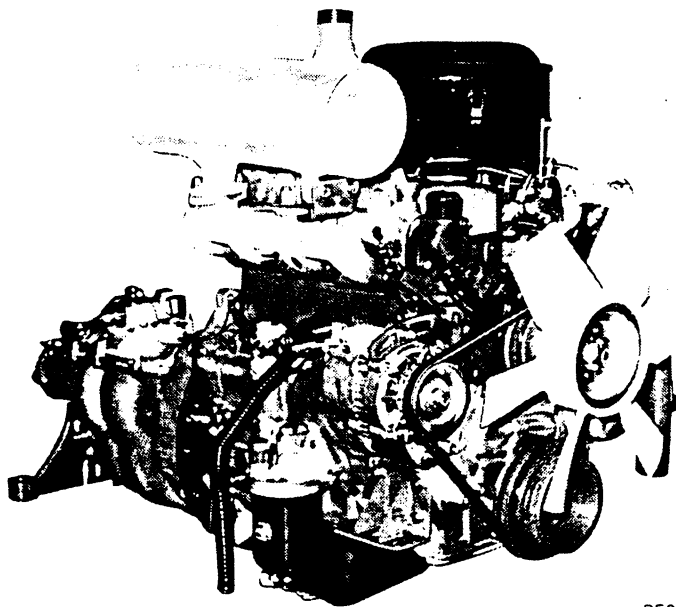

PE2062

6DR5 Model

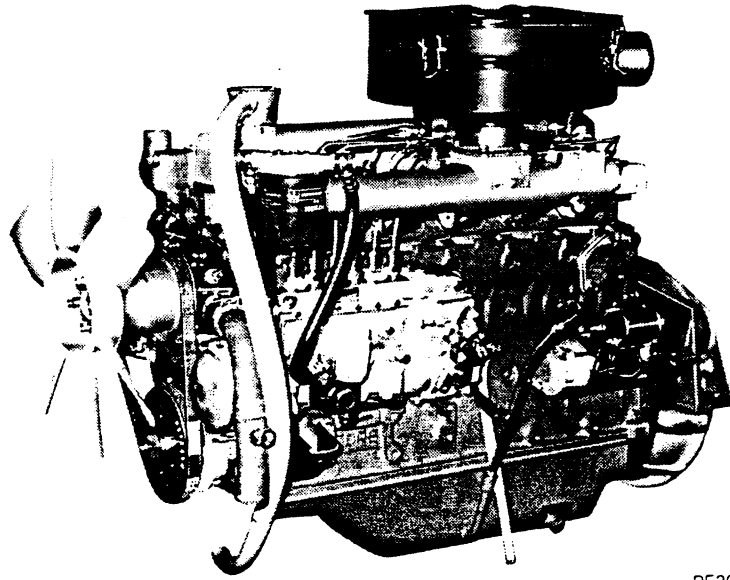

PE2059

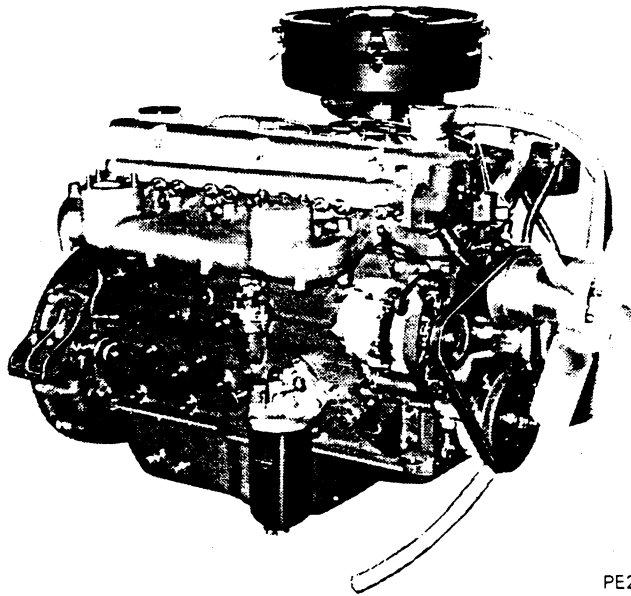

PE2060

2. MAJOR SPECIFICATIONS

2-1 Major Specifications

Item	Specifications				
Model	4D31	4D31-T	4D30	4DR5	6DR5
Combustion method	Direct injection	Direct injection (with turbo-charger)	Swirl chamber	←	←
No. and arrangement of cylinder	4 in-line	←	←	←	6 in-line
Cylinder bore x stroke mm	100 x 105	←	←	92 x 100	←
Total displacement cc	3 298	←	←	2 659	3 988
Empty weight kg*	320	330	320	255	370

* Empty weight as measured according to Mitsubishi Motors Corporation standard

2-2 Engine Outputs Classified by Application

Engine model Appli- cation	4D31	4D31-T		4D30	4DR5	6DR5
		Medium speed	High speed			
Intermittent rated output kW(HP)/rpm	31.0(41.6) /1 500	42.0(56.3) /1 500	39.5(53.0) /1 500	30.5(40.9) /1 500	22.5(30.2) /1 500	34.0(45.6) /1 500
	37.5(50.3) /1 800	52.0(69.7) /1 800	50.5(67.7) /1 800	37.5(50.3) /1 800	28.0(37.5) /1 800	41.5(55.6) /1 800
	41.5(55.6) /2 000	58.0(77.8) /2 000	57.0(76.4) /2 000	41.5(55.6) /2 000	31.5(42.2) /2 000	46.5(62.4) /2 000
	45.5(61.0) /2 200	63.5(85.1) /2 200	63.0(84.5) /2 200	45.5(61.0) /2 200	34.5(46.2) /2 200	51.5(69.1) /2 200
	51.0(68.4) /2 500	67.0(89.8) /2 500	69.5(93.2) /2 500	51.0(68.4) /2 500	39.0(52.3) /2 500	58.0(77.8) /2 500
	55.5(74.4) /2 800		73.5(98.6) /2 800	55.0(73.7) /2 800	43.0(57.6) /2 800	64.0(85.8) /2 800
	58.5(78.4) /3 000		75.5(101) /3 000	58.5(78.4) /3 000	45.5(61.0) /3 000	67.0(89.8) /3 000
Continuous rated output kW(HP)/rpm	28.0(37.5) /1 500	38.0(50.9) /1 500	36.0(48.3) /1 500	27.5(36.9) /1 500	20.5(27.5) /1 500	31.0(41.6) /1 500
	34.0(45.6) /1 800	47.0(63.0) /1 800	46.0(61.7) /1 800	34.0(45.6) /1 800	25.5(34.2) /1 800	38.0(50.9) /1 800
	37.5(50.3) /2 000	52.5(70.4) /2 000	52.0(69.7) /2 000	37.5(50.3) /2 000	28.5(38.2) /2 000	42.5(57.0) /2 000
	41.5(55.6) /2 200	57.5(77.1) /2 200	57.0(76.4) /2 200	41.0(55.0) /2 200	31.5(42.2) /2 200	47.0(63.0) /2 200
	43.0(57.7) /2 300	58.5(78.4) /2 300	59.5(79.8) /2 300	43.0(57.6) /2 300	33.0(44.2) /2 300	49.0(65.7) /2 300
	46.5(62.3) /2 500	61.0(81.8) /2 500	63.0(84.5) /2 500	46.0(61.7) /2 500	35.5(47.8) /2 500	53.0(71.1) /2 500
	53.0(71.1) /3 000		68.5(91.8) /3 000	53.5(71.7) /3 000	41.0(55.0) /3 000	61.5(82.5) /3 000

NOTE: 1. The output (SAE, gross) is corrected to standard ambient conditions based on SAE J1349.

2. The continuous rated output allows 10% (one hour) overload operation.

3. ENGINE NUMBERS, NAMEPLATE, CAUTION PLATE

(1) Engine Number

The engine number is stamped on the position as illustrated.

Ex.: 4D31 - 472830
 ↑ ↑
 Engine model Engine number

The engine number is important in knowing the history of the engine.

<D3, 4DR5>

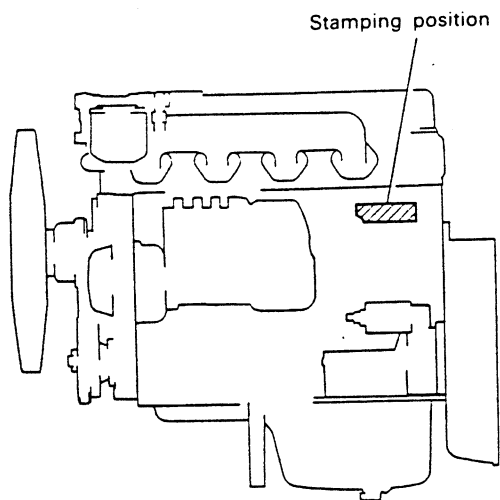

B1473A

<6DR5>

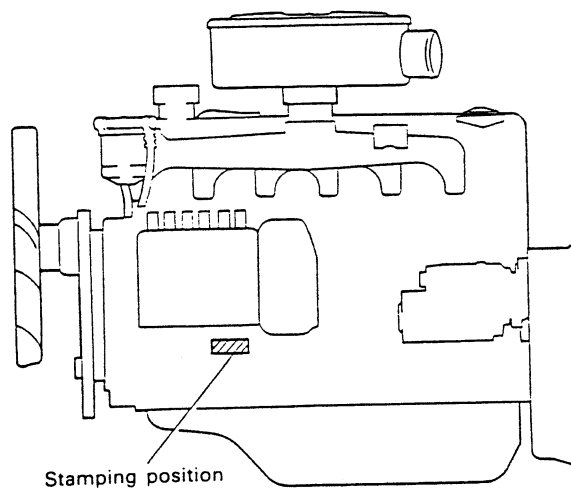

B1474A

(2) Nameplate and Caution Plate

The nameplate <DR> and caution plate are located as illustrated. The nameplate bears the engine model, total displacement and output. The caution plate bears the valve clearance, fuel injection sequence and timing.

<D3>

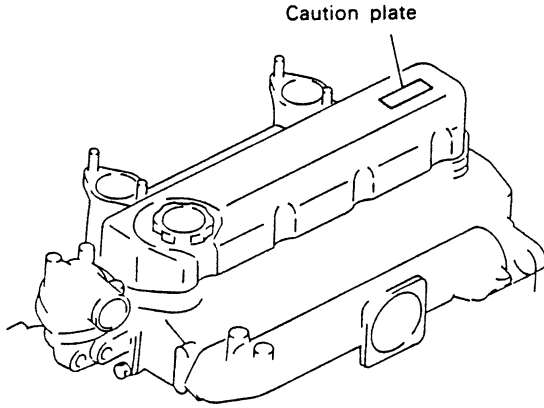

B1475A

<DR>

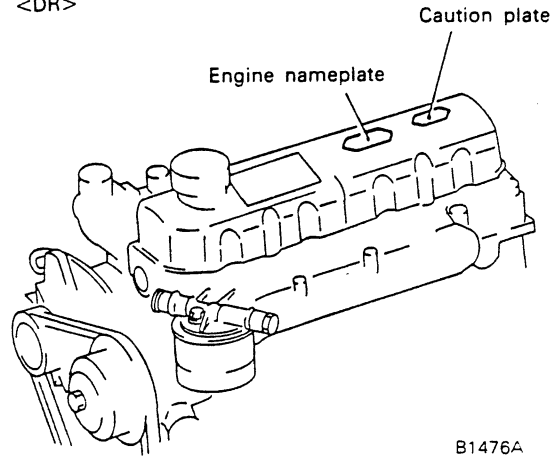

B1476A

- 1 Engine model
- 2 Total displacement
- 3 Rated output
- 4 Engine speed

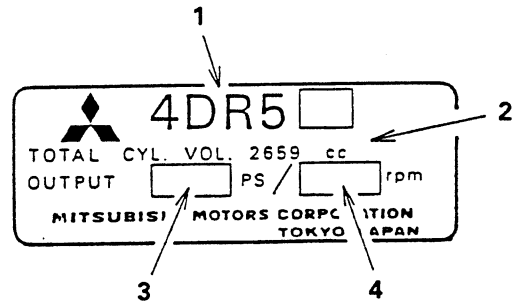

B1477A

4. GENERAL BOLTS AND NUTS TIGHTENING TORQUE TABLE

Unless otherwise specified, the parts and equipment of vehicle must be tightened by the following standard bolts and nuts. Tightening torques for these bolts and nuts are shown below.

NOTE: Threads and seat surfaces must be in dry state.

Standard Bolts and Nuts

Unit: N m (kgf m)

Dia. mm	Pitch mm	4T (Head mark 4 or ○)	7T (Head mark 7 or ○)	8T (Head mark 8 or ⊕)
5	0.8	2.0 to 2.9 (0.2 to 0.3)	3.9 to 5.9 (0.4 to 0.6)	4.9 to 6.9 (0.5 to 0.7)
6	1.0	3.9 to 5.9 (0.4 to 0.6)	6.9 to 10.8 (0.7 to 1.1)	7.8 to 11.8 (0.8 to 1.2)
8	1.25	8.8 to 13.7 (0.9 to 1.4)	16.7 to 25.5 (1.7 to 2.6)	19.6 to 29.4 (2.0 to 3.0)
10	1.25	18.6 to 27.5 (1.9 to 2.8)	34.3 to 53.9 (3.5 to 5.5)	44.1 to 58.8 (4.5 to 6.0)
	1.5	17.7 to 26.5 (1.8 to 2.7)	32.4 to 49.0 (3.3 to 5.0)	42.1 to 58.8 (4.3 to 6.0)
12	1.25	33.3 to 49.0 (3.4 to 5.0)	68.6 to 93.2 (7.0 to 9.5)	83.4 to 108 (8.5 to 11)
	1.75	30.4 to 46.1 (3.1 to 4.7)	63.7 to 83.4 (6.5 to 8.5)	73.5 to 98.1 (7.5 to 10)
14	1.5	58.8 to 83.4 (6.0 to 8.5)	118 to 157 (12 to 16)	127 to 177 (13 to 18)
	2.0	53.9 to 73.5 (5.5 to 7.5)	108 to 137 (11 to 14)	118 to 167 (12 to 17)
16	1.5	93.2 to 127 (9.5 to 13)	177 to 235 (18 to 24)	196 to 265 (20 to 27)
	2.0	88.3 to 118 (9.0 to 12)	157 to 216 (16 to 22)	186 to 255 (19 to 26)



Suggest:

For more complete manuals. Please go to the home page.

<https://www.ebooklibonline.com>

If the above button click is invalid. Please download this document first, and then click the above link to download the complete manual.

Thank you so much for reading

Flange Bolts and Nuts

Unit: N m (kgf m)

Dia. mm	Pitch mm	4T (Head mark 4 or ○)	7T (Head mark 7 or ○)	8T (Head mark 8 or ⊕)
6	1.0	3.9 to 5.9 (0.4 to 0.6)	7.8 to 11.8 (0.8 to 1.2)	8.8 to 13.7 (0.9 to 1.4)
8	1.25	9.8 to 14.7 (1.0 to 1.5)	18.6 to 27.5 (1.9 to 2.8)	21.6 to 32.4 (2.2 to 3.3)
10	1.25	20.6 to 30.4 (2.1 to 3.1)	38.2 to 58.8 (3.9 to 6.0)	49.0 to 63.7 (5.0 to 6.5)
12	1.25	37.3 to 53.9 (3.8 to 5.5)	78.5 to 108 (8.0 to 11)	88.3 to 118 (9.0 to 12)

GROUP 11 ENGINE

CONTENTS

- 1. GENERAL 11- 1
 - 1-1 Engine Proper 11- 1
 - 1-2 Air Compressor <Option: 4D31> 11- 9
 - 1-3 Flywheel PTO <Option: 4D31> 11-11
- 2. SPECIFICATIONS 11-12
- 3. SERVICE STANDARDS 11-14
 - 3-1 Service Standard Table 11-14
 - 3-2 Tightening Torque Table 11-20
- 4. SPECIAL TOOLS 11-21
- 5. SERVICE PROCEDURES 11-30
 - 5-1 Engine Proper 11-30
 - 5-1-1 Measurement of Compression Pressure 11-30
 - 5-1-2 Cylinder Head and Valve Mechanism . 11-32
 - 5-1-3 Flywheel and Rear Plate 11-50
 - 5-1-4 Timing Gear and Camshaft 11-56
 - 5-1-5 Crankcase and Main Moving Parts ... 11-70
 - 5-1-6 Inspection and Adjustment of Valve Clearance 11-92
 - 5-2 Air Compressor <Option: 4D31> 11-94
 - 5-2-1 Removal and Installation 11-94
 - 5-2-2 Disassembly and Inspection 11-95
 - 5-2-3 Reassembly 11-96
 - 5-3 Flywheel PTO <Option: 4D31> 11-97
 - 5-3-1 Disassembly and Inspection 11-97
 - 5-3-2 Reassembly 11-98
- 6. TROUBLESHOOTING 11-99

<https://www.ebooklibonline.com>

Hello dear friend!

Thank you very much for reading.

Enter the link into your browser.

The full manual is available for immediate download.

<https://www.ebooklibonline.com>