

KOBELCO

SERVICE MANUAL

mitsubishi DIESEL ENGINE

6D2

(For industrial use)

Applicable Engine Models: 6D24, 6D24-T, 6D25-TC, 6D24-TL

6D2

diesel engine

Shop Manual

FOREWORD

This shop manual contains the specification, construction, operation, adjustment and service procedures of the Model 6D2 diesel engine for service mechanics engaged in servicing of the Mitsubishi diesel engines.

Please make the most of this shop manual to perform correct servicing and wasteless operations.

Note that some of the contents of this shop manual are subject to change owing to improvements, etc. that may be introduced after publication of this shop manual.

FEBRUARY 2001

Applicable Engine Models

6D24
6D24-T
6D24-TC
6D24-TL

GROUP INDEX

GENERAL	00
ENGINE	11
LUBRICATION	12
FUEL AND ENGINE CONTROL	13A
ELECTRONICALLY CONTROLLED FUEL SYSTEM	13E
COOLING	14
INTAKE AND EXHAUST	15
ENGINE ELECTRICAL	16
CLUTCH	21
SPECIAL EQUIPMENT	61

COMPILATION OF THIS MANUAL

CONTENTS

1. TERMS AND UNITS	4
2. UNITS	5
3. READING THE ILLUSTRATION	6

<https://www.ebooklibonline.com>

Hello dear friend!

Thank you very much for reading.

Enter the link into your browser.

The full manual is available for immediate download.

<https://www.ebooklibonline.com>

COMPILATION OF THIS MANUAL – TERMS AND UNITS

1. TERMS AND UNITS

The following terms and units are used throughout the entire texts of this manual.

(1) Front and rear

The terms “front” is the fan side and “rear” the flywheel side of the engine.

(2) Right and left

The terms “right” and “left” shall be used to indicate the side as viewed from the flywheel side of the engine.

(3) Service standard terms

- Nominal value

Shows the nominal dimensions, dimension of an individual part, standard clearance between parts in an assembly, or the standard performance of an assembly.

- Limit

Shows the value of a part at which the part is no longer serviceable from the performance as well as strength viewpoints, requiring replacement or repair.

(4) Tightening torque

Over- or undertightening of bolts and nuts has critical effects on performance and functions. Tightening torque is therefore specified for some tightening points.

All tightening torque specifications may be considered as “dry” unless “wet” is specified.

Where no tightening torque is specified, use a torque value specified in the General Bolts and Nuts Tightening Torque Table.

(5) Units

Length, weight, surface area and capacity are given in International Systems of Units with metric units indicated in ().

Temperatures are given in degrees Celsius.

For the conversion into the foot-pound system, refer to the following conversion table.

COMPILATION OF THIS MANUAL – UNITS

2. UNITS

Tightening torques and other parameters are given in SI* units with metric units added in brackets { }.

***SI: Le Système International d'Unités**

Example: 390 N · m {40 kgf · m}

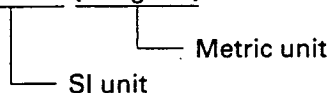

Unit	SI unit {metric unit}	Conversion factor
Force	N {kgf}	9.80665 N {1 kgf}
Moment of force	N · m {kgf · m}	9.80665 N · m {1 kgf · m}
Pressure	Positive pressure	kPa {kgf/cm ² }
	Vacuum pressure	kPa {mmHg}
		Pa {mmH ₂ O}
Volume	dm ³ {L}	1 dm ³ {1 L}
Power	kW {PS}	0.7355kW {1 PS}
Heat quantity	J {kcal}	4186.05 J {1 kcal}
Heat flow	W {kcal/h}	1.16279 W {1 kcal/h}
Angle	°	-
Temperature	°C	-
Electric current	A	-
Voltage	V	-
Resistance	Ω	-
Electric power	W	-

Unit	SI unit	Foot-pound unit	Conversion rate
Force	N (Newton)	lbf	1 N = 0.2248 lbf
Moment of force	N · m	ft.lbs	1 N · m = 0.7375 ft.lbs
Pressure	kPa (kilopascal)	psi	1 kPa = 0.145 psi 1 kPa = 0.2953 in. Hg
Volume	L	gal.	1 L = 0.2642 gal. (U.S.) 1 L = 0.220 gal. (imp.)
	cm ³	oz	1 cm ³ = 0.033814 oz (U.S.)
	cm ³	cu.in.	1 cm ³ = 0.035195 oz (imp.) 1 cm ³ = 0.061023 cu.in.
Power	kW (kilowatt)	PS	1 kW = 1.3596 PS
Temperature	°C	°F	t°C = (1.8t°C + 32)°F
Mass quantity of matter	kg	lb	1 kg = 2.2046 lb
	g	oz	1 g = 0.035274 oz
Dimension	m	ft.	1 m = 3.2808 ft.
	mm	in.	1 mm = 0.03937 in.

COMPILATION OF THIS MANUAL – READING THE ILLUSTRATION

3. READING THE ILLUSTRATION

(Ex. 1: Disassembly and Inspection)

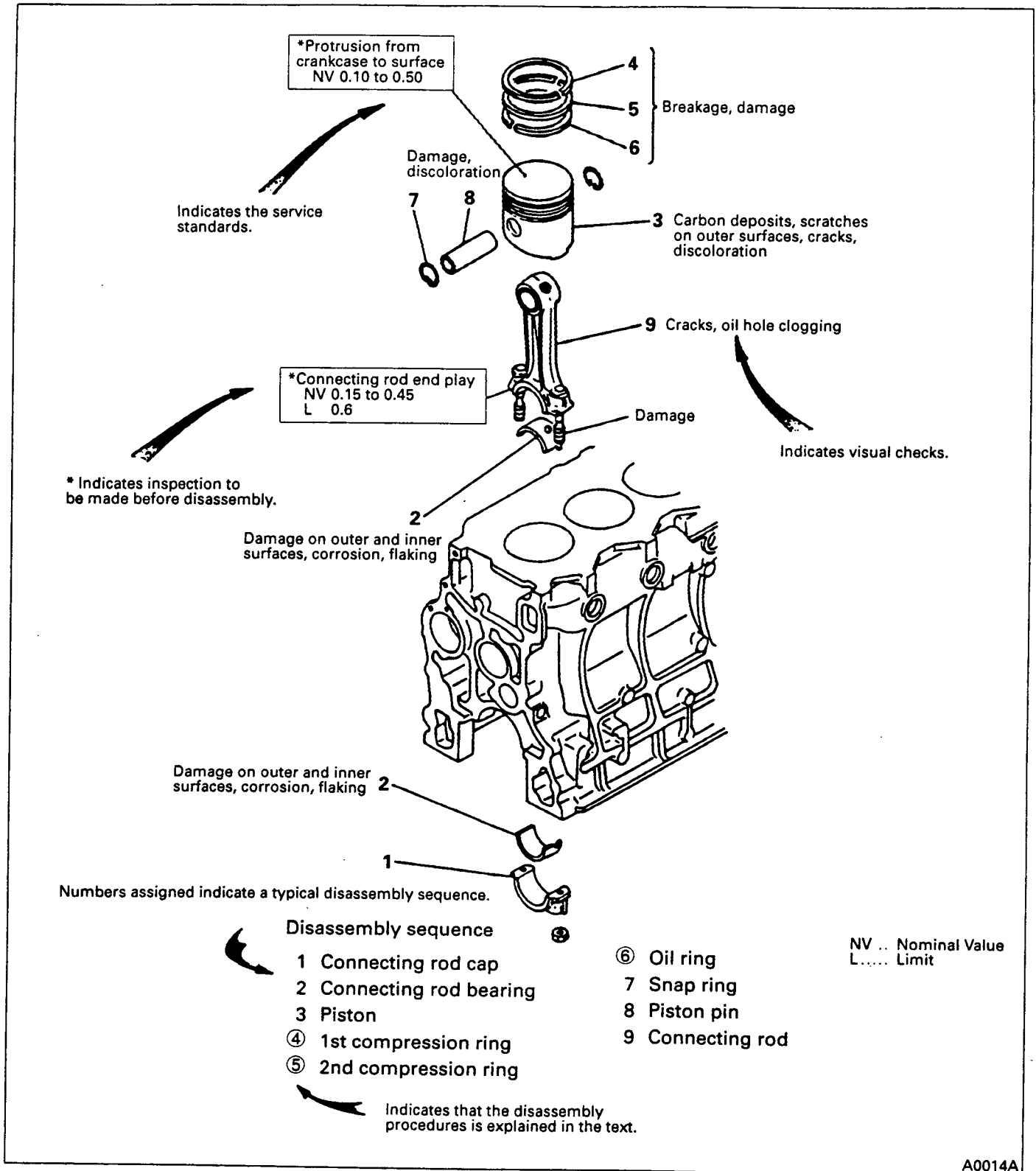

A0014A

COMPILATION OF THIS MANUAL – READING THE ILLUSTRATION

(Ex. 2: Reassembly)

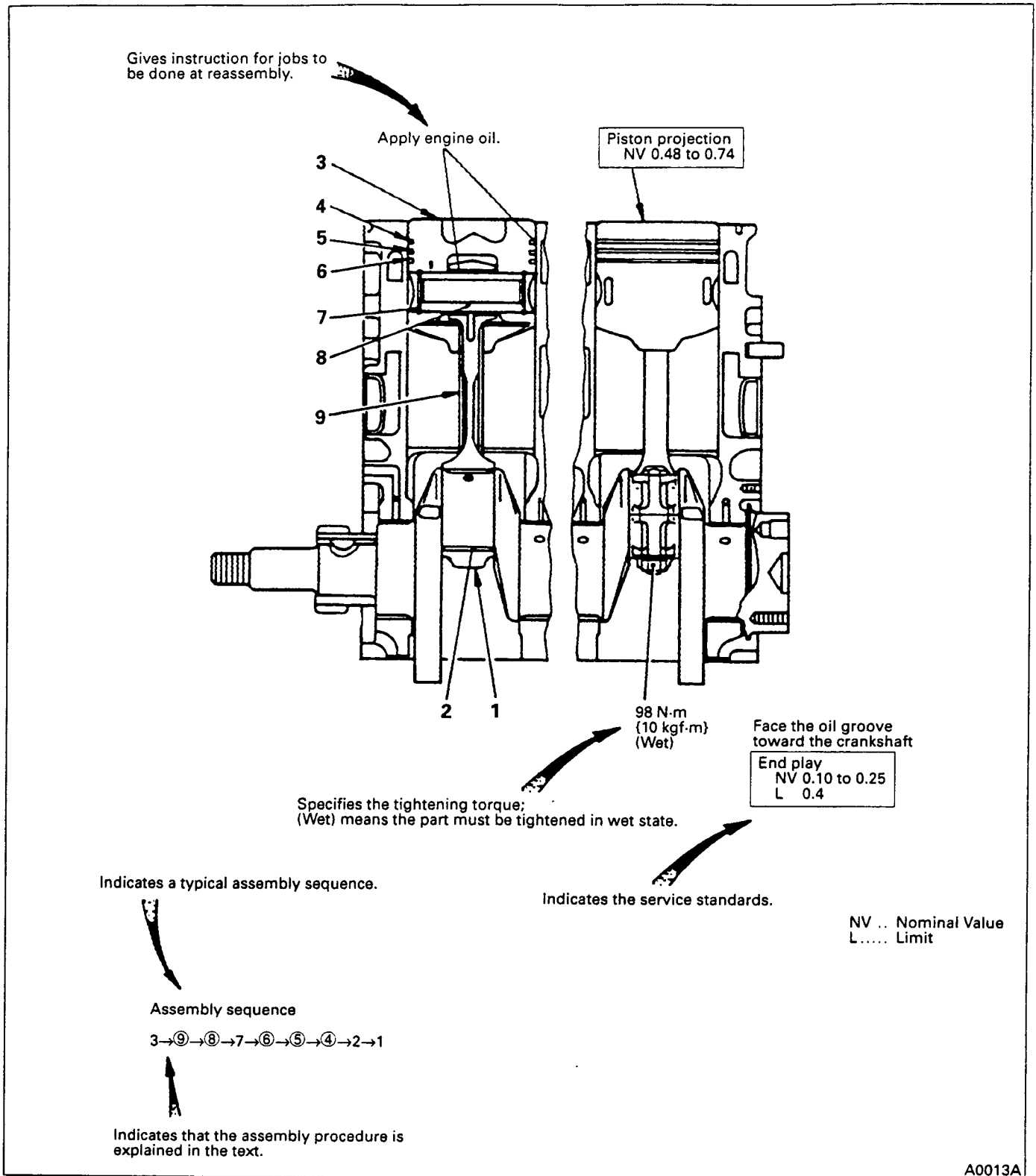

Illustrations (exploded views and assembly drawings) shows a typical service procedures if it is identical

among various types of available systems and units.

NOTES

GENERAL

CONTENTS

1. EXTERNAL VIEW	2	4. KEY POINTS FOR	
2. MAJOR SPECIFICATIONS	3	MAINTENANCE WORK	5
2.1 Major Specifications	3	5. GENERAL BOLTS AND NUTS	
2.2 Engine Outputs Classified by		TIGHTENING TORQUE TABLE	12
Application	3		
3. ENGINE NUMBER AND CAUTION			
PLATE	4		

1. EXTERNAL VIEW

Natural-aspirated engine

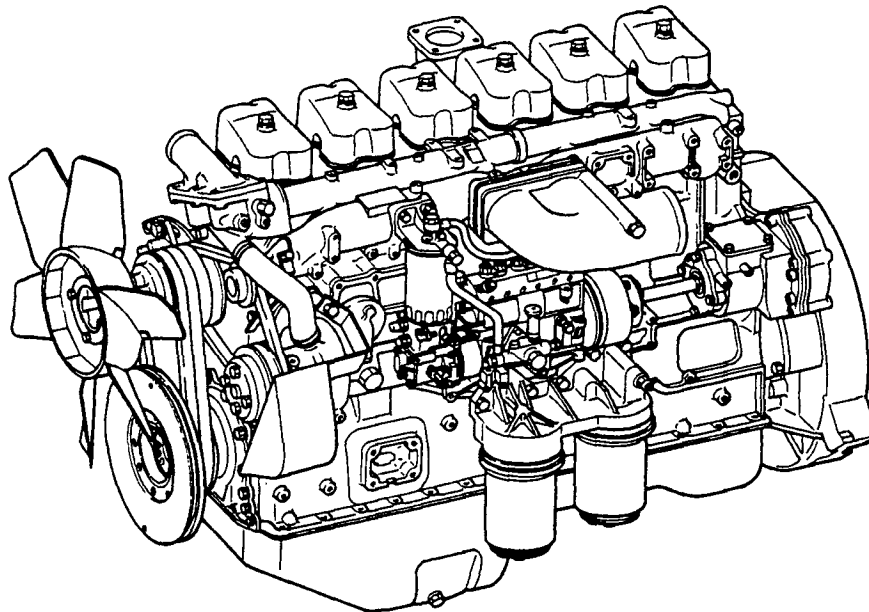

Turbocharged engine

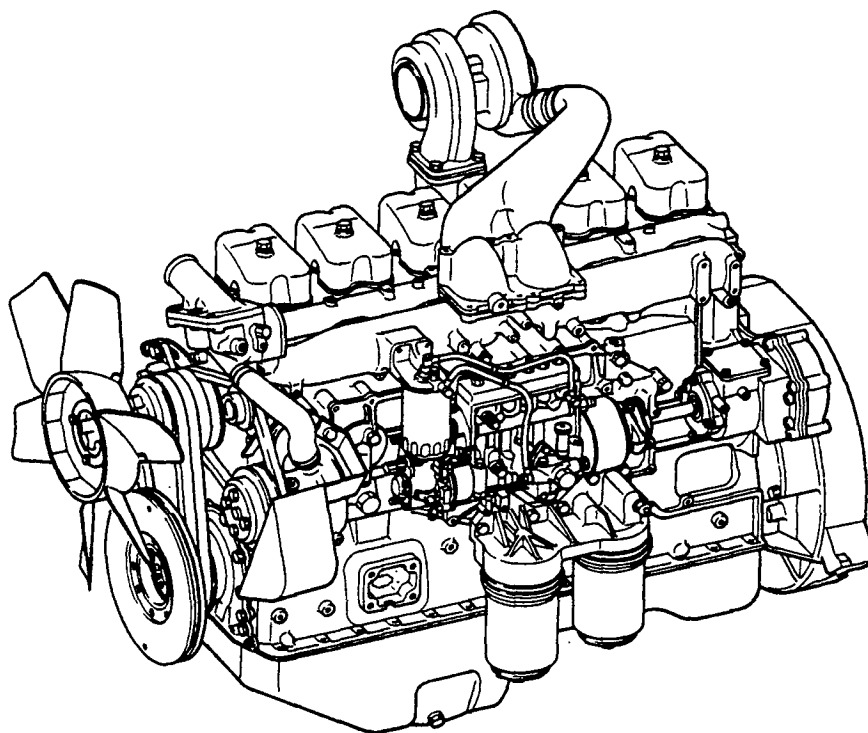

A0243A

A0244A

2. MAJOR SPECIFICATIONS

2.1 Major Specifications

Item \ Engine model	6D24	6D24-T	6D24-TC	6D24-TL
Type	Diesel, 4-cycle, water-cooled			
Combustion method	Direct injection			
No. and arrangement of cylinder	6, in-line			
Cylinder bore x stroke mm	130 x 150			
Total displacement cm ³	11945			
Engine dimension (with fan)				
Overall length mm	1473	1473	1473	1473
Overall width mm	866	881	881	869
Overall height mm	1058	1169	1209	1246
Empty weight kg*	905	930	960	940

* Empty weight as measured according to Mitsubishi Motors Corporation standard.

2.2 Engine Outputs Classified by Application

Application \ Engine model \ Engine speed rpm	6D24	6D24-T Turbocharged	6D24-TC Turbocharged with Aftercooler
Intermittent rated output kW (PS)	1500	114 {115}	163 {222}
	1800	136 {185}	191 {260}
	2000	144 {196}	201 {273}
	2200	151 {205}	206 {280}
Continuous rated output kW (PS)	1500	104 {141}	148 {202}
	1800	124 {168}	174 {236}
	2000	131 {178}	182 {248}
	2200	137 {186}	187 {255}

NOTE:

1. The output (SAE, gross) is corrected to standard ambient conditions based on SAE J1349.
2. The continuous rated output allows 10% (one hour) overload operation.

3. ENGINE NUMBER AND CAUTION PLATE

(1) Engine number

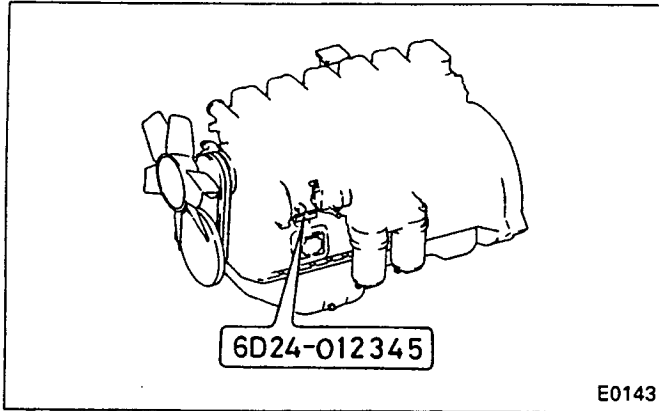

The engine number is stamped near the front of the crankcase on the left-hand side. It takes the following form:

Example: 6D24 – 012345

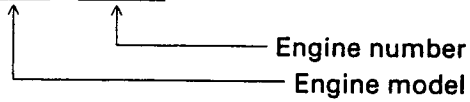

The engine number is important in knowing the history of the engine.

(2) Caution plate

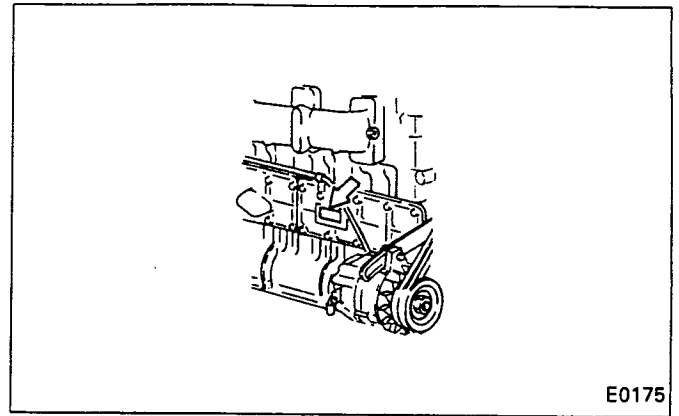

The caution plate is attached to the portion shown in the illustration. The caution plate indicates the following items.

VALVE CLEARANCE (COLD)		
INLET	0.4 mm (0.016 in)	1
EXHAUST	0.6 mm (0.024 in)	1
FIRING ORDER	1-5-3-6-2-4	2
FUEL INJECTION TIMING	<input type="checkbox"/> ° BTDC	3

- 1 Valve clearance
- 2 Firing order
1-5-3-6-2-4
- 3 Fuel injection timing

A0166B

4. KEY POINTS FOR MAINTENANCE WORK

In order to determine the condition of the vehicle adequately, attend the vehicle beforehand to find and keep record of the accumulated mileage, operating condition, what the customer's demand is, and other information that may be necessary.

Prepare the steps to be taken and perform efficient and wasteless maintenance procedure.

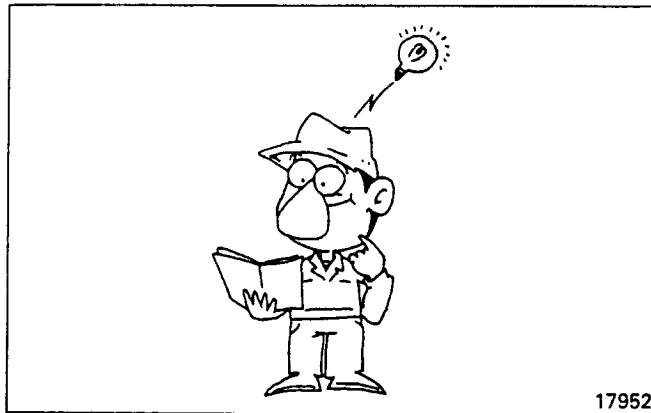

- Determine where the fault exists and check for the cause to see whether removal or disassembly of the part is necessary. Then follow the procedure specified by this manual.
- Perform maintenance work at a level area.

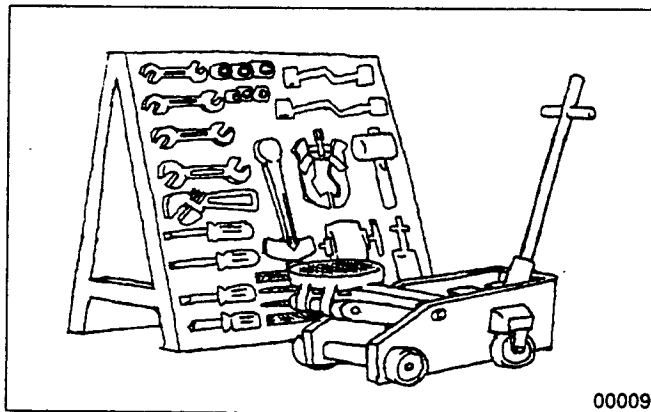

- Prepare general and special tools necessary for the maintenance work.

WARNING  _____
Do not attempt to use tools other than special tools where use of special tools is specified in this manual. This will avoid injury or damage.

- When removing or installing the engine, attach the lifting wire rope hooks to the engine's lifting eyes and hoist the engine slowly such that it does not touch other components.

WARNING  _____
Check that the wire rope and crane are sufficiently strong.

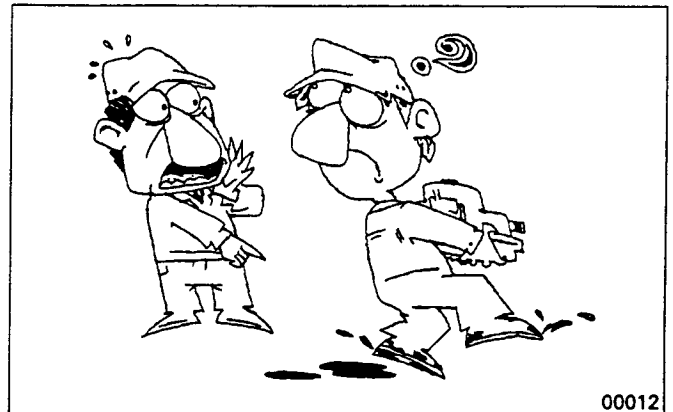

- Be particularly careful not to work in shoes that have oily soles and are slippery. When working as a team of two or more, arrange signals in advance and keep confirming safety. Be careful not to accidentally bump switches or levers.
- Check for oil leakage before cleaning the area having the fault otherwise you might miss detecting the leakage.
- Prepare replacement part(s) beforehand.

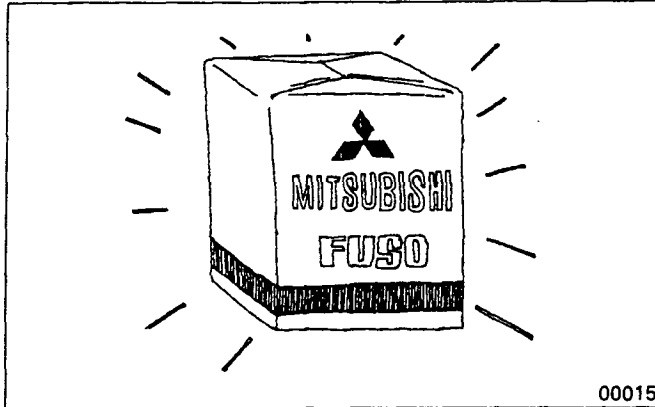

00015

- Replace oil seals, packing, O-rings and other rubber parts; gaskets and split pins with new parts whenever any of them has been removed. Use only genuine MITSUBISHI replacement parts.

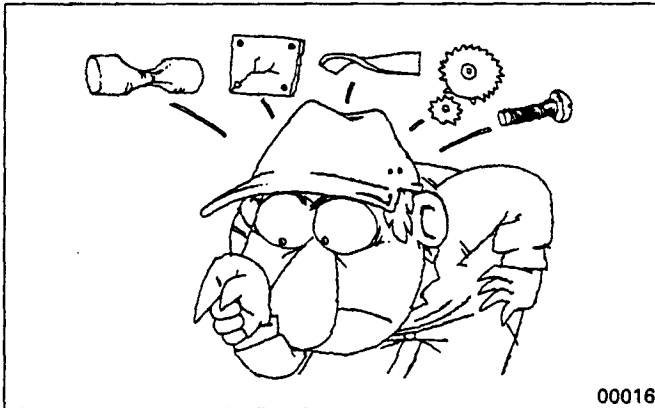

00016

On disassembly, visually inspect all parts for wear and tear, cracks, damage, deformation, degradation, rust, corrosion, smoothness in rotation, fatigue, clogging and any other possible defect.

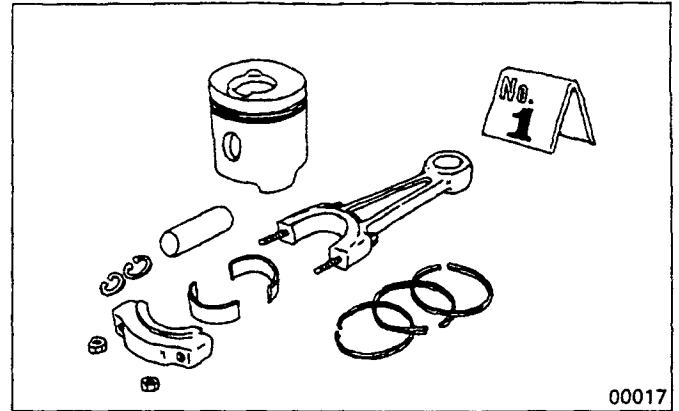

00017

Put alignment marks on part combinations before disassembly and arrange the disassembled parts neatly. This will help avoid mismatching of the parts later. Put the alignment marks, punch marks, etc. where performance and appearance will not be affected. Cover the area left open after removal of parts to keep it free from dust.

CAUTION ⚠

- Take care to avoid mixing up numerous parts, similar parts, left and right, etc.
- Keep new parts for replacement and original (removed) parts separate.

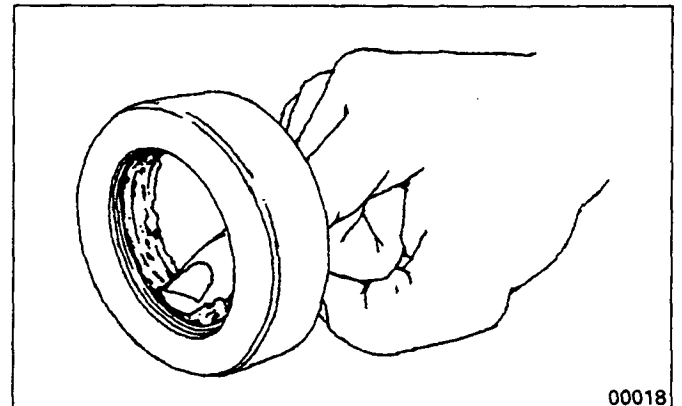

00018

Apply the specified oil or grease to U-packings, oil seals, dust seals and bearings during assembly.

CAUTION ⚠

Use only the specified oil, grease, etc. for lubricant. Remove the excess immediately after application with a piece of rag.

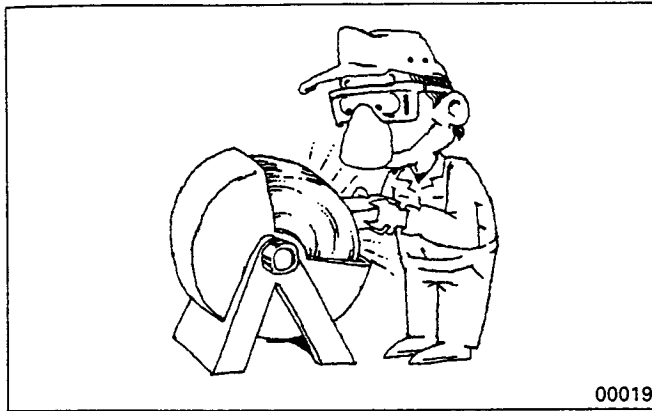

00019

Wear goggles when using a grinder or welder. Pay full attention to safety by wearing gloves when necessary. Watch out for sharp edges, etc. that might injure your hands or fingers.

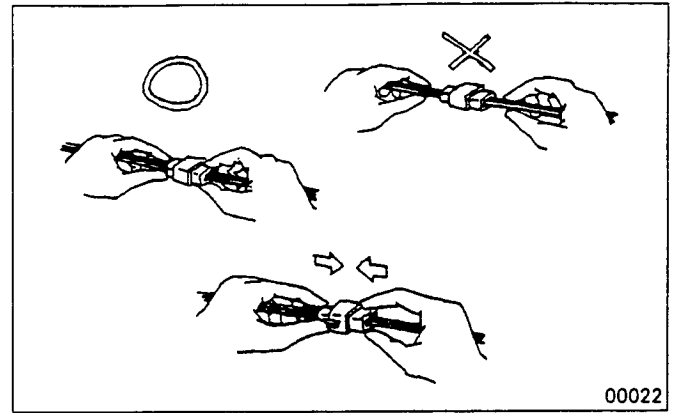

00022

- Pull the connector, and not the harness lead, to separate connectors. To separate a lock-type connector, first push toward arrow mark. To reconnect a lock-type connector, press the separated parts until they click together.

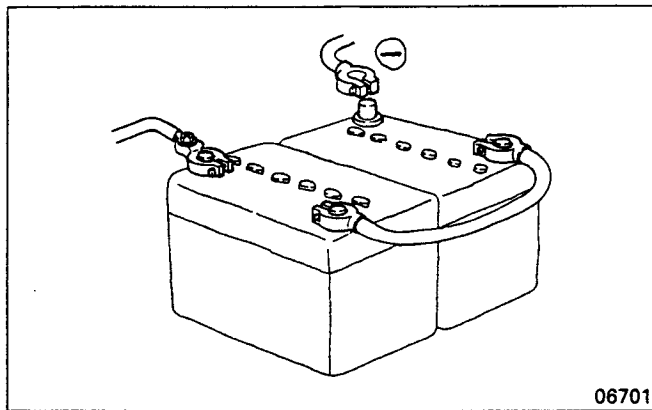

06701

Before carrying out maintenance work on the electric system, disconnect the negative terminals of the batteries.

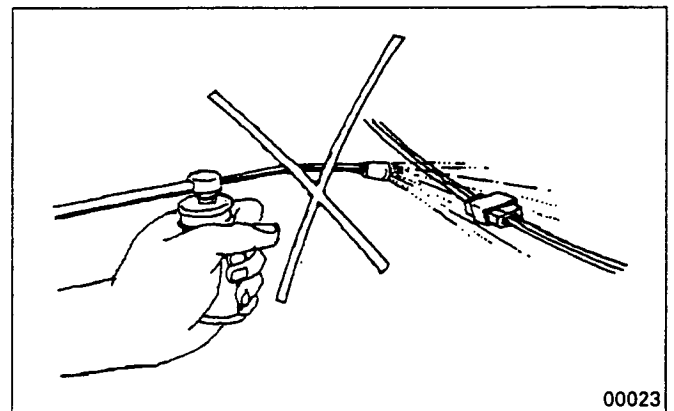

00023

- When washing the vehicle, cover the electric system parts and instruments with waterproof material beforehand (Cover with vinyl sheet or the like). Keep water away from harness wire connectors and sensors. If any of them should get wet, wipe them off immediately.

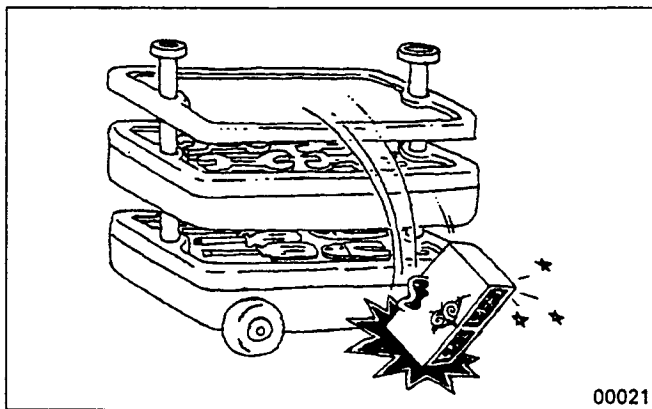

00021

- Take care when handling sensors, relays, etc. which are vulnerable to shock and heat.

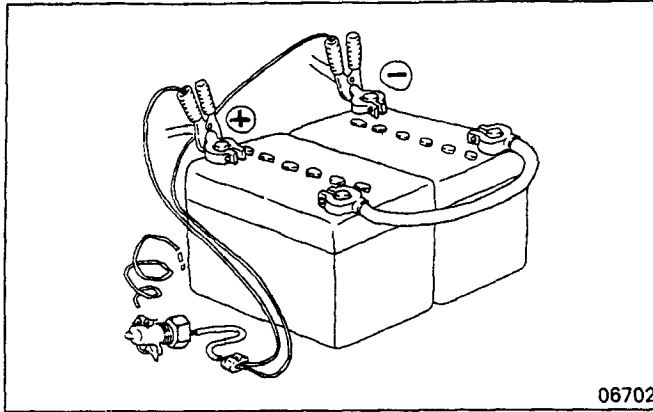

06702

- To apply voltage for testing, check that the positive and negative cables are connected properly, then increase voltage gradually from 0 volt. Do not apply voltage higher than the specified value. In particular, pay close attention to the electronic control unit and sensors, since they are not always supplied with 24V.

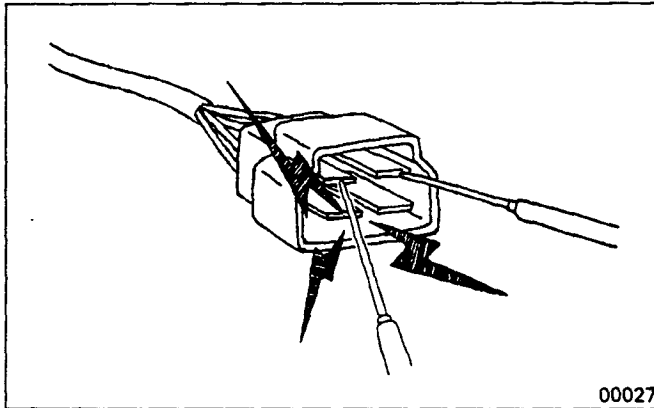

00027

- When using testers or the like for continuity tests, be careful not to allow test probes to touch the wrong terminals.

Measurement Procedures Using Connectors

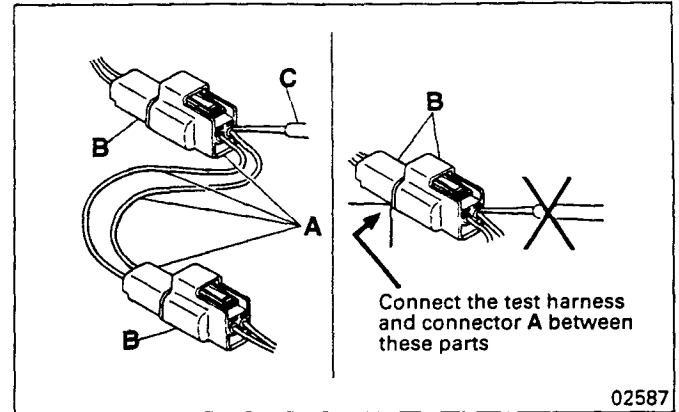

02587

Test with connectors engaged (continuity through circuit obtained)

<Waterproof connector>

Prepare a test harness and connectors A, then connect it between the two parts of harness B that is to be tested. Check the circuit by touching test probe C to the test connector.

Never insert the test probe from the harness side of the waterproof connection, or waterproof performance might be diminished causing corrosion of the connector.

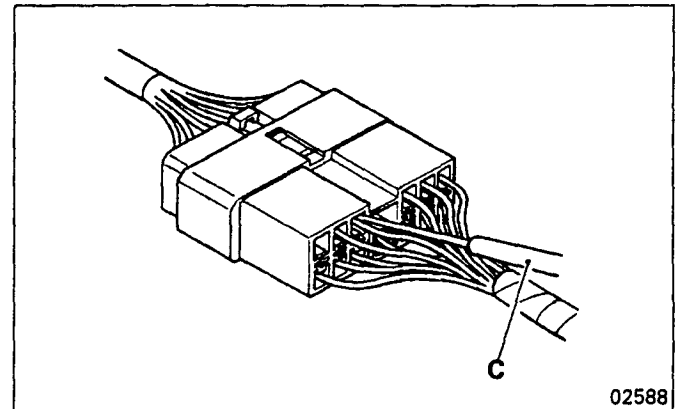

02588

<Non-waterproof connector>

Insert test probe C from the harness side of the connector. Where control units, etc. have connectors that are too small to accept the test probe, do not force the test probe into them.

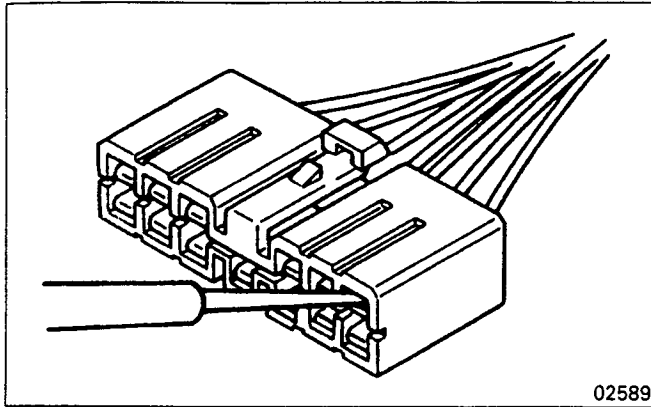

Test with connectors disengaged

Using female pins

Insert a test probe into a terminal. However, do not force the probe into the terminal, or it will cause a poor contact.

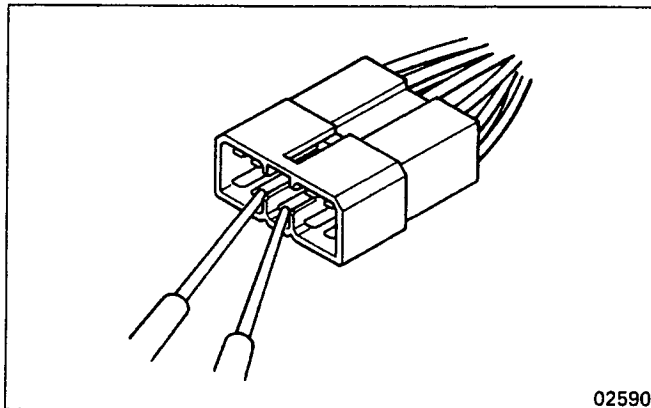

Using male pins

Touch the pins directly using test probes.

CAUTION ⚠

Be sure that you do not short circuit the connector pins when you use the test probe because this could damage the internal circuit of the electronic control unit.

Connector Inspection Procedures

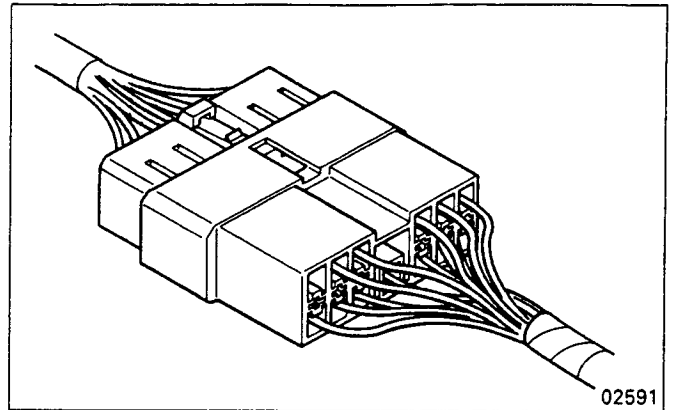

Visual inspection

Check for loose connection and poor engagement.

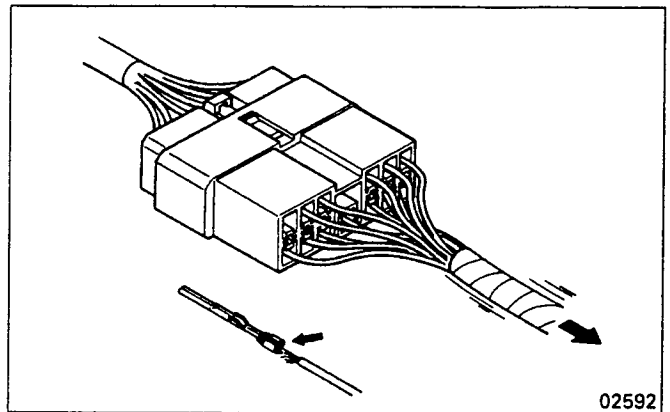

Check if harnesses are broken by pulling gently around the terminals.

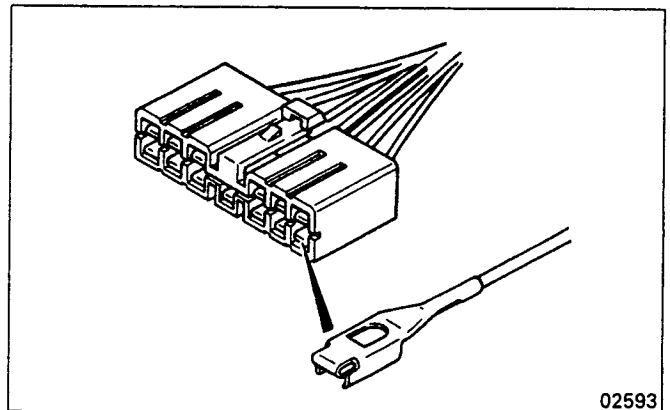

Check for a decrease in contact pressure between the male and female terminals.

Check for poor contact caused by connector pins having fallen out, rusted terminals or foreign particles.

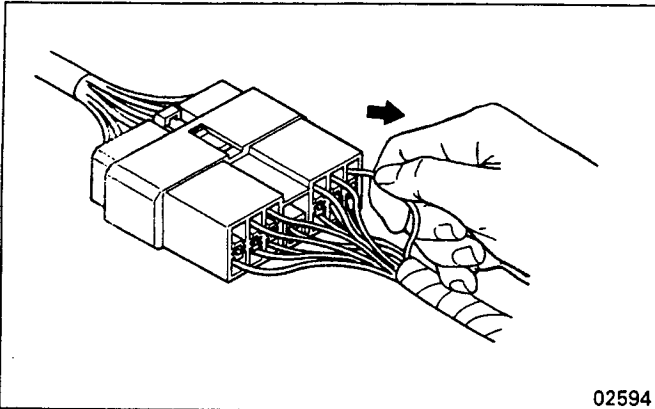

02594

Connector pin fall out inspection

Damaged connector pin stoppers can cause poor engagement of the terminals (male and female pins) even if the connector body is secured, and might cause some pins to fall out. Check if the pins have fallen out from the connector by pulling each harness gently.

Inspection Procedures for Blown Fuses

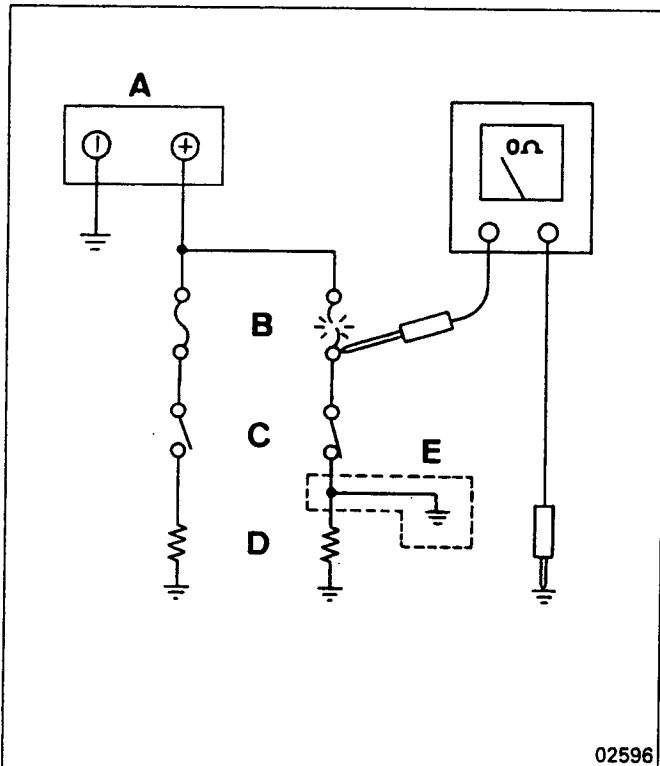

02596

Remove fuse **B** and measure resistance between the loaded side of the fuse and ground.

Turn on all circuit switches (connected to the fuse). If the resistance value reading is approximately 0, a short has occurred between the switch and the loaded point. A value of other than zero may indicate that the fuse was blown by a temporary short but the short is no longer present.

The major causes of a short circuit are as follows:

- Harness stuck onto the vehicle body.
- Harness sheath damaged by friction or heat.
- Water in connectors or circuits.
- Mistakes (accidental short circuits)

A: Battery

B: Fuse

C: Loaded switch

D: Load

E: Short circuit

Precautions for Handling Alternator

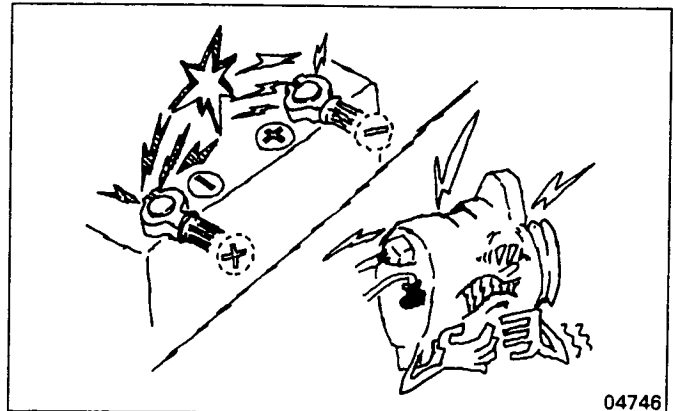

04746

When servicing the alternator, pay attention to the following:

- Do not connect the alternator with battery polarities reversed. If the alternator is connected with reversed polarities, a large current flow from the battery to the alternator occurs, and the diode or regulator might be damaged.

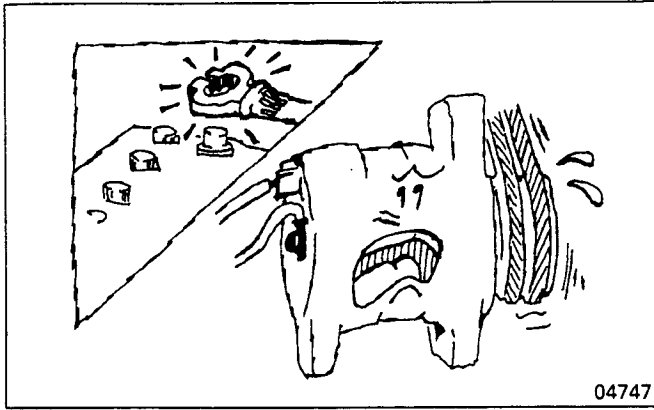

04747

- While the engine is running, do not remove the battery terminals. If the battery terminals are removed at that time, a surge voltage is generated and the diode or regulator might be weakened.

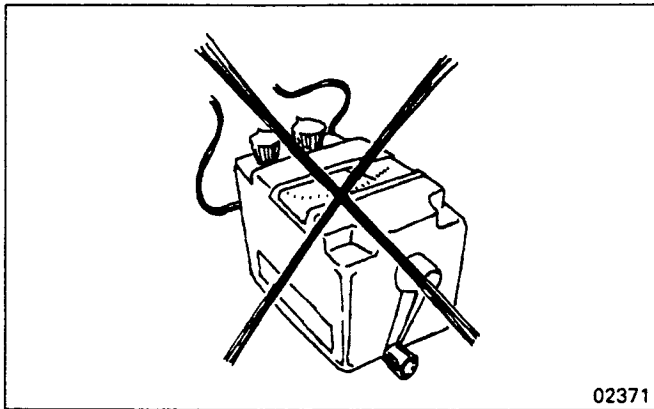

02371

- Do not use a high-voltage tester such as a megger for inspection. If a high-voltage tester is used, the diode or regulator might be destroyed.

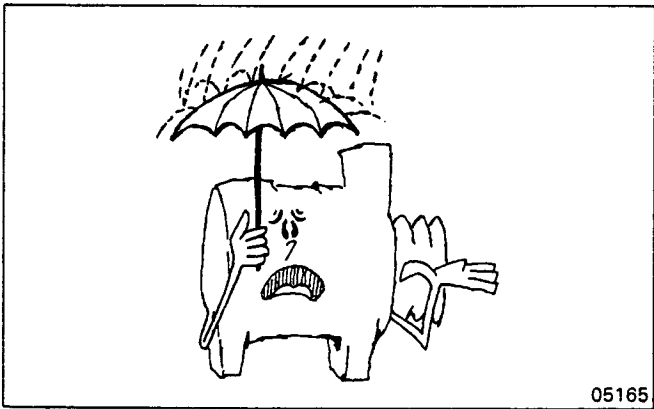

05165

- Do not splash water over the alternator. If water is directly splashed over the alternator, individual components will be short-circuited and might be destroyed.

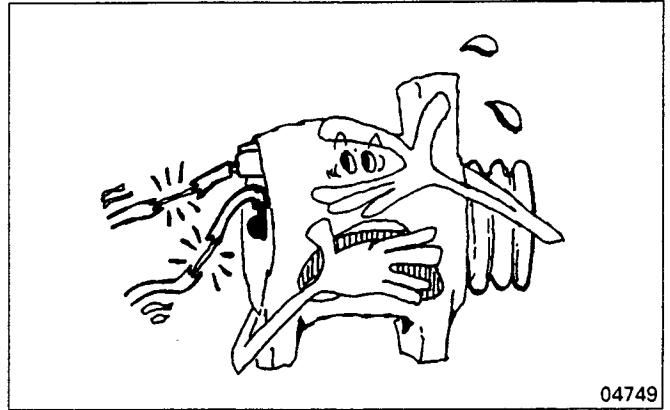

04749

- Do not short-circuit terminal B and terminal L while running the alternator. If the terminals are short-circuited while the alternator is running, the diode trio might be destroyed.

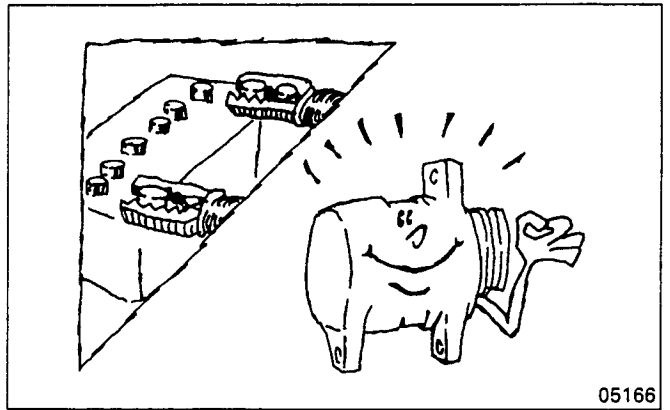

05166

- Disconnect the battery terminals before quick-charging the battery. Quick-charging without disconnecting the battery terminals might damage the diode or regulator.



Suggest:

For more complete manuals. Please go to the home page.

<https://www.ebooklibonline.com>

If the above button click is invalid. Please download this document first, and then click the above link to download the complete manual.







Thank you so much for reading

5. GENERAL BOLTS AND NUTS TIGHTENING TORQUE TABLE

- Use specified bolts and nuts and tighten them with the applicable torques according to the following table, unless otherwise specified.
- Threads and contact seats shall be dry.
- Where there is difference in strength classification between nut and bolt (or stud bolt), the torque specified for bolt shall apply.



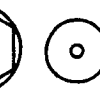



Hex-head Bolt and Stud Bolt

Unit: N·m (kgf·m)

Strength classification	4T		7T		8T	
Representation						
Diameter symbol	(Stud)		(Stud)		(Stud)	
M5	2 to 3 {0.2 to 0.3}	-	4 to 6 {0.4 to 0.6}	-	5 to 7 {0.5 to 0.7}	-
M6	4 to 6 {0.4 to 0.6}	-	7 to 11 {0.7 to 1.1}	-	8 to 12 {0.8 to 1.2}	-
M8	9 to 14 {0.9 to 1.4}	-	17 to 26 {1.7 to 2.6}	-	20 to 29 {2.0 to 3.0}	-
M10	19 to 28 {1.9 to 2.8}	18 to 26 {1.8 to 2.7}	36 to 52 {3.5 to 5.5}	33 to 49 {3.3 to 5.0}	45 to 60 {4.5 to 6.0}	41 to 59 {4.3 to 6.9}
M12	35 to 50 {3.4 to 5.0}	31 to 46 {3.1 to 4.7}	70 to 95 {7.0 to 9.5}	65 to 85 {6.5 to 8.5}	85 to 110 {8.5 to 11}	75 to 100 {7.5 to 10}
M14	60 to 85 {6.0 to 8.5}	55 to 75 {5.5 to 7.5}	120 to 160 {12 to 16}	110 to 140 {11 to 14}	130 to 180 {13 to 18}	120 to 160 {12 to 17}
M16	90 to 130 {9.5 to 13}	90 to 120 {9.0 to 12}	180 to 240 {18 to 24}	160 to 220 {16 to 22}	200 to 270 {20 to 27}	190 to 260 {19 to 26}
M18	140 to 190 {14 to 19}	120 to 160 {12 to 16}	260 to 340 {25 to 35}	220 to 290 {22 to 30}	290 to 390 {30 to 40}	260 to 340 {26 to 35}
M20	190 to 260 {19 to 26}	170 to 230 {17 to 23}	350 to 470 {36 to 48}	320 to 420 {32 to 43}	410 to 550 {41 to 56}	370 to 490 {37 to 50}
M22	260 to 340 {26 to 35}	230 to 300 {23 to 31}	470 to 640 {48 to 65}	430 to 570 {43 to 58}	550 to 740 {56 to 75}	490 to 670 {50 to 68}
M24	340 to 450 {34 to 46}	290 to 390 {29 to 40}	630 to 840 {63 to 86}	540 to 730 {55 to 74}	730 to 980 {74 to 100}	630 to 840 {64 to 86}





Hex-head Flange Bolt

Unit: N·m (kgf·m)

Strength classification	4T		7T		8T	
Representation						
Diameter symbol						
M6	4 to 6 {0.4 to 0.6}	-	8 to 12 {0.8 to 1.2}	-	9 to 14 {0.9 to 1.4}	-
M8	10 to 15 {1.0 to 1.5}	-	19 to 28 {1.9 to 2.8}	-	22 to 32 {2.2 to 3.3}	-
M10	21 to 30 {2.1 to 3.1}	20 to 28 {1.9 to 2.9}	39 to 58 {3.9 to 6.0}	37 to 53 {3.6 to 5.4}	50 to 65 {5.0 to 6.5}	45 to 65 {4.5 to 6.5}
M12	38 to 54 {3.8 to 5.5}	35 to 51 {3.4 to 5.2}	80 to 110 {8.0 to 11}	70 to 95 {7.0 to 9.5}	90 to 120 {9.0 to 12}	85 to 110 {8.5 to 11}

Hex-head Nut

Unit: N·m (kgf·m)

Strength classification	4T		6T	
Representation			   	
Diameter symbol	Standard screw	Coarse screw	Standard screw	Coarse screw
M5	2 to 3 {0.2 to 0.3}	-	4 to 6 {0.4 to 0.6}	-
M6	4 to 6 {0.4 to 0.6}	-	7 to 11 {0.7 to 1.1}	-
M8	9 to 14 {0.9 to 1.4}	-	17 to 26 {1.7 to 2.6}	-
M10	19 to 28 {1.9 to 2.8}	18 to 26 {1.8 to 2.7}	36 to 52 {3.5 to 5.5}	33 to 49 {3.3 to 5.0}
M12	35 to 50 {3.4 to 5.0}	31 to 46 {3.1 to 4.7}	70 to 95 {7.0 to 9.5}	65 to 85 {6.5 to 8.5}
M14	60 to 85 {6.0 to 8.5}	55 to 75 {5.5 to 7.5}	120 to 160 {12 to 16}	110 to 140 {11 to 14}
M16	90 to 130 {9.5 to 13}	90 to 120 {9.0 to 12}	180 to 240 {18 to 24}	160 to 220 {16 to 22}
M18	140 to 190 {14 to 19}	120 to 160 {12 to 16}	260 to 340 {25 to 35}	220 to 290 {22 to 30}
M20	190 to 260 {19 to 26}	170 to 230 {17 to 23}	350 to 470 {36 to 48}	320 to 420 {32 to 43}
M22	260 to 340 {26 to 35}	230 to 300 {23 to 31}	470 to 640 {48 to 65}	430 to 570 {43 to 58}
M24	340 to 450 {34 to 46}	290 to 390 {29 to 40}	630 to 840 {63 to 86}	540 to 730 {55 to 74}

Hex-head Flange Nut

Unit: N·m (kgf·m)

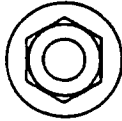
Strength classification	4T	
Representation		
Diameter symbol	Standard screw	Coarse screw
M6	4 to 6 {0.4 to 0.6}	-
M8	10 to 15 {1.0 to 1.5}	-
M10	21 to 30 {2.1 to 3.1}	20 to 28 {1.9 to 2.9}
M12	38 to 54 {3.8 to 5.5}	35 to 51 {3.4 to 5.2}

<https://www.ebooklibonline.com>

Hello dear friend!

Thank you very much for reading.

Enter the link into your browser.

The full manual is available for immediate download.

<https://www.ebooklibonline.com>