

**KOBELCO**

**SERVICE MANUAL**

**mitsubishi DIESEL ENGINE**  
**6D2**

**Applicable Engine Models:**

**6D22**

**6D22-T**

**6D22-TC**

Applicable Engine No. 6D22-144531~

# 6D2

## ENGINE

# Shop Manual

### FOREWORD

This shop manual contains the specification, construction, operation, adjustment and service procedures of the Model 6D22, 6D22-T, 6D22-TC diesel engine for service mechanics engaged in servicing of the Mitsubishi diesel engines.

Please make the most of this shop manual to perform correct servicing and wasteless operations.

Note that some of the contents of this shop manual are subject to change owing to improvements, etc. that may be introduced after publication of this shop manual.

SEP. 1987

Applicable Engine Models

6D22	}	For industrial use
6D22-T		
6D22-TC		

Applicable Engine No.

6D22-144531 ~

### GROUP INDEX

<b>GENERAL</b> .....	<b>00</b>
<b>ENGINE</b> .....	<b>11</b>
<b>LUBRICATION</b> .....	<b>12</b>
<b>FUEL AND ENGINE CONTROL</b> .....	<b>13</b>
<b>COOLING</b> .....	<b>14</b>
<b>INTAKE AND EXHAUST</b> .....	<b>15</b>
<b>ENGINE ELECTRICAL</b> .....	<b>16</b>
<b>CLUTCH</b> .....	<b>21</b>
<b>SPECIAL EQUIPMENT</b> .....	<b>61</b>

## ORGANIZATION – GROUP CLASSIFICATION

### 1. GROUP CLASSIFICATION

This manual is organized into several groups classified according to the engine basic elements.

No.	Group name	Description
00	General	External view, major specifications, engine outputs classified by application, engine numbers, caution plate, general bolts and nuts tightening torque table
11	Engine	Engine proper (cylinder head, valve mechanism, camshaft, piston, crankshaft, timing gear, flywheel), specifications, service standards, special tool, troubleshooting
12	Lubrication	Lubrication system (oil pump, oil filter, oil cooler), specifications, service standards, troubleshooting
13	Fuel and engine control	Fuel system (injection pump, injection nozzle, fuel filter), specifications, service standards, special tool, troubleshooting
14	Cooling	Cooling system (water pump, thermostat, radiator, cooling system cleaning procedures, fan), specifications, service standards, special tool, troubleshooting
15	Intake and exhaust	Air cleaner, turbocharger, intake air cooler specifications, service standards, troubleshooting
16	Engine electrical	Starter, alternator, preheating system, relays, automatic stop device, specifications, service standards, special tool, troubleshooting
21	Clutch	Clutch proper, bearing case, specifications, service standards, special tool, troubleshooting
61	Special equipment	Air compressor specification, service standards, special tool

**NOTE:**

**Each group starts with page 1.**

**<https://www.ebooklibonline.com>**

Hello dear friend!

Thank you very much for reading.

Enter the link into your browser.

The full manual is available for immediate download.

**<https://www.ebooklibonline.com>**

### 2. GENERAL PRECAUTIONS FOR SERVICING

Before starting the service procedures, check the vehicle for total time driven, use conditions, and user's complaints and requests to know exactly the engine conditions. Record information where necessary.

To ensure you are doing correct and efficient service jobs, observe the following precautions:

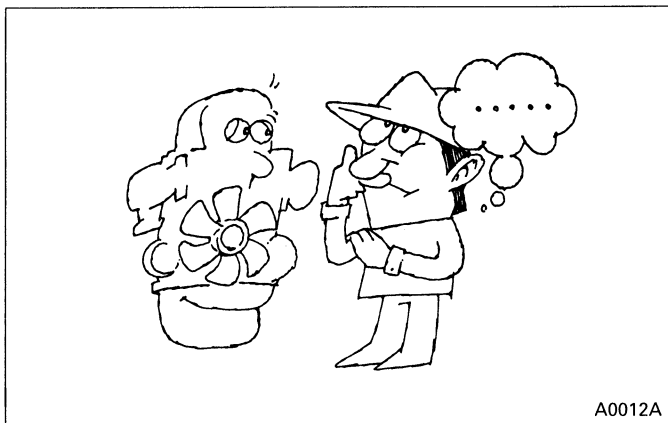

(1) Before performing the service procedures given in this manual, know the trouble spots and isolate the possible cause to determine whether the removal or disassembly procedure is required.

(2) Select a flat surface for the service job.

(3) When servicing the electrical system, be sure to disconnect the negative cable from the battery.

(4) Carefully check parts for oil leaks before cleaning. After cleaning, it may become difficult to spot defective areas.

(5) Ready and make the most of the special tools required for servicing. Use the right tools (specified special tools) in the right place to prevent damages to parts and personal injury.

(6) Make alignment marks and keep disassembled parts neatly arranged to ensure that they are reassembled into the right positions.

- Special care must be taken for assemblies involving a number of parts, similar parts, or parts identical at right- and left-hand sides to ensure correct reassembly.
- For alignment and punching markings, select a position that would not mar the appearance and function.
- Clearly distinguish parts to be replaced from those reused.

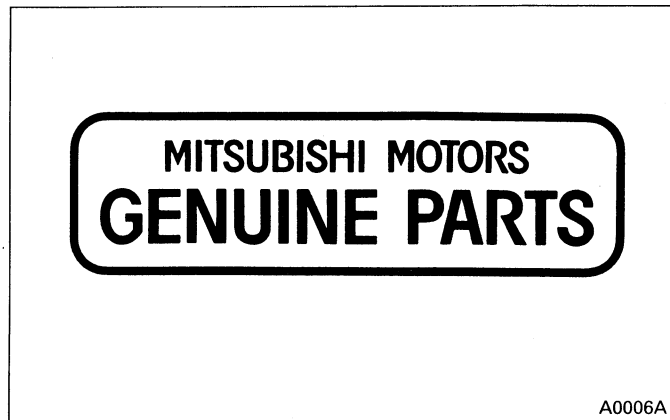

(7) The oil seals, packings, O-rings, and other rubber parts, gaskets, and split pins must be replaced with a new one whenever they are removed. For replacement, use Mitsubishi Genuine parts.

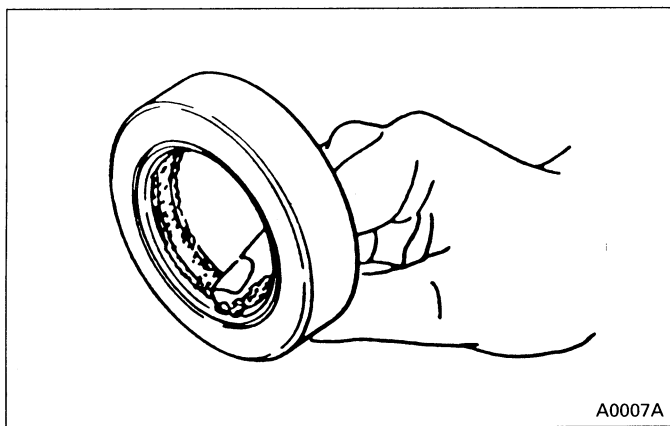

(8) Apply the specified grease to U-packings, oil seals, dust seals, and bearings before installation.

(9) When work requires an assistant or two, always make sure of the safety each other. Never play with switches and levers.

(10) Make sure that your shoes are free from grease and oil especially when working on a heavy item.

(11) When checking or changing lubricants, wipe off grease and oil from parts immediately with a waste.

(12) Special care must be taken in handling sensors and relays which are susceptible to shocks and heat.

(13) Use care so that hands and fingers are not injured by sharp edges or corners of the parts.

(14) Wear safety goggles whenever handling a grinder or welding machine. Wear gloves as required to ensure utmost safety.

# ORGANIZATION – TERMS AND UNITS, TABLE OF CONVERSION RATE FOR FOOT-POUND UNITS INTO SI UNITS

## 3. TERMS AND UNITS

The following terms and units are used throughout the entire texts of this manual.

### (1) Front and Rear

The terms "front" is the fan side and "rear" the flywheel side of the engine.

### (2) Right and Left

The terms "right" and "left" shall be used to indicate the side as viewed from the flywheel side of the engine.

### (3) Service Standard Terms

- Nominal value

Shows the nominal dimensions, dimension of an individual part, standard clearance between parts in an assembly, or the standard performance of an assembly.

- Limit

Shows the value of a part at which the part is no longer serviceable from the performance as well as strength viewpoints, requiring replacement or repair.

### (4) Tightening Torque

Over- or undertightening of bolts and nuts has critical effects on performance and functions.

Tightening torque is therefore specified for some tightening points.

All tightening torque specifications may be considered as "dry" unless "wet" is specified.

Where no tightening torque is specified, use a torque value specified in the General Bolts and Nuts Tightening Torque Table.

### (5) Units

For length, weight, area, and volume, the SI unit (International System of Units) is used with the metric notation jointly shown in parentheses.

Temperature is shown in centigrade (°C).

## 4. TABLE OF CONVERSION RATE FOR FOOT-POUND UNITS INTO SI UNITS

Unit	Sign of SI unit	Sign of foot-pound unit	Conversion rate
Mass quantity of matter	kg g	lb oz	1 kg = 2.2046 lb 1 g = 0.035274 oz
Dimension	m mm	ft. in.	1 m = 3.2808 ft. 1 mm = 0.03937 in.
Capacity	lit. cc	gal. oz	1 lit. = 0.2642 gal. (U.S.) 1 lit. = 0.220 gal. (Imp.) 1 cc = 0.033814 oz (U.S.) 1 cc = 0.035195 oz (Imp.)
Force	N (Newton)	lbf	1 N = 0.2248 lbf
Pressure	kPa (kilopascal)	lbf/in. <sup>2</sup>	1 kPa = 0.145 lbf/in. <sup>2</sup> 1 kPa = 0.2953 in.Hg
Stress	N/cm <sup>2</sup>	lbf/in. <sup>2</sup>	1 N/cm <sup>2</sup> = 1.45 lbf/in. <sup>2</sup>
Moment of force	N m	ft. lbf	1 N m = 0.7375 ft. lbf
Output	kW (kilowatt)	HP	1 kW = 1.34 HP
Temperature	°C	°F	t°C = (1.8t°C + 32)°F

# ORGANIZATION – READING THE ILLUSTRATION

## 5. READING THE ILLUSTRATION

(Ex. 1: Disassembly and Inspection)

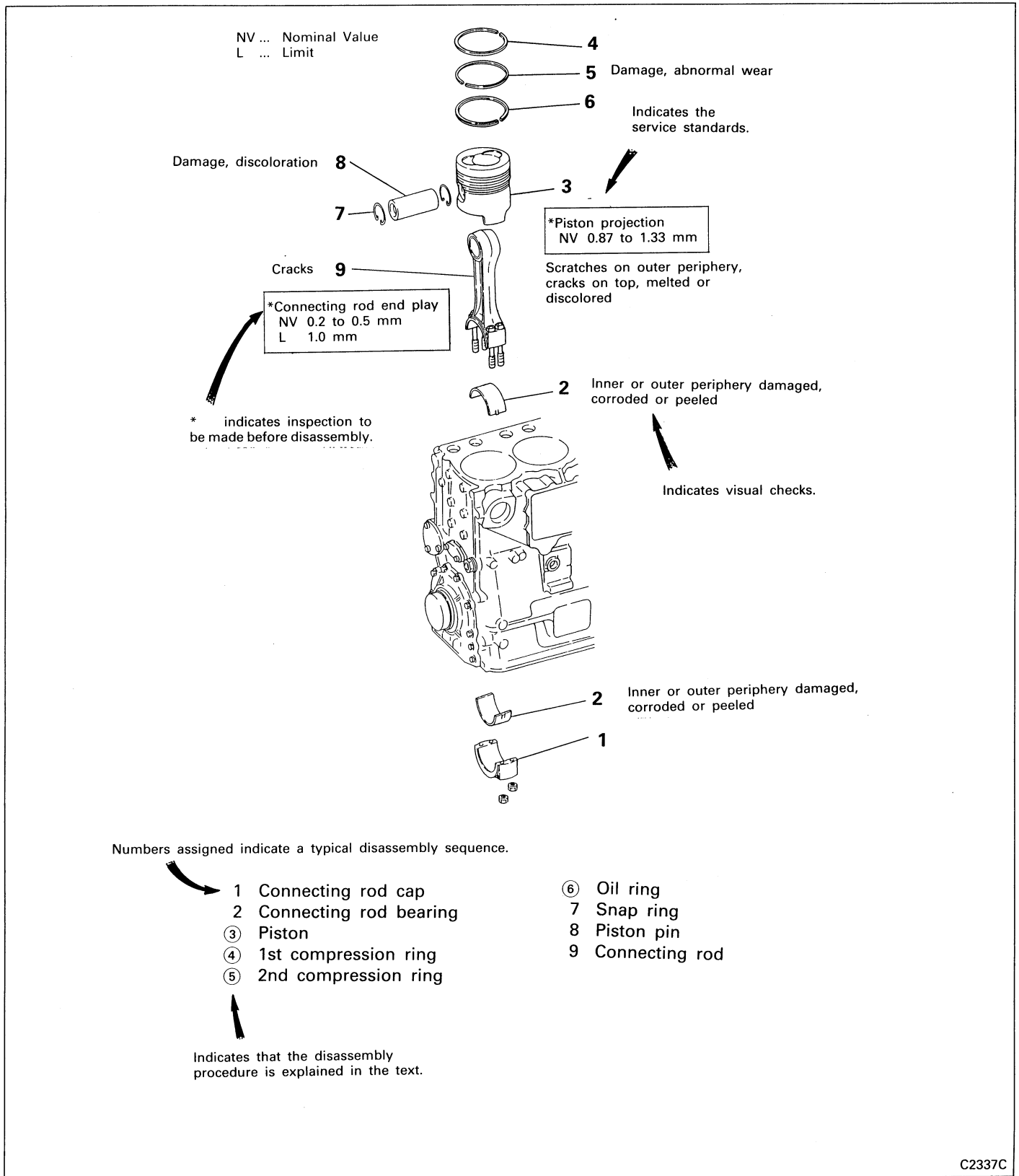

C2337C

# ORGANIZATION – READING THE ILLUSTRATION

(Ex. 2: Reassembly)

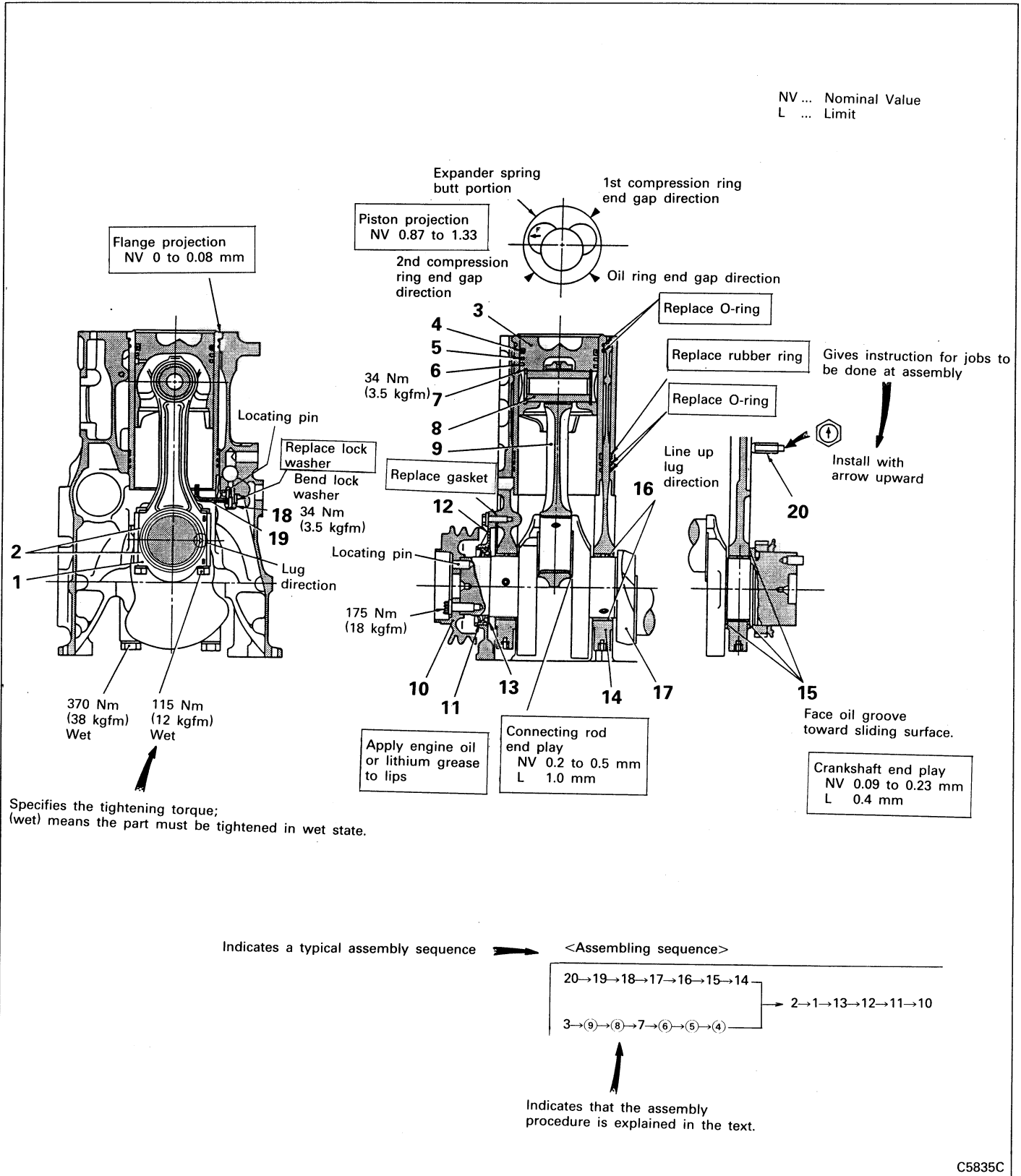

(1) Illustrations (exploded views and assembly drawings) show a typical service procedures if it is

identical among various types of available systems and units.

---

# GENERAL

## CONTENTS

<b>1. EXTERNAL VIES .....</b>	<b>2</b>	<b>3. ENGINE NUMBERS AND</b>	
<b>1.1 EXTERNAL VIEW</b>		<b>CAUTION PLATE .....</b>	<b>6</b>
<b>PHOTOGRAPHS .....</b>	<b>2</b>	<b>4. GENERAL BOLTS AND NUTS</b>	
<b>2. MAJOR SPECIFICATIONS .....</b>	<b>5</b>	<b>TIGHTENING TORQUE TABLE .....</b>	<b>7</b>
<b>2.1 MAJOR SPECIFICATIONS .....</b>	<b>5</b>		
<b>2.2 ENGINE OUTPUTS CLASSIFIED</b>			
<b>BY APPLICATION .....</b>	<b>5</b>		

**1. EXTERNAL VIEW****1.1 EXTERNAL VIEW PHOTOGRAPHS**

6D22 Model

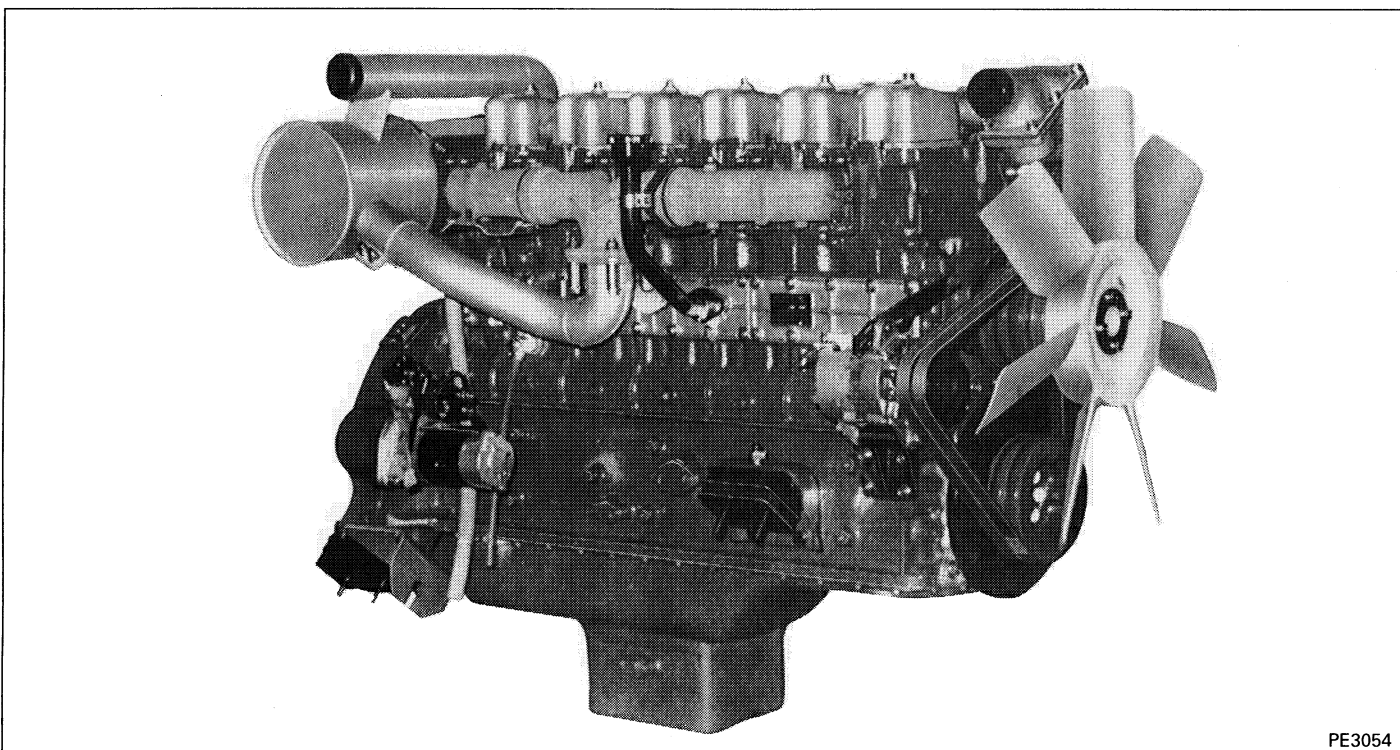
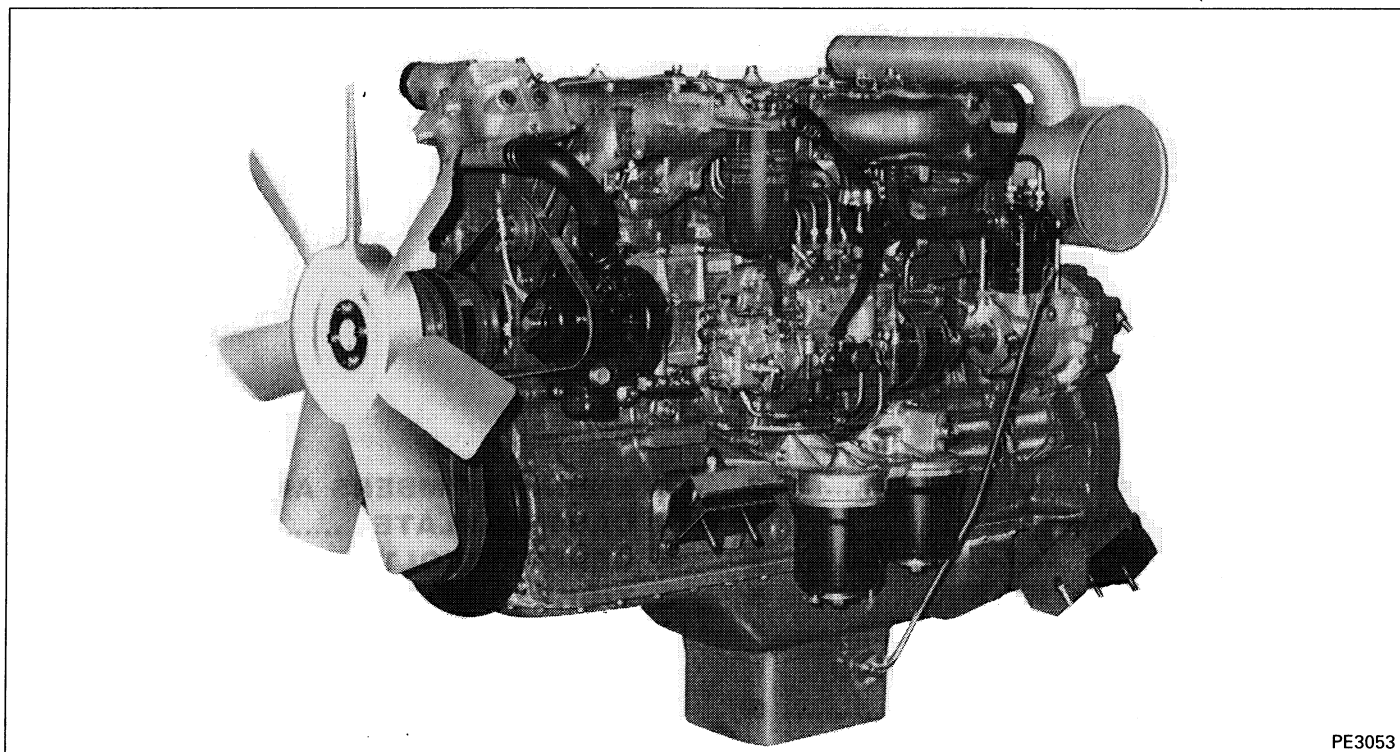

6D22-T Model

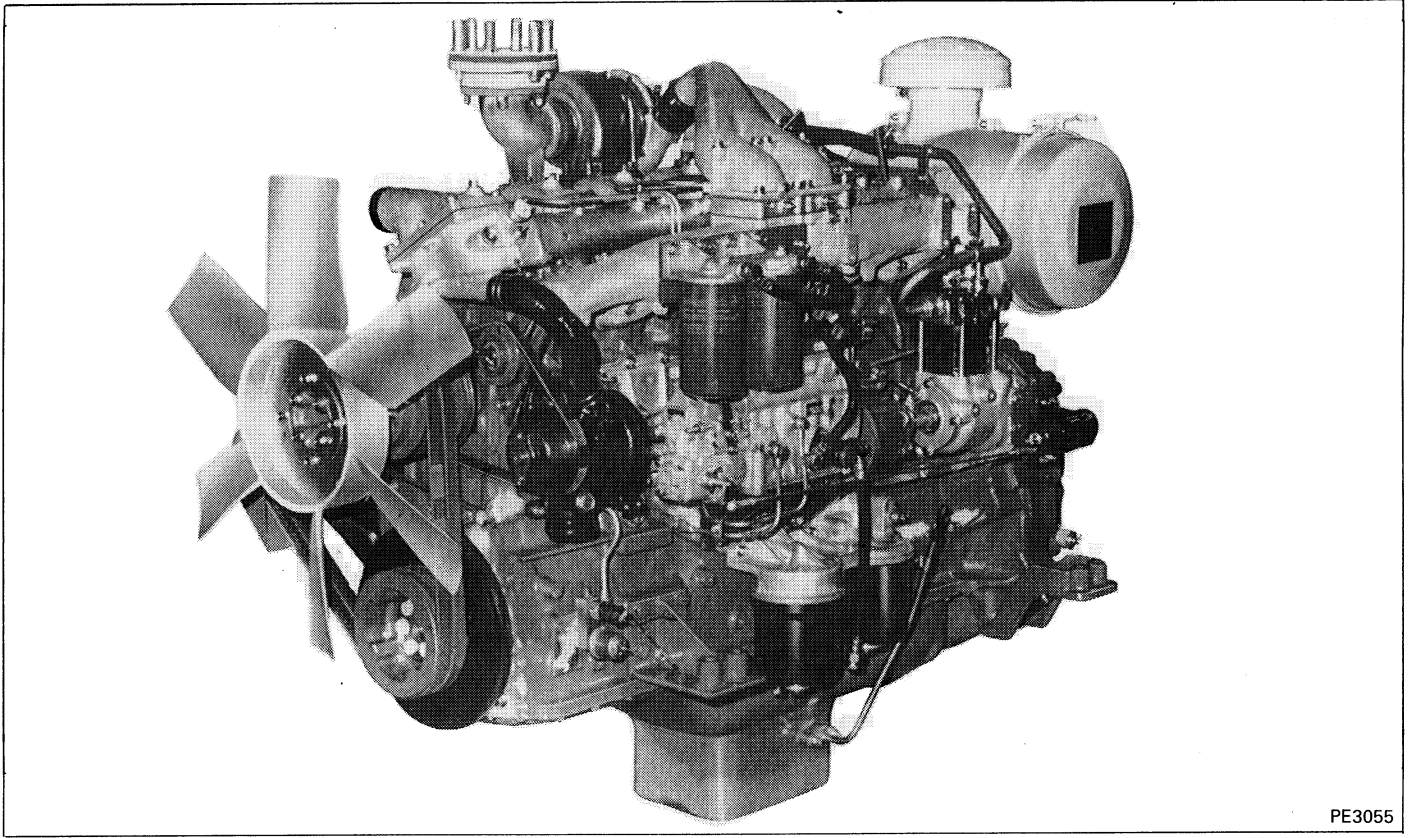

PE3055

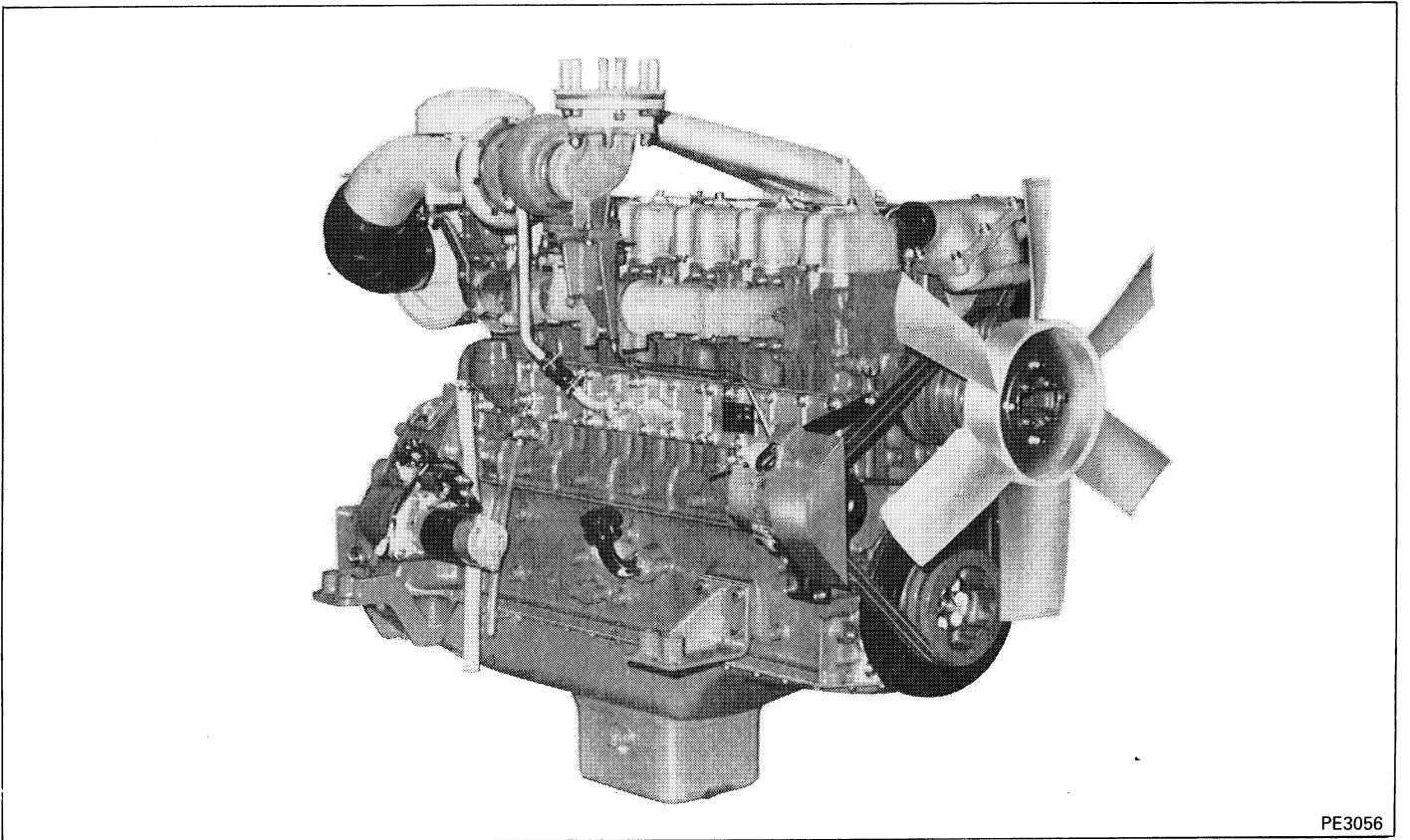

PE3056

6D22-TC Model

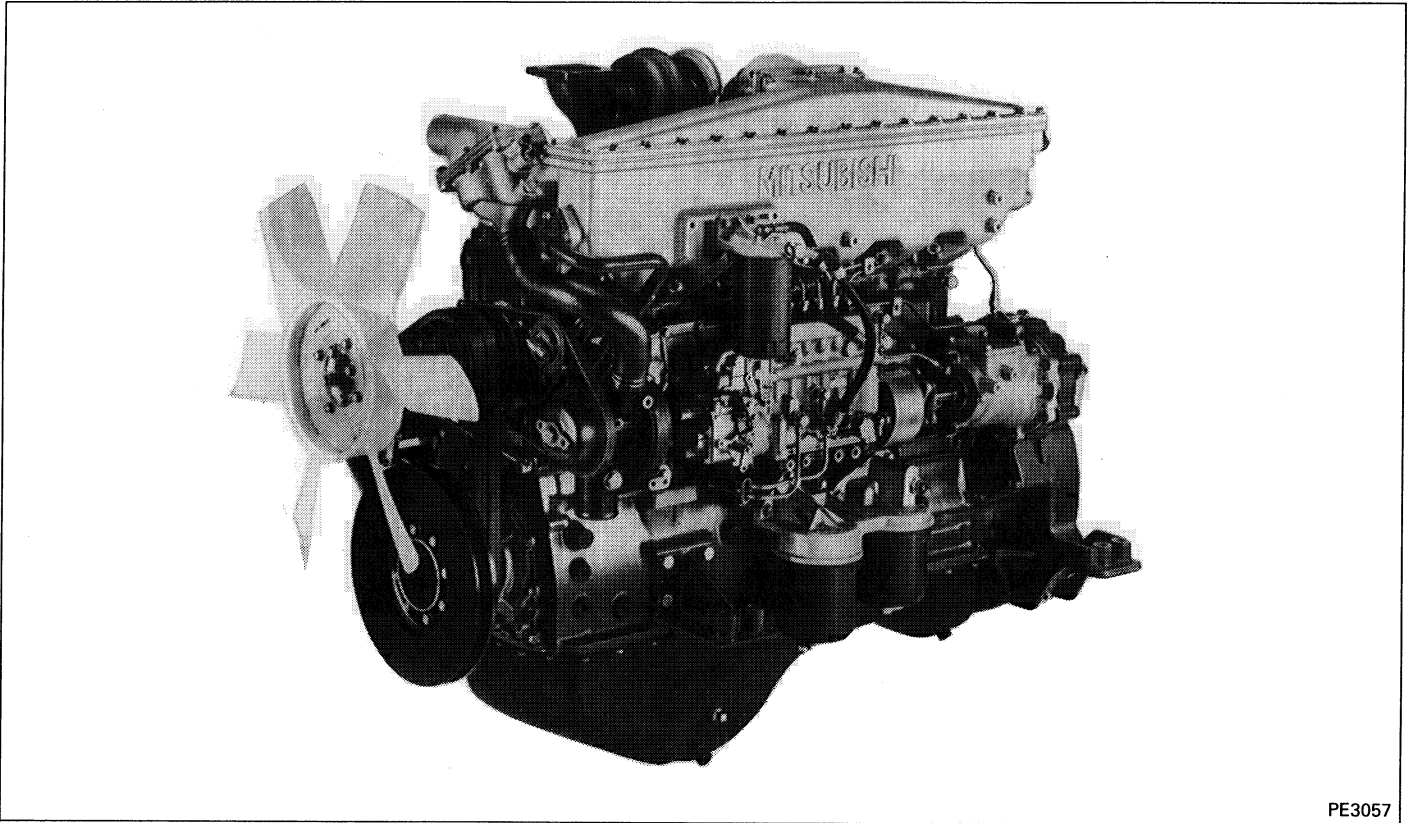

PE3057

**2. MAJOR SPECIFICATIONS**

**2.1 MAJOR SPECIFICATIONS**

Item	Specifications		
	6D22	6D22-T (Turbocharged)	6D22-TC (Turbocharged, with after cooler)
Model			
Combustion method	Direct injection	Direct injection	Direct injection
No. and arrangement of cylinder	6 in-line	6 in-line	6 in-line
Cylinder bore x stroke	mm 130 x 140	130 x 140	130 x 140
Total displacement	cc 11 149	11 149	11 149
Empty weight	kg* 930	970	990

\* Empty weight as measured according to Mitsubishi Motors Corporation standard.

**2.2 ENGINE OUTPUTS CLASSIFIED BY APPLICATION**

Application	Engine model	6D22	6D22-T (Turbocharged)	6D22-TC (Turbocharged with after cooler)
		Intermittent rated output	kW (HP)/rpm	112 (150)/1 500 132 (177)/1 800 144 (193)/2 000 152 (204)/2 200
Continuous rated output	kW (HP)/rpm	102 (137)/1 500 120 (161)/1 800 131 (175)/2 000 138 (185)/2 200	143 (192)/1 500 163 (219)/1 800 171 (230)/2 000 177 (237)/2 200	167 (224)/1 500 194 (259)/1 800 204 (273)/2 000 211 (283)/2 200

**NOTE:**

- 1. The output (SAE, gross) is corrected to standard ambient conditions based on SAE J1349.**
- 2. The continuous rated output allows 10% (one hour) overload operation.**

### 3. ENGINE NUMBERS AND CAUTION PLATE

#### (1) Engine Number

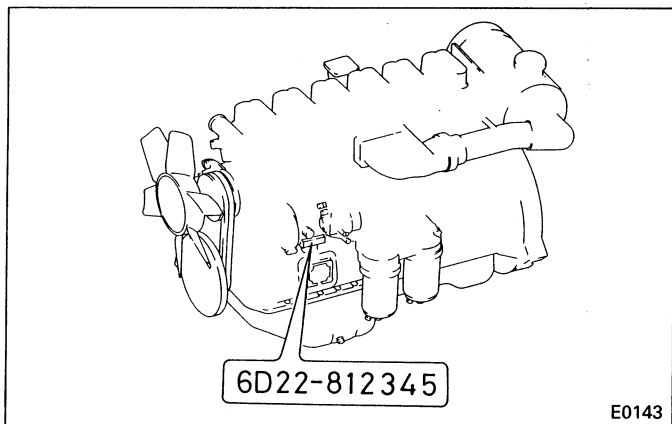

The engine number is stamped on the position as illustrated.

Ex: 6 D 2·2 - 8 1 2 3 4 5

Engine number

Engine model

The engine number is important in knowing the history of the engine.

#### (2) Caution Plate

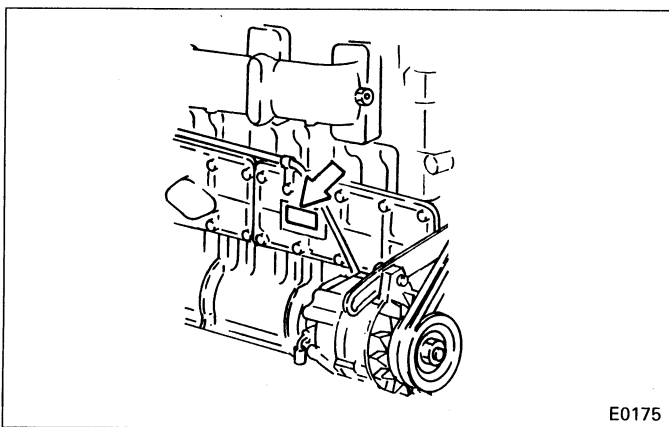

The caution plate is located as illustrated. The caution plate bears the valve clearance, fuel injection sequence and timing.

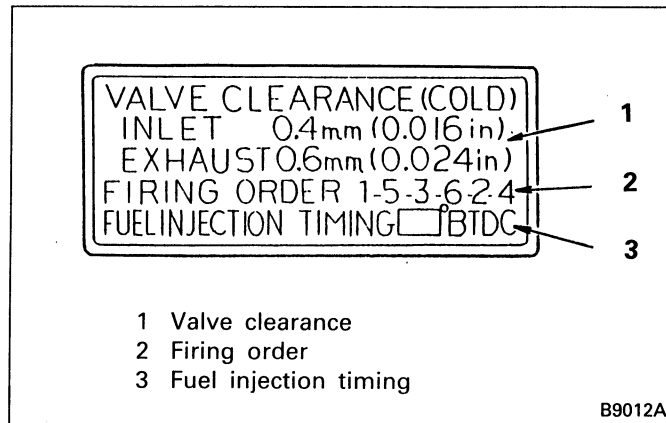

# GENERAL – GENERAL BOLTS AND NUTS TIGHTENING TORQUE TABLE

## 4. GENERAL BOLTS AND NUTS TIGHTENING TORQUE TABLE

Unless otherwise specified, the parts and equipment of vehicle must be tightened by the following standard bolts and nuts. Tightening torques for these bolts and nuts are shown below.

**NOTE:**

**Threads and seat surfaces must be in dry state.**

Standard bolts and nuts

Unit: Nm (kgfm)

Dia. mm	Pitch mm	4T (Head mark 4 or ○)	7T (Head mark 7 or ⊙)	8T (Head mark 8 or ⊕)
5	0.8	2.0 to 2.9 (0.2 to 0.3)	3.9 to 5.9 (0.4 to 0.6)	4.9 to 6.9 (0.5 to 0.7)
6	1.0	3.9 to 5.9 (0.4 to 0.6)	6.9 to 10.8 (0.7 to 1.1)	7.8 to 11.8 (0.8 to 1.2)
8	1.25	8.8 to 13.7 (0.9 to 1.4)	16.7 to 25.5 (1.7 to 2.6)	19.6 to 29.4 (2.0 to 3.0)
10	1.25	18.6 to 27.5 (1.9 to 2.8)	34.3 to 53.9 (3.5 to 5.5)	44.1 to 58.8 (4.5 to 6.0)
	1.5	17.7 to 26.5 (1.8 to 2.7)	32.4 to 49.0 (3.3 to 5.0)	42.1 to 58.8 (4.3 to 6.0)
12	1.25	33.3 to 49.0 (3.4 to 5.0)	68.6 to 93.2 (7.0 to 9.5)	83.4 to 108 (8.5 to 11)
	1.75	30.4 to 46.1 (3.1 to 4.7)	63.7 to 83.4 (6.5 to 8.5)	73.5 to 98.1 (7.5 to 10)
14	1.5	58.8 to 83.4 (6.0 to 8.5)	118 to 157 (12 to 16)	127 to 177 (13 to 18)
	2.0	53.9 to 73.5 (5.5 to 7.5)	108 to 137 (11 to 14)	118 to 167 (12 to 17)
16	1.5	93.2 to 127 (9.5 to 13)	177 to 235 (18 to 24)	196 to 265 (20 to 27)
	2.0	88.3 to 118 (9.0 to 12)	157 to 216 (16 to 22)	186 to 255 (19 to 26)

Flange bolts and nuts

Unit: Nm (kgfm)

Dia. mm	Pitch mm	4T (Head mark 4 or ○)	7T (Head mark 7 or ⊙)	8T (Head mark 8 or ⊕)
6	1.0	3.9 to 5.9 (0.4 to 0.6)	7.8 to 11.8 (0.8 to 1.2)	8.8 to 13.7 (0.9 to 1.4)
8	1.25	9.8 to 14.7 (1.0 to 1.5)	18.6 to 27.5 (1.9 to 2.8)	21.6 to 32.4 (2.2 to 3.3)
10	1.25	20.6 to 30.4 (2.1 to 3.1)	38.2 to 58.8 (3.9 to 6.0)	49.0 to 63.7 (5.0 to 6.5)
12	1.25	37.3 to 53.9 (3.8 to 5.5)	78.5 to 108 (8.0 to 11)	88.3 to 118 (9.0 to 12)

---

# ENGINE

## CONTENTS

<b>1. GENERAL .....</b>	<b>2</b>	<b>5.1.2 Cylinder Head and Valve Mechanism .....</b>	<b>18</b>
<b>1.1 ENGINE PROPER .....</b>	<b>2</b>	<b>5.1.3 Flywheel, Timing Gear and Camshaft .....</b>	<b>29</b>
<b>2. SPECIFICATIONS .....</b>	<b>8</b>	<b>5.1.4 Crankcase and Main Moving Parts .....</b>	<b>40</b>
<b>3. SERVICE STANDARDS .....</b>	<b>9</b>	<b>5.1.5 Inspection and Adjustment of Valve Clearance .....</b>	<b>59</b>
<b>3.1 SERVICE STANDARD TABLE .....</b>	<b>9</b>	<b>6. TROUBLESHOOTING .....</b>	<b>61</b>
<b>3.2 TIGHTENING TORQUE TABLE ...</b>	<b>12</b>		
<b>4. SPECIAL TOOL .....</b>	<b>13</b>		
<b>5. SERVICE PROCEDURES .....</b>	<b>17</b>		
<b>5.1 ENGINE PROPER .....</b>	<b>17</b>		
<b>5.1.1 Measurement of Compression Pressure .....</b>	<b>17</b>		

## 1. GENERAL

### 1.1 ENGINE PROPER

#### (1) Combustion Chamber

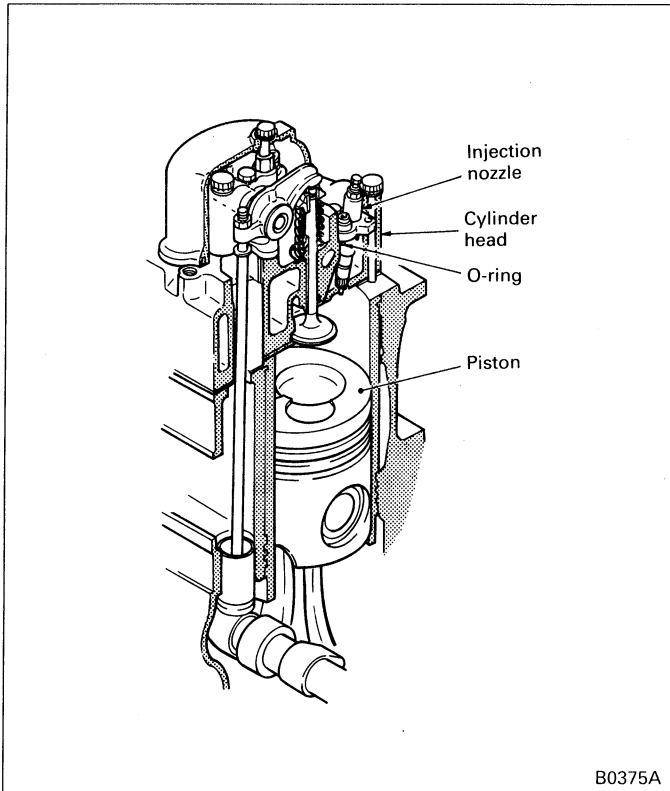

The combustion chamber is made up of the cylinder head and piston top. The injection nozzle as well as the nozzle tube is mounted to the cylinder head. The nozzle tube holds the nozzle in position and protects the nozzle sheathed by it from coolant. Since the outside of the nozzle tube is exposed to the water jacket, the top end of the tube is sealed off with an O-ring and the bottom end staked to prevent entrance of water.

Combustion is accomplished by compressing the fuel directly injected into the combustion chamber.

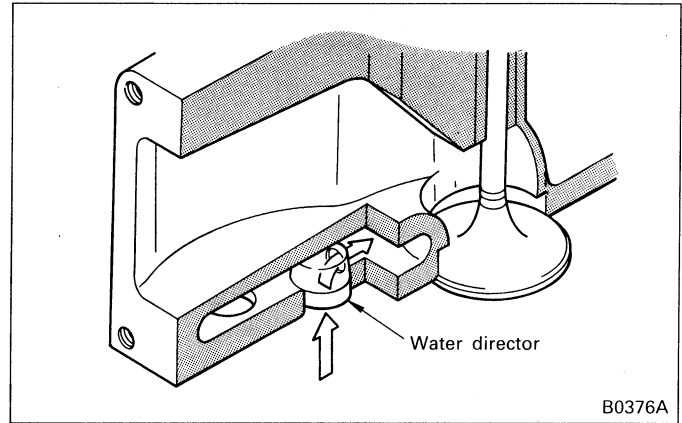

For more effective cooling of the combustion chamber, water directors which direct coolant flow are pressed into the bottom of the cylinder head.

#### (2) Valve Mechanism

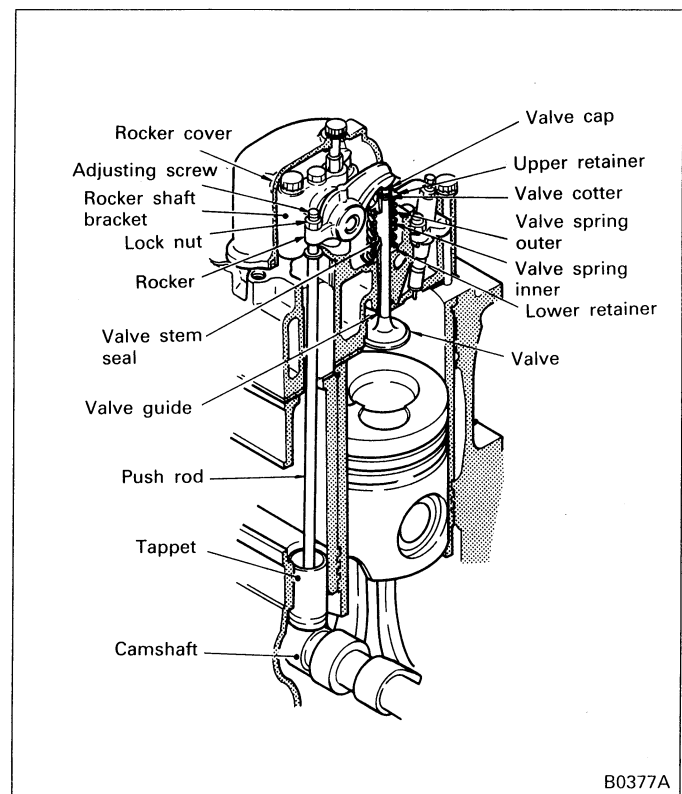

The valve mechanism is of overhead valve type and is constructed as shown above.

(a) Both inlet and exhaust valves are made of surface-treated heat-resistant steel. The valve seat angle is  $45^\circ$ .

A valve stem seal is provided on the stem of valve to control the quantity of lubricant of the valve and valve guide sliding portions.

(b) The valve springs are unevenly-pitched springs. Two inner and outer springs different in coiled direction are installed.

(c) The rocker and rocker shaft are supported on the rocker shaft bracket and are independently installed for each cylinder. Some rockers are used for both inlet and exhaust valves, and the end sliding portion is quenched.

The rocker shaft is a hollow round rod sealed off by thrust plates at both ends. The inside of the shaft constitutes an engine oil passage.

(d) A steel ball and concave piece are respectively welded to the bottom and top ends of the push rod and both ends are case-hardened.

(e) The tappet is of cylindrical shape and its mating surfaces with the camshaft are spherical. The tappet is removable through the side of the crankcase.

(f) The cam profile of the camshaft has a special curve. The surface is induction-hardened to improve the performance of the valve mechanism at high speed operation and improve wear resistance.

### (3) Crankcase and Cylinder Liner

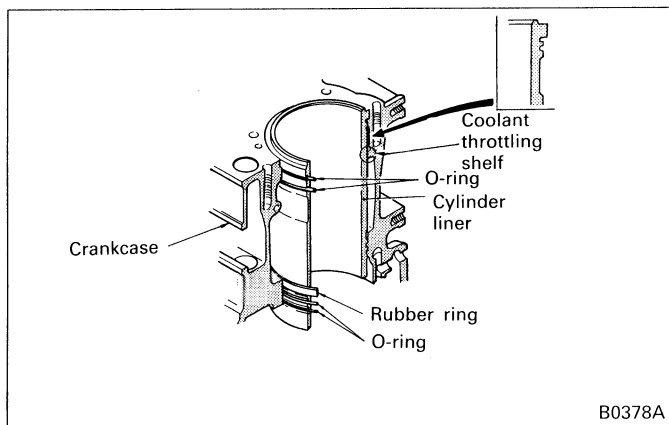

(a) The crankcase is made of cast iron and is of high-rigidity construction free from stress concentration and deformation.

(b) Seven camshaft bushings are installed to the camshaft bearing portion of the crankcase. To facilitate insertion and removal of the camshaft from the rear end of the case, the bearing I.D. is narrower toward the front.

(c) The coolant fed in from the water pump at the left front end of the crankcase cools the oil cooler, then flows through the water jacket holes and around all the cylinders to cool them before reaching the cylinder head.

(d) The cylinder liner is of removable wet type and its top and bottom are press-fitted at the top of the crankcase and the water jacket in crankcase, respectively.

Rubber rings and O-rings are installed at the top and bottom of cylinder liner to prevent entry of coolant. The water jacket has a coolant throttling shelf for higher cooling performance.

### (4) Piston and Piston Ring

#### (a) Piston

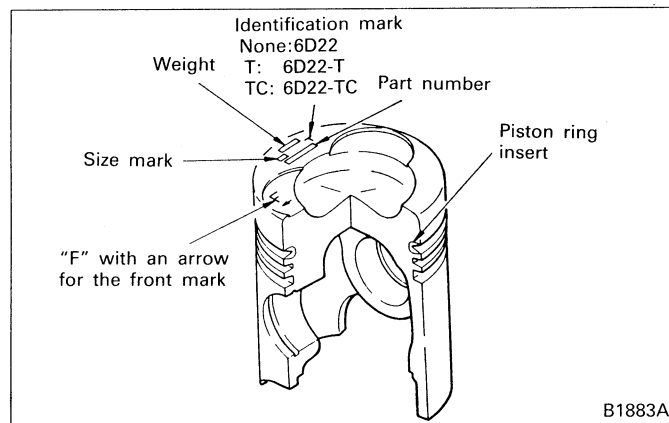

The piston, made of aluminum alloy casting, has a toroidal type combustion chamber at its top.

A Niresist piston ring insert is cast into the 1st piston ring groove to increase durability.

Stamped on the top surface of the piston are a size mark (or oversize dimension on oversize pistons) for selection fit with the cylinder liner, a piston weight mark, part number, and the "F" with an arrow for the front mark showing the piston installing direction. Piston pin for connecting piston to connecting rod is of full-floating type and is prevented from moving out by means of a snap ring installed on each end of the pin ends.

### (b) Piston ring

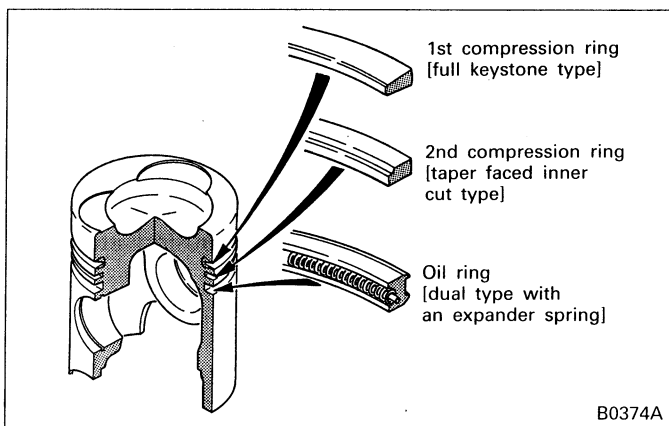

There are three piston rings installed: two compression rings and one oil ring. The sliding surface of each ring is hard chrome plated to improve durability. The piston rings are shaped as shown in the figure.

### (5) Connecting Rod and Connecting Rod Bearing

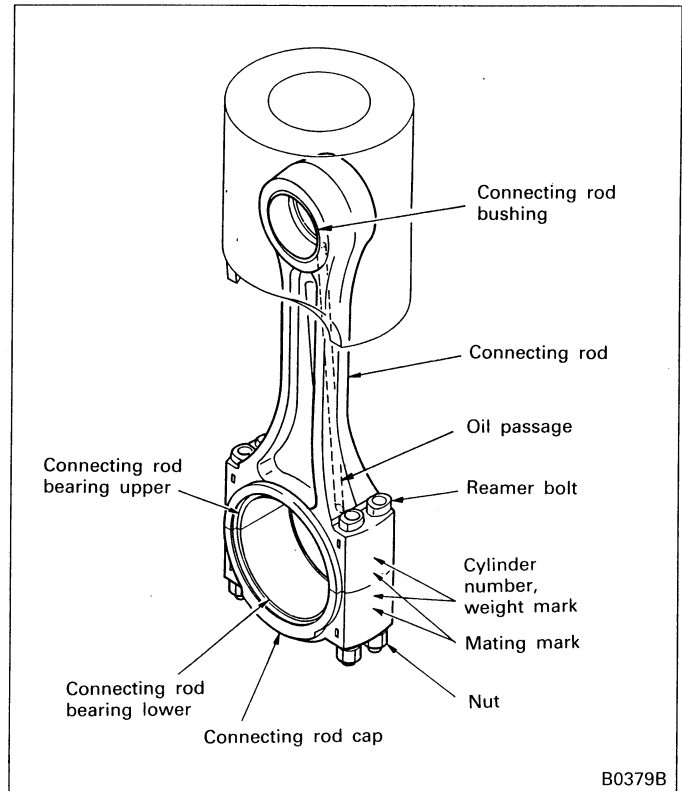

The connecting rod is a die forging of I cross section providing high rigidity. A lead bronze bushing is press-fitted onto the small end. The connecting rod bearing of the big end is a split type plain bearing. Through the stem of connecting rod, an oil passage is provided obliquely to lubricate the small end bushing. The connecting rod and connecting rod cap are coupled with four bolts.

### (6) Crankshaft and Main Bearing

#### (a) Crankshaft

The crankshaft is a high-rigidity die forging integral with the balance weight.

The pins and journals are induction-hardened for higher wear resistance. An oil hole in each journal is through to that in pin, feeding some of the main bearing lubricating oil to the pin for lubrication of the connecting rod bearing.



**Suggest:**

**For more complete manuals. Please go to the home page.**

**<https://www.ebooklibonline.com>**

**If the above button click is invalid. Please download this document first, and then click the above link to download the complete manual.**

**Thank you so much for reading**

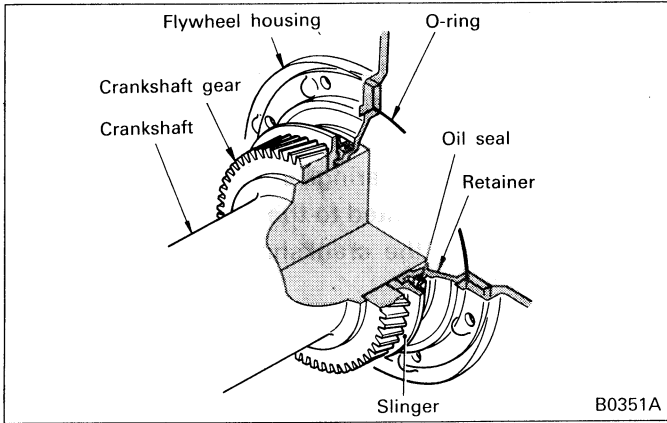

The crankshaft gear driving timing gear is fitted onto the rear end of the crankshaft.  
 Note that the crankshaft has an axial lip type oil seal fitted to each of its front and rear ends.

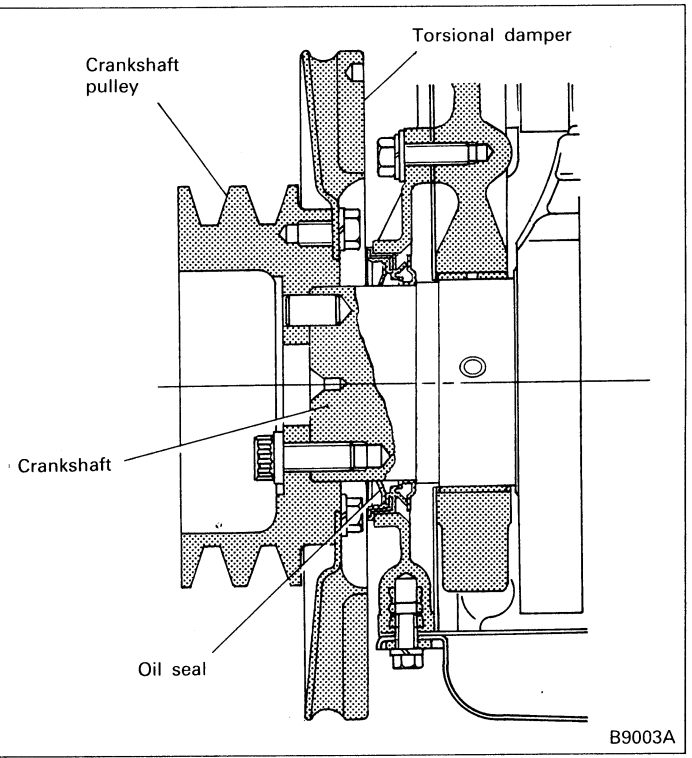
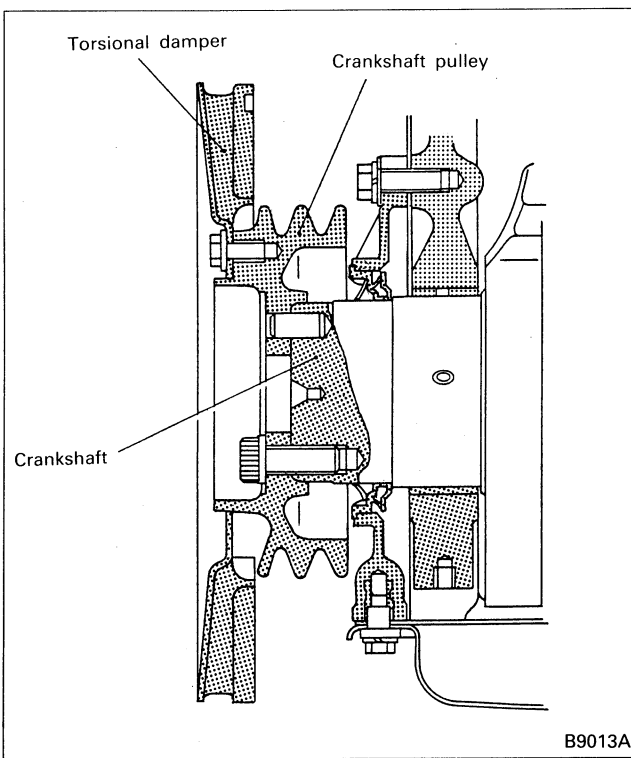

The front portion of the crankshaft is a flange type to which the crankshaft pulley is mounted with bolts. A torsional damper mounted to the pulley absorbs the torsional vibration of the crankshaft.

**(b) Main bearing**

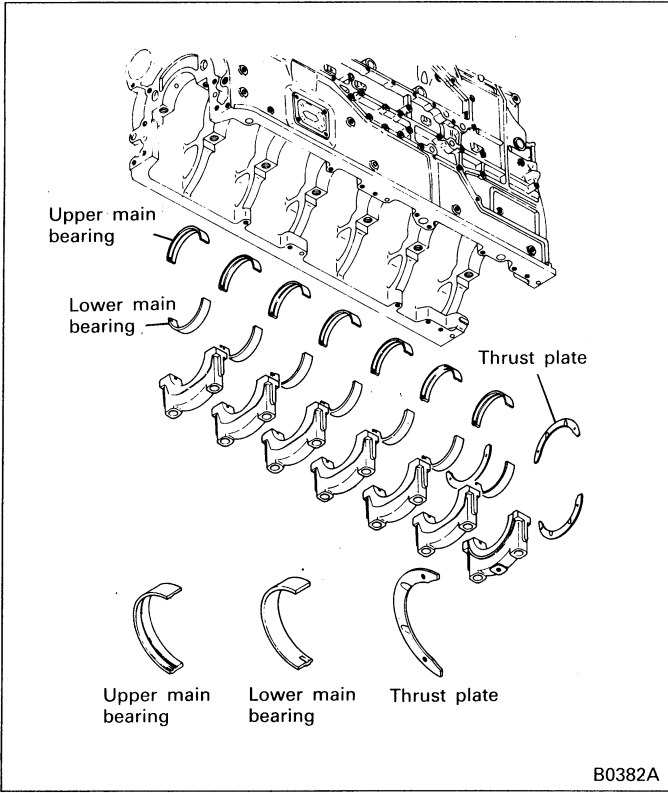

The main bearing is a split type plain bearing made of special alloy plated kelmet metal with backing metal. The upper main bearing has an internal oil groove and oil hole which coincides with the oil hole in the crankshaft.

Seven pairs of main bearings are provided. Split type thrust plates are mounted to the rear-most bearing to bear the thrust of the crankshaft.

**(7) Timing Gears**

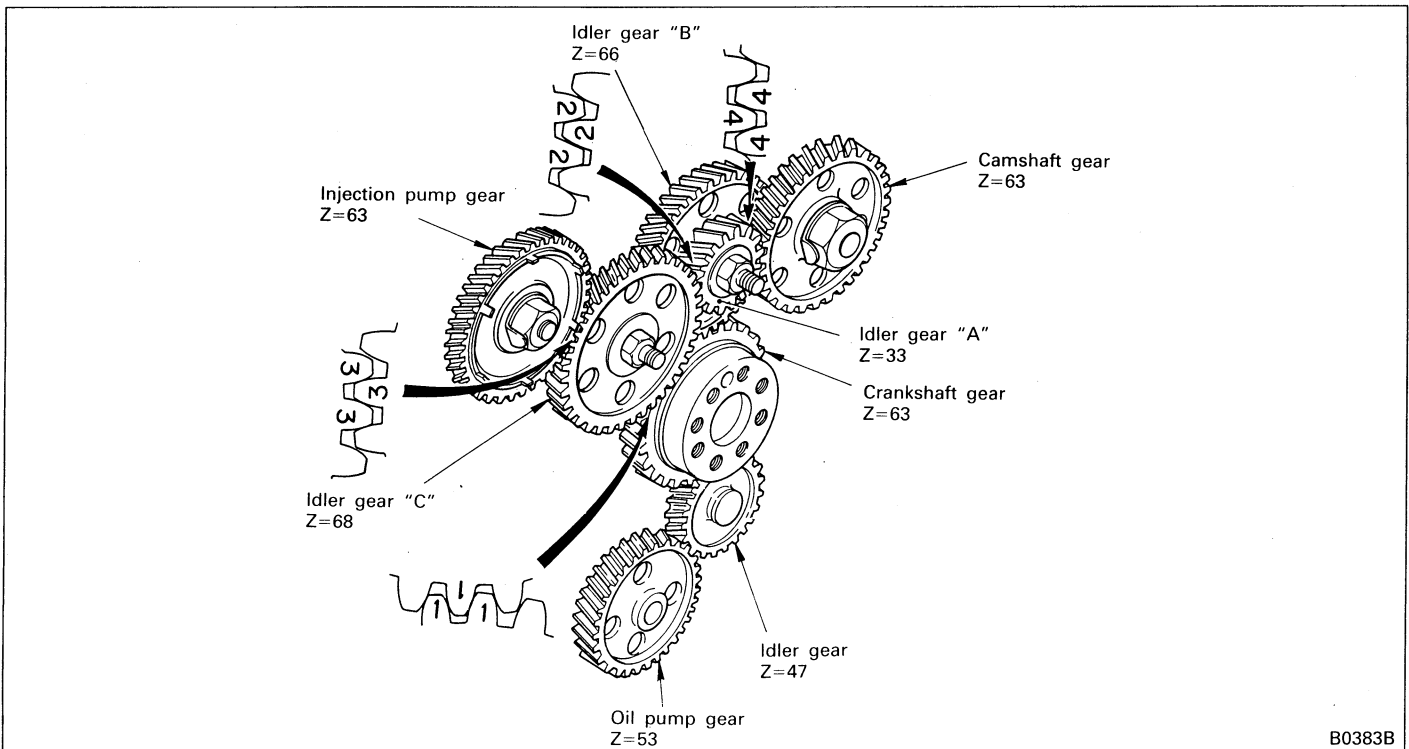

The timing gears are accommodated in the flywheel housing at the rear of the engine. The gear train is as

shown above.

**<https://www.ebooklibonline.com>**

Hello dear friend!

Thank you very much for reading.

Enter the link into your browser.

The full manual is available for immediate download.

**<https://www.ebooklibonline.com>**