

6D1

diesel engine
Shop Manual
(for Industrial use)
FOREWARD

This Shop Manual is published for the information and guidance of personnel responsible for maintenance of Mitsubishi 6D1 series diesel engine, and includes procedures for adjustment and maintenance services.

We earnestly look forward to seeing that this manual is made useful in order to perform proper service.

For more details, please consult your nearest authorized Mitsubishi dealer or distributor. Kindly note that the specifications and maintenance service figures are subject to change without prior notice in line with improvement which will be effected from time to time in the future.

Applicable models

6D16-TLE1 --- ASIA, OCEANIA
6D16-TLUA --- EU
6D16-TLEB --- KAI

GROUP INDEX

HOW TO READ THIS MANUAL

GENERAL	00
ENGINE	11
LUBRICATION	12
FUEL AND ENGINE	13
COOLING	14
INTAKE AND EXHAUST	15
ELECTRICAL SYSTEM	54

GROUP 00 GENERAL

GENERAL SPECIFICATIONS	2
ENGINE NUMBER AND NAME PLATE	3
PRECAUTIONS FOR MAINTENANCE OPERATION	4
TABLE OF STANDARD TIGHTENING TORQUES	12

GENERAL SPECIFICATIONS

Item	Specifications					
Engine model	6D14	6D14-T	6D15-T	6D16	6D16-T	6D16-TL
Type	6-cylinder in-line, water-cooled 4-cycle diesel					
Combustion chamber type	Direct injection type					
Valve mechanism	Overhead valve (OHV) type					
Bore × Stroke mm	110 × 115		113 × 115	118 × 115		
Total displacement cc	6557		6919	7545		
Compression ratio	17.5	16		17.5	16	17.5
Empty mass kg*	500	540		500	550	580

* Empty mass as measured according to Mitsubishi Motors Corporation standard.

<https://www.ebooklibonline.com>

Hello dear friend!

Thank you very much for reading.

Enter the link into your browser.

The full manual is available for immediate download.

<https://www.ebooklibonline.com>

ENGINE NUMBER AND NAME PLATE

The serial number for engine is assigned to the respective engine in manufacturing sequence: every engine has its own number. This number is required for incidental inspection of the engine. Please do not fail to mention this number to the dealers when ordering spare parts.

Engine Number

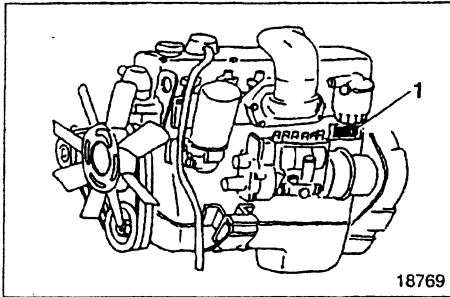

Engine number 1 is punch-marked on the left of the crankcase.

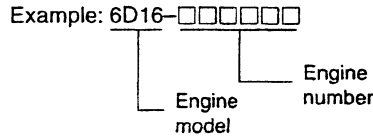

Name Plate

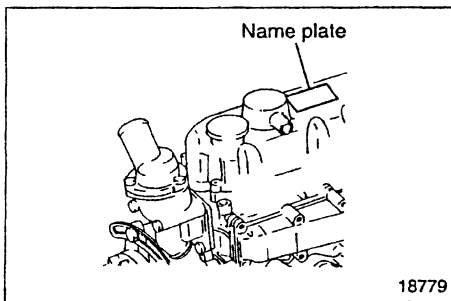

The name plate is attached to the portion shown in the illustration, and indicate the following items.

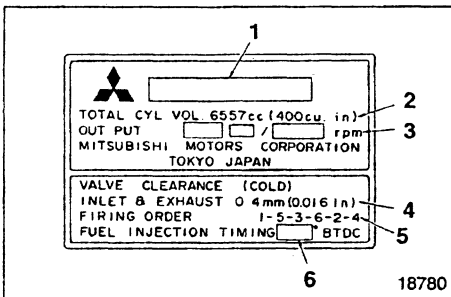

- 1 Engine model
- 2 Total displacement
- 3 Maximum output
- 4 Valve clearance
- 5 Firing order
- 6 Fuel injection timing

PRECAUTIONS FOR MAINTENANCE OPERATION

In order to determine the condition of the vehicle adequately, attend the vehicle beforehand to find and keep record of the accumulated mileage, operating condition, what the customer's demand is, and other information that may be necessary. Prepare the steps to be taken and perform efficient and wasteless maintenance procedure.

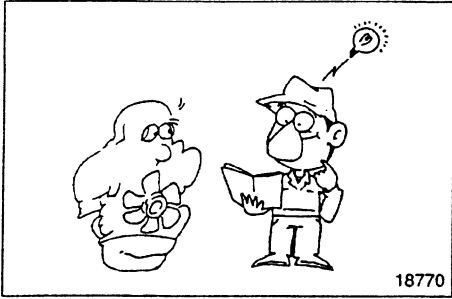

Determine where the fault exists and check for the cause to see whether removal or disassembly of the part is necessary. Then follow the procedure specified by this manual.

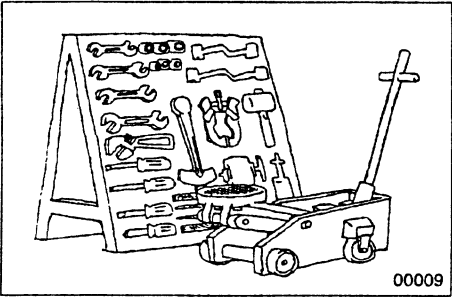

Perform maintenance work at a level area.

Prepare the following.

- Prepare general and special tools necessary for the maintenance work.

WARNING

Do not attempt to use tools other than special tools where use of special tools is specified in this manual. This will avoid injury or damage.

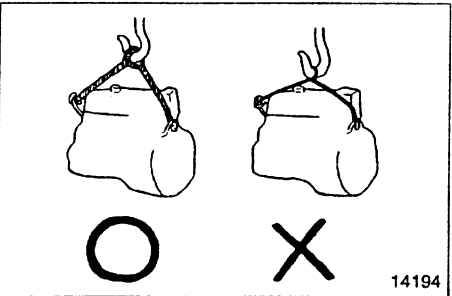

Pay special attention to safety when removing or installing heavy items such as engines, transmissions.

When lifting up heavy items using cables, pay special attention to the following points:

- Check the mass of the item to be lifted and use a cable capable of lifting that mass.

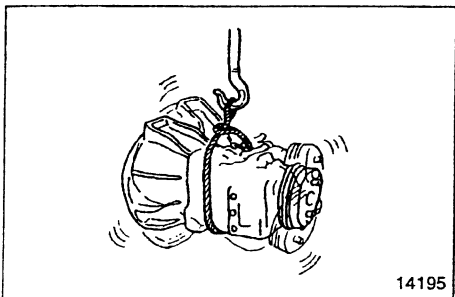

- If you do not have the specified lifting hanger, secure the item using cable taking the point-of-balance of the item into consideration.

- You must work in a position where you will not be injured even if the cable comes undone and the lifted item falls.

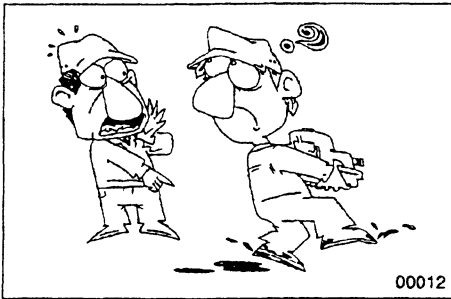

00012

Be particularly careful not to work in shoes that have oily soles and are slippery. When working as a team of two or more, arrange signals in advance and keep confirming safety. Be careful not to accidentally bump switches or levers.

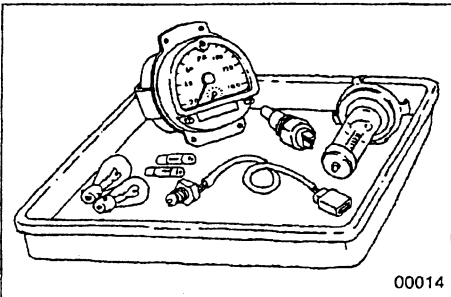

00014

Check for oil leakage before cleaning the area having the fault otherwise you might miss detecting the leakage. Prepare replacement part(s) beforehand.

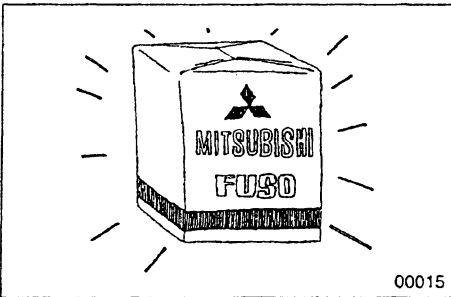

00015

Replace oil seals, packing, O-rings and other rubber parts; gaskets and split pins with new parts whenever any of them has been removed. Use only genuine MITSUBISHI replacement parts.

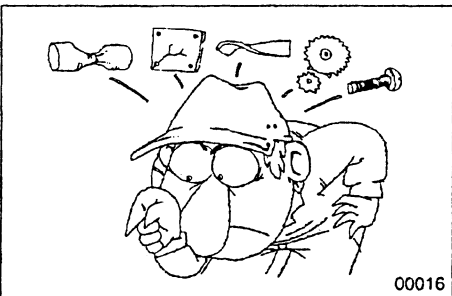

00016

On disassembly, visually inspect all parts for wear and tear, cracks, damage, deformation, degradation, rust, corrosion, smoothness in rotation, fatigue, clogging and any other possible defect.

PRECAUTIONS FOR MAINTENANCE OPERATION

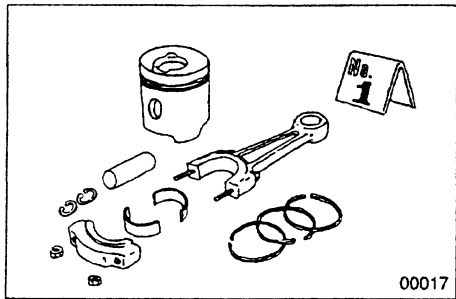

Put alignment marks on part combinations before disassembly and arrange the disassembled parts neatly. This will help avoid mismatching of the parts later.

Put the alignment marks, punch marks, etc. where performance and appearance will not be affected.

Cover the area left open after removal of parts to keep it free from dust.

CAUTION

- Take care to avoid mixing up numerous parts, similar parts, left and right, etc.
- Keep new parts for replacement and original (removed) parts separate.

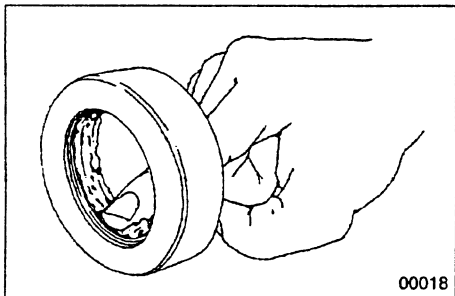

Apply the specified oil or grease to U-packings, oil seals, dust seals and bearings during assembly.

Use only the specified oil, grease, etc. for lubricant, remove the excess immediately after application with a piece of waste, etc.

CAUTION

When the specified lubricant, fluid and sealant is not available, you may use an equivalent.

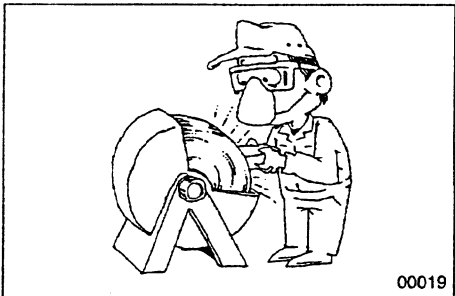

Wear goggles when using a grinder or welder. Pay full attention to safety by wearing gloves when necessary. Watch out for sharp edges, etc. that might injure your hands or fingers.

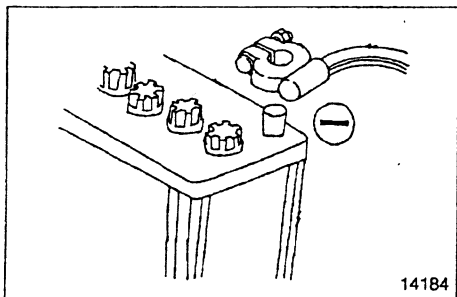

Before carrying out maintenance work on the electric system, disconnect the negative terminals of the batteries to prevent them from short-circuiting and burning-out.

CAUTION

Be sure to turn starter and lighting switches, etc. off before disconnecting or connecting battery terminals, because the semi-conductors can be damaged.

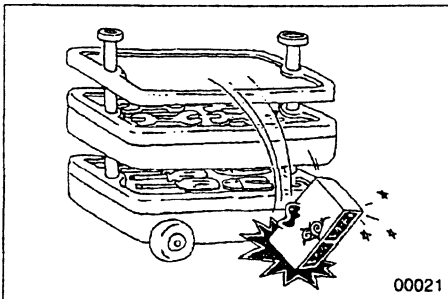

Take care when handling sensors, relays, etc. which are vulnerable to shock and heat. Do not attempt to remove the cover from, or apply paint to, the electronic control unit.

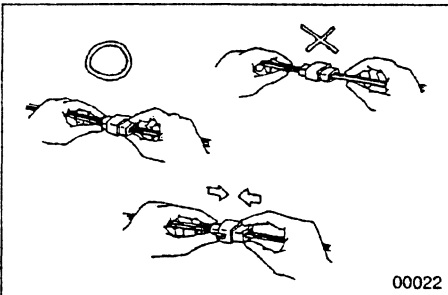

Pull the connector, and not the harness lead, to separate connectors. To separate a lock-type connector, first push toward arrow mark. To reconnect a lock-type connector, press the separated parts until they click together.

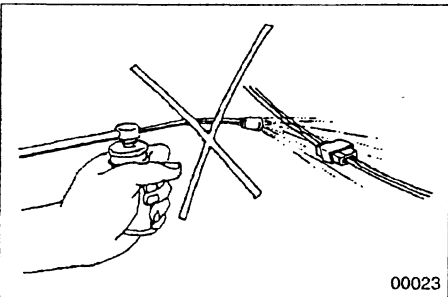

When washing the vehicle, cover the electric system parts and instruments with waterproof material beforehand (Cover with vinyl sheet or the like). Keep water away from harness wire connectors and sensors. If any of them should get wet, wipe them off immediately.

When using an electric welder, such electronic parts that are directly connected to the batteries might be damaged due to the flow of current from the welder that flows through the negative circuit. Parts that have switches might be subject to the same danger if the switches are left on.

Therefore, do not fail to observe the following.

- Connect the negative terminal of the welder as near as possible to the area that is to be welded.
- Disconnect the negative terminals of batteries.

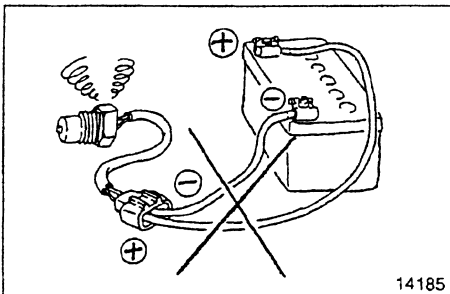

To apply voltage for testing, check that the positive and negative cables are connected properly, then increase voltage gradually from 0 volt. Do not apply voltage higher than the specified value. In particular, pay close attention to the electronic control unit and sensors, since they are not always fed the battery voltage.

PRECAUTIONS FOR MAINTENANCE OPERATION

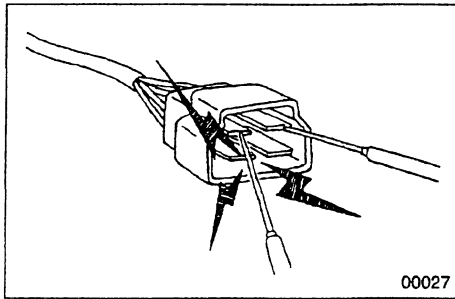

When using testers or the like for continuity tests, be careful not to allow test probes to touch the wrong terminals.

Measurement Procedures Using Connectors

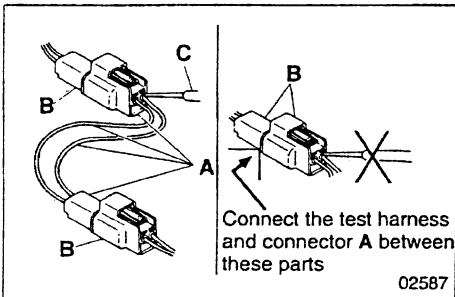

Test with connectors engaged (continuity through circuit obtained) <Waterproof connector>

Prepare a test harness and connectors A, then connect it between the two parts of harness B that is to be tested. Check the circuit by touching test probe C to the test connector.

Never insert the test probe from the harness side of the waterproof connection, or waterproof performance might be diminished causing corrosion of the connector.

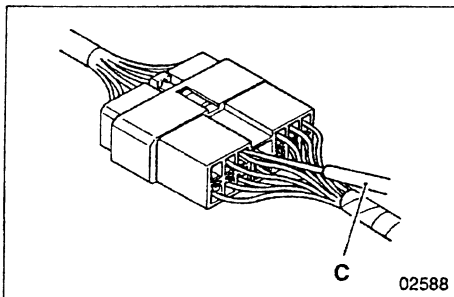

<Non-waterproof connector>

Insert test probe C from the harness side of the connector. Where control units, etc. have connectors that are too small to accept the test probe, do not force the test probe into them.

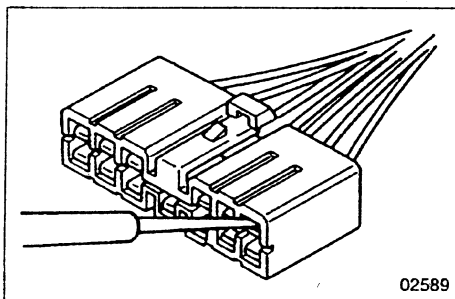

Test with connectors disengaged

Using female pins

Insert a test probe into a terminal. However, do not force the probe into the terminal, or it will cause a poor contact.

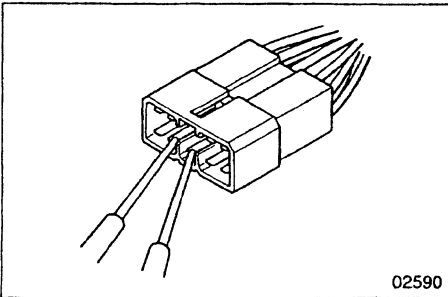

Using male pins
Touch the pins directly using test probes.

CAUTION ⚠

Be sure that you do not short circuit the connector pins when you use the test probe because this could damage the internal circuit of the electronic control unit.

Connector Inspection Procedures

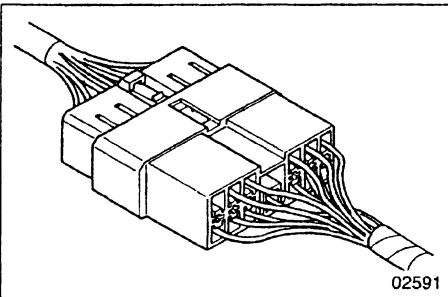

Visual inspection

Check for loose connection and poor engagement.

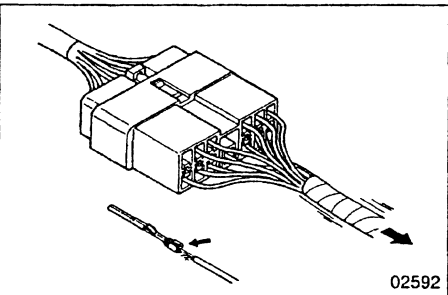

Check if harnesses are broken by pulling gently around the terminals.

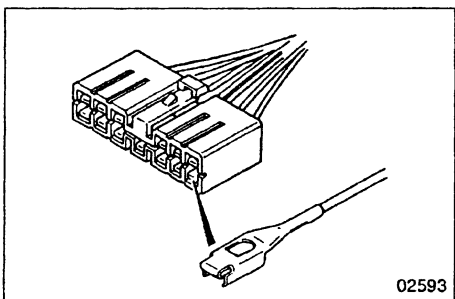

Check for a decrease in contact pressure between the male and female terminals.

Check for poor contact caused by connector pins having fallen out, rusted terminals or foreign particles.

PRECAUTIONS FOR MAINTENANCE OPERATION

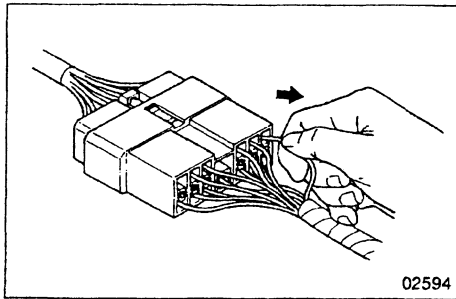

Connector pin fall out inspection

Damaged connector pin stoppers can cause poor engagement of the terminals (male and female pins) even if the connector body is secured, and might cause some pins to fall out. Check if the pins have fallen out from the connector by pulling each harness gently.

Inspection Procedures for Blown Fuses

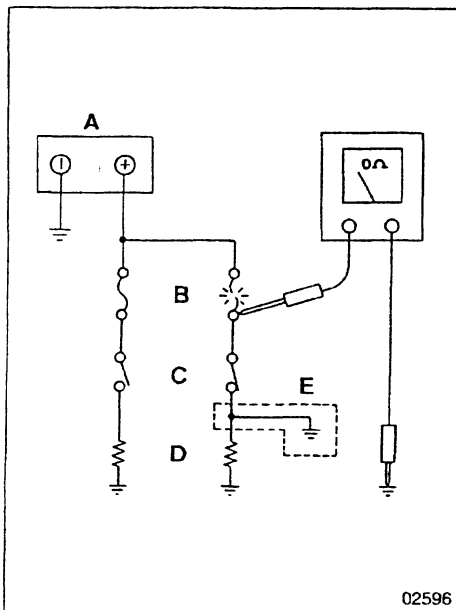

Remove fuse **B** and measure resistance between the loaded side of the fuse and ground.

Turn on all circuit switches (connected to the fuse). If the resistance value reading is approximately 0, a short has occurred between the switch and the loaded point. A value of other than zero may indicate that the fuse was blown by a temporary short but the short is no longer present.

The major causes of a short circuit are as follows:

- Harness stuck onto the vehicle body.
- Harness sheath damaged by friction or heat.
- Water in connectors or circuits.
- Mistakes (accidental short circuits)

- A: Battery
B: Fuse
C: Loaded switch
D: Load
E: Short circuit

Precautions for Handling Alternator

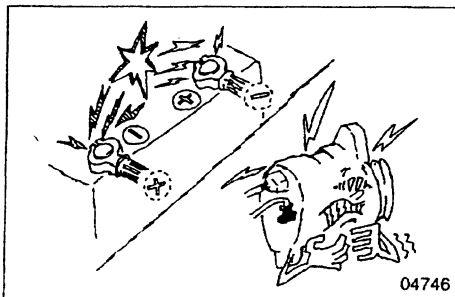

When servicing the alternator, pay attention to the following:

- Do not connect the alternator with battery polarities reversed. If the alternator is connected with reversed polarities, a large current flow from the battery to the alternator occurs, and the diode or regulator might be damaged.

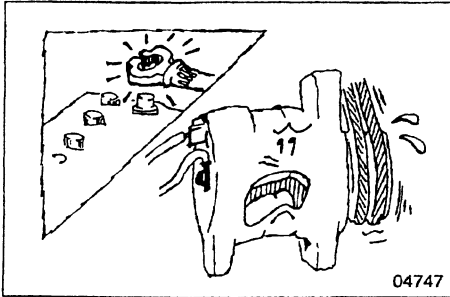

04747

- While the engine is running, do not remove the battery terminals. If the battery terminals are removed at that time, a surge voltage is generated and the diode or regulator might be weakened.

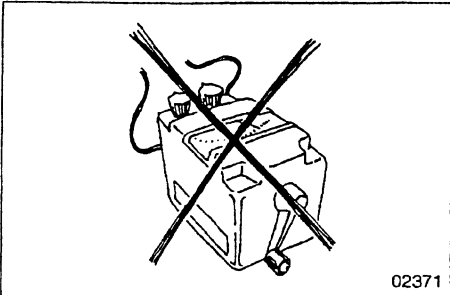

02371

- Do not use a high-voltage tester such as a megger for inspection. If a high-voltage tester is used, the diode or regulator might be destroyed.

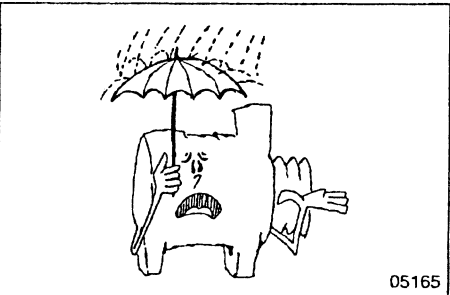

05165

- Do not splash water over the alternator. If water is directly splashed over the alternator, individual components will be short-circuited and might be destroyed.

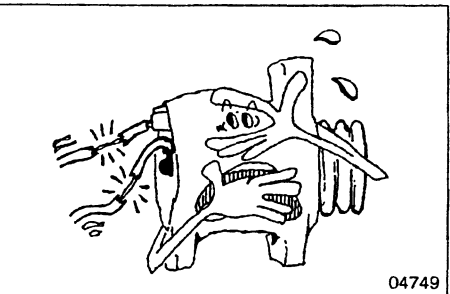

04749

- Do not short-circuit terminal B and terminal L while running the alternator. If the terminals are short-circuited while the alternator is running, the diode trio might be destroyed.

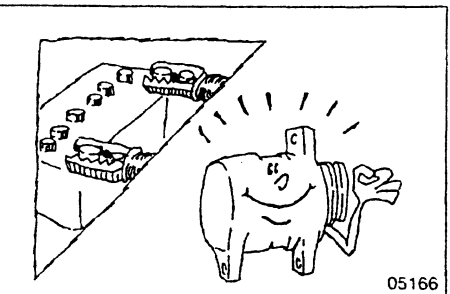

05166







- Disconnect the battery terminals before quick-charging the battery. Quick-charging without disconnecting the battery terminals might damage the diode or regulator.

TABLE OF STANDARD TIGHTENING TORQUES

- Use specified bolts and nuts and tighten them at specified torques according to the following table, unless otherwise specified.
- Threads and contact seats shall be dry.
- Where there is a difference in strength classification between the nut and bolt (or stud bolt), the torque specified for the bolt shall apply.







Hex-head Bolt and Stud Bolt

Unit: N · m (kgf · m)

Strength classification	4T		7T		8T	
Representation						
Diameter symbol	(Stud)		(Stud)		(Stud)	02154
M5	2 to 3 {0.2 to 0.3}	-	4 to 6 {0.4 to 0.6}	-	5 to 7 {0.5 to 0.7}	-
M6	4 to 6 {0.4 to 0.6}	-	7 to 11 {0.7 to 1.1}	-	8 to 12 {0.8 to 1.2}	-
M8	9 to 14 {0.9 to 1.4}	-	17 to 26 {1.7 to 2.6}	-	20 to 29 {2.0 to 3.0}	-
M10	19 to 28 {1.9 to 2.8}	18 to 26 {1.8 to 2.7}	36 to 52 {3.5 to 5.5}	33 to 49 {3.5 to 5.0}	45 to 60 {4.5 to 6.0}	41 to 59 {4.3 to 6.9}
M12	35 to 50 {3.4 to 5.0}	31 to 46 {3.1 to 4.7}	70 to 95 {7.0 to 9.5}	65 to 85 {6.5 to 8.5}	85 to 110 {8.5 to 11}	75 to 100 {7.5 to 10}
M14	60 to 85 {6.0 to 8.5}	55 to 75 {5.5 to 7.5}	120 to 160 {12 to 16}	110 to 140 {11 to 14}	130 to 180 {13 to 18}	120 to 160 {12 to 17}
M16	90 to 130 {9.5 to 13}	90 to 120 {9.0 to 12}	180 to 240 {18 to 24}	160 to 220 {16 to 22}	200 to 270 {20 to 27}	190 to 260 {19 to 26}
M18	140 to 190 {14 to 19}	120 to 160 {12 to 16}	260 to 340 {25 to 35}	220 to 290 {22 to 30}	290 to 390 {30 to 40}	260 to 340 {26 to 35}
M20	190 to 260 {19 to 26}	170 to 230 {17 to 23}	350 to 470 {36 to 48}	320 to 420 {32 to 43}	410 to 550 {41 to 56}	370 to 490 {37 to 50}
M22	260 to 340 {26 to 35}	230 to 300 {23 to 31}	470 to 640 {48 to 65}	430 to 570 {43 to 58}	550 to 740 {56 to 75}	490 to 670 {50 to 68}
M24	340 to 450 {34 to 46}	290 to 390 {29 to 40}	630 to 840 {63 to 86}	540 to 730 {55 to 74}	730 to 980 {74 to 100}	630 to 840 {64 to 86}





Hex-head Flange Bolt

Unit: N · m (kgf · m)

Strength classification	4T		7T		8T	
Representation						
Diameter symbol						02154
M6	4 to 6 {0.4 to 0.6}	-	8 to 12 {0.8 to 1.2}	-	9 to 14 {0.9 to 1.4}	-
M8	10 to 15 {1.0 to 1.5}	-	19 to 28 {1.9 to 2.8}	-	22 to 32 {2.2 to 3.3}	-
M10	21 to 30 {2.1 to 3.1}	20 to 28 {1.9 to 2.9}	39 to 58 {3.9 to 6.0}	37 to 53 {3.6 to 5.4}	50 to 65 {5.0 to 6.5}	45 to 65 {4.5 to 6.5}
M12	38 to 54 {3.8 to 5.5}	35 to 51 {3.4 to 5.2}	80 to 110 {8.0 to 11}	70 to 95 {7.0 to 9.5}	90 to 120 {9.0 to 12}	85 to 110 {8.5 to 11}

Hex-head Nut

Unit: N·m { kgf·m }

Strength classification	4T		6T			
Representation						
Diameter symbol	02155					
	Standard screw	Coarse screw	Standard screw	Coarse screw		
M5	2 to 3 {0.2 to 0.3}	–	4 to 6 {0.4 to 0.6}	–		
M6	4 to 6 {0.4 to 0.6}	–	7 to 11 {0.7 to 1.1}	–		
M8	9 to 14 {0.9 to 1.4}	–	17 to 26 {1.7 to 2.6}	–		
M10	19 to 28 {1.9 to 2.8}	18 to 26 {1.8 to 2.7}	36 to 52 {3.5 to 5.5}	33 to 49 {3.5 to 5.0}		
M12	35 to 50 {3.4 to 5.0}	31 to 46 {3.1 to 4.7}	70 to 95 {7.0 to 9.5}	65 to 85 {6.5 to 8.5}		
M14	60 to 85 {6.0 to 8.5}	55 to 75 {5.5 to 7.5}	120 to 160 {12 to 16}	110 to 140 {11 to 14}		
M16	90 to 130 {9.5 to 13}	90 to 120 {9.0 to 12}	180 to 240 {18 to 24}	160 to 220 {16 to 22}		
M18	140 to 190 {14 to 19}	120 to 160 {12 to 16}	260 to 340 {25 to 35}	220 to 290 {22 to 30}		
M20	190 to 260 {19 to 26}	170 to 230 {17 to 23}	350 to 470 {36 to 48}	320 to 420 {32 to 43}		
M22	260 to 340 {26 to 35}	230 to 300 {23 to 31}	470 to 640 {48 to 65}	430 to 570 {43 to 58}		
M24	340 to 450 {34 to 46}	290 to 390 {29 to 40}	630 to 840 {63 to 86}	540 to 730 {55 to 74}		

Hex-head Flange Nut Unit: N·m { kgf·m }

Strength classification	4T	
Representation		
Diameter symbol	02155	
	Standard screw	Coarse screw
M6	4 to 6 {0.4 to 0.6}	–
M8	10 to 15 {1.0 to 1.5}	–
M10	21 to 30 {2.1 to 3.1}	20 to 28 {1.9 to 2.9}
M12	38 to 54 {3.8 to 5.5}	35 to 51 {3.4 to 5.2}

TABLE OF STANDARD TIGHTENING TORQUES

Tightening torque for flare nut for general purpose

Unit: N · m {kgf · m}

Pipe diameter	φ4.76 mm	φ6.35 mm	φ8 mm	φ10 mm	φ12 mm	φ15 mm
Tightening torque	17 {1.7}	25 {2.6}	39 {4.0}	59 {6.0}	88 {9.0}	98 {10.0}

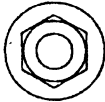
Tightening torque for air piping nylon tube for general purpose {DIN type}

Unit: N · m {kgf · m}

Standard diameter	6 × 1 mm	10 × 1.25 mm	12 × 1.5 mm	15 × 1.5 mm
Tightening torque	20 ^{+5.9} ₋₀ { 2.0 ^{+0.6} ₋₀ }	29 ^{+9.8} ₋₀ { 3.0 ^{+1.0} ₋₀ }	49 ^{+9.8} ₋₀ { 5.0 ^{+1.0} ₋₀ }	54 ^{+4.9} ₋₀ { 5.5 ^{+1.0} ₋₀ }

Tightening torque for air piping nylon tube for general purpose {SAE type}

Unit: N · m {kgf · m}

Standard diameter	1/4 in.	3/8 in.	1/2 in.	5/8 in.
Tightening torque	13 ^{+3.9} ₋₀ { 1.3 ^{+0.4} ₋₀ }	29 ^{+4.9} ₋₀ { 3.0 ^{+0.5} ₋₀ }	49 ^{+4.9} ₋₀ { 5.0 ^{+0.5} ₋₀ }	64 ^{+4.9} ₋₀ { 6.5 ^{+0.5} ₋₀ }

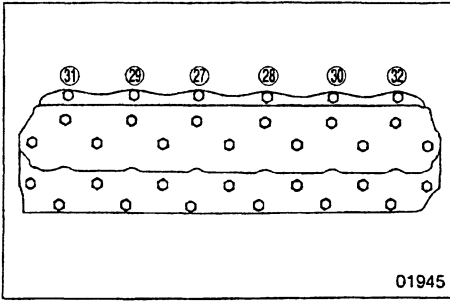

<M10 Bolts>

- After fitting the M14 cylinder head bolts 8, tighten the M10 bolts to the specified torque (34 N·m {3.5 kgf·m}) in the sequence shown.

11 Cylinder head gasket

[Removal]

CAUTION

When removing the cylinder head gasket 11, be careful not to scratch the cylinder head and valve assembly 10 and the crankcase *.

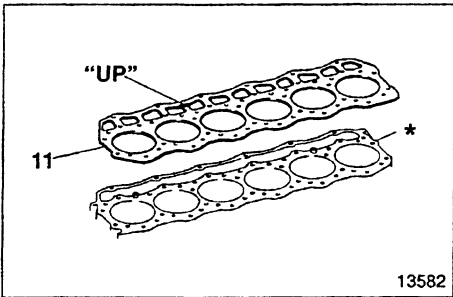

[Fitting]

- Fit the cylinder head gasket 11 onto the crankcase * as shown.

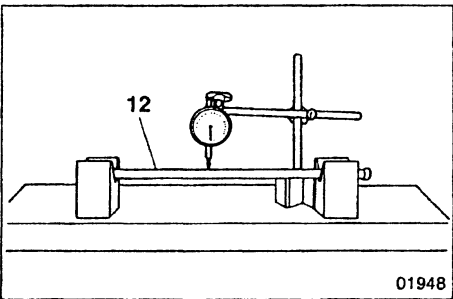

12 Push rod runout

If any measurement exceeds the specified limit, replace the defective part(s).

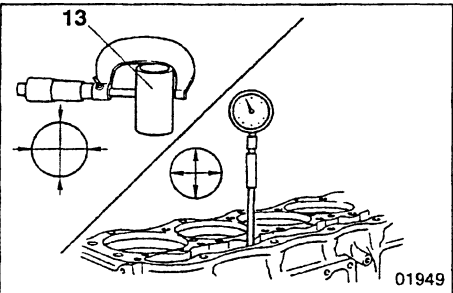

13 * Tappet-to-crankcase clearance

If any measurement exceeds the specified limit, replace the defective part(s).



Suggest:

For more complete manuals. Please go to the home page.

<https://www.ebooklibonline.com>

If the above button click is invalid. Please download this document first, and then click the above link to download the complete manual.

Thank you so much for reading

CYLINDER HEAD AND VALVE MECHANISM

Rocker and Bracket Assembly

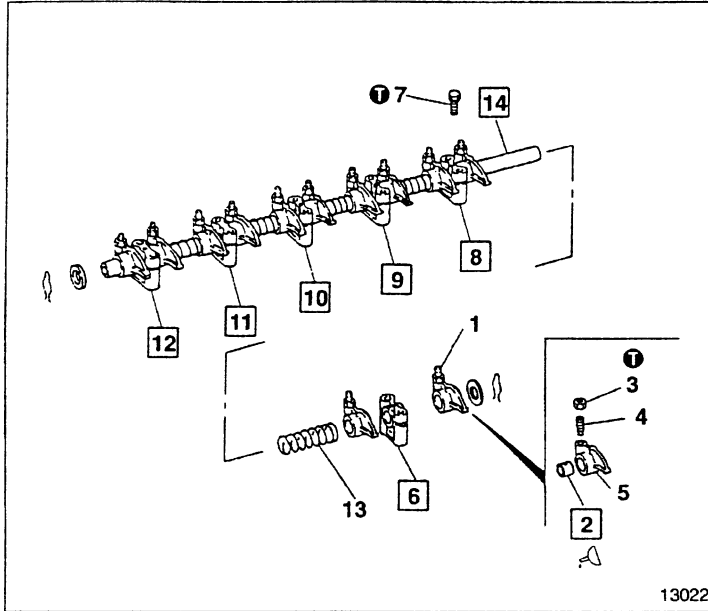

● Disassembly sequence

- 1 Rocker assembly
- 2 Rocker bushing
- 3 Lock nut
- 4 Adjusting screw
- 5 Rocker
- 6 No. 6 rocker shaft bracket
- 7 Set screw
- 8 No. 5 rocker shaft bracket
- 9 No. 4 rocker shaft bracket
- 10 No. 3 rocker shaft bracket
- 11 No. 2 rocker shaft bracket
- 12 No. 1 rocker shaft bracket
- 13 Rocker shaft spring
- 14 Rocker shaft

● Assembly sequence

Reverse the order of disassembly.

Service standards

Unit: mm

Location	Maintenance item	Standard value (Basic diameter in [])	Limit	Remedy
2, 14	Rocker bushing-to-rocker shaft clearance	[24] 0.01 to 0.08	0.12	Replace

① Tightening torques

Unit: N·m {kgf·m}

Location	Parts to be tightened	Tightening torque	Remarks
3	Adjusting screw lock nut	34 {3.5}	—
7	Rocker shaft set screw	3.9 {0.4}	—

⚠ Oils

Location	Points of application	Kinds	Quantity
2	Rocker bushing inner surface	Engine oil	As required

🔧 Special tools

Unit: mm

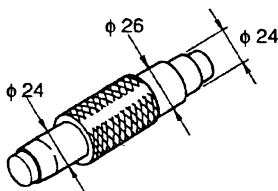
Location	Tool name and shape	Part No.	Application
2	Rocker Bushing Puller 	MH061777	Removing and installing rocker bushings

01951

◆ Service procedure

2 14 Rocker bushing and rocker shaft

[Inspection]

If any clearance exceeds the specified limit, replace the defective part(s).

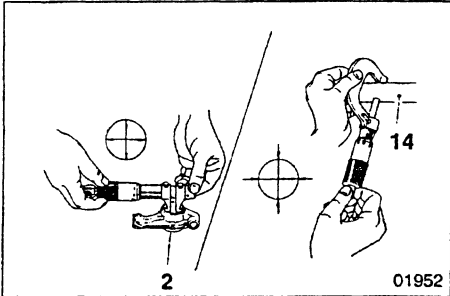

Rocker bushing

[Removal]

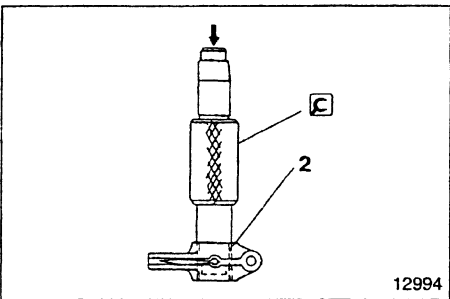

[Installation]

- Align the oil hole A in the rocker bushing 2 with the oil hole B in the rocker 5.
- Position the notch C and seam D on the rocker bushing 2 as shown.
- Install the rocker bushing 2 into the rocker 5 from the chamfered side F.

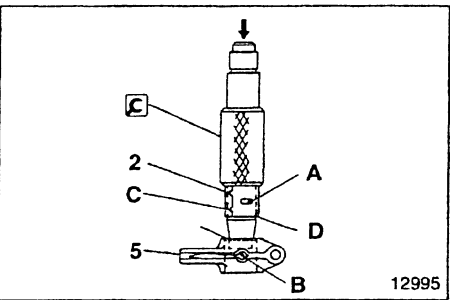

6 8 to 12 14 Installing rocker shaft brackets and rocker shaft

Rocker shaft brackets

Be sure to fit the rocker shaft brackets 6, 8, 12 in their correct positions.

- A: Oil hole
- B: Threaded hole (for M8 rocker cover bolt)
- C: Threaded hole (for M6 set screw)
- D: No threaded hole

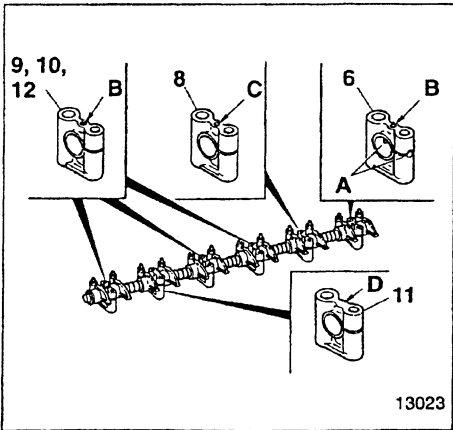

<https://www.ebooklibonline.com>

Hello dear friend!

Thank you very much for reading.

Enter the link into your browser.

The full manual is available for immediate download.

<https://www.ebooklibonline.com>