

KOBELCO

SHOP MANUAL

MITSUBISHI MOTORS

**6D1 DIESEL ENGINE
(INDUSTRIAL USE)**

97821-02021 NA

Issued 06-1988

6D1 500001~

6D1

ENGINE

Shop Manual

FOREWORD

This shop manual contains the specification, construction, operation, adjustment and service procedures of the Model 6D14, 6D14-T, 6D15, 6D15-T, 6D16, 6D16-T diesel engine for service mechanics engaged in servicing of the Mitsubishi diesel engines. Please make the most of this shop manual to perform correct servicing and wasteless operations. Note that some of the contents of this shop manual are subject to change owing to improvements, etc. that may be introduced after publication of this shop manual.

JUN. 1988

GROUP INDEX

GENERAL	00
ENGINE	11
LUBRICATION	12
FUEL AND ENGINE CONTROL	13
COOLING	14
INTAKE AND EXHAUST	15
ENGINE ELECTRICAL	16
CLUTCH	21
SPECIAL EQUIPMENT	61

Applicable Engine Models

6D14	}	For industrial use
6D14-T		
6D15		
6D15-T		
6D16		
6D16-T		

Applicable Engine No.

6D1■-500001~

ORGANIZATION – GROUP CLASSIFICATION

1. GROUP CLASSIFICATION

This manual is organized into several groups classified according to the engine basic elements.

No.	Group name	Description
00	General	External view, major specifications, engine outputs classified by application, engine numbers, nameplate, general precautions for servicing, general bolts and nuts tightening torque table, sealant and lubricant table
11	Engine	Engine proper (cylinder head, valve mechanism, camshaft, piston, crankshaft, timing gear, flywheel), flywheel PTO, specifications, service standards, special tools, troubleshooting
12	Lubrication	Lubrication system (oil pump, oil filter, oil cooler), specifications, service standards, special tools, troubleshooting
13	Fuel and engine control	Fuel system (injection pump, injection nozzle, fuel filter, pump drive case, water separator), specifications, service standards, special tools, troubleshooting
14	Cooling	Cooling system (water pump, thermostat, radiator, cooling system cleaning procedures, fan), specifications, service standards, special tools, troubleshooting
15	Intake and exhaust	Air cleaner, turbocharger, specifications, service standards, special tools, troubleshooting
16	Engine electrical	Starter, alternator, preheating system, relays, automatic stop device, specifications, service standards, troubleshooting
21	Clutch	Clutch proper, bearing case, specifications, service standards, special tools, troubleshooting
61	Special equipment	Air compressor, pressure governor, specifications, service standards, special tools

<https://www.ebooklibonline.com>

Hello dear friend!

Thank you very much for reading.

Enter the link into your browser.

The full manual is available for immediate download.

<https://www.ebooklibonline.com>

ORGANIZATION – TERMS AND UNITS, TABLE OF CONVERSION RATE FOR FOOT-POUND UNITS INTO SI UNITS

2. TERMS AND UNITS

The following terms and units are used throughout the entire texts of this manual.

(1) Front and Rear

The terms "front" is the fan side and "rear" the flywheel side of the engine.

(2) Right and Left

The terms "right" and "left" shall be used to indicate the side as viewed from the flywheel side of the engine.

(3) Service Standard Terms

- **Nominal value**
Shows the nominal dimensions, dimension of an individual part, standard clearance between parts in an assembly, or the standard performance of an assembly.
- **Limit**
Shows the value of a part at which the part is no longer serviceable from the performance as well as strength viewpoints, requiring replacement or repair.

(4) Tightening Torque

Over- or undertightening of bolts and nuts has critical effects on performance and functions.

Tightening torque is therefore specified for some tightening points.

All tightening torque specifications may be considered as "dry" unless "wet" is specified.

Where no tightening torque is specified, use a torque value specified in the General Bolts and Nuts Tightening Torque Table.

(5) Units

For length, weight, area, and volume, the SI unit (International System of Units) is used with the metric notation jointly shown in parentheses.

Temperature is shown in centigrade (°C).

3. TABLE OF CONVERSION RATE FOR FOOT-POUND UNITS INTO SI UNITS

Unit	Sign of SI unit	Sign of foot-pound unit	Conversion rate
Mass quantity of matter	kg g	lb oz	1 kg = 2.2046 lb 1 g = 0.035274 oz
Dimension	m mm	ft. in.	1 m = 3.2808 ft. 1 mm = 0.03937 in.
Capacity	lit. cc	gal. oz	1 lit. = 0.2642 gal. (U.S.) 1 lit. = 0.220 gal. (Imp.) 1 cc = 0.033814 oz (U.S.) 1 cc = 0.035195 oz (Imp.)
Force	N (Newton)	lbf	1 N = 0.2248 lbf
Pressure	kPa (kilopascal)	lbf/in. ²	1 kPa = 0.145 lbf/in. ² 1 kPa = 0.2953 in.Hg
Stress	N/cm ²	lbf/in. ²	1 N/cm ² = 1.45 lbf/in. ²
Moment of force	Nm	ft. lbf	1 Nm = 0.7375 ft. lbf
Output	kW (kilowatt)	HP	1 kW = 1.34 HP
Temperature	°C	°F	°C = (1.8°C + 32)°F

ORGANIZATION – READING THE ILLUSTRATION

4. READING THE ILLUSTRATION

(Ex. 1: Disassembly and Inspection)

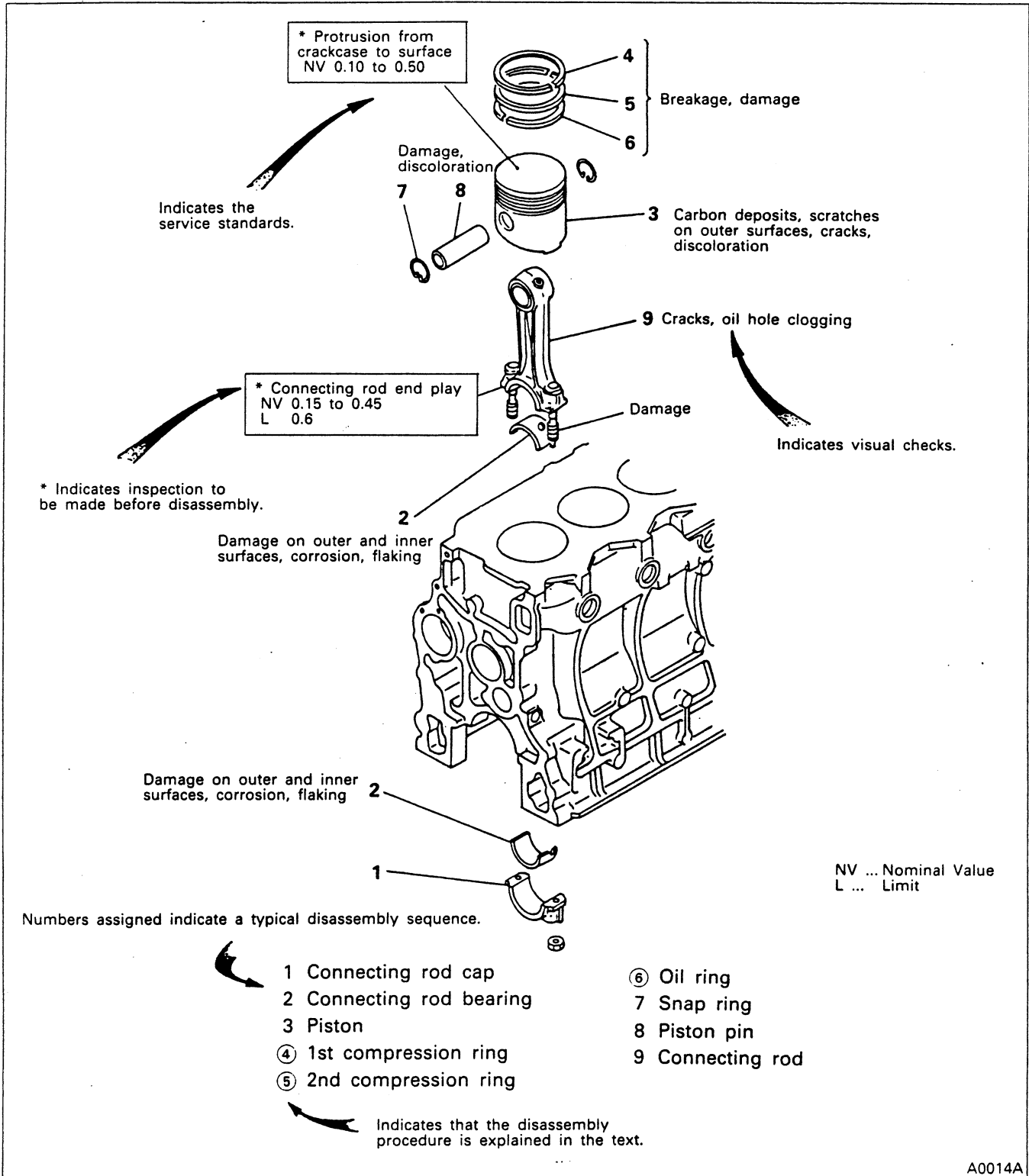

A0014A

ORGANIZATION – READING THE ILLUSTRATION

(Ex. 2: Reassembly)

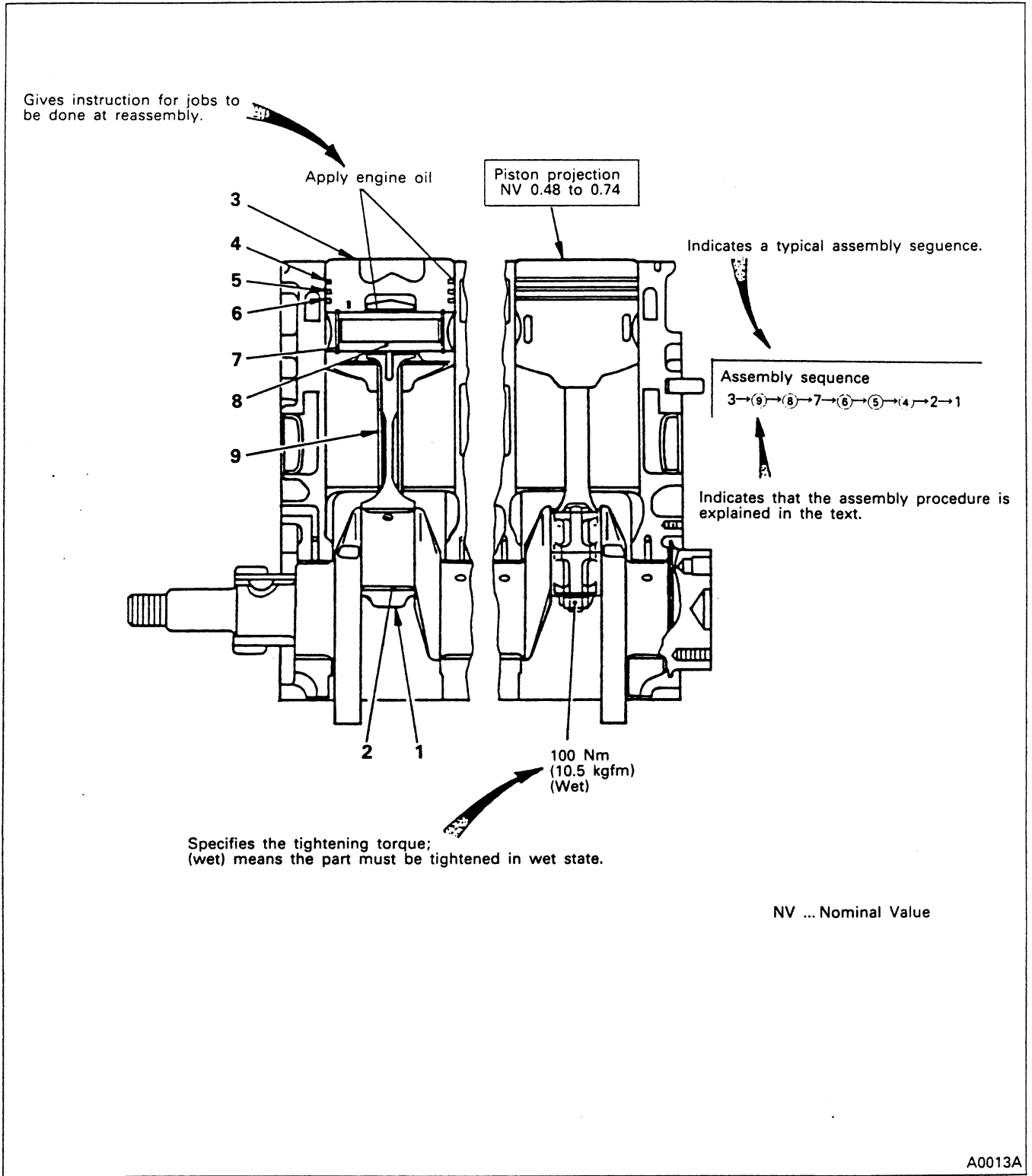

(1) Illustrations (exploded views and assembly drawings) show a typical service procedures if it is

identical among various types of available systems and units.

NOTES

GENERAL

CONTENTS

1. EXTERNAL VIEW	8	4. GENERAL PRECAUTIONS FOR	
2. MAJOR SPECIFICATIONS	10	SERVICING	12
2.1 Major Specifications	10	5. GENERAL BOLTS AND NUTS TIGHTENING	
2.2 Engine Outputs Classified by		TORQUE TABLE	13
Application	10	6. SEALANT, OIL AND GREASE	14
3. ENGINE NUMBER AND NAMEPLATE	11		

1. EXTERNAL VIEW

<Natural-aspirated engine>

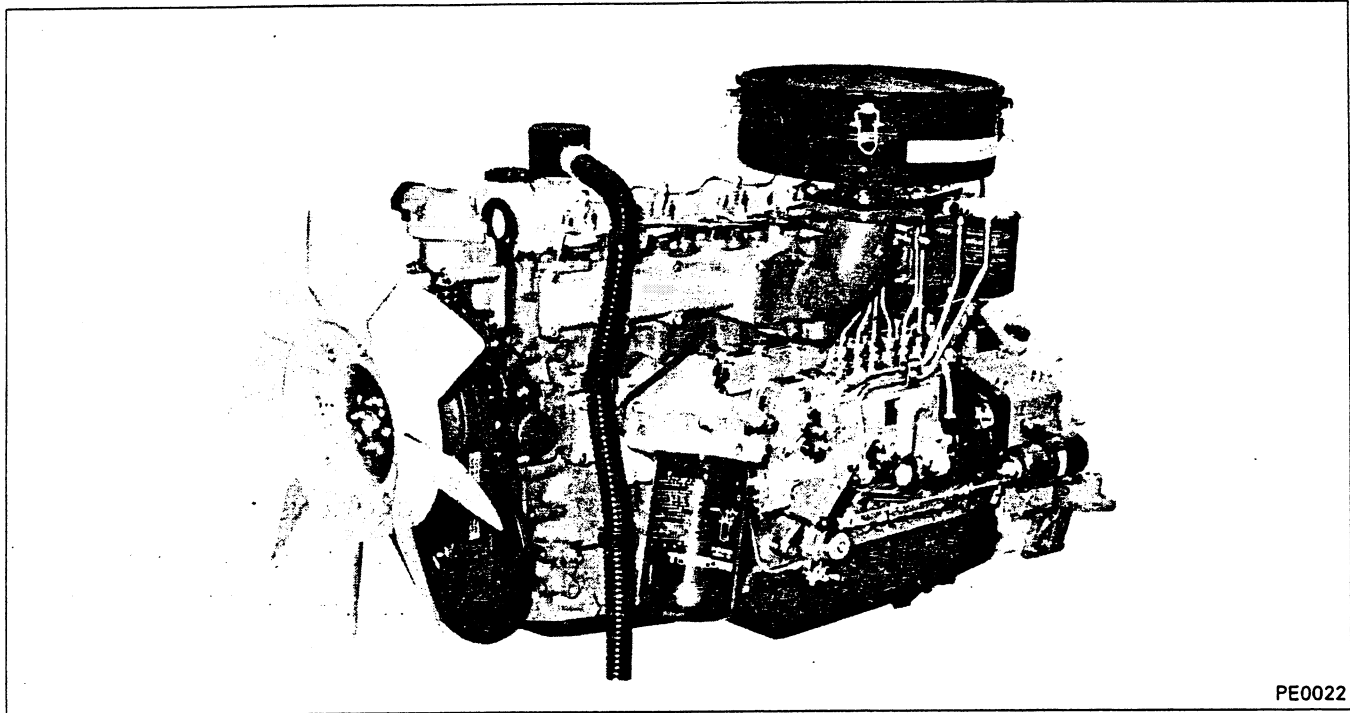

PE0022

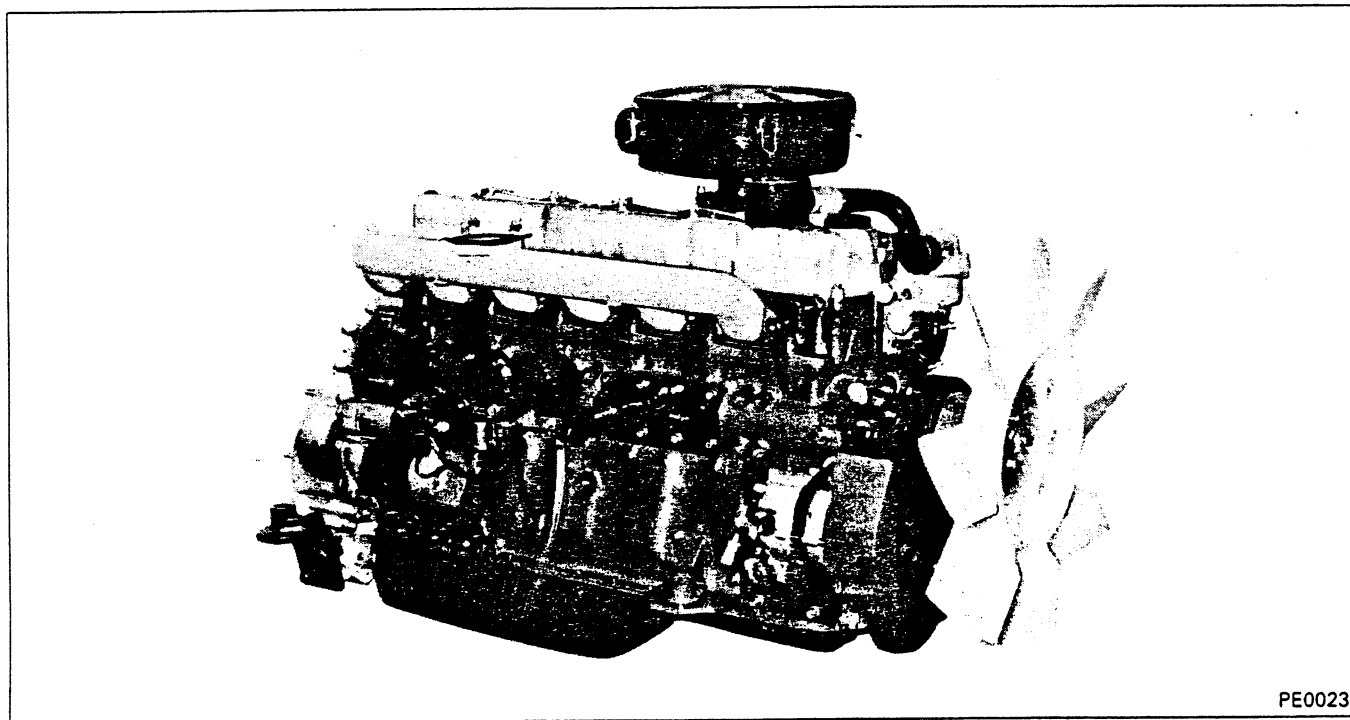

PE0023

* This photo shows the model 6D14.

<Turbocharged engine>

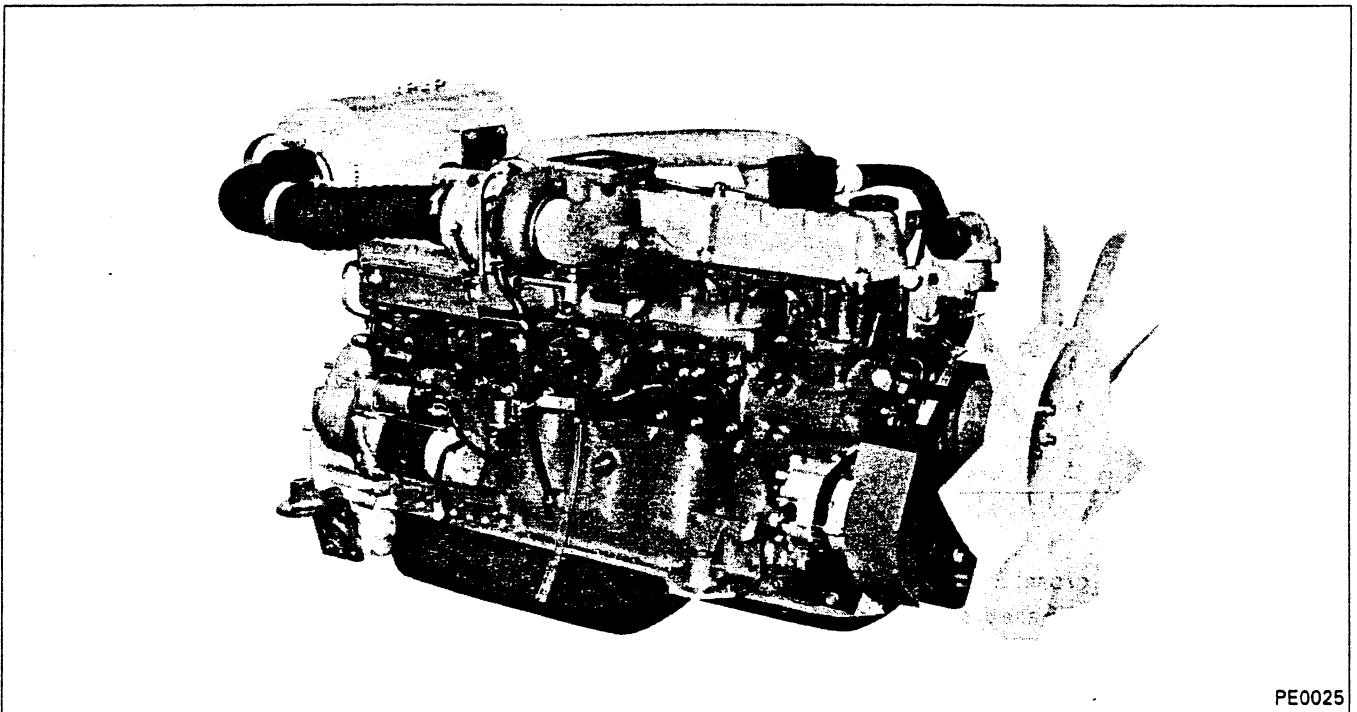
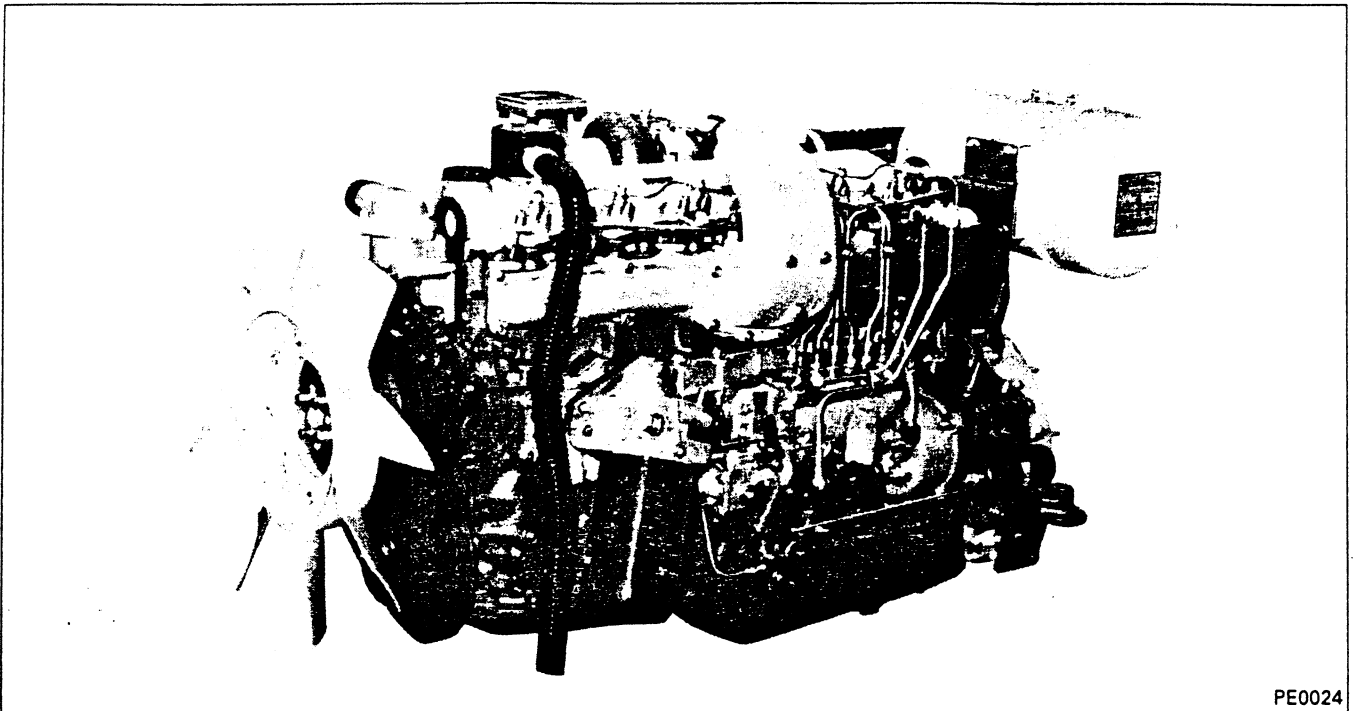

* This photo shows the model 6D14-T.

2. MAJOR SPECIFICATIONS

2.1 Major Specifications

Engine model	6D14	6D14-T (with turbochager)	6D15	6D15-T (with turbocharger)	6D16	6D16-T (with turbocharger)
Item						
Type	Diesel, 4-cycle, water-cooled	Diesel, 4-cycle, water-cooled	Diesel, 4-cycle, water-cooled	Diesel, 4-cycle, water-cooled	Diesel, 4-cycle, water-cooled	Diesel, 4-cycle, water-cooled
Combustion method	Direct injection	Direct injection	Direct injection	Direct injection	Direct injection	Direct injection
No. and arrangement of cylinder	6 in-line	6 in-line	6 in-line	6 in-line	6 in-line	6 in-line
Cylinder bore x stroke mm	110 x 115	110 x 115	113 x 115	113 x 115	118 x 115	118 x 115
Total displacmenet cc	6557	6557	6919	6919	7545	7545
Engine dimension (without fan)						
Overall length mm	1209	1209	1209	1209	1209	1209
Overall width mm	752	731	752	731	752	731
Overall height mm	841	833	841	833	841	833
Empty weight kg*	500	510	505	520	520	550

* Empty weight as measured according to Mitsubishi Motors Corporation standard.

2.2 Engine Outputs Classified by Application

Engine model	6D14	6D14-T (with turbocharger)		6D16	6D16-T (with turbocharger)	
		Middle-speed specification	High-speed specification		Middle-speed specification	High-speed specification
Intermittent rated output kW (HP)/rpm	60 (80)/1500	84 (112)/1500	81 (108)/1500	73 (98)/1500	108 (145)/1500	104 (139)/1500
	72 (96)/1800	100 (134)/1800	97 (130)/1800	87 (116)/1800	125 (168)/1800	123 (166)/1800
	79 (105)/2000	109 (146)/2000	106 (142)/2000	95 (128)/2000	134 (180)/2000	134 (179)/2000
	84 (112)/2200	114 (153)/2200	114 (153)/2200	103 (139)/2200	143 (192)/2200	142 (190)/2200
	90 (121)/2500		122 (163)/2500	113 (152)/2500		150 (201)/2500
	94 (126)/2800		128 (171)/2800	123 (165)/2800		154 (207)/2800
Continuous rated output kW (HP)/rpm	54 (72)/1500	77 (103)/1500	73 (98)/1500	66 (89)/1500	98 (132)/1500	94 (126)/1500
	65 (87)/1800	92 (123)/1800	88 (118)/1800	79 (106)/1800	114 (153)/1800	112 (151)/1800
	71 (95)/2000	98 (131)/2000	96 (128)/2000	87 (116)/2000	122 (164)/2000	121 (163)/2000
	76 (102)/2200	103 (138)/2200	103 (149)/2500	94 (126)/2200	130 (174)/2200	129 (173)/2200
	82 (110)/2500		111 (149)/2500	103 (139)/2500		136 (182)/2500
	85 (115)/2800		117 (157)/2800	112 (150)/2800		140 (188)/2800

NOTE:

1. The output (SAE, gross) is corrected to standard ambient conditions based on SAE J1349.
2. The continuous rated output allows 10% (one hour) overload operation.

3. ENGINE NUMBER AND NAMEPLATE

(1) Engine number

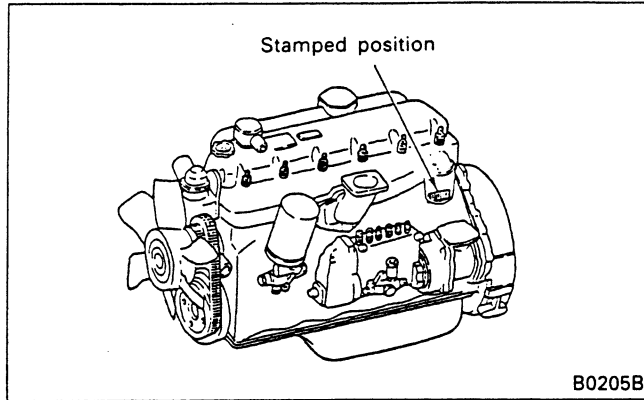

The engine number is stamped on the position as illustrated.

Example: 6D16 – 500001

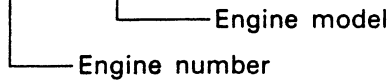

The engine number is important in knowing the history of the engine.

(2) Nameplate

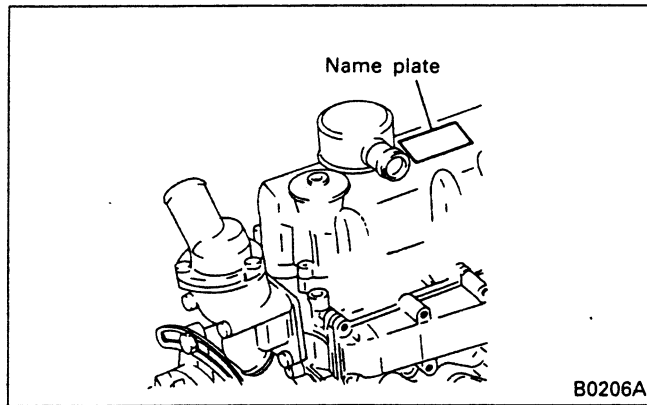

The nameplate is attached to the portion as illustrated. The nameplate bears the followings:

A detailed diagram of a nameplate with numbered callouts 1 through 6. The nameplate contains the following text:

- 1: A blank box for the engine model.
- 2: TOTAL CYL. VOL. 6557cc (400cu. in)
- 3: OUT PUT [] [] / [] rpm
- MITSUBISHI MOTORS CORPORATION
- TOKYO JAPAN
- 4: VALVE CLEARANCE (COLD)
- INLET & EXHAUST 0.4mm (0.16 in)
- 5: FIRING ORDER 1-5-3-6-2-4
- 6: FUEL INJECTION TIMING [] BTDC

A legend below the nameplate identifies the callouts:

- 1 Engine model
- 2 Total displacement
- 3 Rated output
- 4 Valve clearance
- 5 Firing order
- 6 Fuel injection timing

The engine number 'B0207B' is printed in the bottom right corner of the diagram.

4. GENERAL PRECAUTIONS FOR SERVICING

Before starting the service procedures, check the vehicle for total time driven, use conditions, and user's complaints and requests to know exactly the engine conditions. Record information where necessary.

To ensure you are doing correct and efficient service jobs, observe the following precautions:

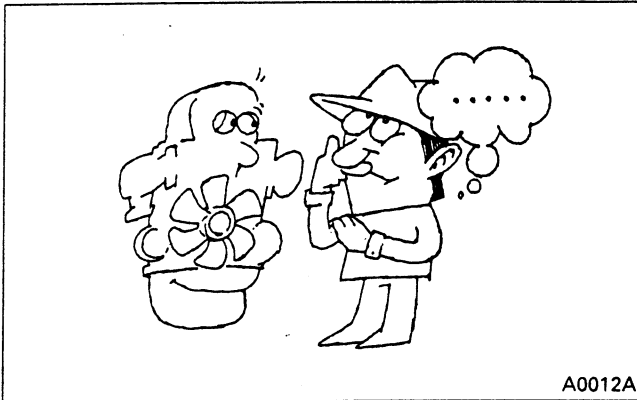

A0012A

- (1) Before performing the service procedures given in this manual, know the trouble spots and isolate the possible cause to determine whether the removal or disassembly procedure is required.
- (2) Select a flat surface for the service job.
- (3) When servicing the electrical system, be sure to disconnect the negative cable from the battery.
- (4) Carefully check parts for oil leaks before cleaning. After cleaning, it may become difficult to spot defective areas.
- (5) Ready and make the most of the special tools required for servicing. Use the right tools (specified special tools) in the right place to prevent damages to parts and personal injury.
- (6) Make alignment marks and keep disassembled parts neatly arranged to ensure that they are reassembled into the right positions.
 - Special care must be taken for assemblies involving a number of parts, similar parts, or parts identical at right- and left-hand sides to ensure correct reassembly.
 - For alignment and punching markings, select a position that would not mar the appearance and function.
 - Clearly distinguish parts to be replaced from those reused.

**MITSUBISHI MOTORS
GENUINE PARTS**

A0006A

- (7) The oil seals, packings, O-rings, and other rubber parts, gaskets, and split pins must be replaced with a new one whenever they are removed. For replacement, use Mitsubishi Genuine parts.

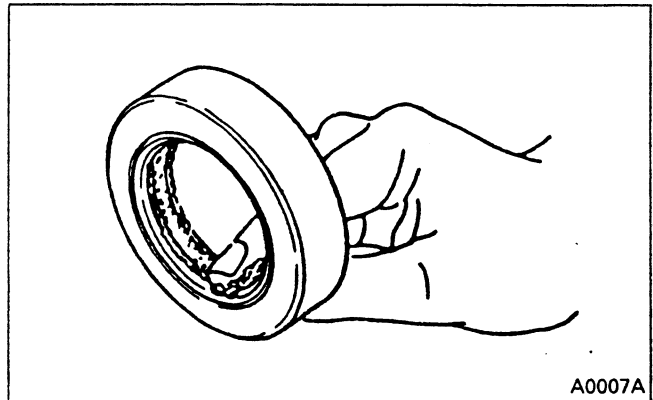

A0007A

- (8) Apply the specified grease to U-packings, oil seals, dust seals, and bearings before installation.
- (9) When work requires an assistant or two, always make sure of the safety each other. Never play with switches and levers.
- (10) Make sure that your shoes are free from grease and oil especially when working on a heavy item.
- (11) When checking or changing lubricants, wipe off grease and oil from parts immediately with a waste.
- (12) Special care must be taken in handling sensors and relays which are susceptible to shocks and heat.
- (13) Use care so that hands and fingers are not injured by sharp edges or corners of the parts.
- (14) Wear safety goggles whenever handling a grinder or welding machine. Wear gloves as required to ensure utmost safety.

5. GENERAL BOLTS AND NUTS TIGHTENING TORQUE TABLE

Unless otherwise specified, the parts and equipment of vehicle must be tightened by the following standard bolts and nuts. Tightening torques for these bolts and nuts are shown below.

NOTE:

1. Threads and seat surfaces must be in dry state.
2. When there is a difference between the nut and bolt (stud) identification marks, tighten to the torque corresponding to the bolt (stud) identification mark.

Standard bolts and nuts

Unit: Nm (kgfm)

Dia. mm	Pitch mm	4T (Head mark 4 or ○)	7T (Head mark 7 or ⊖)	8T (Head mark 8 or ⊕)
5	0.8	2.0 to 2.9 (0.2 to 0.3)	3.9 to 5.9 (0.4 to 0.6)	4.9 to 6.9 (0.5 to 0.7)
6	1.0	3.9 to 5.9 (0.4 to 0.6)	6.9 to 10.8 (0.7 to 1.1)	7.8 to 11.8 (0.8 to 1.2)
8	1.25	8.8 to 13.7 (0.9 to 1.4)	16.7 to 25.5 (1.7 to 2.6)	19.6 to 29.4 (2.0 to 3.0)
10	1.25	18.6 to 27.5 (1.9 to 2.8)	34.3 to 53.9 (3.5 to 5.5)	44.1 to 58.8 (4.5 to 6.0)
	1.5	17.7 to 26.5 (1.8 to 2.7)	32.4 to 49.0 (3.3 to 5.0)	42.1 to 58.8 (4.3 to 6.0)
12	1.25	33.3 to 49.0 (3.4 to 5.0)	68.6 to 93.2 (7.0 to 9.5)	83.4 to 108 (8.5 to 11)
	1.75	30.4 to 46.1 (3.1 to 4.7)	63.7 to 83.4 (6.5 to 8.5)	73.5 to 98.1 (7.5 to 10)
14	1.5	58.8 to 83.4 (6.0 to 8.5)	118 to 157 (12 to 16)	127 to 177 (13 to 18)
	2.0	53.9 to 73.5 (5.5 to 7.5)	108 to 137 (11 to 14)	118 to 167 (12 to 17)
16	1.5	93.2 to 127 (9.5 to 13)	177 to 235 (18 to 24)	196 to 265 (20 to 27)
	2.0	88.3 to 118 (9.0 to 12)	157 to 216 (16 to 22)	186 to 255 (19 to 26)

Flange bolts and nuts

Unit: Nm (kgfm)

Dia. mm	Pitch mm	4T (Head mark 4 or ○)	7T (Head mark 7 or ⊖)	8T (Head mark 8 or ⊕)
6	1.0	3.9 to 5.9 (0.4 to 0.6)	7.8 to 11.8 (0.8 to 1.2)	8.8 to 13.7 (0.9 to 1.4)
8	1.25	9.8 to 14.7 (1.0 to 1.5)	18.6 to 27.5 (1.9 to 2.8)	21.6 to 32.4 (2.2 to 3.3)
10	1.25	20.6 to 30.4 (2.1 to 3.1)	38.2 to 58.8 (3.9 to 6.0)	49.0 to 63.7 (5.0 to 6.5)
	1.5	18.6 to 28.4 (1.9 to 2.9)	35.3 to 53.0 (3.6 to 5.4)	44.1 to 63.7 (4.5 to 6.5)
12	1.25	37.3 to 53.9 (3.8 to 5.5)	78.5 to 108 (8.0 to 11)	88.3 to 118 (9.0 to 12)
	1.75	33.3 to 51.0 (3.4 to 5.2)	68.6 to 93.2 (7.0 to 9.5)	83.4 to 108 (8.5 to 11)

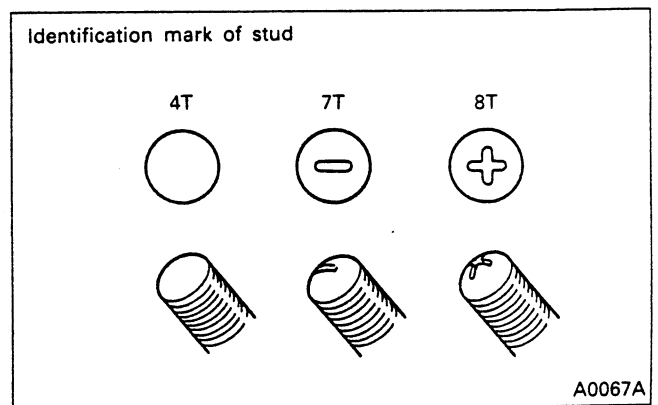
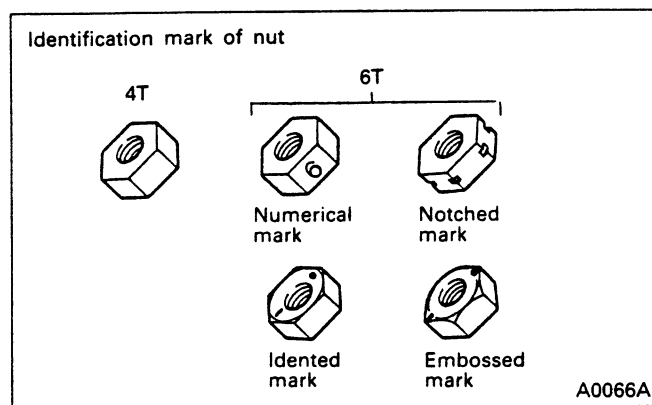

6. SEALANT, OIL AND GREASE

GROUP 11 ENGINE

Description	Sealant, oil and grease	Application method
Nozzle tube	THREEBOND 1211 or equivalent	Apply to nozzle tube end which fits in cylinder head.
Crankcase	THREEBOND 1104 or equivalent	Apply to joining surfaces of rear plate and crankcase.
Flywheel housing	THREEBOND 1105 or equivalent	Apply to joining surfaces of rear plate and flywheel housing.
Front oil seal	Multipurpose type grease	Apply to lips.
Flywheel PTO oil seal		

GROUP 14 COOLING

Description	Sealant, oil and grease	Application method
Water pump case	Multipurpose type grease	Pack 60 g in case.
Water pump unit seal external cylindrical portion	THREEBOND 1102 or equivalent	Apply to portion which fits in case.

GROUP 15 INTAKE AND EXHAUST

Description	Sealant, oil or grease	Application method
Center housing to turbine housing mounting bolt <T04B>	MOLYCOAT or equivalent	Apply to threaded portion and seat surface.
Compressor wheel nut <TD07>		Apply to threaded portion.
Coupling <TD07>		

GROUP 16 ENGINE ELECTRICAL

Description	Sealant, oil and grease	Application method
Reduction gear	MULTEMP PS No. 2 (Kyodo Yushi Ind. Co.) or equivalent	Apply to gear.
Rear bracket		Pack rear portion.
Pinion shaft stopper		Apply to contacting surfaces.
Plunger		Apply to contacting surfaces.
Lever		Apply to contacting surfaces.
Sleeve bearing		Apply to inside.
Pinion		Apply to splines.

GENERAL – SEALANT, OIL AND GREASE

00

GROUP 21 CLUTCH

	Description	Sealant, oil and grease	Application method
Clutch proper	Pressure plate and release lever sliding position	Molybdenum disulfide grease	Apply to sliding surface.
	Release lever and support lever sliding position		
	Release lever and release lever plate sliding position <C4, C5>		
Bearing case	Clutch shaft	MOLYCOAT BR2 PLUS or equivalent	Apply to splines.
	Clutch shifter	Heat-resisting grease	Pack
	Clutch fork shaft		Apply to grease nipple.
	Bearing case <PC4> (direct drive type)	Multipurpose type grease	
	Between oil seal cover, bearing case A and bearing case B <PC4> (belt drive type)	THREEBOND 1102C or equivalent	Apply to both surface.
	Bearing case A and bearing retainer contacting surface <PC8>		
	Bearing case B, bearing case A and oil seal cover contacting surface <PC8>		
	Bearing case A and clutch housing contacting surface <PC8>	THREEBOND 1104 or equivalent	

NOTES

ENGINE

CONTENTS

1. GENERAL	18	5.1.2 Cylinder head and valve mechanism	35
1.1 Engine Proper	18	5.1.3 Flywheel, timing gears and camshaft	47
1.2 Flywheel PTO	23	5.1.4 Crankcase and main moving parts	57
2. SPECIFICATIONS	24	5.1.5 Inspection and adjustment of valve clearance	77
3. SERVICE STANDARDS	25	5.2 Flywheel PTO (Option)	78
3.1 Service Standards Table	25	5.2.1 Disassembly and inspection	78
3.2 Tightening Torque Table	28	5.2.2 Reassembly	80
4. SPECIAL TOOL	29	6. TROUBLESHOOTING	81
5. SERVICE PROCEDURE	34		
5.1 Engine Proper	34		
5.1.1 Measurement of compression pressure	34		

1. GENERAL

1.1 Engine Proper

(1) Combustion chamber

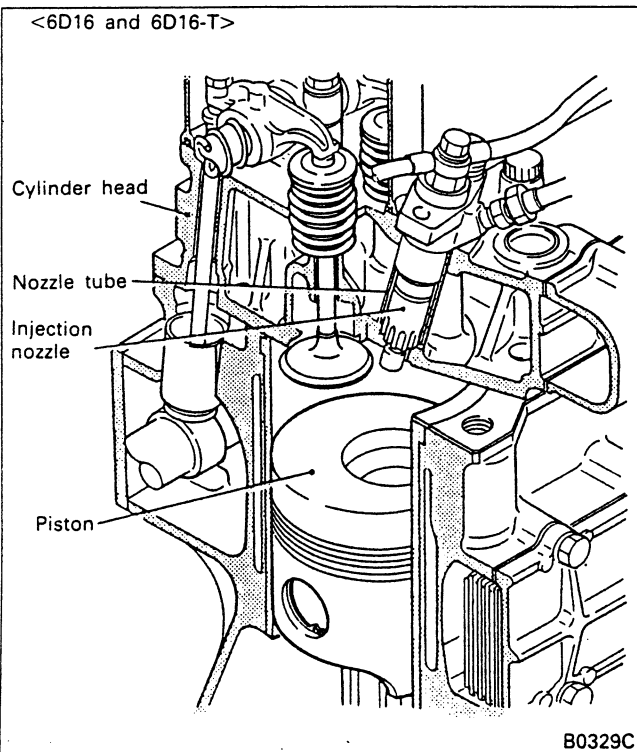
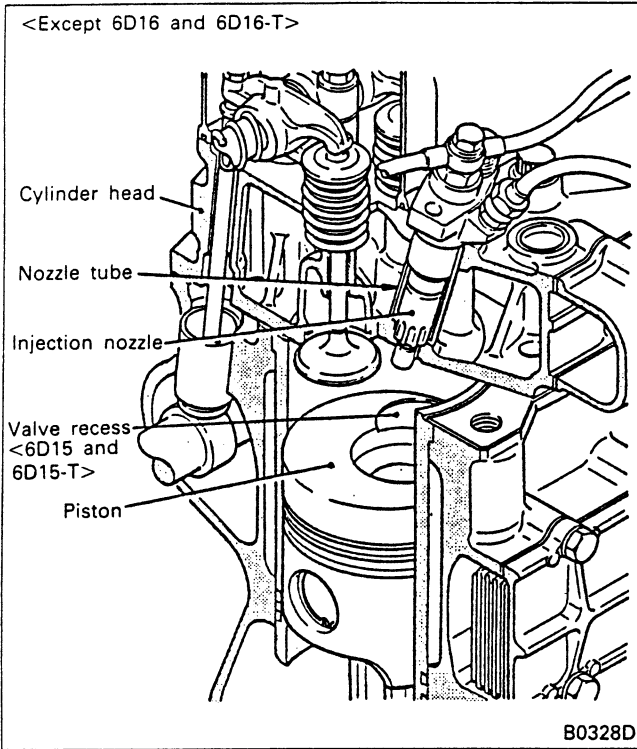

The combustion chamber is made up of the cylinder head and piston top. The hole type injection nozzle as well as the nozzle tube is mounted on the cylinder head. The nozzle tube holds the nozzle in position and protects the nozzle from coolant. Since the outside of the nozzle tube is exposed to the water jacket, the top end of the tube is sealed off with an O-ring and the bottom end staked to prevent entrance of water. Combustion is accomplished by compressing the fuel directly injected into the combustion chamber. On 6D15 and 6D15-T engine, a valve recess is provided at the cylinder top to ensure clearance between piston and exhaust valve.

(2) Valve mechanism

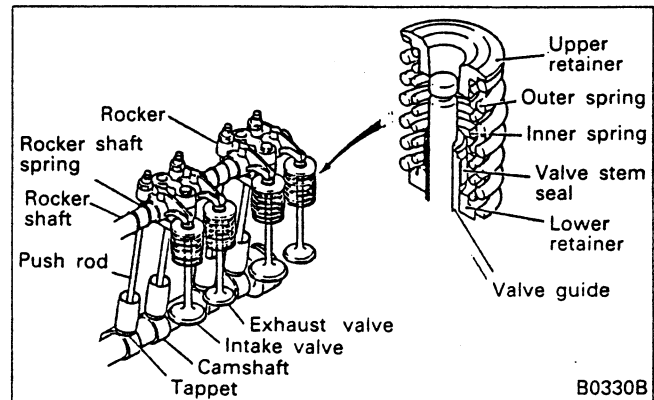

(a) Both the intake and exhaust valves are made of surface-treated heat-resistant steel. The valve seat angle is 45° for both valves.

Valve stem seal is mounted to the valve stem, which controls the amount of lubricant on the sliding surfaces between the valve and valve guide.

A valve guide with carbon cutter is used for the exhaust valve.

(b) Two unevenly pitched valve springs are used to prevent chattering at high speed. The inner and outer spring coil directions are opposite to each other.

(c) The rockers are made of precisely forged carbon steel. The end sliding portions of the rockers has been quenched. The rocker shaft is a hollow round rod sealed off with expansion plugs at both ends. The inside of the shaft serves as an engine oil passage.

(d) The push rod has a steel ball welded to its bottom end and a spherical or depressed piece welded to its top end. Both ends are carburized case-hardened.

- (e) The tappet is of cylindrical shape. Its mating surface with the camshaft is a large-diameter sphere to prevent local wear. The tappet can be removed by removing the cylinder head without removing the camshaft.
 - (f) Excellent reliability at high speed has been achieved by adopting a high camshaft which permits the use of shorter push rods with high rigidity.
 - (g) To facilitate the insertion and removal of the camshaft from the rear end of the case, the bearing I.D. is narrower toward the front.
- (3) Crankcase and cylinder liner

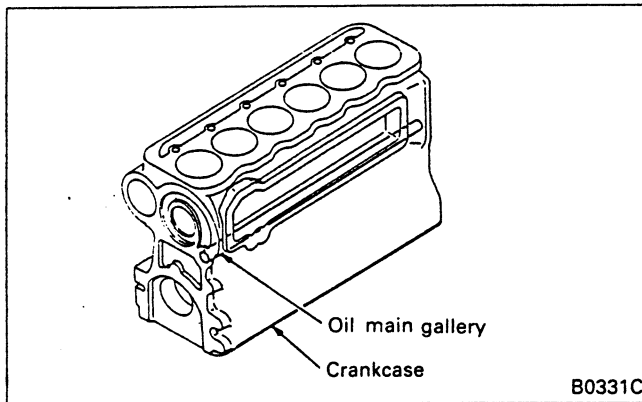

- (a) The crankcase is made of cast iron, provided with ribs to ensure high rigidity, and built with minimum stress concentration and deformation.
- (b) The oil main gallery is located on the right side as viewed from the front and supplies the engine oil that has passed through the oil filter and oil cooler to various sections. Engines other than the 6D14 and 15 series have an oil jet provided for each cylinder to cool the piston. (Refer to Group 12 LUBRICATION.)
- (c) Cooling water that has entered the water jacket cools the cylinders before it flows to the cylinder head.

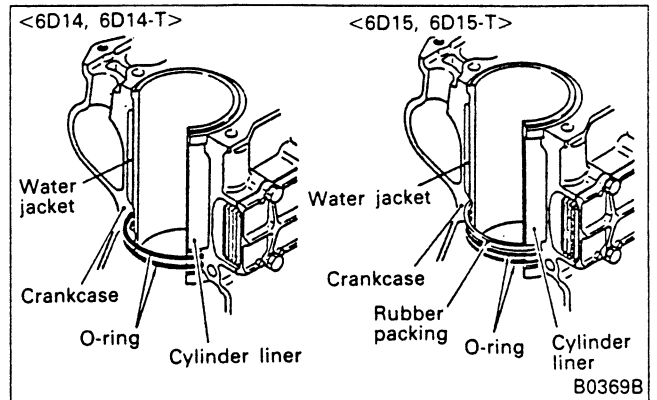

- (d) The cylinder liner other than 6D16, 6D16-T engines is of the wet type that is removable. It engages with the crankcase at the top of the crankcase and at the bottom of the water jacket. An O-ring and rubber packing are used to prevent water leaks. 6D14 and 6D14-T engines have an O-ring groove provided on the crankcase side and 6D15 and 6D15-T engines on the cylinder liner side.

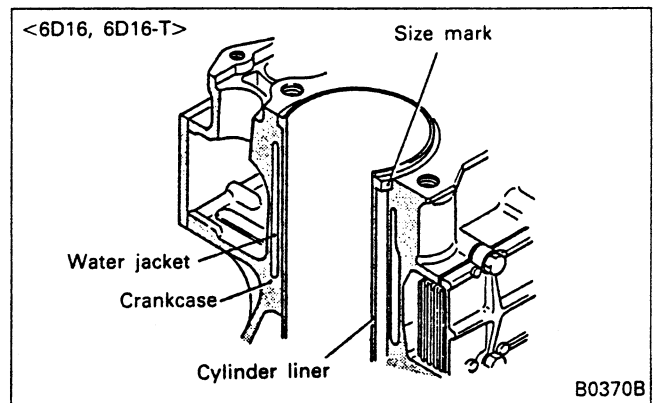

- The cylinder liner for 6D16 and 6D16-T engines is of the dry type that is mounted with the crankcase so that it can be easily removed. A size mark is stamped on the side of the cylinder liner collar to permit a correct fit with the crankcase.

(4) Piston and piston ring

(a) Piston

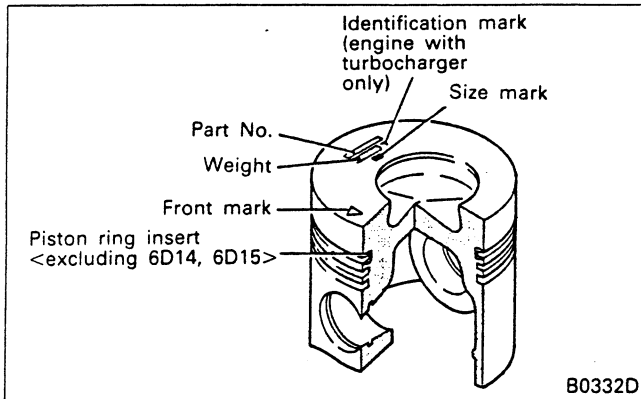

The piston is made of an aluminum alloy casting with a trochoidal type combustion chamber (6D15-T, 6D16-T) or re-entrant type combustion chamber (other models) provided at the top.

Engines other than 6D14 and 6D15 have a piston ring insert cast in the 1st ring groove for higher durability. The part No., weight, and size mark are stamped on top of the piston as shown above. A triangle mark indicating the piston mounting direction is also embossed on the piston.

The piston pin is mounted using the full floating method, offset from the cylinder center.

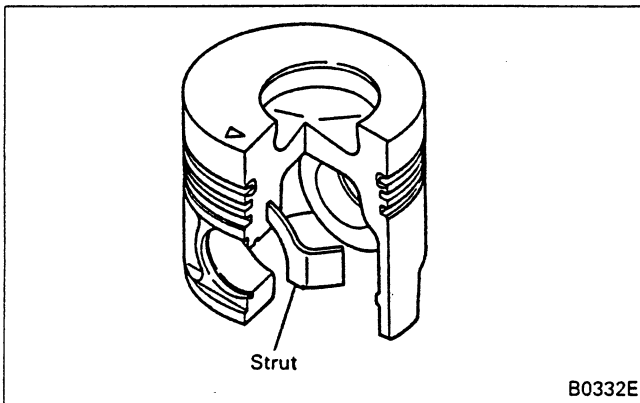

The pistons for the 6D16 engine have an internal strut to reduce piston slap noise.

(b) Piston ring

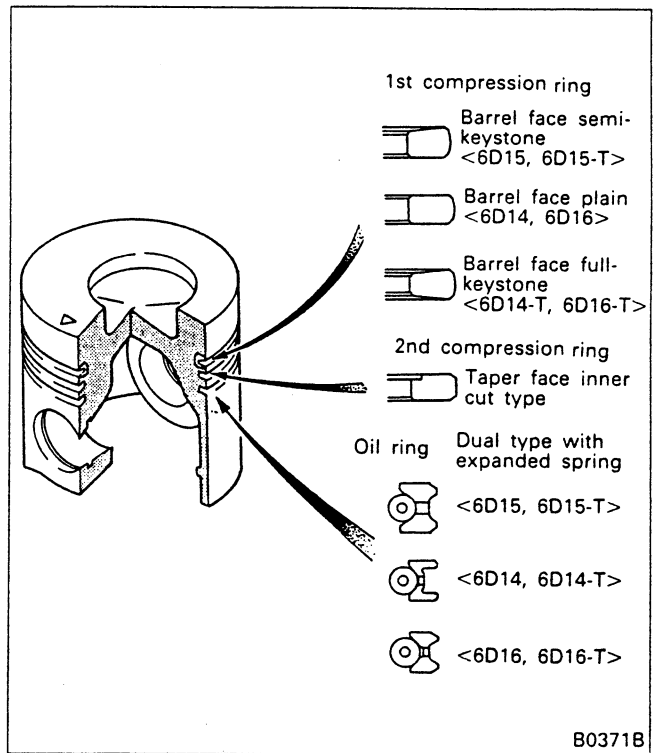

The piston ring set consists of three rings, namely, two compression rings and one oil ring, all these having chromium plated sliding surfaces for higher wear resistance.

The shapes of piston rings are as illustrated.

(5) Connecting rod and connecting rod bearing

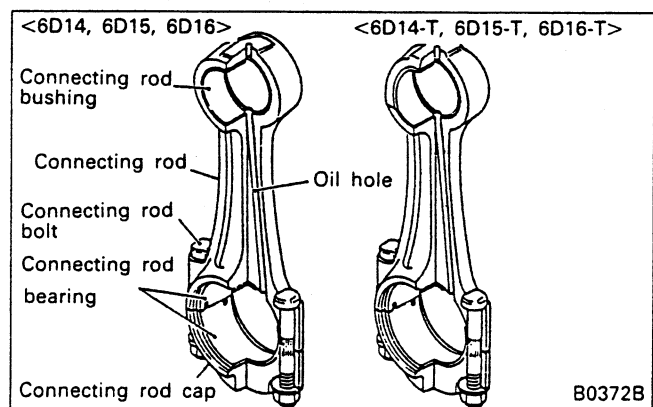

The connecting rod is a die-forged part with I-section. It has a lead bronze bushing press fitted at the small end and a split type plain bearing fitted at the big end of the connecting rod.

This bearing is made of kelmet with a soft copper back plate whose inside surface has been plated with a lead, tin and copper alloy before plating the entire bearing with tin.

The connecting rod and its cap are connected by knurled connecting bolts.

For lubrication of the small end, the stem has a diagonally oriented oil passage. The connecting rod for 6D14-T, 6D15-T and 6D16-T has its small end wedge shaped to decrease piston boss plane pressure, thereby reducing mechanical stress in the piston.

(6) Crankshaft and main bearing

(a) Crankshaft

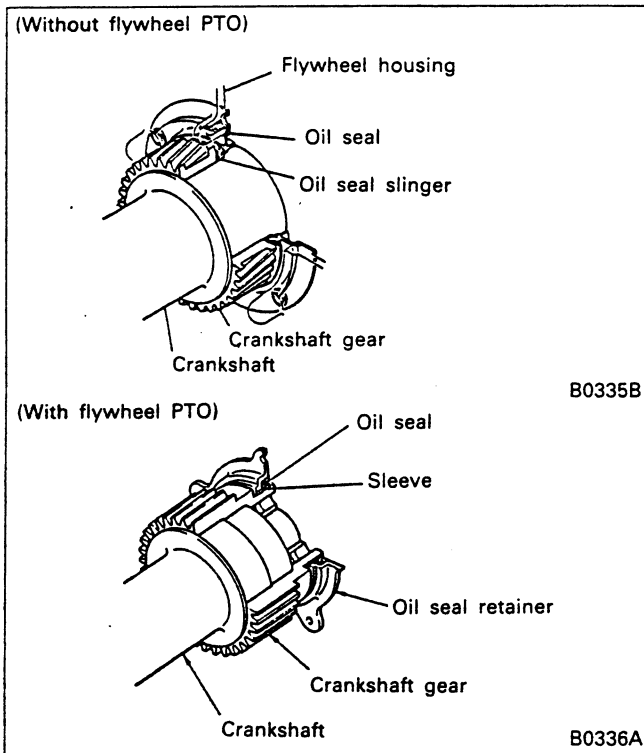

The crankshaft is die-forged integrally with the balance weight and is supported by the main bearing in the crankcase.

The pin and journal are induction hardened for higher wear resistance. An oil hole passes between the journal and pin, and part of the main bearing lubrication oil flows through the hole to the pin for lubrication of the connecting rod bearing.

At the rear end of the crankshaft, the crankshaft gear is engaged to drive the timing gear.

The crankshaft has oil seals fitted at its front and rear ends. The rear oil seal type is as follows.

- Without flywheel PTO: Axial lip type
- With flywheel PTO: Radial lip type

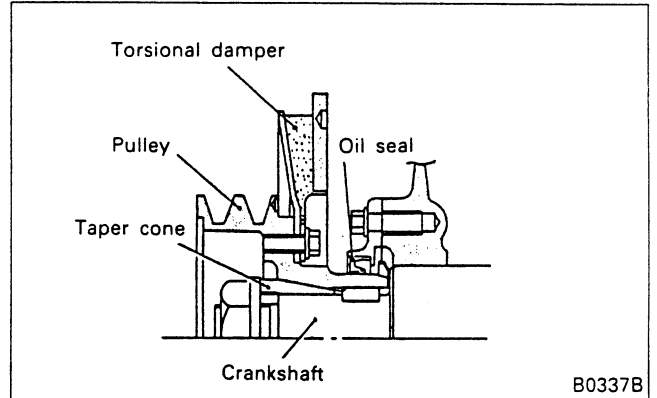

The crankshaft has a pulley and torsional damper at the front end. The damper prevents torsional vibration of the crankshaft.

(b) Main bearing

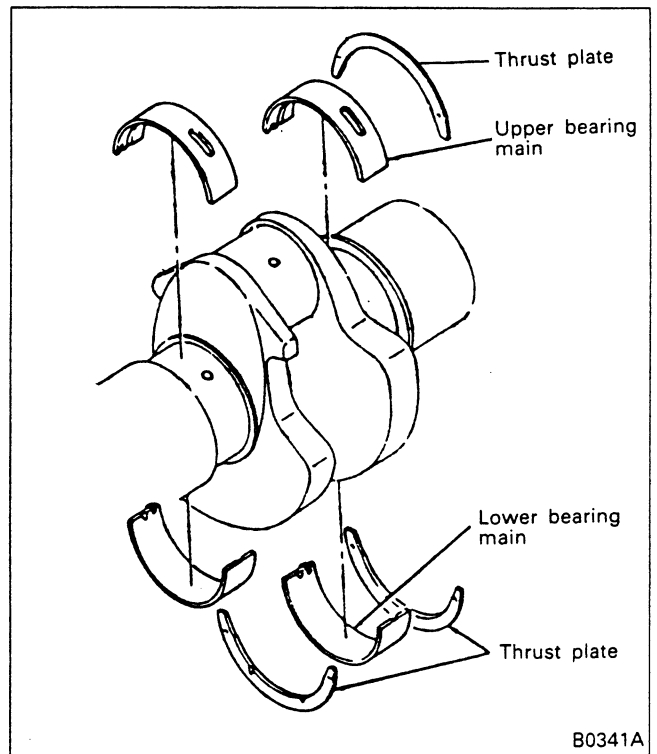

The main bearing is a split type plain bearing made of the same material as the connecting rod bearing. The upper bearing is has an oil groove but the lower bearing does not.

A split type thrust plate is installed at the rearmost section which bears the thrust force of the crankshaft.



Suggest:

For more complete manuals. Please go to the home page.

<https://www.ebooklibonline.com>

If the above button click is invalid. Please download this document first, and then click the above link to download the complete manual.

Thank you so much for reading

(7) Timing gears

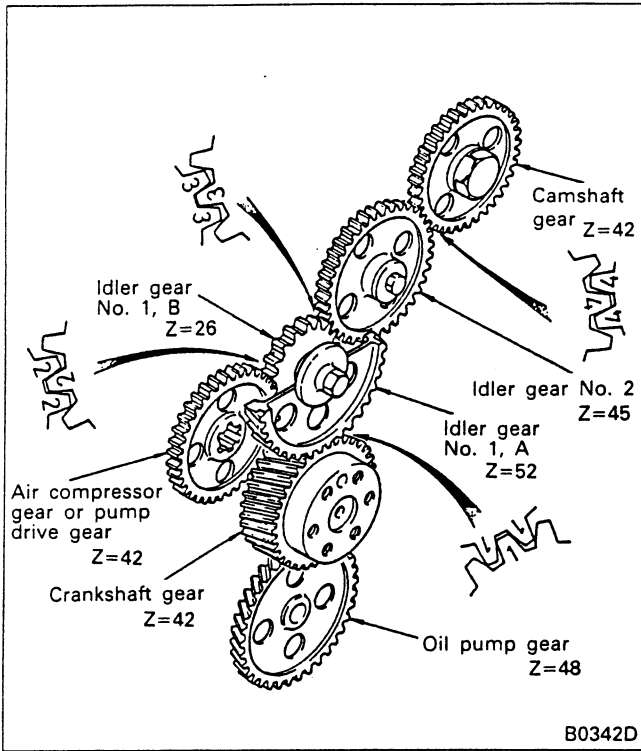

Timing gears are mounted in the rear of the engine and the gear train, as illustrated here. The crankshaft gear and idler gear drive the camshaft and air compressor (or pump drive). The crankshaft gear also drives the oil pump gear positioned under it. Each gear has a timing mark stamped on it. At the time of assembly, aligning these marks ensures correct meshing.

(8) Flywheel

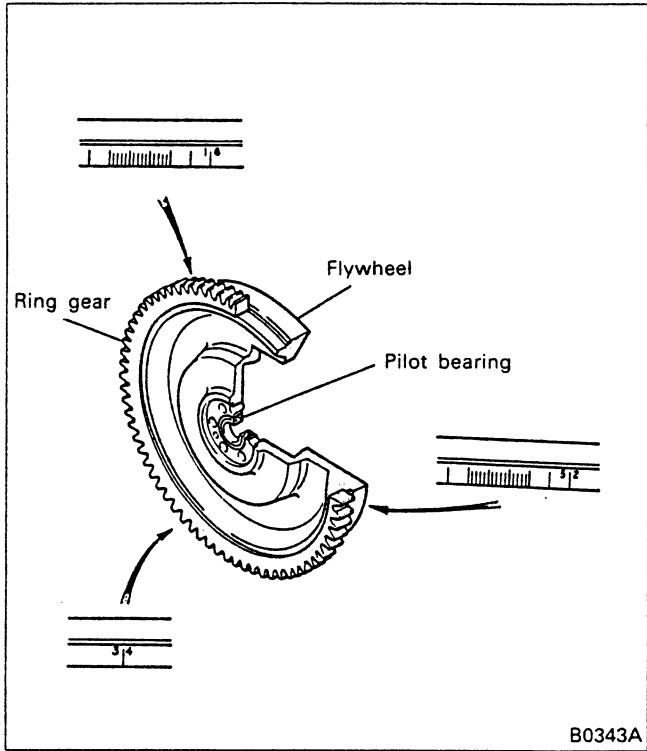

The flywheel is made of cast iron. The pilot bearing of the transmission drive pinion is installed at its center. On its periphery, the ring gear is shrink-fitted that meshes with the starter pinion. The ring gear tooth crests are induction-hardened for greater durability. At the same time, one side of the crests is chamfered to ensure that the starter pinion meshes easily when starter is operated. The cylinder numbers and angle scale are stamped on the outside periphery of the flywheel as shown in the figure.

1.2 Flywheel PTO

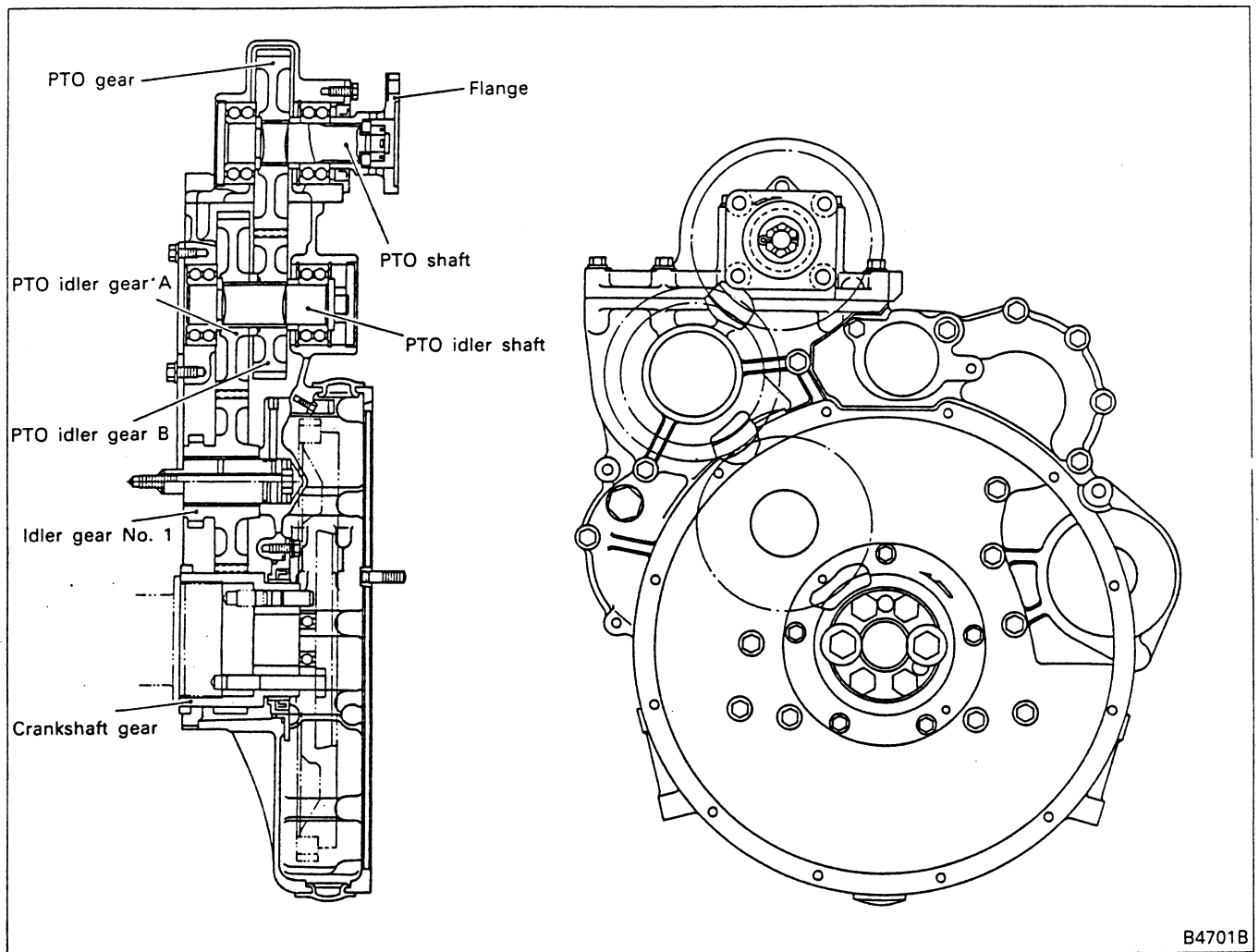

B4701B

The flywheel PTO is mounted on the top of the flywheel housing at the rear of the engine. Power is transmitted from the crankshaft gear to the idler gear No. 1, PTO idler gears A and B and then to the PTO gear and is outputted from the flange.

<https://www.ebooklibonline.com>

Hello dear friend!

Thank you very much for reading.

Enter the link into your browser.

The full manual is available for immediate download.

<https://www.ebooklibonline.com>