

**INDUSTRIAL
DIESEL ENGINE**

**AU-4LE2X
MODEL**

WORKSHOP MANUAL

ISUZU MOTORS LIMITED

07/12/05

General Information

General Information

Table of Contents

General Information	0A-2
Service Precautions	0A-2
Reading the Model	0A-7
General Information	0A-8
Recommended Lubricant	0A-14
List of Trouble Symptom	0A-15
Repair Standard	0A-24

General Information

Service Precautions

In order to carry out work safely

1. Always use an engine stand when taking the engine down from the vehicle.
Do not place the engine directly onto the ground, or place in a manner that interferes with the oil pan.
2. If you are working together with others, always pay attention to each other's safety.
3. If you are repairing any part of the electrical system, always remove the minus side cable from the battery terminal before starting work. If you are removing the battery cover, always remove the cover in a place that is away from sources of fire/heat.

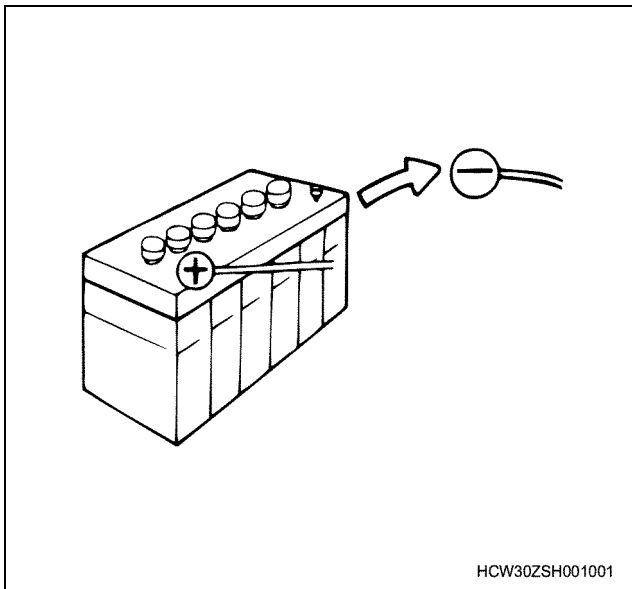

4. Do not perform painting work or leave the engine running for long periods of time in an enclosed or badly ventilated indoor workshop.

5. Always use the correct specialized tool indicated in the instructions. Using the incorrect tool may cause damage to the parts or injury to the person using the tool.

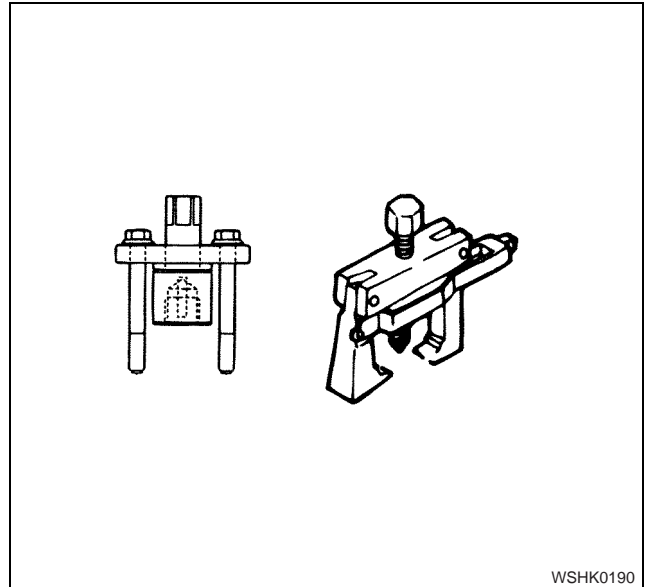

6. All regular tools, gauges and special tools should be regularly inspected, and prepared before starting work. Do not use bent spanners, hammers with damaged edges, chipped chisels, or any other faulty or damaged tools.

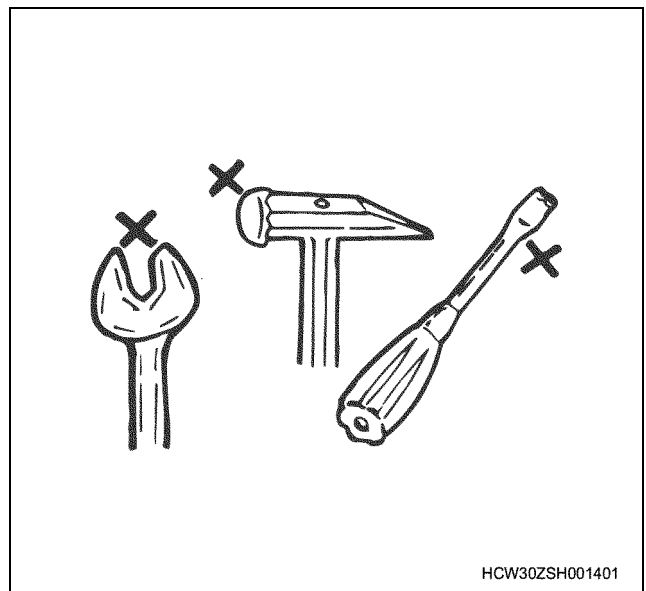

<https://www.ebooklibonline.com>

Hello dear friend!

Thank you very much for reading.

Enter the link into your browser.

The full manual is available for immediate download.

<https://www.ebooklibonline.com>

7. Always pay close attention to safety and handling requirements when using grinders, cranes, welders, and other such equipment. Moreover, always wear the correct protective garments and use the necessary safety tools for the job in hand.

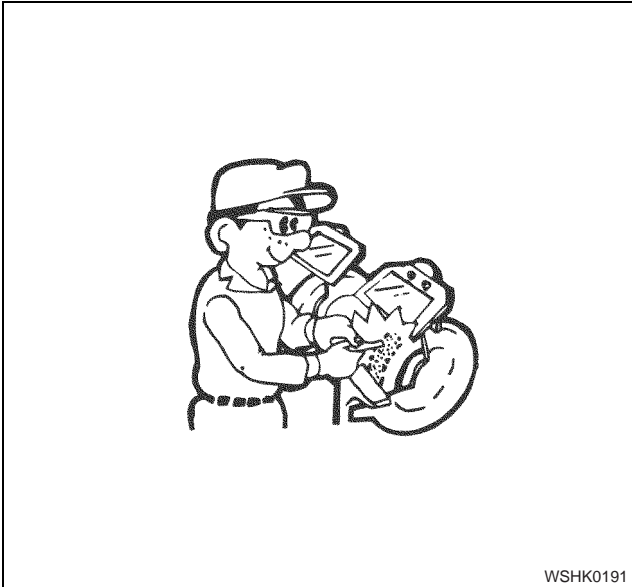

8. Always check that there are no fuel leaks when performing maintenance work on the fuel system. (It may cause a fire.)

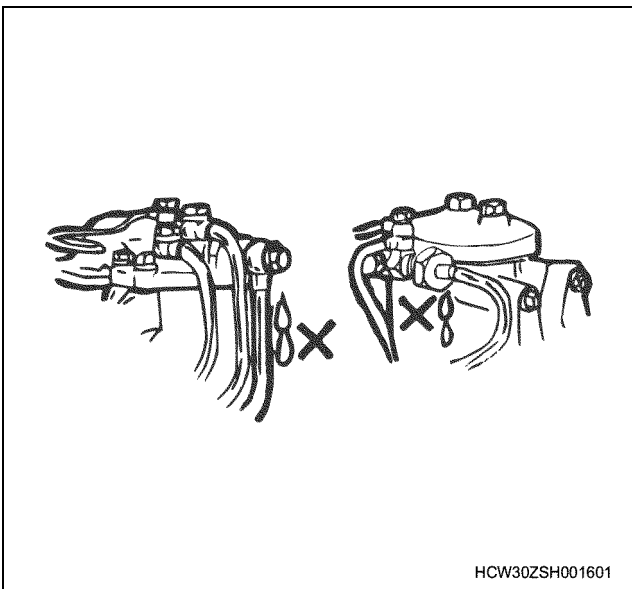

9. Pay close attention to the risk of ignition if you are handling parts that carry a high voltage. Furthermore, any oil or grease spilt onto rubber parts must be wiped off immediately, as it will cause deterioration of the rubber.



Replacement parts and part numbers

1. Always replace packing, oil seals, O-rings, caulking lock nuts, folding lock plates, split pins and other such parts with brand new parts.
2. The parts numbers contained in this manual may not represent the supply condition of the parts, and the part numbers may be changed due to revisions. Therefore, parts should always be checked against a parts catalogue before use.

0A-4 General Information

Liquid gasket

- Each time you disassemble parts that use liquid gasket, completely remove the old gasket residue from each of the parts and matching sections using a scraper, then clean each of the parts to completely remove oil, water, and dirt etc. from the various surfaces by a cloth. Using the specified type of liquid gasket, apply new liquid gasket to each of the surfaces before reassembling the parts.
- In order to make it easier to clean liquid gasket surfaces, apply gasket remover liquid (Pando- 391D made by ThreeBond Co., Ltd.) and leave the part to stand for approximately 10 minutes, after which the old liquid gasket residue will be easier to remove.
However, this should not be used on resin components or painted components.

- Please take care not to apply too much or too little liquid gasket.
Also, you should always re-apply the liquid gasket upon itself when you start and finish application.
- Make sure that there are no gaps when reinstalling the liquid gasket parts to each other. If there are gaps between the two parts, re-apply the liquid gasket. Some parts, especially the oil pan, use the same size studs as a guide to eliminate the need for knock pin positioning etc.
- Re-install these parts within 5 minutes of applying the liquid gasket.
If more than 5 minutes passes, remove the previous liquid gasket and re-apply it.
- Please wait for at least 30 minutes since the last part is installed before starting the engine.

Liquid gasket

	Applied area		Use conditions		Liquid gasket name
	Parts	Matching parts	Seal object	Application groove	
1	Rocker bracket	Cylinder head	Engine oil (10W — 30)	Equipped	TB 1207B
2	Air inlet pipe	Cylinder head cover	Air	Equipped	TB 1207C
3	Timing case	Cylinder block	Engine oil (10W — 30)	Equipped	TB 1207B
4	Housing cover; injection pump	Cylinder block	Engine oil (10W — 30)	None	TB 1207C
5	Solenoid; fuel cut	Cylinder block	Engine oil (10W — 30)	Equipped	TB 1207C
6	Retainer; oil seal	Cylinder block	Engine oil (10W — 30)	Equipped	TB 1207B
7	Housing ASM; PCV	Cylinder head cover	Blow-by gas	None	TB 1207C
8	Indicator; air cleaner	Air cleaner	Air	None	(Seal tape)

- Always use the liquid gasket products listed above, or a liquid gasket identical to the ones listed above.
- Use the correct quantity of liquid gasket. Always follow the handling instructions for each product.

Application procedure

1. Wipe the contact surfaces clean of all water, oil or grease. The contact surfaces should be dry.
2. Apply a regular bead width of liquid gasket to one of the contact surfaces. Make sure that the bead does not break at this point.

Note:

If there are special regulations concerning the application procedure in the repair document, please follow those regulations.

Work procedure

1. Wipe the joint surfaces of the bolt, bolt hole, and threads clean of water, grease, and oil. The contact surfaces should be dry.
2. Apply Loctite to the top 1/3 of the screw.
3. Tighten the bolt to the specified torque.

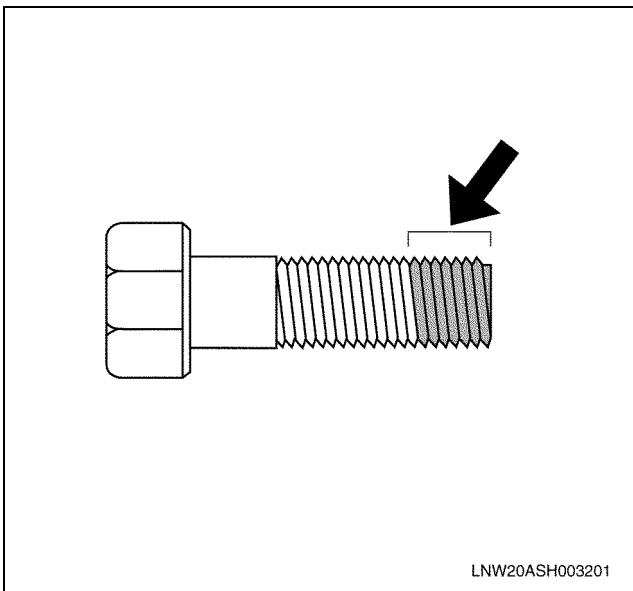

Important:

After tightening the bolt, do not apply excessive torque or try to rotate the bolt until at least one hour has passed, and the Loctite has hardened.

Procedure for using the plastigauge

Type	Measurable range mm {in}
PG-1 (Green)	0.025 — 0.076 {0.001 — 0.003}
PR-1 (Red)	0.051 — 0.152 {0.002 — 0.006}
PB-1 (Blue)	0.102 — 0.229 {0.004 — 0.009}

Example: Procedure for measuring the clearance between the connecting rod bearing and crank pin.

- Clean the connecting rod and bearing, and install the bearing to the rod.
- Cut the plastigauge to the same width as the crank pin, and while avoiding the oil hole of the crank pin lay the gauge parallel to the pin.
- Line up the marks on the connecting rod and cap, and install the crank pin. Apply molybdenum disulfide to the thread section and seating surface of the tightening bolt, and rotate both cap and bolt to the correct torque.

Important:

Do not move the connecting rod while using the plastigauge.

- Gently remove the cap and connecting rod, and measure the crushed width of the plastigauge (clearance between rod and pin) using the scale printed on the bag.

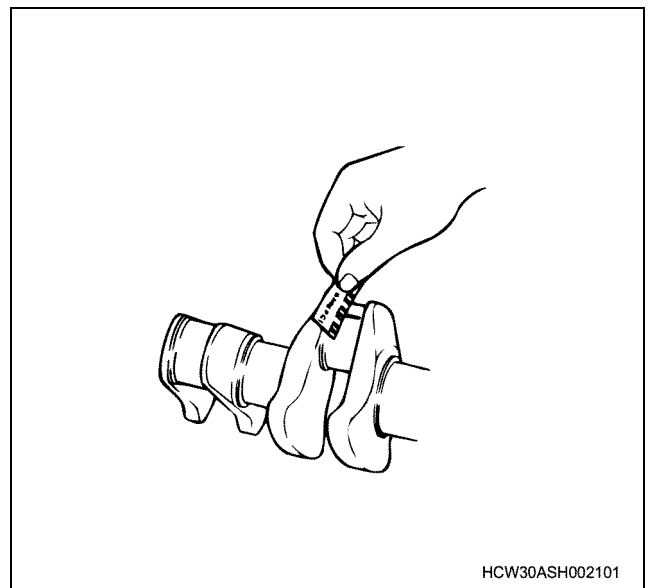
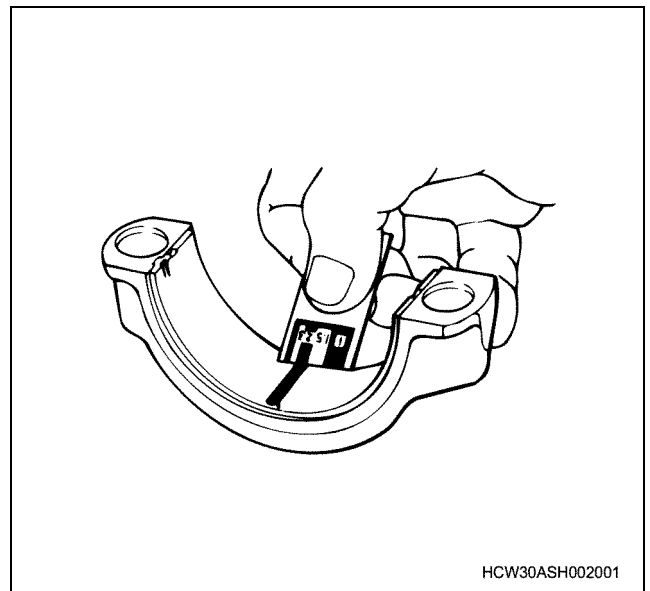

0A-6 General Information

Example: Measuring the clearance between the crank bearing and crank journal

- Clean the clamp face of the cylinder block and crankcase bearing, and also the bearing, and install the cylinder block to the crankcase.
- Gently rest the crankshaft on the cylinder block, and rotate it approximately 30 degree to stabilize it.
- Cut the plastigauge to the same size as the journal width, and while avoiding the oil hole of the journal lay the gauge parallel to the journal.
- Gently rest the crankcase on the cylinder block, apply molybdenum disulfide to the thread section and seating surface of the tightening bolt, and tighten in sequence to the correct torque.

Important:

Do not rotate the crankshaft while using the plastigauge.

- Gently remove the crankcase, and measure the crushed width of the plastigauge (clearance between bearing and journal) using the scale printed on the bag.

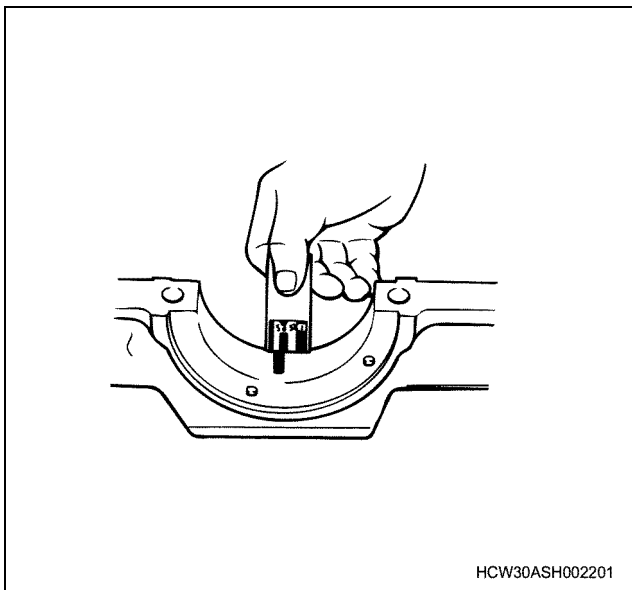
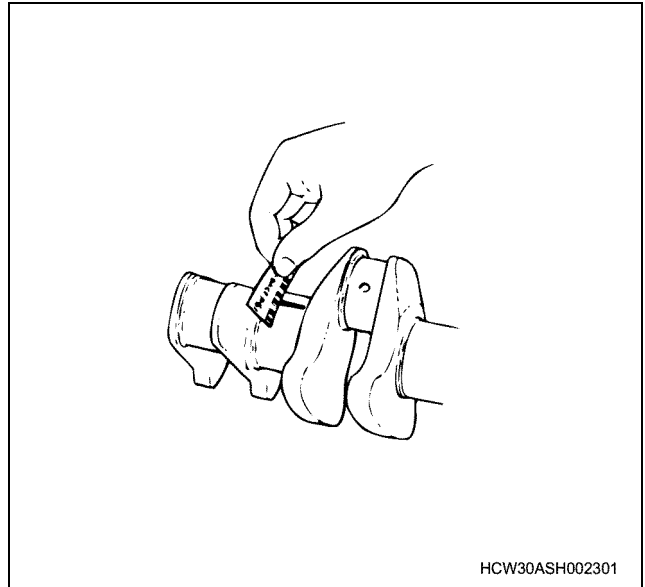

Reading the Model

Engine number stamping position

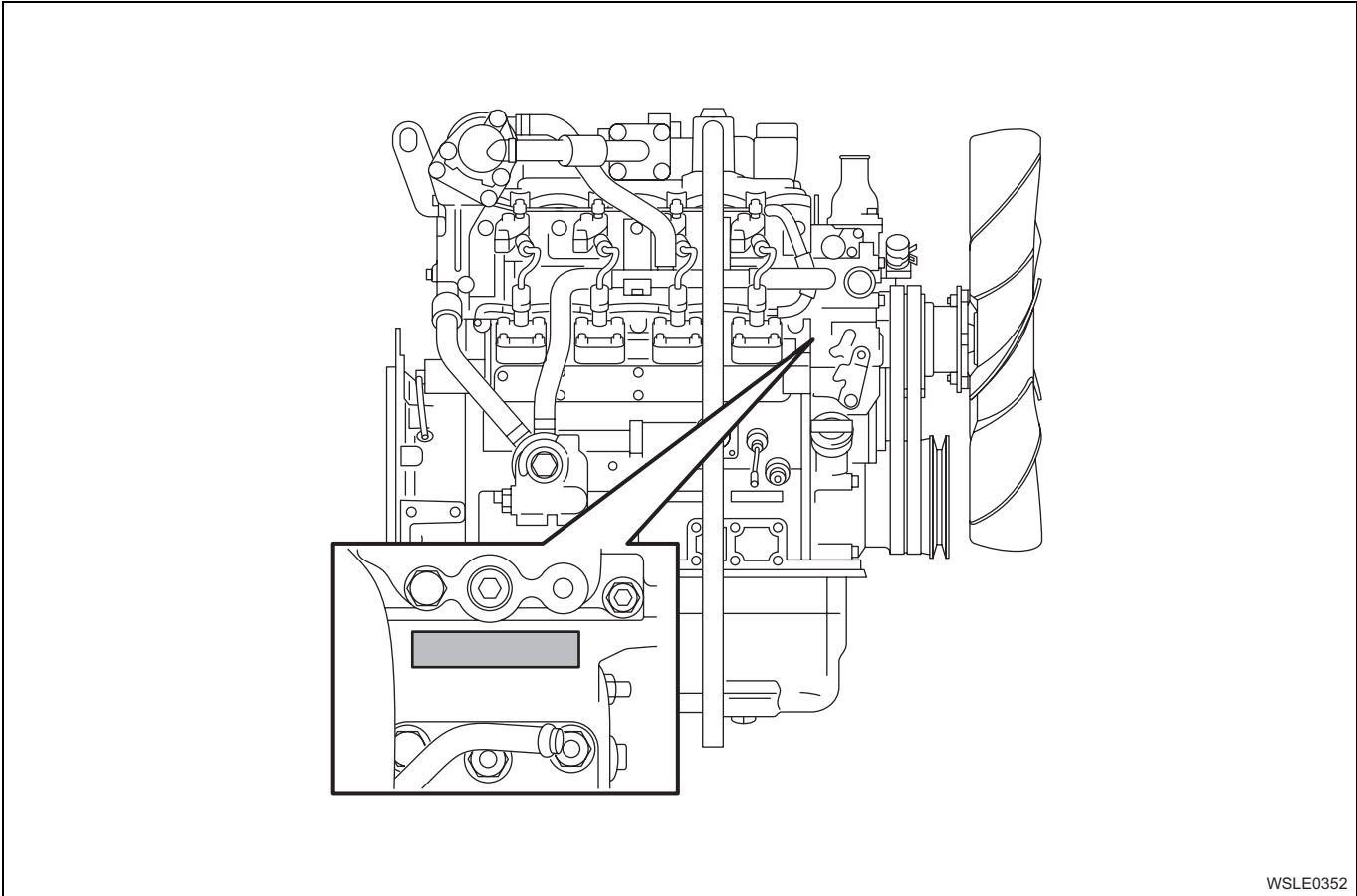

General Information

Terminology, description of abbreviations

Terminology definitions

Maintenance standard

The generic name for reference values required for maintenance, such as nominal dimension, assembly specification, and limit.

Nominal dimension

Shows the standard value at the point of manufacture that does not include the common difference.

Assembly specification

Shows the standard value after assembling, repairing, or adjusting.

Service limit

When this value (dimensions) is reached, it shows that the part has reached its full limit and must be replaced or repaired.

Wear

Shows the difference between the dimension of non-worn part (nominal dimension unless there is such part) and that of the most worn part (the dimension of worn part).

Uneven wear

Shows the difference between the maximum and the minimum wear amount.

Front/Rear, Right/Left, Top/Bottom

These show each orientations of parts installed to the vehicle when looking from the vehicle's forward direction.

Unit

Units written to SI conventions (mainly torque, pressure, force)

[Example] Length: mm, Torque: N·m {kgf·m}

Warning

Items that carry the warning mark pose a danger to life or threat of serious injury if not strictly observed.

Caution

Items that carry the caution mark may cause injury or lead to accidents if not strictly observed.

Important

Items that carry the important mark may cause the vehicle to break down, or may prevent the guaranteed normal operation of the system or related parts if not strictly observed.

Note

Items that should receive special mention within a work procedure.

Description of abbreviations

Abbreviation	Description
AC	Alternating Current
ACC	Accessory
ACG	Alternating Current Generator
API	American Petrol Institute
ASM (Assy)	Assembly
ATDC	After Top Dead Center
BAT, BATT	Battery
BRG, Brg	Bearing
BKT, BRKT	Bracket
BTDC	Before Top Dead Center
CO	Carbon Oxide
CONN	Connector
CPU	Central Processing Unit
C/U	Control Unit
DC	Direct Current
DI	Direct Injection
ECU	Engine Control Unit/Electronic Control Unit
ECM	Engine Control Module
EGR	Exhaust Gas Recirculation
Exh, EXH	Exhaust
Ft, FRT	Front
FWD	Forward
F/C	Fuel Cut
GND	Ground
IC	Integrated Circuit
ID Plate	Identification Plate
IN	Intake, Inlet
ISO	International Organization for Standardization
I/PUMP	Injection Pump
JIS	Japanese Industrial Standard
L/H, LH	Left Hand
M/V	Magnetic Valve
NOx	Nitrogen Oxide
N-TDC	Number - Top Dead Center
OPT	Option
P	Pole(S)
PCV	Pump Control Valve/Positive Crankcase Ventilation

Abbreviation	Description
PM	Particulate Matter
PS	Pre-Stroke
PTO	Power Take Off
QOS	Quick On System
Rr, RR	Rear
R/H, RH	Right Hand
R/L	Relay
STD	Standard
SW	Switch
TICS	Timing & Injection rate Control System
VGS Turbo	Variable Geometry turbocharger System
W/L	Warning Lamp

SI (International System of Units)

With regards the conversion to SI (International System of Units)

The introduction of the SI systems aims to internationally unify the metric system and the various units used by different countries (traditional weights and measures, the foot pound method etc.), and to curb the confusion that occurs between the different units (conversion calculations etc.).

The new calculating method which adopted SI units was completely adopted in Japan in 1992, and is standardized by JIS-Z-8203.

All of the units in this manual are written in line with the International System of Units SI units, and conventional units are written in { } brackets.

SI

Abbreviation of French word "Le Systeme International d'Unites"

Connection between main SI units and conventional units

	SI	Conventional unit	Item, unit conversion
Length	m	m	Same as the conventional unit
Weight (Mass)	kg	kg	Same as the conventional unit
Force	N	* kg, kgf	1 kgf = 9.80665 N
Torque	N·m	* kg·m, kgf·m	1 kgf·m = 9.80665 N·m
Pressure	Pa	* kg/cm ² , mmHg	1 kgf/cm ² = 9.80665 kPa, 1 mmHg = 133.3 Pa
Power output, horsepower	W	PS	1 PS = 0.74 kW
Capacity, air volume displacement	m ³	Liter, L, cc	1 Liter = 1 dm ³ , 1 cc = 1 m Liter = 1 cm ³
Fuel consumption	g/(kW·h)	g/(PS·h)	1 g/(PS·h) = 1.360 g/(kW·h)

*1 Published service data may conveniently use kg for force and mass (weight) instead of kgf.

*2 Some conversion results may be rounded off to 1 or 2 decimal places.

Converting expressions of quantity

When converting, prefixes such as k (kilo) or m (milli) are used.

M	Mega	10 ⁶	1,000,000
k	Kilo	10 ³	1,000
h	Hecto	10 ²	100
d	Deci	10 ⁻¹	0.1
c	Centi	10 ⁻²	0.01
m	Milli	10 ⁻³	0.001
μ	Micro	10 ⁻⁶	0.000001

- 200 kgf/cm² = 19,620 kPa = 19.6 MPa
- 40 mmHg = 5,332 Pa = 5.3 kPa

Conversion formula

Length

- km × 0.6214 = mile
- m × 3.281 = ft
- mm × 0.03937 = in

Pressure

- kPa × 0.0101972 = kg/cm²
- kPa × 0.145038 = psi
- MPa × 10.197162 = kg/cm²
- MPa × 145.03774 = psi

Tightening torque

- N·m × 0.101972 = kg·m
- N·m × 0.737562 = lb·ft

Speed

- km/h × 0.6214 = MPH

Temperature

- °C × 1.8 + 32 = °F

0A-10 General Information

Table of Isuzu standard tightening torque

The tightening torque values in the table below apply to all situations unless a special tightening torque is specified.

Isuzu standard bolts, nuts

N·m {kgf·m}				
Strength classification	4.8 4T		7T	
Shape of bolt head	Hexagon head bolt	Flange bolt	Hexagon head bolt	Flange bolt
*M10 × 1.5	19.6 — 33.3 {2.0 — 3.4}	22.3 — 37.2 {2.3 — 3.8}	27.5 — 45.1 {2.8 — 4.6}	30.3 — 50.4 {3.1 — 5.1}
M12 × 1.25	49.0 — 73.5 {5.0 — 7.5}	54.9 — 82.3 {5.6 — 8.4}	60.8 — 91.2 {6.2 — 9.3}	68.1 — 102.1 {6.9 — 10.4}
*M12 × 1.75	45.1 — 68.6 {4.6 — 7.0}	51.0 — 76.5 {5.2 — 7.8}	56.9 — 84.3 {5.8 — 8.6}	62.7 — 94.0 {6.4 — 9.6}
M14 × 1.5	76.5 — 114.7 {7.8 — 11.7}	83.0 — 124.5 {8.5 — 12.7}	93.2 — 139.3 {9.5 — 14.2}	100.8 — 151.1 {10.3 — 15.4}
*M14 × 2	71.6 — 106.9 {7.3 — 10.9}	77.2 — 115.8 {7.9 — 11.8}	88.3 — 131.4 {9.0 — 13.4}	94.9 — 142.3 {9.7 — 14.5}
M16 × 1.5	104.0 — 157.0 {10.6 — 16.0}	115.6 — 173.3 {11.8 — 17.7}	135.3 — 204.0 {13.8 — 20.8}	150.1 — 225.2 {15.3 — 23.0}
*M16 × 2	100.0 — 149.1 {10.2 — 15.2}	109.4 — 164.2 {11.2 — 16.7}	129.4 — 194.2 {13.2 — 19.8}	142.5 — 213.8 {14.5 — 21.8}
M18 × 1.5	151.0 — 225.6 {15.4 — 23.0}	—	195.2 — 293.2 {19.9 — 29.9}	—
*M18 × 2.5	151.0 — 225.6 {15.4 — 23.0}	—	196.1 — 294.2 {20.0 — 30.0}	—
M20 × 1.5	206.0 — 310.0 {21.0 — 31.6}	—	269.7 — 405.0 {27.5 — 41.3}	—
*M20 × 2.5	190.2 — 286.4 {19.4 — 29.2}	—	249.1 — 374.6 {25.4 — 38.2}	—
M22 × 1.5	251.1 — 413.8 {25.6 — 42.2}	—	362.8 — 544.3 {37.0 — 55.5}	—
*M22 × 2.5	217.7 — 327.5 {22.2 — 33.4}	—	338.3 — 507.0 {34.5 — 51.7}	—
M24 × 2	358.9 — 539.4 {36.6 — 55.0}	—	430.5 — 711.0 {43.9 — 72.5}	—
*M24 × 3	338.3 — 507.0 {34.5 — 51.7}	—	406.0 — 608.0 {41.4 — 62.0}	—

The * mark indicates where soft materials have been used for internal thread sections, such as castings.

N·m {kgf·m}				
Strength classification	8.8		9.8 9T	
Shape of bolt head	Hexagon head bolt	Flange bolt	Hexagon head bolt	Flange bolt
M6 × 1	5.6 — 11.2 {0.6 — 1.1}	6.6 — 12.2 {0.6 — 1.2}	—	—
M8 × 1.25	13.4 — 25.7 {1.4 — 2.6}	15.3 — 28.4 {1.6 — 2.9}	16.7 — 30.4 {1.7 — 3.1}	18.1 — 33.6 {1.9 — 3.4}
M10 × 1.25	31.3 — 52.5 {3.2 — 5.4}	35.4 — 58.9 {3.6 — 6.1}	37.3 — 62.8 {3.8 — 6.4}	42.3 — 70.5 {4.3 — 7.2}
*M10 × 1.5	31.3 — 51.4 {3.2 — 5.2}	34.5 — 57.5 {3.5 — 5.8}	36.3 — 59.8 {3.7 — 6.1}	40.1 — 66.9 {4.1 — 6.8}
M12 × 1.25	69.3 — 104.0 {7.1 — 10.6}	77.7 — 116.5 {7.9 — 11.9}	75.5 — 113.8 {7.7 — 11.6}	85.0 — 127.5 {8.7 — 13.0}
*M12 × 1.75	64.8 — 96.1 {6.6 — 9.8}	71.4 — 107.2 {7.3 — 10.9}	71.6 — 106.9 {7.3 — 10.9}	79.5 — 119.2 {8.1 — 12.2}
M14 × 1.5	106.2 — 158.8 {10.8 — 16.2}	114.9 — 172.3 {11.7 — 17.6}	113.8 — 170.6 {11.6 — 17.4}	123.4 — 185.1 {12.6 — 18.9}
*M14 × 2	100.6 — 149.8 {10.3 — 15.3}	108.2 — 162.2 {11.1 — 16.6}	106.9 — 160.0 {10.9 — 16.3}	115.5 — 173.3 {11.8 — 17.7}
M16 × 1.5	154.3 — 232.5 {15.7 — 23.7}	171.1 — 256.7 {17.4 — 26.2}	160.0 — 240.3 {16.3 — 24.5}	176.9 — 265.3 {18.0 — 27.1}
*M16 × 2	147.6 — 221.4 {15.0 — 22.6}	162.5 — 243.8 {16.6 — 24.9}	153.0 — 229.5 {15.6 — 23.4}	168.5 — 252.7 {17.2 — 25.8}
M18 × 1.5	222.5 — 334.3 {22.7 — 34.1}	—	229.5 — 345.2 {23.4 — 35.2}	—
*M18 × 2.5	223.6 — 335.4 {22.8 — 34.2}	—	230.5 — 346.2 {23.6 — 35.3}	—
M20 × 1.5	307.4 — 461.7 {31.4 — 47.1}	—	316.8 — 475.6 {32.3 — 48.5}	—
*M20 × 2.5	284.0 — 472.1 {29.0 — 43.5}	—	293.2 — 440.3 {29.2 — 44.9}	—
M22 × 1.5	413.6 — 620.5 {42.2 — 63.3}	—	424.6 — 636.5 {43.3 — 64.9}	—
*M22 × 2.5	385.7 — 578.0 {39.3 — 58.9}	—	394.2 — 592.3 {40.0 — 60.4}	—
M24 × 2	490.8 — 810.5 {50.0 — 82.7}	—	554.1 — 830.6 {56.5 — 84.7}	—
*M24 × 3	462.8 — 693.1 {47.2 — 70.7}	—	520.7 — 781.6 {53.1 — 79.7}	—

The * mark indicates where soft materials have been used for internal thread sections, such as castings.

0A-12 General Information

Designations for Isuzu standard bolt heads

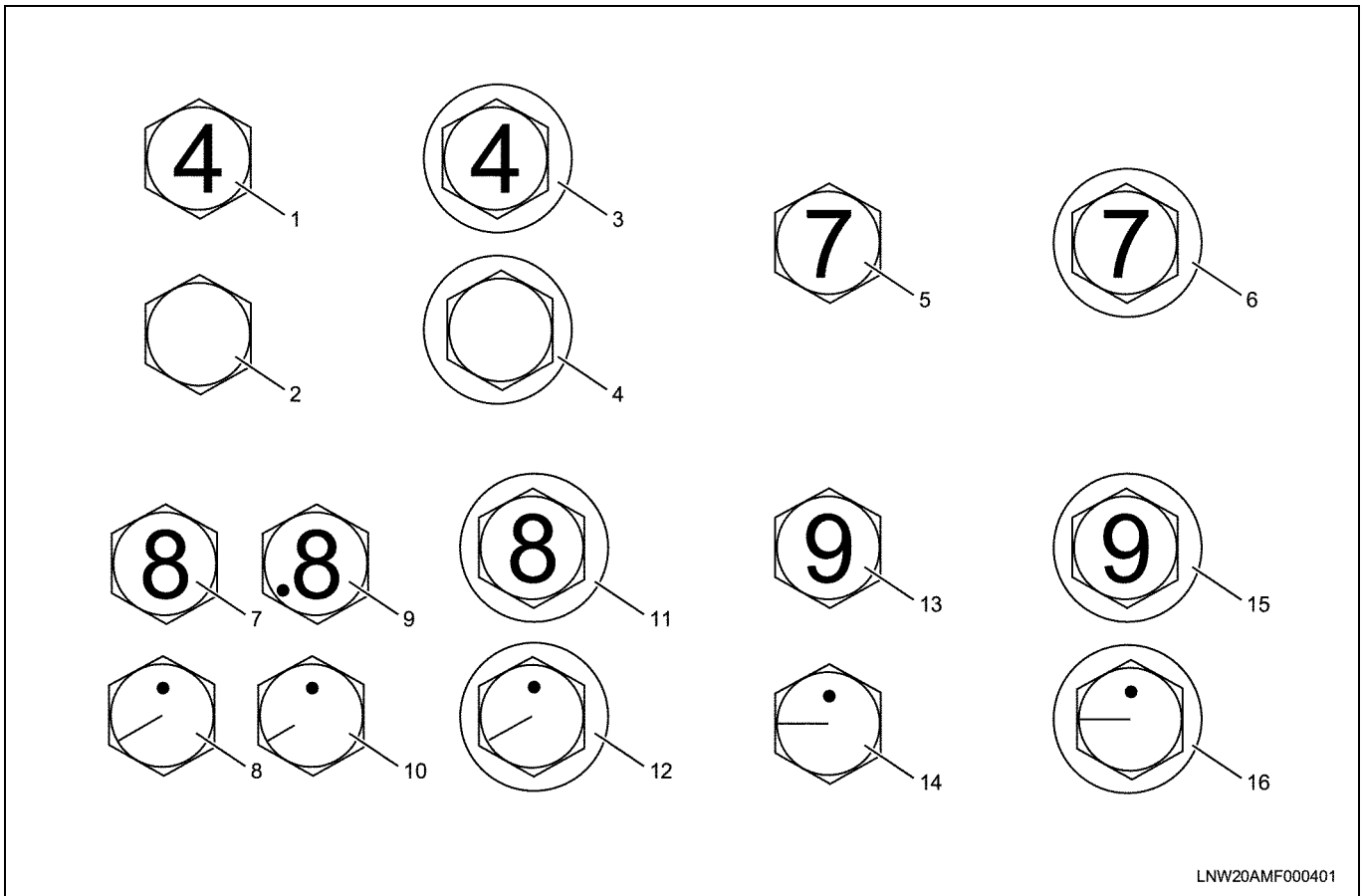

LNW20AMF000401

Name

- | | |
|--|--|
| 1. Hexagon Head Bolt (4.8, 4T) | 9. Hexagon Head Bolt (Nonthermal Refined 8.8) |
| 2. Hexagon Head Bolt (4.8, 4T) | 10. Hexagon Head Bolt (Nonthermal Refined 8.8) |
| 3. Flange Bolt (4.8, 4T) | 11. Flange Bolt (8.8) |
| 4. Flange Bolt (4.8, 4T) | 12. Flange Bolt (8.8) |
| 5. Hexagon Head Bolt (7T) | 13. Hexagon Head Bolt (9.8, 9T) |
| 6. Flange Bolt (7T) | 14. Hexagon Head Bolt (9.8, 9T) |
| 7. Hexagon Head Bolt (Thermal Refined 8.8) | 15. Flange Bolt (9.8, 9T) |
| 8. Hexagon Head Bolt (Thermal Refined 8.8) | 16. Flange Bolt (9.8, 9T) |

Flare nut

	Pipe diameter	Tightening torque (for medium and large size vehicles)	Width across flats of flare nut (mm)	
			Old	New
Flare nut tightening torque (service standard value) N·m {kgf·m}	φ 4.76 mm	12.8 — 18.6 {1.3 — 1.9}	14	14
	φ 6.35 mm	23.5 — 49 {2.4 — 5.0}	17	17
	φ 8.0 mm	23.5 — 49 {2.4 — 5.0}	19	17
	φ 10.0 mm	44.1 — 93.2 {4.5 — 9.5}	22	19
	φ 12.0 mm	58.8 — 137.3 {6.0 — 14.0}	27	24
	φ 15.0 mm	78.5 — 156.9 {8.0 — 16.0}	30	30

Taper screw from connectors (brass)

N·m {kgf·m}				
Screw size	PT (R) 1/8	PT (R) 1/4	PT (R) 3/8	PT (R) 1/2
—	2.0 — 14.7 {0.2 — 1.5}	4.9 — 15.7 {0.5 — 1.6}	9.8 — 16.7 {1.0 — 1.7}	9.8 — 17.7 {1.0 — 1.8}

About angle method tightening

Though the general and current way to tighten bolts and nuts is torque indication, using this way results in large unevenness of shaft power to indicated torque. Therefore, bolts may be damaged at upper limit when you try to ensure minimal shaft power.

To ensure shaft power with small unevenness, it is necessary to tighten bolts measuring stretch amount of bolts, but this is actually impossible. So the angle method focuses on screw pitch as equivalent to bolt stretch, and controls using the screw rotation amount. The method can reduce the unevenness of shaft power by tightening to plastic range.

How to tighten

1. Apply molybdenum disulfide or engine oil to the threads and the seating surface of the bolt following the instruction.
2. Tighten all bolts to the pre-indicated tightening torque.
3. Draw lines on the surface of the parts you tighten: the lines which pass through the bolt's center (A — B: bolt side) (C — D: parts side) and the line at the specified tightening angle from the bolt's center (E — F).

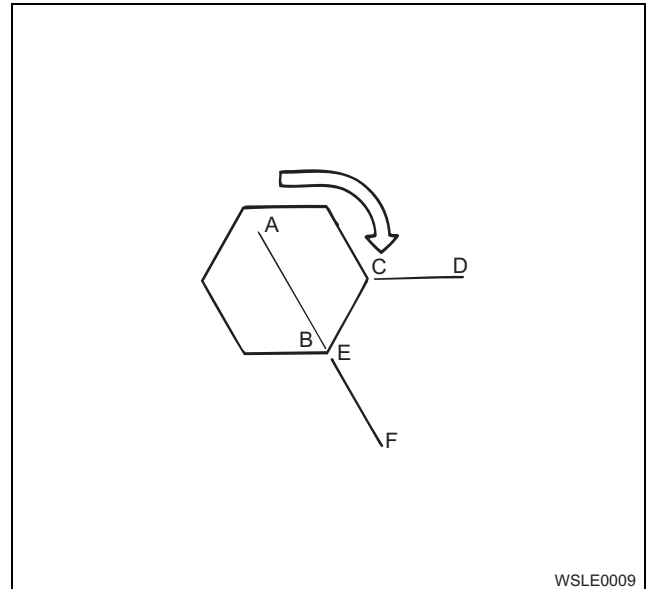

Be sure to check the mark to see whether you tighten the bolt to the specified angle or not. If you fail this, you may tighten the bolt by the angle method again by accident and damage the bolt. Take extreme care.

Important:

- Follow the instructed order to tighten bolts.
- Do not retighten if you tighten by the angle method.

Bolt angle gauge (5-8840-0266-0), the tool for tightening bolts by the angle method, is set.

Special tool classification

A; Essential tool

Servicing operation cannot be done with any other tools than the essential tool.

B; Recommend tool

Servicing work can be done with a general-purpose tool commercially available. However, it is advisable to use the recommended tool as much as possible for a reduced work time and an improved safety in work operations.

C; Available tool

Although it takes a more working time, servicing operations can be made with a tool commercially available as substitute for the available tool.

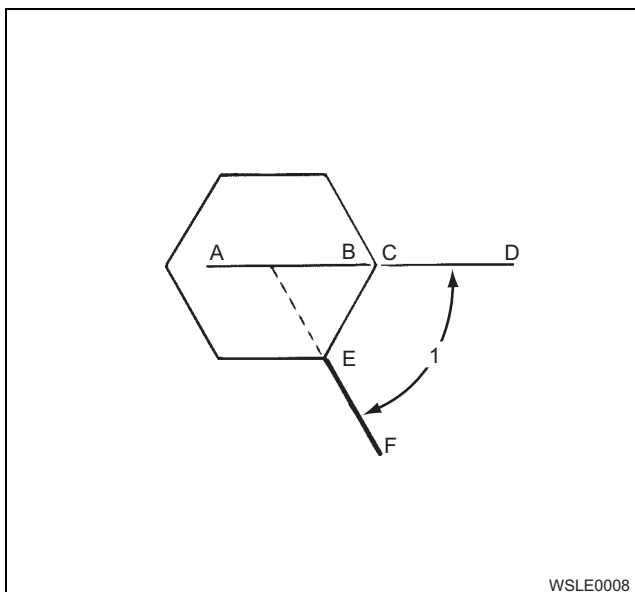

Name

1. Specified Tightening Torque

4. Tighten the bolt with wrench until the line on the bolt (A — B) aligns with the specified angle line (E — F on the surface of the parts).

0A-14 General Information

Recommended Lubricant

Engine oil

Use the engine oil below.

Engine oil grade

Engine classification	Engine oil grade (API service category)
With turbocharger	CD or CF-4 * (CE, CF, CH-4, CI-4 or CI-4 Plus)

* mark may vary depending on each machine. Refer to the machine manufacturer specification.

ISUZU genuine engine oil

Besco Super: CC

Besco S — 3: CD

Besco Multi Z: CD

Engine oil viscosity chart

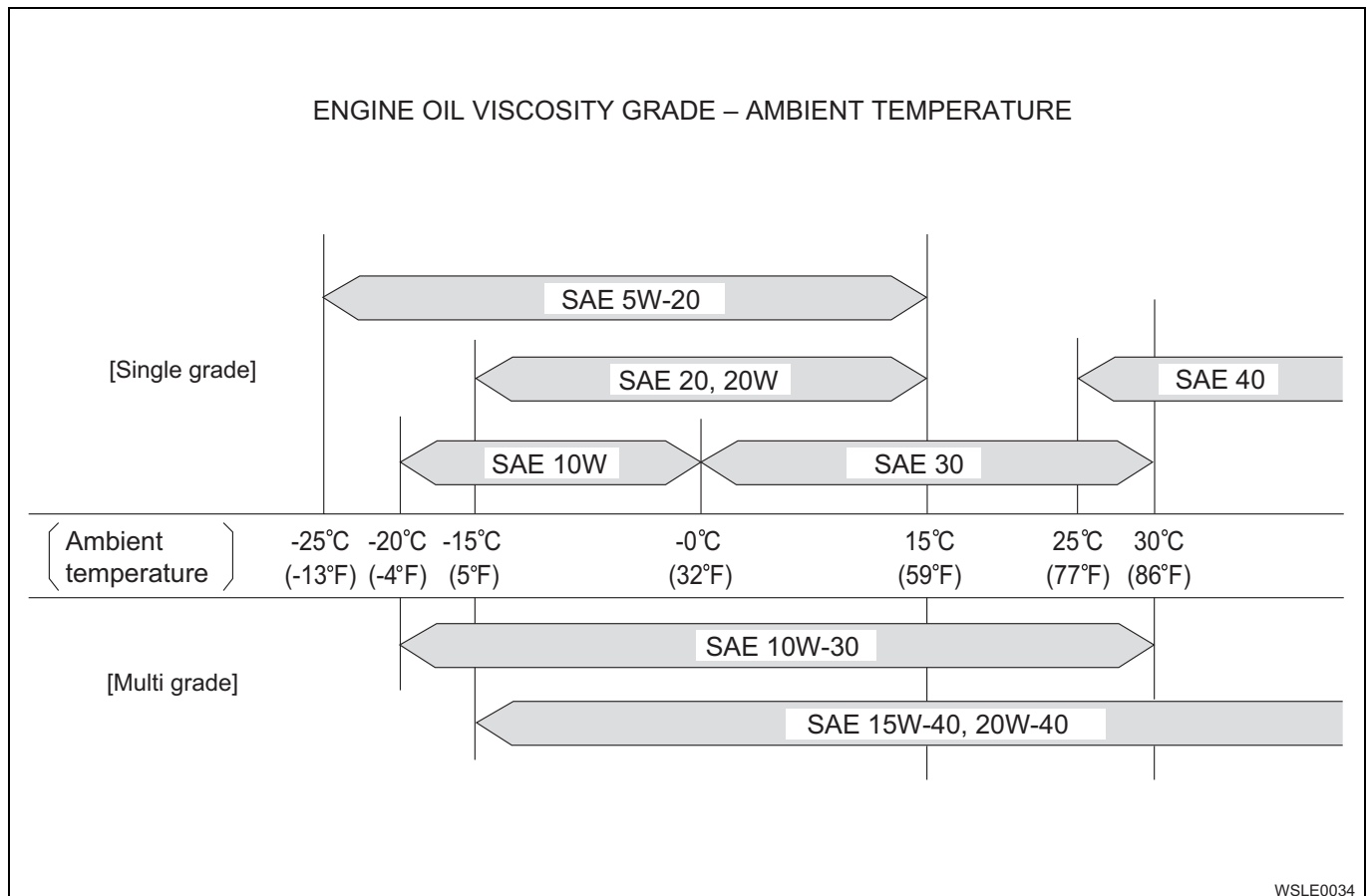

The engine oil affects the startability, driving performance, oil consumption, wear of the sliding part, and seizure, depending on the viscosity. You should select the engine oil depending to a temperature and the chart above.

Engine oil level

4LE2X model: Approx. 9.3 — 12.1 L {9.8 — 12.8 qts}

Note:

Engine oil level may vary depending on the machine specification.

Engine speed lacks smoothness

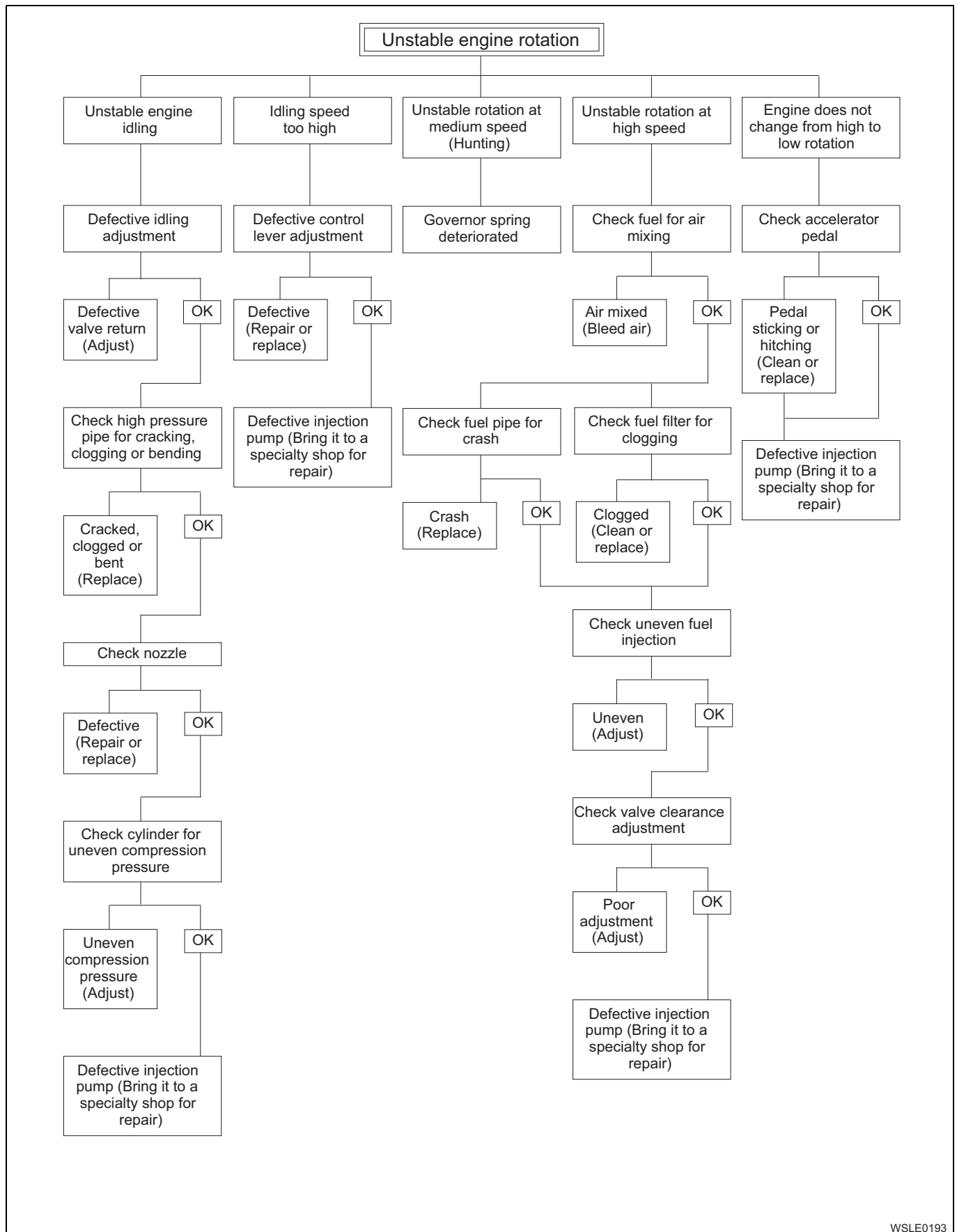

Output shortage

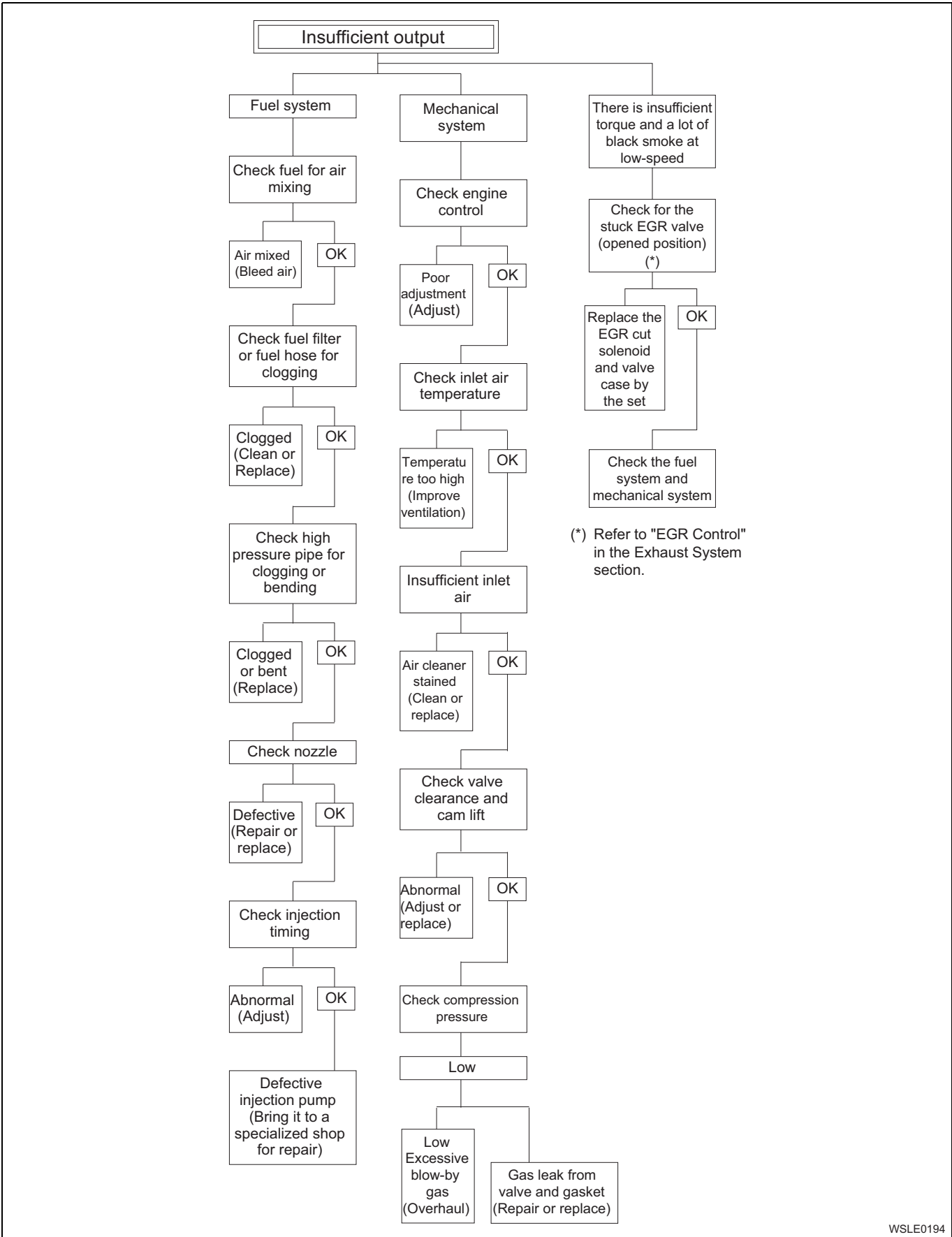

Overheat

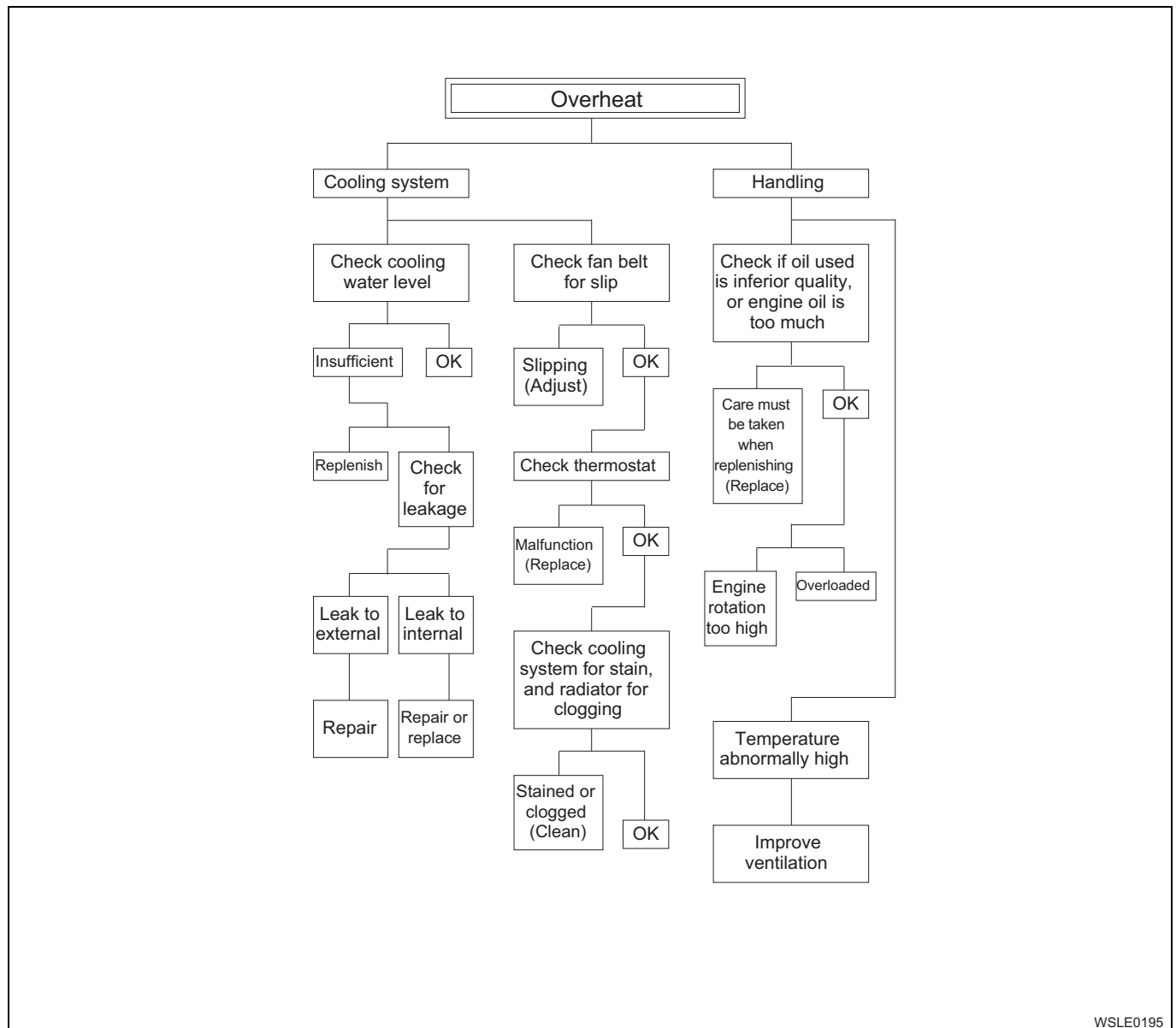

Exhaust fault

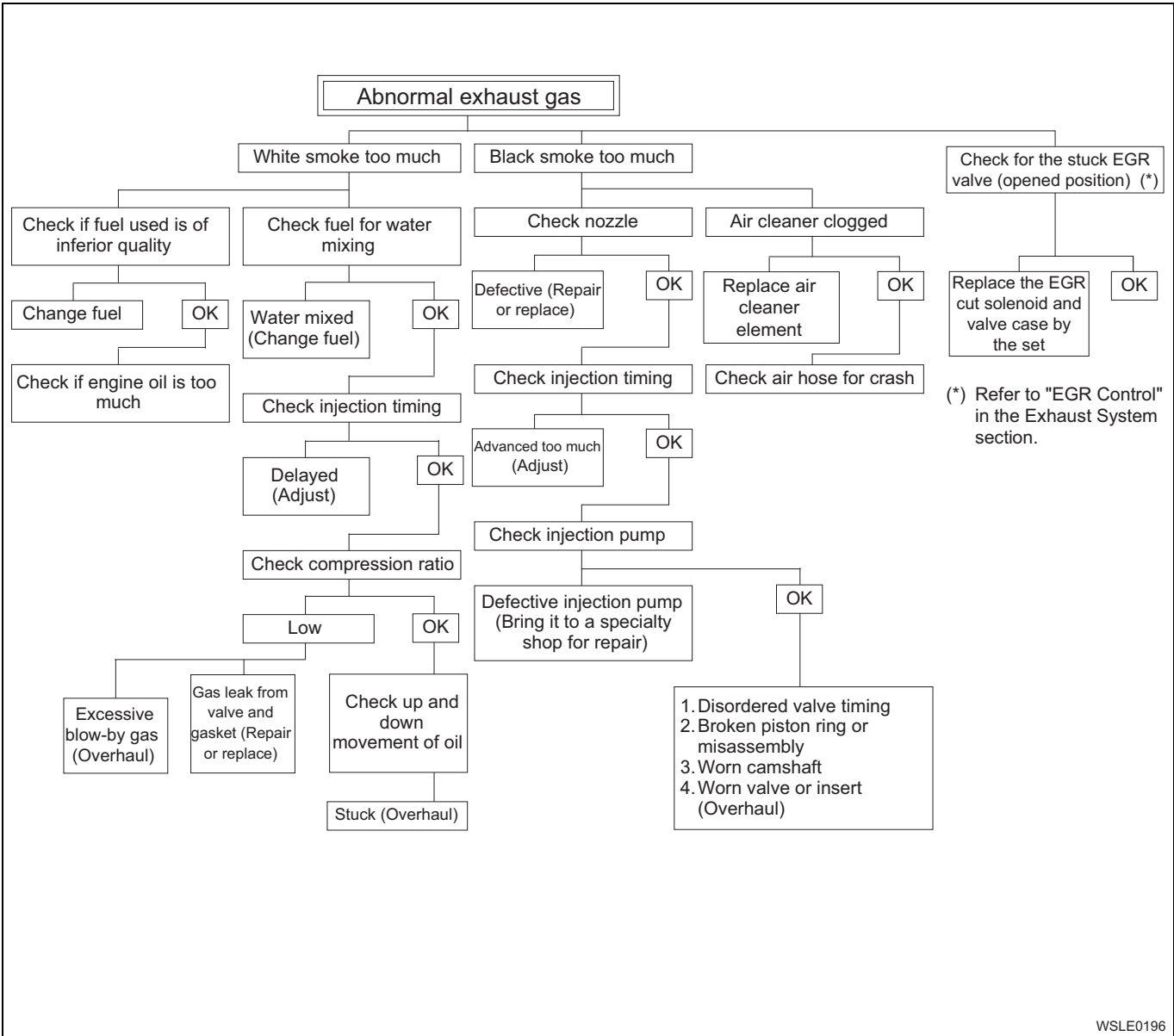

Battery over discharge

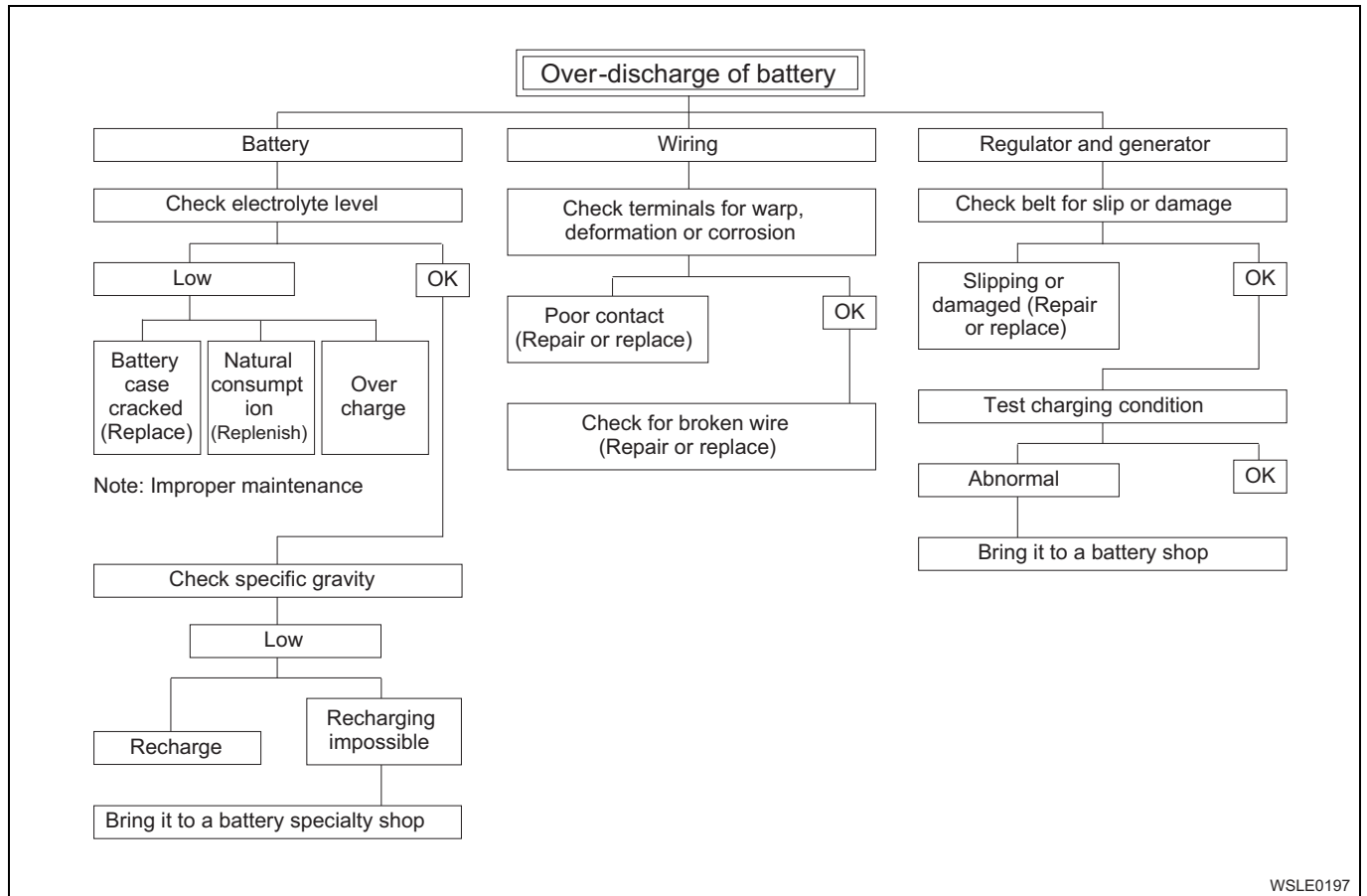

Oil pressure is too low

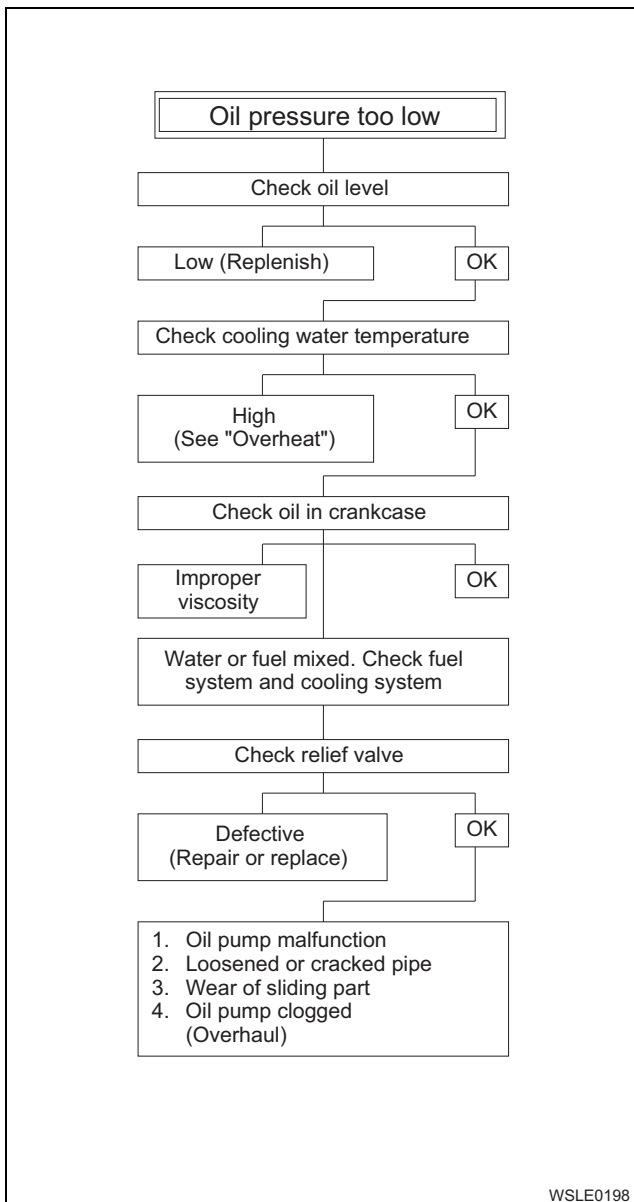

Fuel consumption deteriorates

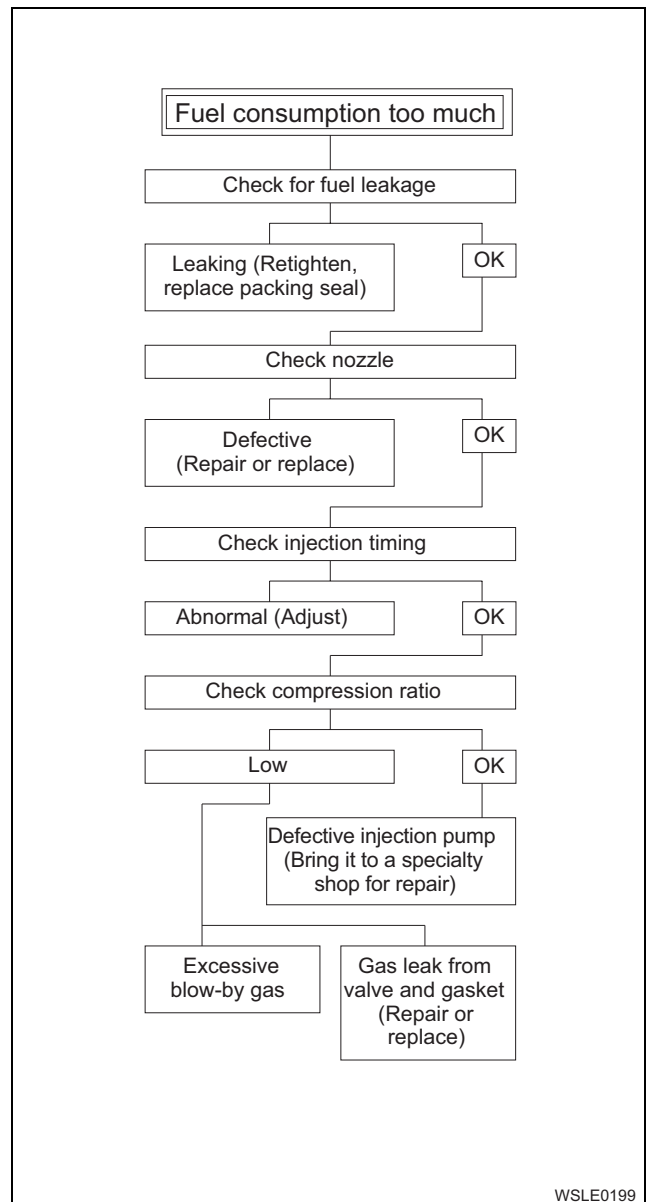

Oil consumption deteriorates

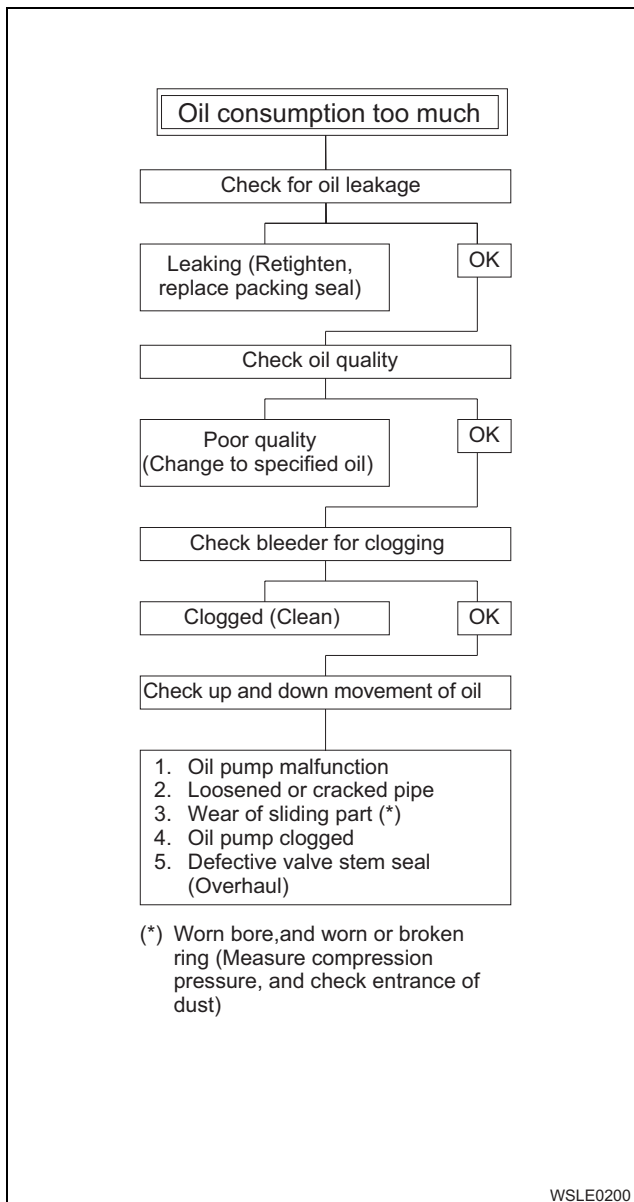

Engine knocking

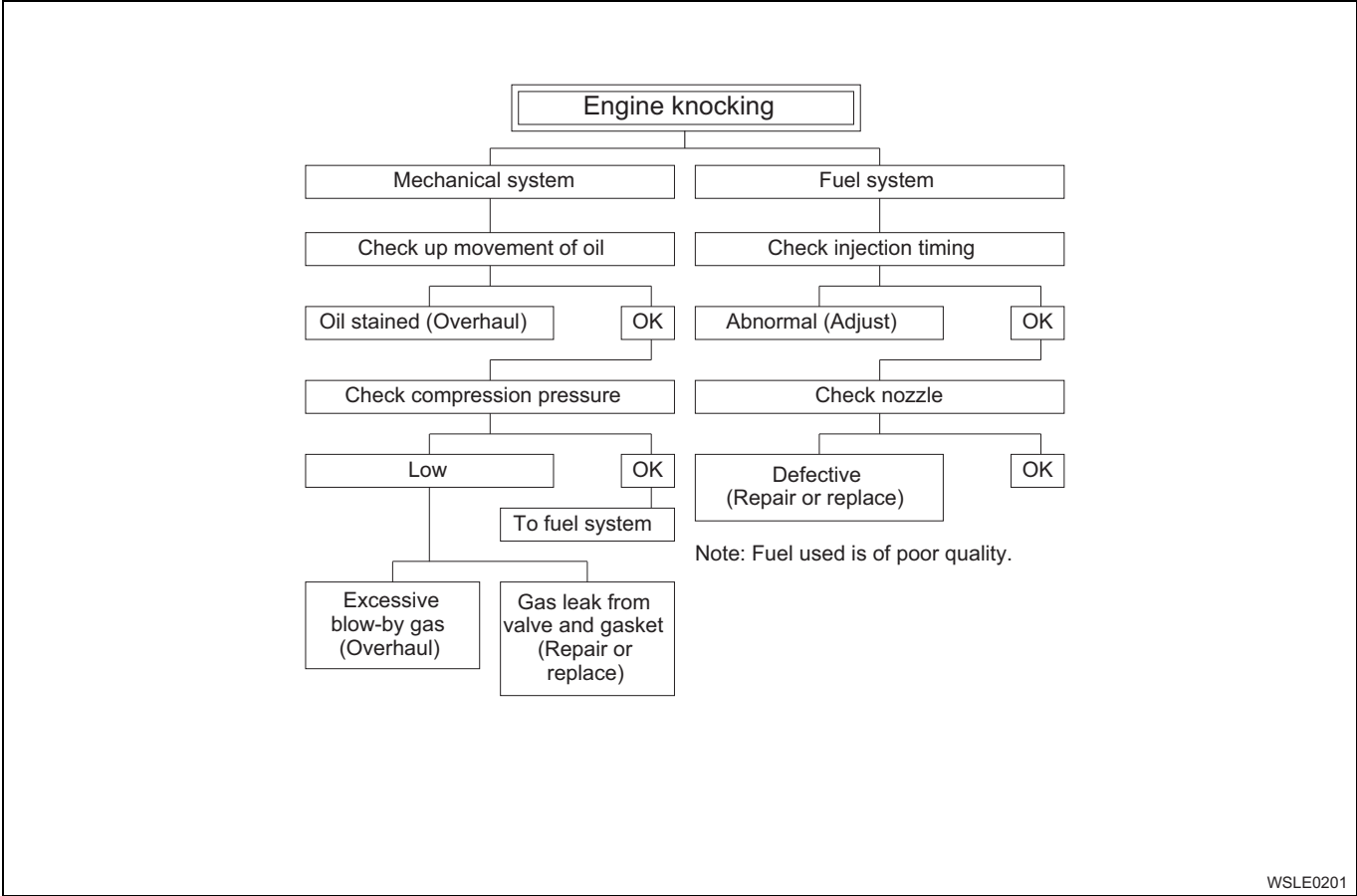

0A-24 General Information

Repair Standard

1. This table specifies the repair standard for **4LE2X model** "ISUZU diesel engine".
2. This repair standard consists of items to be checked, nominal dimension, assembly specifications, service limit, and repairing procedure.
 - "Nominal dimension" is the standard value at the time of manufacture.
 - "Assembly specification" is the target value after repairing (at assembling). It may differ in some degree from "assembly dimension" of the new engine.
 - "Service limit" is the limit value of wear, etc. which must not be exceeded. When it is reached, the part should be repaired or replaced.
 - "Repairing procedure" indicates general methods to repair.
 - The unit for the numbers in the table are all "**millimeter {inch}**" if not otherwise specified.
3. If the whole engine is requested for repair, "check the locations which need to be repaired" first by "the bench test" or something. Then perform the minimum overhaul. If a part of engine is requested for repair, perform repairing based on this "repair standard".
4. This repair standard may be changed in the value, specification, and others without notice due to "design change" of the engine.

Time to overhaul the engine

Item to be checked	Standard value	Service limit	Repairing procedure	Remarks
Compression pressure of the cylinder (MPa {psi})	3.04 {441}	2.5 {363}	Overhaul the engine.	Coolant temperature: 70 — 85°C {158 — 185°F} Engine speed: approx. 250 rpm Vary depending on altitude.
Fuel consumption rate (L/h)	100 %	140 %		
Lubricant consumption rate (L/h)	100 %	200 %		

Cylinder block

Item to be checked	Standard value	Service limit	Repairing procedure	Remarks
Wear of the cylinder bore Measurement position: 13 {0.512} lower from the top surface of the cylinder block	φ85 {3.3465}	φ85.2 {3.354}	Perform boring along the oversize piston, then perform honing.	
Distortion of upper surface of the cylinder block	0.075 {0.00295} or less	0.15 {0.006}	Repair with a surface grinder.	Maximum amount of repaired value; 0.3 {0.012} The total amount of repaired values of the cylinder head and of the cylinder block.
Water pressure test (three minutes) (kPa {psi})	490 {71}		Repair or replace the one with water leakage.	

Cylinder head

Item to be checked		Standard value	Service limit	Repairing procedure	Remarks
Valve seat depression	IN	0.7 {0.028}	1.2 {0.047}	Replace the valve and insert.	Valve seat angle is 45°
	EX	0.9 {0.035}	1.5 {0.059}		
Contact width of the valve seat		2.0 {0.079}	2.5 {0.098}	Repair with the valve seat cutter.	Wrap the contact surface sufficiently after repair.
Distortion (flatness) of the under surface (installation surface) of the cylinder head		0.075 {0.00295} or less	0.15 {0.006}	Repair with a surface grinder.	Maximum amount of repaired value; 0.3 {0.012} The total amount of repaired values of the cylinder block and of the cylinder head.
Distortion of exhaust manifold installation surface		0.05 {0.002} or less	0.2 {0.008}	Repair.	
Water pressure test (three minutes) (kPa {psi})		490 {71}		Repair or replace the one with water leakage.	
Tightening torque of the cylinder head bolt: (N·m {kgf·m/lb·ft}) (Angle method)	M12 × 1.5	83.4 — 93.2 {8.5 — 9.5/61.5 — 68.7} ↓ 60° — 90°		- Clean the seating surface and thread of the bolt. - Apply engine oil to the seating surface and thread of the bolt. - Never retighten after angle method tightening.	
	M8 × 1.25	24.5 — 34.3 {2.5 — 3.5/18.1 — 25.3}			

Piston

Item to be checked		Standard value	Service limit	Repairing procedure	Remarks
Clearance with the cylinder Grade position from the top surface: 54.85 {2.159}		0.040 — 0.085 {0.0016 — 0.0033}			
Clearance between piston pins and piston pin holes		0.004 — 0.017 {0.00016 — 0.0007}		If significant knocking sound occurs, replace the piston pin or the piston.	
Wear of the pin		φ27 {1.063}	φ26.970 {1.0618}		
Piston ring end gap	Top ring	0.20 — 0.35 {0.008 — 0.014}	1.5 {0.059}	Replace piston ring. When overhauling the engine, replace the piston ring.	
	Second ring	0.35 — 0.50 {0.014 — 0.020}			
	Oil ring	0.20 — 0.40 {0.008 — 0.016}	1.0 {0.039}		



Suggest:

For more complete manuals. Please go to the home page.

<https://www.ebooklibonline.com>

If the above button click is invalid. Please download this document first, and then click the above link to download the complete manual.

Thank you so much for reading

0A-26 General Information

Piston ring

Item to be checked		Standard value	Service limit	Repairing procedure	Remarks
Clearance between the piston ring groove and the ring	Top ring	0.085 — 0.105 {0.0033 — 0.0041}	0.2 {0.008}	Replace the ring or the piston.	When assembling the ring to the piston, be sure to assemble with the mark of the ring facing upward. Inverse assembly makes oil consumption deteriorate. The oil ring is independent of top or bottom.
	Second ring	0.050 — 0.085 {0.0020 — 0.0033}	0.15 {0.006}		
	Oil ring	0.030 — 0.070 {0.00120 — 0.00276}	0.15 {0.006}		
The ring end direction				180° alternate	

Connecting rod

Item to be checked	Standard value	Service limit	Repairing procedure	Remarks
Play of the small end and the piston boss between front and back direction (one side)	1.0 {0.039}			Reference value
Tension of the connecting rod bearing	Extrusion 0.055 — 0.085 {0.00217 — 0.00330}		Use the one with extrusion and tension, and be careful about sticking of rear side.	
Clearance between the connecting rod bearing and crank pin	0.026 — 0.067 {0.0010 — 0.0026}	0.1 {0.0039}	Replace the bearing.	Be careful with the precision of the crank pin.
Contact surface of the connecting rod bearing and crank pin			Replace the one with defective contact or abrasion.	
Clearance between the small end bushing and the piston pin	0.008 — 0.020 {0.00031 — 0.00080}	0.05 {0.002}	Replace the bushing or the pin.	Clearance should be wide enough to turn smoothly with its big end held.
Axial play of the connecting rod and the crank pin	0.20 — 0.33 {0.008 — 0.013}	0.35 {0.014}		
Center distance between the big end and small end	133.5 {5.256}			Reference value
Torsion of holes on the big end and small end (L = per 100 mm {3.937 in})	0.05 {0.002} or less	0.2 {0.008}	Repair or replace.	
Parallelism of holes on the big end and small end (L = per 100 mm {3.937 in})	0.05 {0.002} or less	0.15 {0.006}	Repair or replace.	
Tightening torque of the bearing cap bolt (N·m {kgf·m/lb·ft})	23 — 26 {2.3 — 2.7/17.0 — 19.2} → 100° — 115°		Apply engine oil to the thread of the bolt and the seating surface of the nut, and tighten.	

Crankshaft

Item to be checked	Standard value	Service limit	Repairing procedure	Remarks
Uneven wear of the journal and the pin		0.05 {0.002}	Replace the crankshaft.	
Wear of the journal	$\phi 60$ {2.362}	0.14 {0.0055}	Replace the crankshaft.	
Wear of the pin	$\phi 46$ {1.811}	0.13 {0.005}	Replace the crankshaft.	
Finishing precision of the journal and the pin (taper and ellipse)	0.007 {0.00028} for both ellipse and taper			
Tension of the journal bearing	Extrusion 0.02 — 0.06 {0.0008 — 0.00236}		Use the one with extrusion and tension, and be careful about sticking of rear side.	
Clearance between the journal and the bearing	0.029 — 0.072 {0.0011 — 0.0028}	0.11 {0.0043}	Replace the bearing.	
Axial play of the crankshaft	0.058 — 0.208 {0.0023 — 0.0082}	0.3 {0.012}	Replace the thrust bearing.	Measure at the front of the thrust in No.2 journal portion of the crankshaft.
Crankshaft runout	0.025 {0.00098} or less	0.05 {0.002}	Replace.	
Ring gear			Chamfer the warped ones and replace the remarkably damaged ones.	
Balance of the crankshaft (N·cm {gf·cm/on-in})	0.20 {20/ 0.2778} or less		Check the dynamic balance.	(Reference value) At both ends of the journal
Tightening torque of the crank bearing cap bolt (N·m {kgf·m/lb·ft})	83.4 — 93.2 {8.5 — 9.5/ 61.5 — 68.7}		Apply engine oil to the thread and the seating surface of the bolt, and tighten.	Be sure that there is no scratch or foreign object pinched on the bearing cap match surface.
Wear of the oil seal in the crankshaft rear part			Replace the oil seal when there is oil leakage.	Be careful with the oil seal collapsed. (Apply oil sufficiently before assembly.)

Camshaft

Item to be checked	Standard value	Service limit	Repairing procedure	Remarks
Uneven wear of the center journal		0.05 {0.002}	Repair or replace the camshaft.	
Wear of the center journal	$\phi 52$ {2.047}	$\phi 51.92$ {2.044}	Replace the camshaft.	
Camshaft runout	0.02 {0.0008} or less	0.1 {0.0039}	Replace the camshaft.	
Height of the cam	Inlet	6.13 {0.241}	Replace the camshaft.	Repair light stepped wear of the cam.
	Exhaust	6.43 {0.253}		

<https://www.ebooklibonline.com>

Hello dear friend!

Thank you very much for reading.

Enter the link into your browser.

The full manual is available for immediate download.

<https://www.ebooklibonline.com>