

ISUZU

WORKSHOP MANUAL

INDUSTRIAL

DIESEL ENGINE

A-4BG1, A-6BG1

MODELS

FOREWORD

This Workshop Manual is designed to help you perform necessary maintenance, service, and repair procedures on applicable Isuzu industrial engines.

Information contained in this Workshop Manual is the latest available at the time of publication.

Isuzu reserves the right to make changes at any time without prior notice.

The Table of Contents at the right hand side of this page shows you the general arrangement of the material in this Workshop Manual. A more detailed Table of Contents precedes each individual section.

The black spot at the right hand side of some pages indicates the first page of a given section.

This Workshop Manual is applicable to 1995 and later models.

TABLE OF CONTENTS

SECTION	NAME
1	GENERAL INFORMATION
2	MAINTENANCE
3	ENGINE ASSEMBLY I (DISASSEMBLY)
4	ENGINE ASSEMBLY II (INSPECTION & REPAIR)
5	ENGINE ASSEMBLY III (REASSEMBLY)
6	LUBRICATING SYSTEM
7	COOLING SYSTEM
8	FUEL SYSTEM
9	TURBOCHARGER
10	AIR COMPRESSOR
11	ENGINE ELECTRICALS
12	TROUBLESHOOTING
13	SPECIAL TOOL LIST
14	CONVERSION TABLE

SECTION 1

GENERAL INFORMATION

TABLE OF CONTENTS

ITEM	PAGE
General repair instructions	1- 2
Notes on the format of this manual.....	1- 2
Main data and specifications	1- 6
Tightening torque specifications	1- 8
Angular nut and bolt tightening method.....	1-10
Major parts fixing nuts and bolts.....	1-12
Identifications	1-23

GENERAL REPAIR INSTRUCTIONS

1. Before performing any service operation with the engine mounted, disconnect the grounding cable from the battery.
This will reduce the chance of cable damage and burning due to short circuiting.
2. Always use the proper tool or tools for the job at hand.
Where specified, use the specially designed tool or tools.
3. Use genuine ISUZU parts referring ISUZU PARTS CATALOG for the engines surely.
4. Never reuse cotter pins, gaskets, O-rings, lock washers, and self locking nuts. Discard them as you remove them. Replace them with new ones.
5. Always keep disassembled parts neatly in groups. This will ensure a smooth reassembly operation.
It is especially important to keep fastening parts separate. These parts vary in hardness and design, depending on their installation position.
6. All parts should be carefully cleaned before inspection or reassembly.
Oil ports and other openings should be cleaned with compressed air to make sure that they are completely free of obstructions.
7. Rotating and sliding part surfaces should be lubricated with oil or grease before reassembly.
8. If necessary, use a sealer on gaskets to prevent leakage.
9. Nut and bolt torque specifications should be carefully followed.
10. Always release the air pressure from any machine-mounted air tank(s) before dismantling the engine or disconnecting pipes and hoses. To not do so is extremely dangerous.
11. Always check and recheck you work. No service operation is complete until you have done this.
12. Information contained in the "Main Data and Specifications" of the Workshop Manual and the Instruction Book may differ. In this case, the information contained in the Instruction Book should be considered applicable.

NOTES ON THE FORMAT OF THIS MANUAL

This Workshop Manual is applicable to the 4BG1, 4BG1T, 6BG1, and 6BG1T family of industrial diesel engines. Unless otherwise specified, these engines have common parts and components as well as data and specifications.

Illustrations used in this Workshop Manual are based on the 6BG1 and 6BG1T engines.

The 4BG1T engine and the 6BG1T engine are turbocharged.

1. Find the applicable section by referring to the Table of Contents at the beginning of the Manual.
2. Common technical data such as general maintenance items, service specifications, and tightening torques are included in the "General Information" section.
3. Each section is divided into sub-sections dealing with disassembly, inspection and repair, and reassembly.
The section ENGINE ASSEMBLY is an exception. This part is divided into three sections to facilitates quick indexing.
4. When the same servicing operation is applicable to several different units, the manual will direct you to the appropriate page.
5. For the sake of brevity, self-explanatory removal and installation procedures are omitted.
More complex procedures are covered in detail.

<https://www.ebooklibonline.com>

Hello dear friend!

Thank you very much for reading.

Enter the link into your browser.

The full manual is available for immediate download.

<https://www.ebooklibonline.com>

6. Each service operation section in this Workshop Manual begins with an exploded view of the applicable area. A brief explanation of the notation used follows.

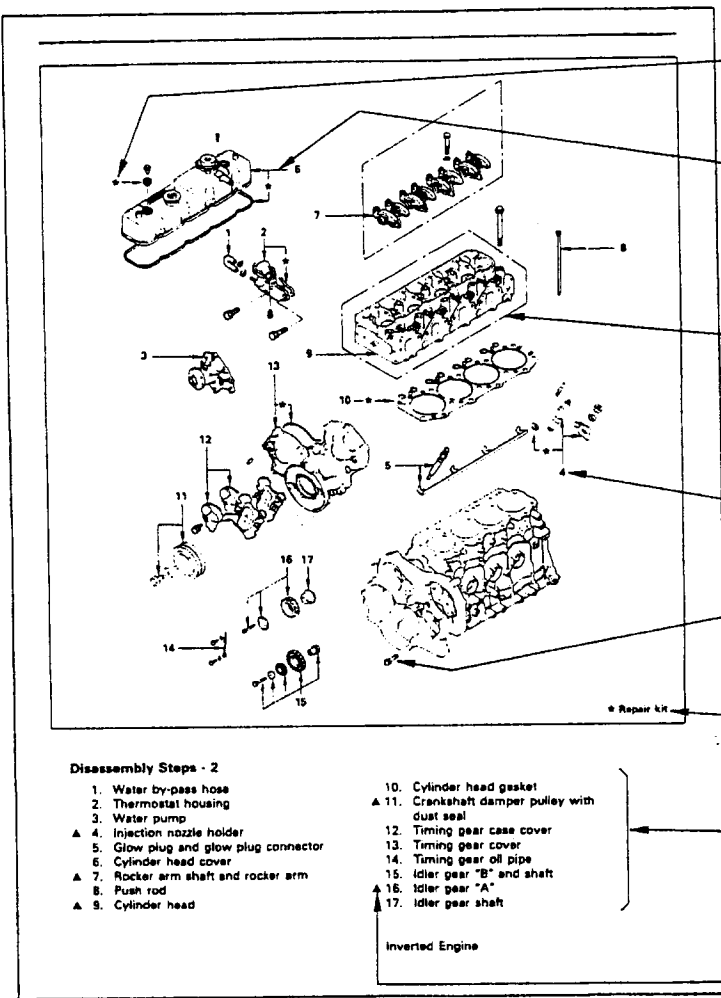

- Parts marked with an asterisk (*) are included in the repair kit.
- Parts within a square frame are to be removed and installed as a single unit.
- All parts within an irregularly shaped frame form a single assembly. They are considered a "major component". Individual parts within the irregularly shaped frame are considered "minor components".
- The number tells you the service operation sequence.
- Removal of unnumbered parts is unnecessary unless replacement is required.
- The "*" Repair Kit" indicates that a repair kit is available.
- The parts listed under "Reassembly Steps" or "Installation Steps" are in the service operation sequence.
- The removal or installation of parts marked with a triangle (▲) is an important operation. Detailed information is given in the text.

1-4 GENERAL INFORMATION

7. Below is a sample of the text of the Workshop Manual.

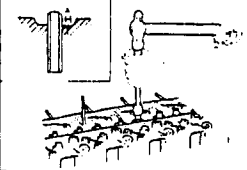

Valve Guide Installation

1. Lubricate the valve guide outer face with engine oil.
2. Attach the installer to the valve guide.
3. Use a hammer to drive the valve guide into position from the cylinder head upper face.
Valve Guide Installer: 1-85220-001-0
4. Measure the height of the valve guide upper end from the upper face of the cylinder head.

Valve Guide Upper End Height (H)	mm(in)
14.1	(0.56)

Note:
If the valve guide has been removed, both the valve and the valve guide must be replaced with new ones as a set.
Be absolutely sure to discard the used valves and valve guides.

This is the item shown in the illustration. It is marked with a triangle (▲) on the Major Components page.

Special tools are identified by the tool name and/or number.

















The illustration shows how the special tool is to be used.

Letters and numbers contained in a circle refer to the illustration.

Symbols indicate the type of service operation or step to be performed. A detailed explanation of these symbols follows.

Service data and specifications are given in this table.

8. The following symbols appear throughout this Workshop Manual. They tell you the type of service operation or step to perform.

- | | |
|---|---|
| <p> ... Removal</p> | <p> ... Adjustment</p> |
| <p> ... Installation</p> | <p> ... Cleaning</p> |
| <p> ... Disassembly</p> | <p> ... Important Operation Requiring Extra Care</p> |
| <p> ... Reassembly</p> | <p> ... Specified Torque (Tighten)</p> |
| <p> ... Alignment (Marks)</p> | <p> ... Special Tool Use Required or Recommended (Isuzu Tool or Tools)</p> |
| <p> ... Directional Indication</p> | <p> ... Commercially Available Tool Use Required or Recommended</p> |
| <p> ... Inspection</p> | <p> ... Lubrication (Oil)</p> |
| <p> ... Measurement</p> | <p> ... Lubrication (Grease)</p> |
| <p> ... Sealant Application</p> | |

9. Measurement criteria are defined by the terms "standard" and "limit".

A measurement falling within the "standard" range indicates that the applicable part or parts are serviceable.

"Limit" should be thought of as an absolute value.

A measurement which is outside the "limit" indicates that the applicable part or parts must be either repaired or replaced.

10. Components and parts are listed in the singular form throughout the Manual.

11. Directions used in this Manual are as follows:

Front

The cooling fan side of the engine viewed from the flywheel.

Right

The injection pump side of the engine.

Left

The exhaust manifold side of the engine.

Rear

The flywheel side of the engine.

Cylinder numbers are counted from the front of the engine.

The front most cylinder is No. 1 and rear most cylinder is No. 4 or No. 6.

The engine's direction of rotation is counterclockwise viewed from the flywheel.

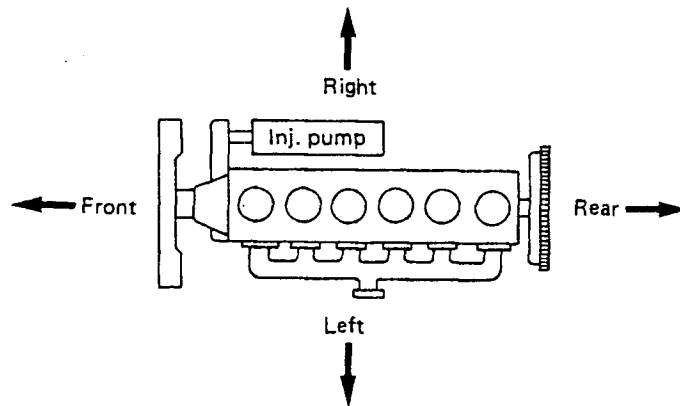

MAIN DATA AND SPECIFICATIONS

Engine Model		A-4BG1	A-4BG1T
Item			
Engine type		Water cooled, four cycle, vertical in-line overhead valve	
Combustion chamber type		Direct injection	
Cylinder liner type		Dry	
No. of cylinders – bore x stroke	mm (in)	4 – 105 x 125 (4.13 x 4.92)	
Total piston displacement	L (cid)	4.329 (464)	
Compression ratio		17.0 to 1	
* Engine dimensions	mm (in)	842 x 645 x 775 (33.1 x 25.4 x 30.5)	878 x 702 x 883 (34.6 x 27.6 x 34.8)
Length x width x height			
* Engine weight (Dry)	kg (lb)	325 (716)	361 (796)
Fuel injection order		1-3-4-2	
Specified fuel		Diesel fuel (ASTM D975 No. 2D)	
Injection pump		In-line plunger, Bosch A type	
Governor		Mechanical, RSV type	
Injection nozzle		Multi hole	
Injection starting pressure	MPa (kg/cm ² /psi)	14.7 (150/2,130)	18.1 (185/2,630)
Fuel filter type		Center bolt or cartridge (spin-on)	
Water sedimentor	(If so equipped)	Sediment/water level indicating type	
Compression pressure	MPa (kg/cm ² /psi) (At warm)	3.04 (31/441) at 200 rpm at sea level	
Valve clearances (At cold)	Intake mm (in)	0.40 (0.016)	
	Exhaust mm (in)	0.40 (0.016)	
Lubrication method		Pressurized circulation	
Oil pump		Gear type	
Main oil filter type		Full flow, cartridge (spin-on)	
* Lubricating oil volume	L (US gal)	13.2 (3.5)	
Oil cooler		Water cooled integral type	
Cooling method		Pressurized forced circulation	
Coolant volume (engine only)	L (US gal)	8.5 (2.25)	
Water pump		Belt driven impeller type	
Thermostat type		Wax pellet type	
* Generator	V-A	24-40	
* Starter	V-KW	24-4.5	
* Turbocharger manufacturer		-	MITSUBISHI
* Turbocharger model		-	TD04H

- Note:** 1. These specifications are based on the standard engine.
2. Specifications for items marked with an asterisk (*) will vary according to the type of equipment on which the engine is installed.
If you are unable to locate the data applicable to these specifications, please contact Isuzu Motors LTD through your machine supplier.

MAIN DATA AND SPECIFICATIONS

Engine Model		A-6BG1	A-6BG1T
Item			
Engine type		Water cooled, four cycle, vertical in-line overhead valve	
Combustion chamber type		Direct injection	
Cylinder liner type		Dry	
No. of cylinders - bore × stroke	mm (in)	6 - 105.0 × 125.0 (4.13 × 4.92)	
Total piston displacement	L (cid)	6.494 (396)	
Compression ratio		17.5 to 1	
* Engine dimensions	mm (in)	1122 × 648 × 775	1193 × 739 × 949
Length × width × height		(44.2 × 25.5 × 30.5)	(47.0 × 29.1 × 37.4)
* Engine weight (Dry)	kg (lb)	458 (1009)	489 (1078)
Fuel injection order		1-5-3-6-2-4	
Specified fuel		Diesel fuel (ASTM D975 No. 2D)	
Injection pump		In-line plunger, Bosch AD type	
Governor		Mechanical, RSV type	
Injection nozzle		Multi hole	
Injection starting pressure MPa (kg/cm ² /psi)		18.1 (185/2,630)	
Fuel filter type		Cartridge (spin-on)	
Water sedimentor	(If so equipped)	Sedimenter/water level indicating type	
Compression pressure	MPa (kg/cm ² /psi)	3.04 (31/441) at 200 rpm, at sea level	
	(At warm)		
Valve clearances (At cold)	Intake mm (in)	0.40 (0.016)	
	Exhaust mm (in)	0.40 (0.016)	
Lubrication method		Pressurized circulation	
Oil pump		Gear type	
Main oil filter type		Centerbolt, fullflow or cartridge (spin-on)	
Partial oil filter		Equipped by OEM	
* Lubricating oil volume	L (US gal)	21.5 (5.68)	
Oil cooler		Water cooled integral type	
Cooling method		Pressurized forced circulation	
Coolant volume (engine only)	L (US gal)	12 (3.2)	
Water pump		Belt driven impeller type	
Thermostat type		Wax pellet type	
* Generator	V-A	24-40	
* Starter	V-KW	24-4.5	
* Turbocharger manufacturer		-	IHI
* Turbocharger model		-	RHE6









- Note:**
- These specifications are based on the standard engine.
 - Specifications for items marked with an asterisk (*) will vary according to the type of equipment on which the engine is installed.
- If you are unable to locate the data applicable to these specifications, please contact Isuzu Motors LTD through your machine supplier.

TIGHTENING TORQUE SPECIFICATIONS

The tightening torque values given in the table below are applicable to the bolts unless otherwise specified.

STANDARD BOLT

N·m (kgf·m)

Bolt Identification Bolt Diameter × pitch (mm)				
				
M 6 × 1.0	3.9~ 7.8 { 0.4~ 0.8}	4.9~ 9.8 { 0.5~ 1.0}		
M 8 × 1.25	7.8~ 17.7 { 0.8~ 1.8}	11.8~ 22.6 { 1.2~ 2.3}		16.7~ 30.4 { 1.7~ 3.1}
M10 × 1.25	20.6~ 34.3 { 2.1~ 3.5}	27.5~ 46.1 { 2.8~ 4.7}		37.3~ 62.8 { 3.8~ 6.4}
* M10 × 1.5	19.6~ 33.4 { 2.0~ 3.4}	27.5~ 45.1 { 2.8~ 4.6}		36.3~ 59.8 { 3.7~ 6.1}
M12 × 1.25	49.1~ 73.6 { 5.0~ 7.5}	60.8~ 91.2 { 6.2~ 9.3}		75.5~114.0 { 7.7~11.6}
* M12 × 1.75	45.1~ 68.7 { 4.6~ 7.0}	56.9~ 84.4 { 5.8~ 8.6}		71.6~107.0 { 7.3~10.9}
M14 × 1.5	76.5~115.0 { 7.8~11.7}	93.2~139.0 { 9.5~14.2}		114.0~171.0 {11.6~17.4}
* M14 × 2.0	71.6~107.0 { 7.3~10.9}	88.3~131.0 { 9.0~13.4}		107.0~160.0 {10.9~16.3}
M16 × 1.5	104.0~157.0 {10.6~16.0}	135.0~204.0 {13.8~20.8}		160.0~240.0 {16.3~24.5}
* M16 × 2.0	100.0~149.0 {10.2~15.2}	129.0~194.0 {13.2~19.8}		153.0~230.0 {15.6~23.4}
M18 × 1.5	151.0~226.0 {15.4~23.0}	195.0~293.0 {19.9~29.9}		230.0~345.0 {23.4~35.2}
* M18 × 2.5	151.0~226.0 {15.4~23.0}	196.0~294.0 {20.0~30.0}		231.0~346.0 {23.6~35.3}
M20 × 1.5	206.0~310.0 {21.0~31.6}	270.0~405.0 {27.5~41.3}		317.0~476.0 {32.3~48.5}
* M20 × 2.5	190.0~286.0 {19.4~29.2}	249.0~375.0 {25.4~38.2}		293.0~440.0 {29.9~44.9}
M22 × 1.5	251.0~414.0 {25.6~42.2}	363.0~544.0 {37.0~55.5}		425.0~637.0 {43.3~64.9}
* M22 × 2.5	218.0~328.0 {22.2~33.4}	338.0~507.0 {34.5~51.7}		394.0~592.0 {40.2~60.4}
M24 × 2.0	359.0~540.0 {36.6~55.0}	431.0~711.0 {43.9~72.5}		554.0~831.0 {56.5~84.7}
* M24 × 3.0	338.0~507.0 {34.5~51.7}	406.0~608.0 {41.4~62.0}		521.0~782.0 {53.1~79.7}

An asterisk (*) indicates that the bolts are used for female threaded parts that are made of soft materials such as casting.

TIGHTENING TORQUE SPECIFICATIONS

The tightening torque values given in the table below are applicable to the bolts unless otherwise specified.

FLANGED HEAD BOLT

N·m (kgf·m)

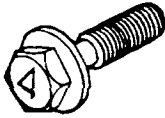
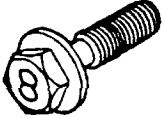
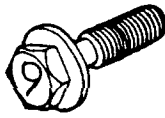
Bolt Identification Bolt Diameter × pitch (mm)			
M 6 × 1.0	4.6~ 8.5 { 0.5~ 0.9}	6.6~ 12.2 { 0.6~ 1.2}	—————
M 8 × 1.25	10.5~ 19.6 { 1.1~ 2.0}	15.3~ 28.4 { 1.6~ 2.9}	18.1~ 33.6 { 2.1~ 3.4}
M10 × 1.25	23.1~ 38.5 { 2.4~ 3.9}	35.4~ 58.9 { 3.6~ 6.1}	42.3~ 70.5 { 4.3~ 7.2}
* M10 × 1.5	22.3~ 37.2 { 2.3~ 3.8}	34.5~ 57.5 { 3.5~ 5.8}	40.1~ 66.9 { 4.1~ 6.8}
M12 × 1.25	54.9~ 82.3 { 5.6~ 8.4}	77.7~117.0 { 7.9~11.9}	85.0~128.0 { 8.7~13.0}
* M12 × 1.75	51.0~ 76.5 { 5.2~ 7.8}	71.4~107.0 { 7.3~10.9}	79.5~119.0 { 8.1~12.2}
M14 × 1.5	83.0~125.0 { 8.5~12.7}	115.0~172.0 {11.7~17.6}	123.0~185.0 {12.6~18.9}
* M14 × 2.0	77.2~116.0 { 7.9~11.8}	108.0~162.0 {11.1~16.6}	116.0~173.0 {11.8~17.7}
M16 × 1.5	116.0~173.0 {11.8~17.7}	171.0~257.0 {17.4~26.2}	177.0~265.0 {18.0~27.1}
* M16 × 2.0	109.0~164.0 {11.2~16.7}	163.0~244.0 {16.6~24.9}	169.0~253.0 {17.2~25.8}

A bolt with an asterisk (*) is used for female screws of soft material such as cast iron.



ANGULAR NUT AND BOLT TIGHTENING METHOD



1. Carefully wash the nuts and bolts to remove all oil and grease.

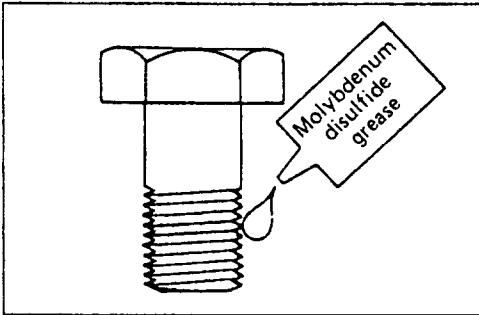

2. Apply a coat of molybdenum disulfide grease to the threads and setting faces of the nuts and bolts.

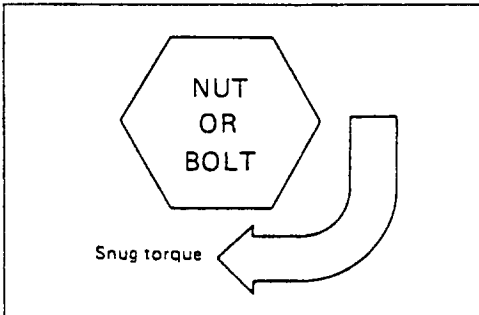

3. Tighten the nuts and bolts to the specified torque (snug torque) with a torque wrench.

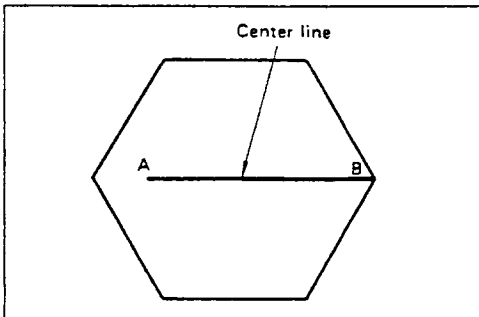

4. Draw a line [A-B] across the center of each bolt.

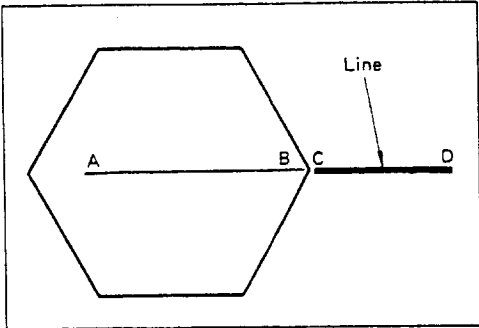

5. Draw another line (C-D) on the face of each of the parts to be clamped. This line should be an extension of the line [A-B].

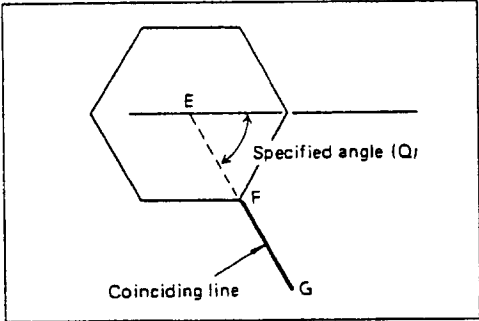

6. Draw another line [F-G] on the face of each of the parts to be clamped. This line will be in the direction of the specified angle (Q) across the center [E] of the nut or bolt.

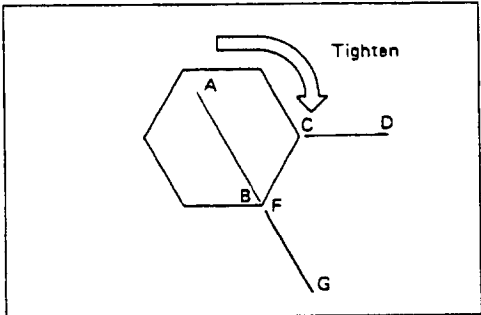

7. Use a socket wrench to tighten each nut or bolt to the point where the line [A-B] is aligned with the line [F-G].

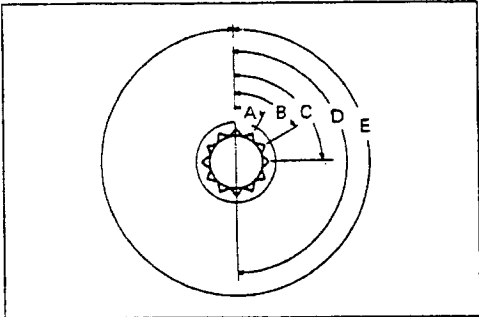

Example: Specified Angle and Tightening Rotation

A	30°	1/12 of a turn
B	60°	1/6 of a turn
C	90°	1/4 of a turn
D	180°	1/2 of a turn
E	360°	One full turn

MAJOR PART FIXING NUTS AND BOLTS

Cylinder Head and Cover

N·m (kgf·m/ft.lb)

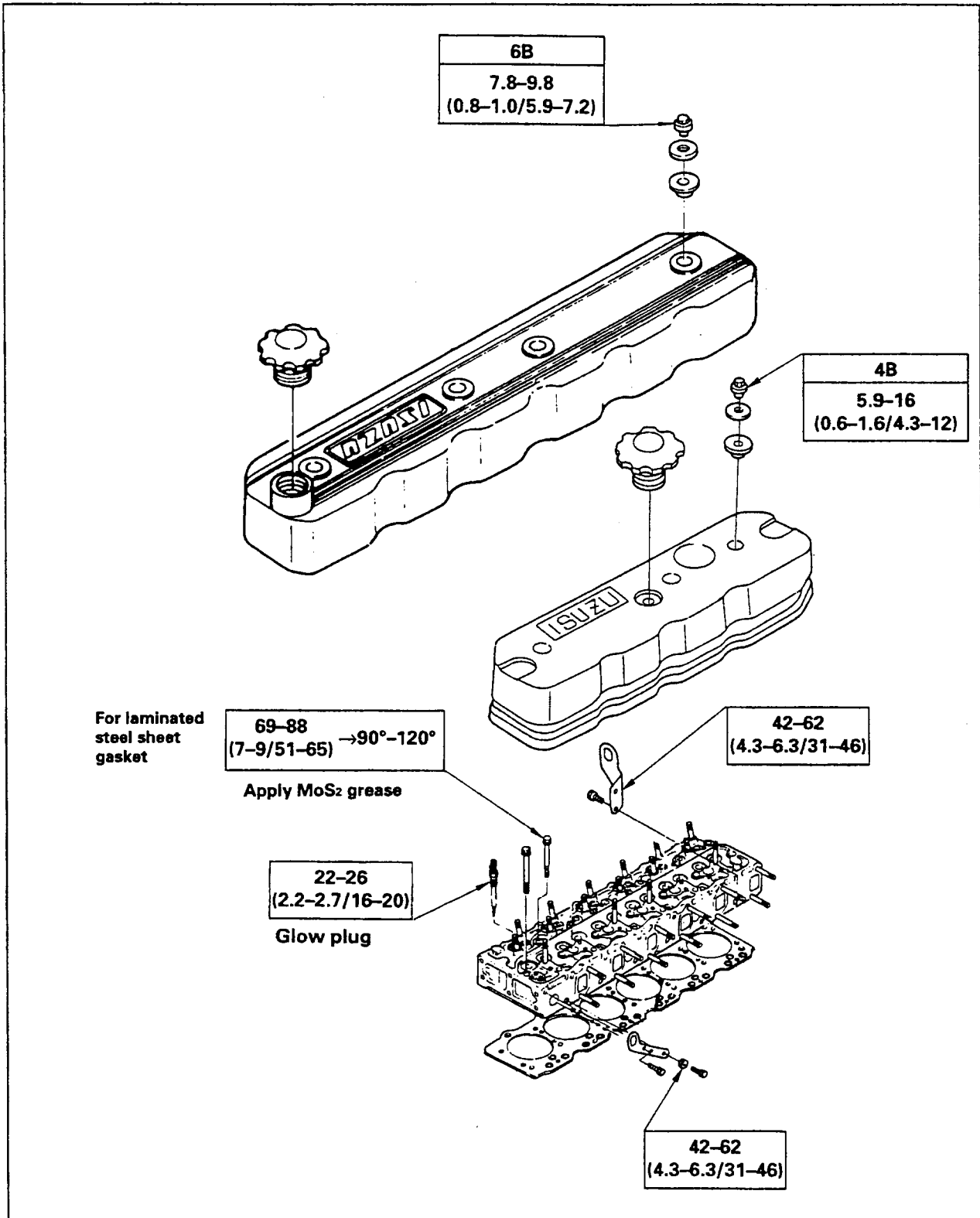

Mos₂ Molybdenum disulfide paste.

Cylinder Body

N·m (kgf·m/ft.lb)

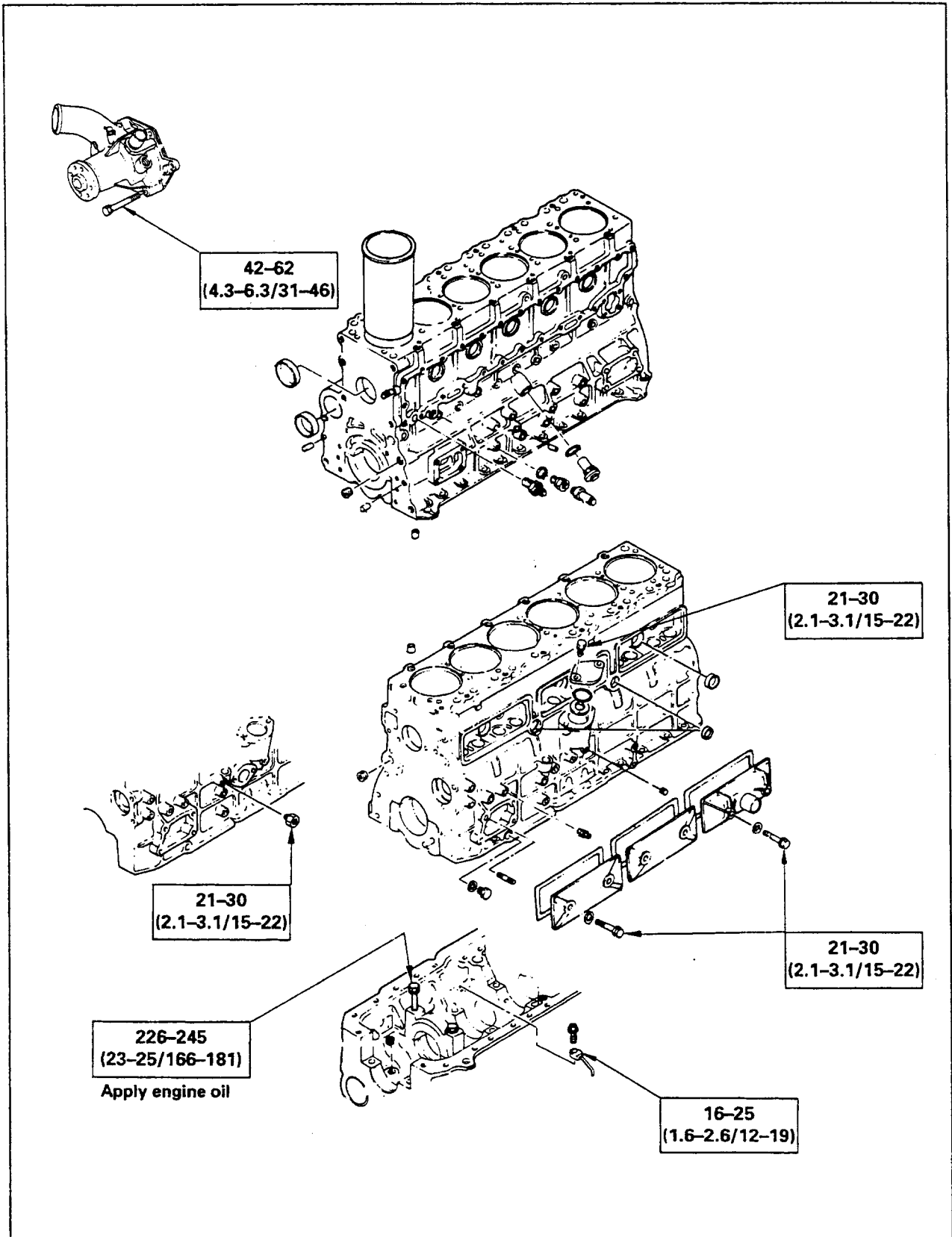

Oil Pan and Dipstick

N·m (kgf·m/ft.lb)

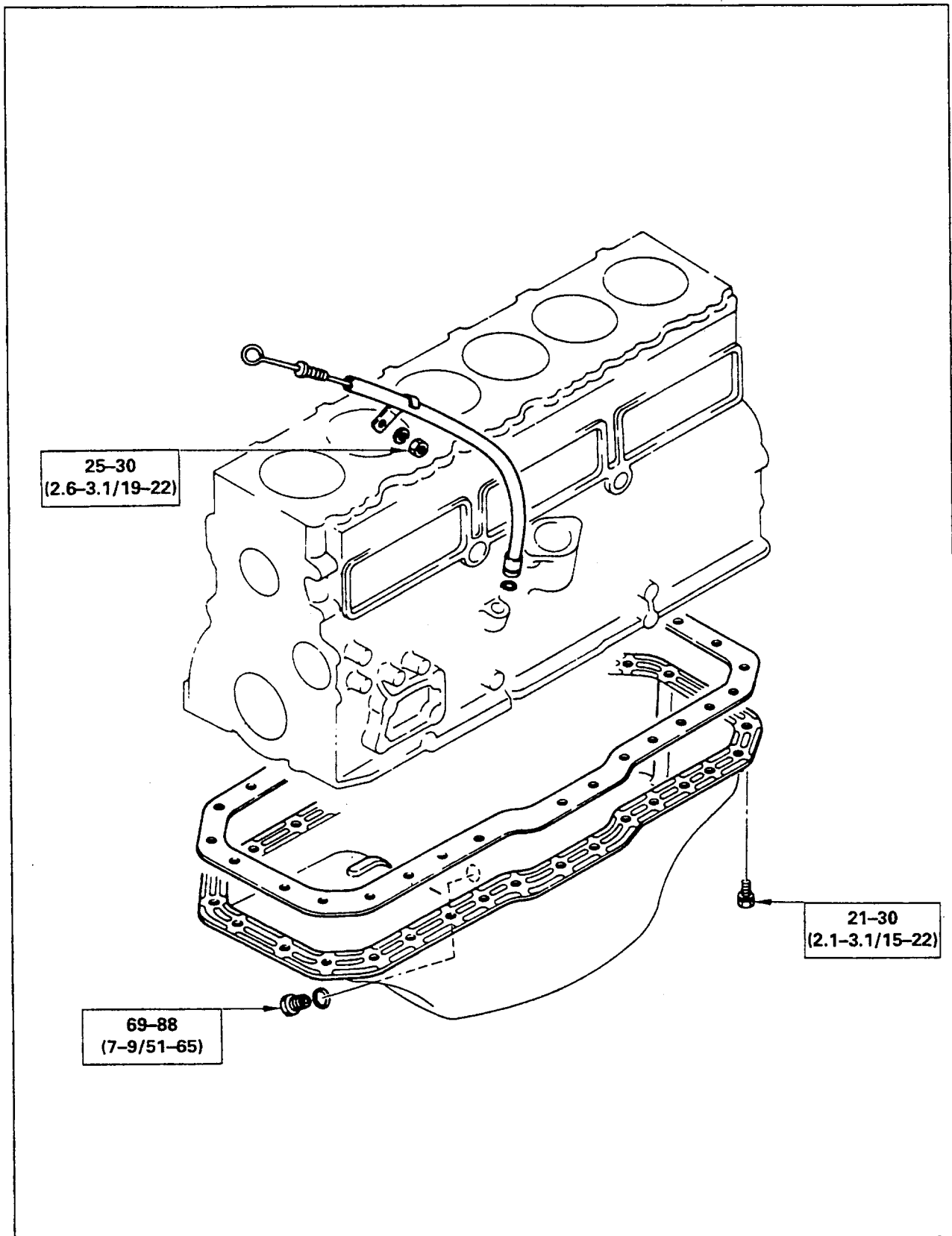

Camshaft and Rocker Arm

N·m (kgf·m/ft·lb)

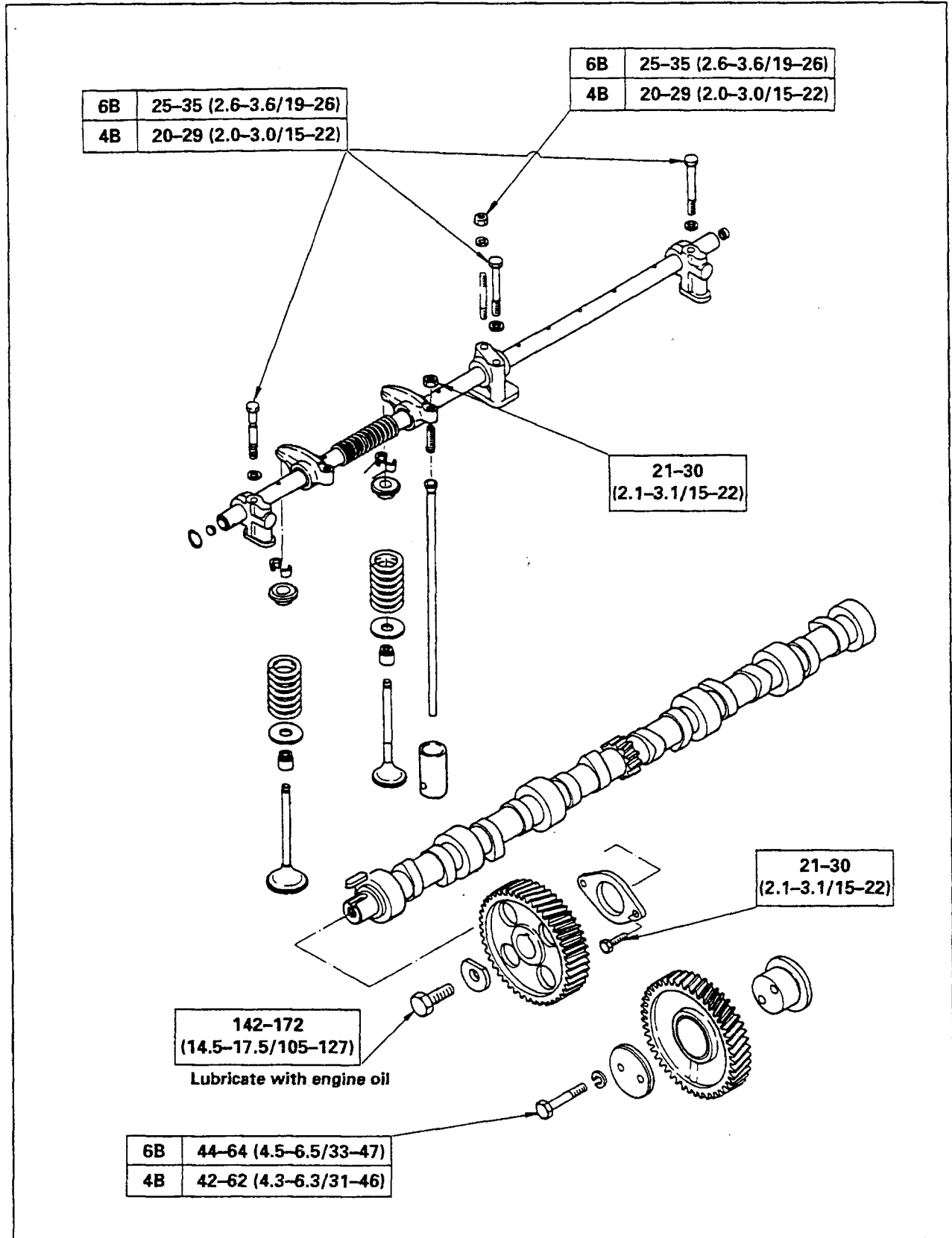

Crankshaft, Piston, and Flywheel

N·m (kgf·m/ft.lb)

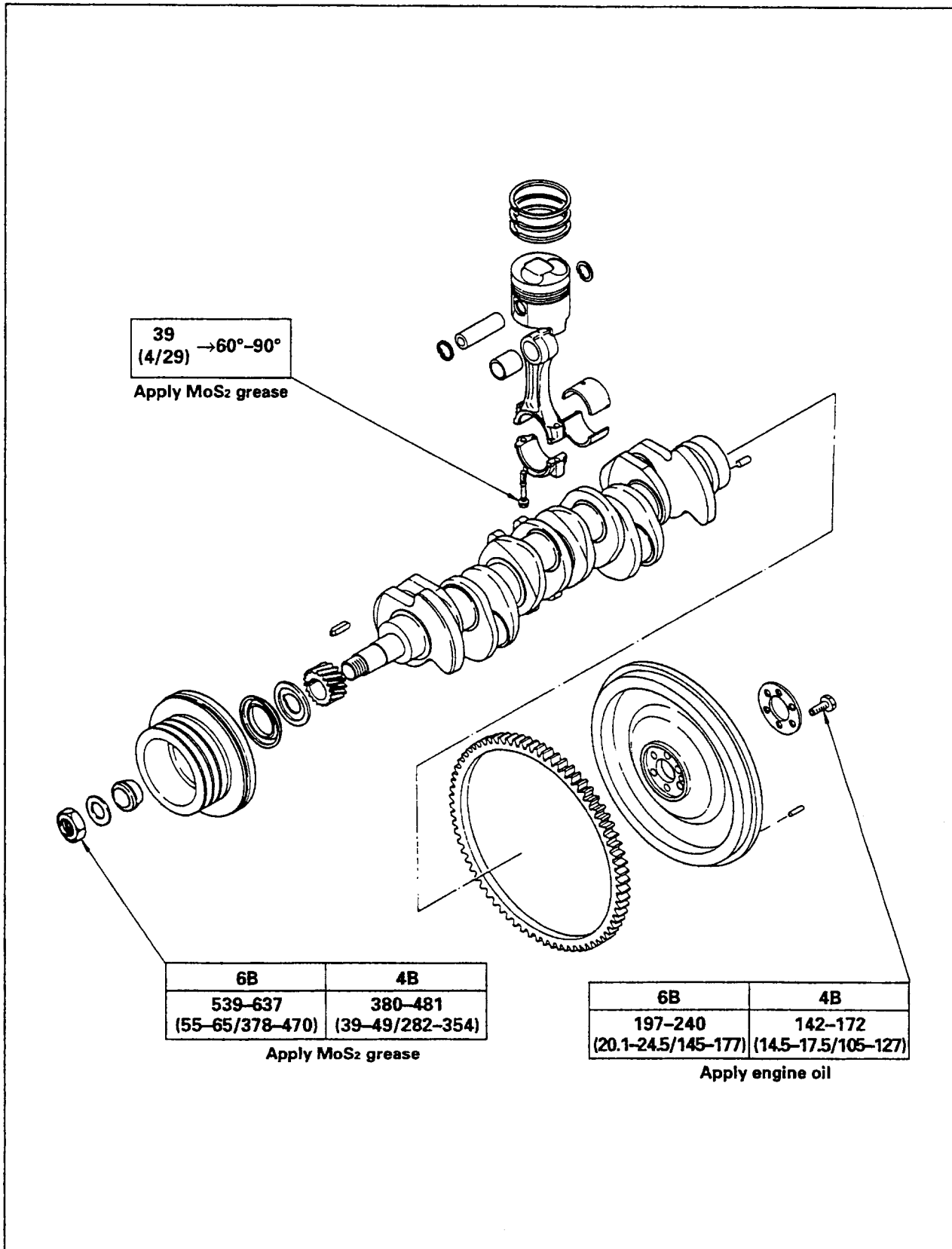



Suggest:

For more complete manuals. Please go to the home page.

<https://www.ebooklibonline.com>

If the above button click is invalid. Please download this document first, and then click the above link to download the complete manual.

Thank you so much for reading

Thermostat and Thermostat Housing

N·m (kgf·m/ft.lb)

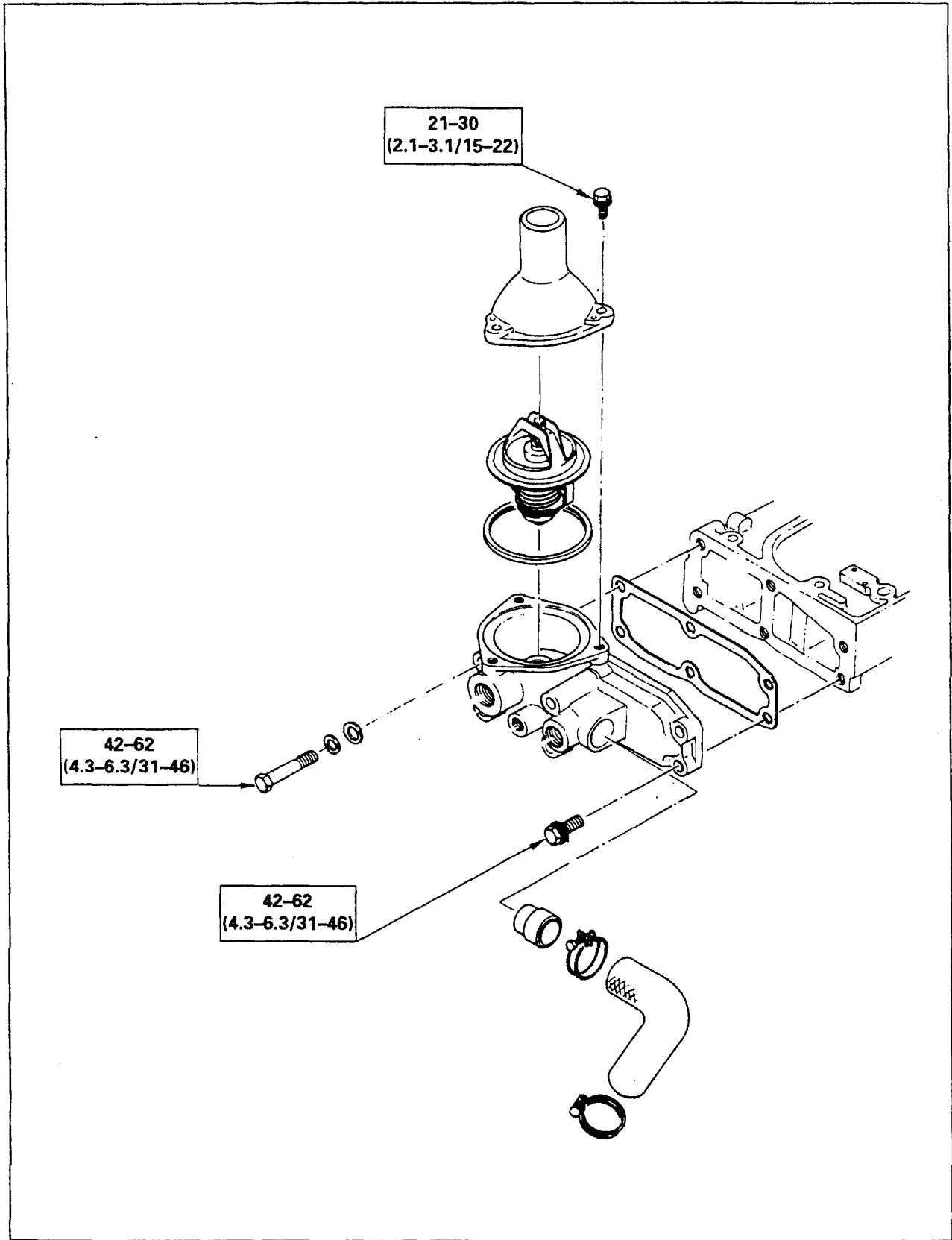

Intake and Exhaust Manifold

N·m (kgf·m/ft.lb)

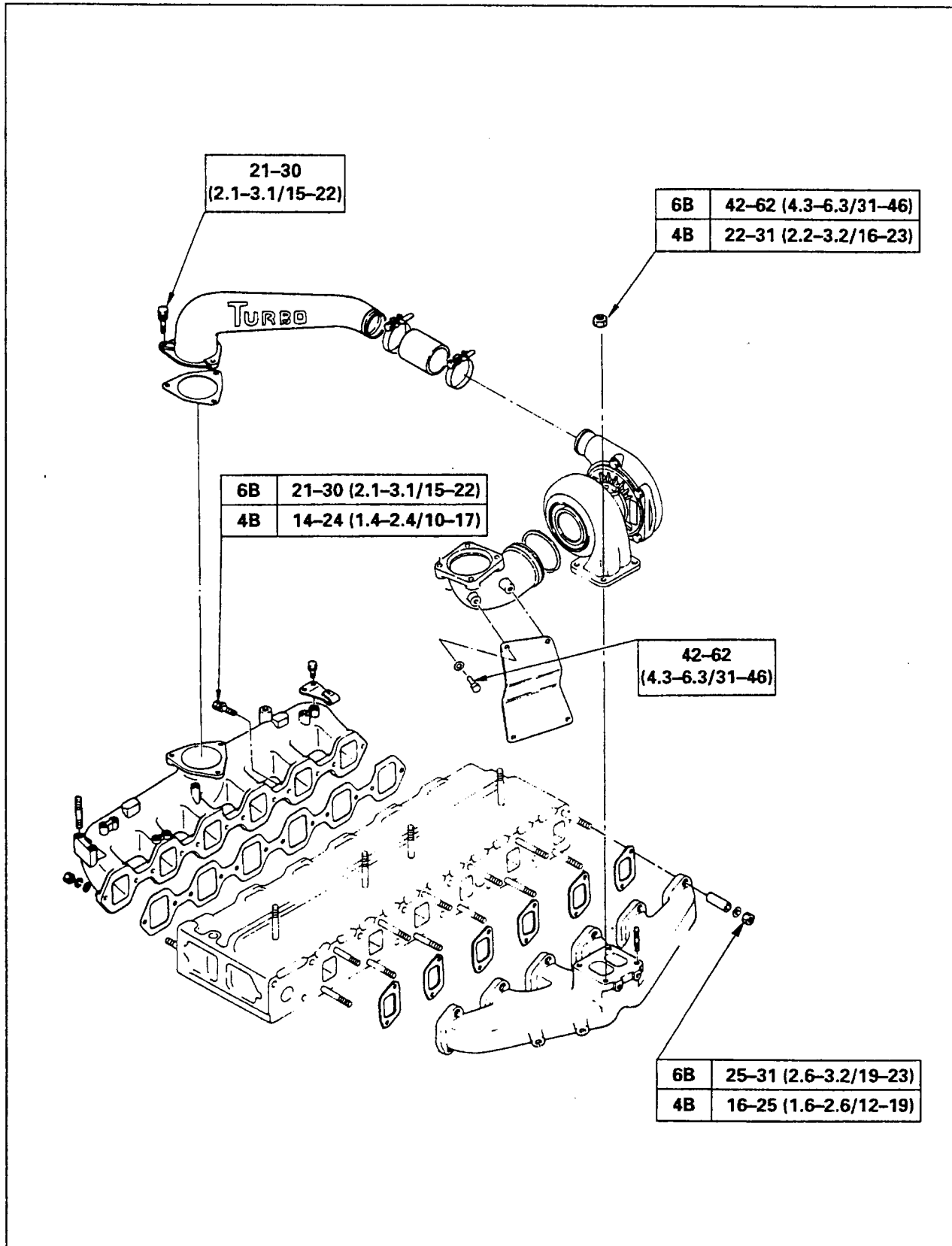

<https://www.ebooklibonline.com>

Hello dear friend!

Thank you very much for reading.

Enter the link into your browser.

The full manual is available for immediate download.

<https://www.ebooklibonline.com>