

ISUZU
WORKSHOP MANUAL
INDUSTRIAL
DIESEL ENGINE
4JA1 (4JB1) 4JC1
MODELS

FOREWORD

This Workshop Manual is designed to help you perform necessary maintenance, service, and repair procedures on applicable Isuzu industrial engines.

Information contained in this Workshop Manual is the latest available at the time of publication.

Isuzu reserves the right to make changes at any time without prior notice.

The Table of Contents at the right hand side of this page shows you the general arrangement of the material in this Workshop Manual. A more detailed Table of Contents precedes each individual section.

The black spot at the right hand side of some pages indicates the first page of a given section.

This Workshop Manual is applicable to 1986 and later models.

TABLE OF CONTENTS

SECTION	NAME
1	GENERAL INFORMATION
2	MAINTENANCE
3	ENGINE ASSEMBLY I (DISASSEMBLY)
4	ENGINE ASSEMBLY II (INSPECTION & REPAIR)
5	ENGINE ASSEMBLY III (REASSEMBLY)
6	LUBRICATING SYSTEM
7	COOLING SYSTEM
8	FUEL SYSTEM
9	ENGINE ELECTRICALS
10	TROUBLESHOOTING
11	SPECIAL TOOL LIST

STANDARD TIGHTENING TORQUE TABLE FOR FLANGED HEX HEAD BOLTS

The tightening torques in the next table apply to such areas that do not specify special tightening torques.

1. Reason for change ; It has been decided to use flanged hex head bolts in place of hex head bolts. The tightening torques for the flanged hex head bolts have been increased by about 10% as compared to conventional torques in order to get the same axial force as conventional hex head bolts, except part of special bolts (connecting rod bolts, etc.). We therefore request that this decision be made known to all personnel of your service department by referring to standard tightening torques for conventional hex head bolts and new flanged hex head bolts.

2. Time of execution ; At the latter part of August 1995.

3. Change contents ; **[Present]** **[New]**

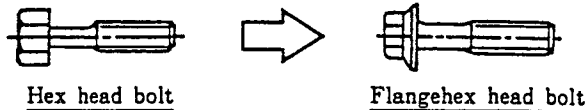

4. Interchangeability ; New \longleftrightarrow Old

5. Applicable engine model ; All engines

kg·m (lb·ft)

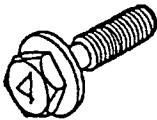
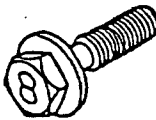
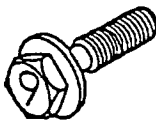
Class	4.8	8.8	9.8
Bolt identification			
Bolt diameter × pitch (mm)			
M 6 × 1.0	0.5~0.9 (3.6~6.5)	0.6~1.2 (4.6~8.7)	—————
M 8 × 1.25	1.1~2.0 (8.0~14)	1.6~2.9 (12~21)	2.1~3.4 (15~25)
M10×1.25	2.4~3.9 (17~28)	3.6~6.1 (26~44)	4.3~7.2 (31~52)
※M10×1.5	2.3~3.8 (17~27)	3.5~5.8 (25~42)	4.1~6.8 (30~49)
M12×1.25	5.6~8.4 (41~61)	7.9~11.9 (57~86)	8.7~13.0 (63~94)
※M12×1.75	5.2~7.8 (38~56)	7.2~10.9 (52~79)	8.1~12.2 (59~88)
M14×1.5	8.5~12.7 (61~92)	11.7~17.6 (85~127)	12.6~18.9 (91~137)
※M14×2.0	7.9~11.8 (57~85)	11.1~16.6 (80~120)	11.8~17.7 (85~128)
M16×1.5	11.8~17.7 (85~128)	17.4~26.2 (126~190)	18.0~27.1 (130~196)
※M16×2.0	11.2~16.7 (81~121)	16.6~24.9 (120~180)	17.2~25.8 (124~187)

※ mark is used for female-threaded parts made of soft material, such as casting.

SECTION 1
GENERAL INFORMATION

TABLE OF CONTENTS

ITEM	PAGE
General repair instructions	1- 2
Notes on the format of this manual	1- 2
Main data and specifications	1- 6
Tightening torque specifications	1- 7

NOTICE

Before using this Workshop Manual to assist you in performing engine service and maintenance operations, it is recommended that you carefully read and thoroughly understand the information contained in Section - 1 under the headings "GENERAL REPAIR INSTRUCTION" and "NOTES ON THE FORMAT OF THIS MANUAL"

<https://www.ebooklibonline.com>

Hello dear friend!

Thank you very much for reading.

Enter the link into your browser.

The full manual is available for immediate download.

<https://www.ebooklibonline.com>

GENERAL REPAIR INSTRUCTIONS

1. Before performing any service operation with the engine mounted, disconnect the grounding cable from the battery.
This will reduce the chance of cable damage and burning due to short circuiting.
2. Always use the proper tool or tools for the job at hand.
Where specified, use the specially designed tool or tools.
3. Use genuine ISUZU parts.
4. Never reuse cotter pins, gaskets, O-rings, lock washers, and self locking nuts. Discard them as you remove them. Replace them with new ones.
5. Always keep disassembled parts neatly in groups. This will ensure a smooth reassembly operation.
It is especially important to keep fastening parts separate. These parts vary in hardness and design, depending on their installation position.
6. All parts should be carefully cleaned before inspection or reassembly.
Oil ports and other openings should be cleaned with compressed air to make sure that they are completely free of obstructions.
7. Rotating and sliding part surfaces should be lubricated with oil or grease before reassembly.
8. If necessary, use a sealer on gaskets to prevent leakage.
9. Nut and bolt torque specifications should be carefully followed.
10. Always release the air pressure from any machine-mounted air tank(s) before dismantling the engine or disconnecting pipes and hoses. To not do so is extremely dangerous.
11. Always check and recheck your work. No service operation is complete until you have done this.

NOTES ON THE FORMAT OF THIS MANUAL

This Workshop Manual is applicable to ISUZU industrial engine or engines which is or are stated in the title.

When more than two engine models are dealt in the manual, such engines have common parts and components as well as data and specifications, unless otherwise specified.

1. Find the applicable section by referring to the Table of Contents at the beginning of the Manual.
2. Common technical data such as general maintenance items, service specifications, and tightening torques are included in the "General Information" section.
The section ENGINE ASSEMBLY is an exception. This parts are divided in three sections to facilitates indexing.
3. Each section is divided into sub-sections dealing with disassembly, inspection and repair, and reassembly.

4. When the same servicing operation is applicable to several different units, the manual will direct you to the appropriate page.
5. For the sake of brevity, self-explanatory removal and installation procedures are omitted. More complex procedures are covered in detail.
6. Each service operation section in this Workshop Manual begins with an exploded view of the applicable area. A brief explanation of the notation used follows.

Disassembly Steps - 2

1. Water by-pass hose	10. Cylinder head gasket
2. Thermostat housing	▲ 11. Crankshaft damper pulley with dust seal
3. Water pump	12. Timing gear case cover
▲ 4. Injection nozzle holder	13. Timing gear cover
5. Glow plug and glow plug connector	14. Timing gear oil pipe
6. Cylinder head cover	15. Idler gear "B" and shaft
▲ 7. Rocker arm shaft and rocker arm	▲ 16. Idler gear "A"
8. Push rod	▲ 17. Idler gear shaft
▲ 9. Cylinder head	

Inverted Engine

Parts marked with an asterisk (*) are included in the repair kit.

Parts within a square frame are to be removed and installed as a single unit, and their disassembly steps or reassembly steps are shown in the illustrations respectively.

The number tells you the service operation sequence.

Removal of unnumbered parts is unnecessary unless replacement is required.

The "** Repair Kit" indicates that a repair kit is available.

The parts listed under "Disassembly Steps" or "Reassembly Steps" are in the service operation sequence.

The removal or installation of parts marked with a triangle (▲) is an important operation. Detailed information is given in the text.

1-4 GENERAL INFORMATION

7. Below is a sample of the text of the Workshop Manual.

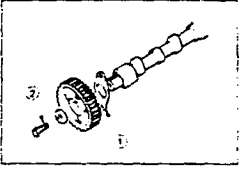

4. Camshaft Timing Gear

- 1) Install the thrust plate ①.
- 2) Apply engine oil to the bolt threads ②.
- 3) Install the camshaft timing gear with the timing mark stamped side facing out.

Camshaft Timing Gear Bolt Torque kg·m(lb. ft./N·m)

11.0 ± 1.0 (79.5 ± 7.2/107.8 ± 9.8)

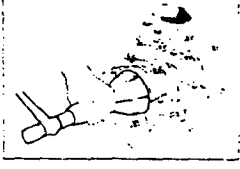

13. Crankshaft Rear Oil Seal

- 1) Apply engine oil to the oil seal lip circumference and the oil seal outer circumference.
- 2) Use the oil seal installer to install the oil seal to the cylinder body.

Oil Seal Installer: 5-8840-0141-0

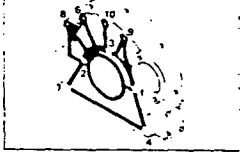

14. Flywheel Housing

- 1) Apply liquid gasket to the shaded area shown in the illustration.
- 2) Tighten the flywheel housing bolts to the specified torque a little at a time in the sequence shown in the illustration.

Flywheel Housing Bolt Torque kg·m(lb. ft./N·m)

M10×1.25 (0.40×0.05) Bolt	5.6±1.0 (40.5±7.2/ 54.9±9.8)
M12×1.25 (0.47×0.05) Bolt	10.5±1.0 (76.0±7.2/103.0±9.8)
M12×1.75 (0.47×0.07) Bolt	9.8±1.0 (71.0±7.2/ 96.0±9.8)

This is the item shown in the illustration. It is marked with a triangle (▲) on the Major Components page.

















Letters and numbers contained in a circle refer to the illustration.

Special tools are identified by the tool name and/or number. The illustration shows how the special tool is to be used.

Symbols indicate the type of service operation or step to be performed. A detailed explanation of these symbols follows.

Service data and specifications are given in this table.

8. The following symbols appear throughout this Workshop Manual. They tell you the type of service operation or step to perform.

	Removal		Adjustment
	Installation		Cleaning
	Disassembly		Important operation requiring extra care
	Reassembly		Specified torque (tighten)
	Alignment (marks)		Special tool use required or recommended (Isuzu tool or tools)
	Directional indication		Commercially available tool use required or recommended
	Inspection		Lubrication (oil)
	Measurement		Lubrication (grease)
				Liquid gasket application

9. Measurement criteria are defined by the terms "standard" and "limit".

A measurement falling within the "standard" range indicates that the applicable part or parts are serviceable.

"Limit" should be thought of as an absolute value.

A measurement which is outside the "limit" indicates that the applicable part or parts must be either repaired or replaced.

10. Components and parts are listed in the singular form throughout the Manual.

11. Directions used in this Manual are as follows:

Front

The cooling fan side of the engine viewed from the flywheel.

Right

The right hand side viewed from the same position.

Left

The left hand side viewed from the same position.

Rear

The flywheel side of the engine.

Cylinder numbers are counted from the front of the engine.

The front most cylinder is No. 1 and rear most cylinder is the final cylinder number of the engine.

The engine's direction of rotation is counterclockwise viewed from the flywheel.

MAIN DATA AND SPECIFICATIONS

Engine Model		4JA1	4JB1	4JC1
Item				
Engine type		Water cooled, four-cycle, in-line, overhead valve		
Combustion chamber type		Direct injection		
Cylinder liner type		Dry		
No. of cylinders - Bore x Stroke	mm(in.)	4-93.0x92.0 (3.66x3.62)	4-93.0x102.0 (3.66x4.02)	4-88.0x92.0 (3.46x3.62)
Total piston displacement	cm ³ (in ³)	2,449(152.4)	2,771(169.0)	2,238(136.5)
Compression ratio (To 1)		18.4	18.2	19.0
*Engine dimensions	mm(in.)	805x590x725	760x620x710	717x590x725
Length x Width x Height		(31.7x23.2x28.5)	(29.9x24.4x28.0)	(28.2x23.2x28.5)
*Engine weight (Dry)	kg(lb.)	218 (480)	240(529)	218 (480)
Fuel injection order		1-3-4-2		
*Fuel injection timing (B.T.D.C.)	degrees	17		
Specified fuel		Diesel fuel		
Injection pump		In-line plunger, Bosch A type		
Governor		Mechanical, RSV type		
*Low idle speed	rpm	980~1020		
Injection nozzle		Hole type (with 4 orifices)		
Injection starting pressure	kg/cm ² (psi)/kPa	185 (2630/18,142)		
Fuel filter type		Cartridge paper element		
Water sedimentor (if so equipped)		Sediment/water level indicating type		
Compression pressure	kg/cm ² (psi)/kPa	30(427/2,942)		
Valve clearance (at cold)	Intake mm(in.)	0.40 (0.016)		
	Exhaust mm(in.)	0.40 (0.016)		
Lubrication method		Pressurized circulation		
Oil pump		Trochoid type		
Main oil filter type		Cartridge paper element, full flow		
Partial oil filter		Not equipped		
*Lubricating oil capacity	lit.(US/UK gal.)	7(1.85/1.54)		
Oil cooler (if so equipped)		Water cooled built in oil filter		
Cooling method		Pressurized forced circulation		
Coolant capacity (Total)	lit.(US/UK gal.)	12(3.17/2.64)		
Water pump		Belt driven impeller type		
Thermostat type		Wax pellet type		
*Alternator	V-A	24-30		
*Starter	V-kW	24-3.2		

Specifications marked with an asterisk (*) will vary according to engine application.

TIGHTENING TORQUE SPECIFICATION



STANDARD BOLTS

The torque values given in the following table should be applied where a particular torque is not specified.

kg·m(lb.ft./N·m)

Bolt identification Bolt diameter x pitch (mm)			
	4T (Low carbon steel)	7T (High carbon steel)	9T (Alloy steel)
M 6 x 1.0	0.6 ± 0.2 (4.4 ± 1.4 / 5.88± 1.96)	0.75± 0.2 (5.43± 1.43/ 7.35± 1.96)	—
M 8 x 1.25	1.3 ± 0.5 (0.4 ± 3.4 / 12.74± 4.90)	1.75± 0.5 (12.66± 3.00/ 17.15± 4.90)	2.0 ± 0.7 (17.36± 5.36/ 19.60± 6.86)
M10 x 1.25	2.8 ± 0.7 (20.3 ± 5.2 / 27.44± 6.86)	3.75± 0.9 (27.20± 7.2 / 36.75± 8.82)	5.0 ± 1.3 (36.88± 9.88/ 49.00± 12.74)
M12 x 1.25	6.25± 1.2 (45.2 ± 9.2 / 61.25± 11.76)	7.75± 1.5 (56.03± 11.03/ 75.95± 14.70)	9.65± 1.9 (69.77± 13.77/ 94.57± 18.62)
M14 x 1.5	8.75± 1.9 (70.5 ± 14.5 / 85.75± 18.62)	11.85± 2.3 (85.67± 16.6 /116.13± 22.54)	14.5 ± 2.9 (104.84± 20.83/142.1 ± 28.42)
M16 x 1.5	13.3 ± 2.7 (94.0 ± 17.0 /130.34± 26.46)	17.35± 3.5 (125.07± 25.07/169.54± 34.30)	20.4 ± 4.1 (147.5 ± 29.49/199.92± 40.18)
M18 x 1.5	19.2 ± 3.8 (138.9 ± 27.9 /188.16± 37.24)	24.90± 5.0 (180.03± 36.3 /244.02± 4.90)	29.30± 5.9 (211.84± 42.83/287.14± 57.82)
M20 x 1.5	26.3 ± 5.3 (190.2 ± 38.2 /257.74± 51.94)	34.40± 6.9 (248.72± 49.7 /337.12± 67.62)	40.40± 8.1 (292.10± 58.09/395.92± 79.38)
M22 x 1.5	33.0 ± 8.3 (245.1 ± 60.1 /323.40± 81.34)	46.25± 9.2 (334.39± 66.38/453.25± 90.16)	54.10±10.8 (391.15± 78.14/530.18±105.84)
M24 x 2.0	45.8 ± 9.2 (331.2 ± 60.2 /448.84± 90.16)	58.20±14.0 (420.70±102.78/570.36±137.20)	70.60±14.1 (510.44±101.44/691.88±138.18)
*M10 x 1.5	2.7 ± 0.7 (19.6 ± 5.6 / 26.46± 6.86)	3.7 ± 0.9 (26.75± 6.7 / 36.26± 8.82)	4.9 ± 1.2 (35.43± 8.42/ 48.02± 11.76)
*M12 x 1.5	5.8 ± 1.2 (42.0 ± 9.0 / 56.84± 11.76)	7.2 ± 1.4 (52.02± 10.05/ 70.56± 13.72)	9.1 ± 1.8 (65.80± 12.80/ 89.18± 17.64)
*M14 x 2.0	9.1 ± 1.8 (65.8 ± 12.8 / 89.18± 17.64)	11.2 ± 2.2 (80.97± 15.7 /109.76± 21.56)	13.6 ± 2.7 (98.33± 19.33/133.28± 26.46)
*M16 x 2.0	12.7 ± 2.5 (91.9 ± 17.9 /124.46± 24.5)	16.5 ± 3.3 (119.30± 24.3 /161.70± 32.34)	19.5 ± 3.9 (140.99± 27.99/191.1 ± 38.22)

Note:

The asterisk (*) indicates that the bolts are used for female-threaded parts that are made of soft materials such as casting.



SPECIAL PARTS FIXING NUTS AND BOLTS

Cylinder Head Cover, Cylinder Head, and Rocker Arm Shaft Bracket

kg·m(lb.ft./N·m)

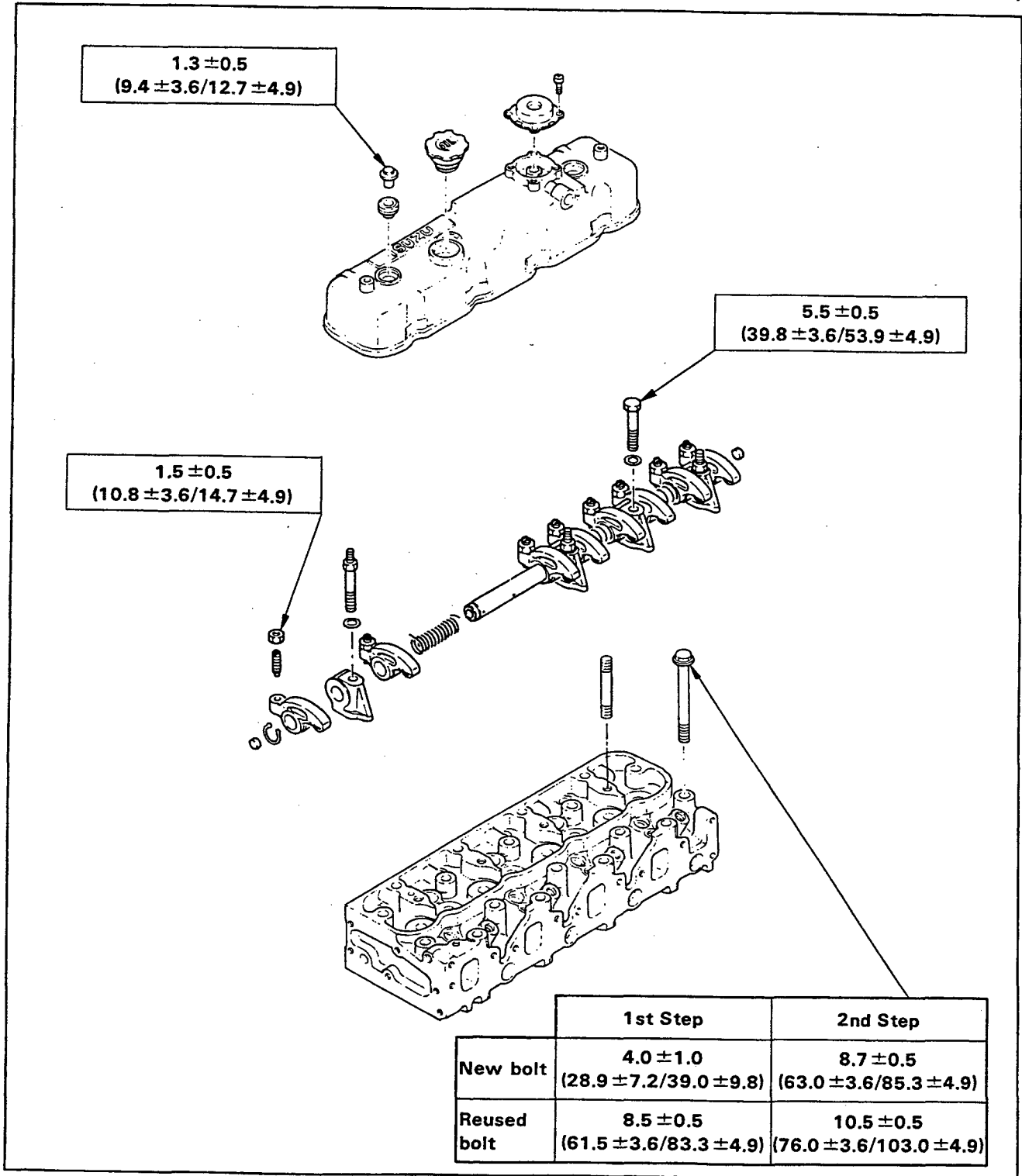



**Crankshaft Bearing Cap, Connecting Rod Bearing Cap,
Crankshaft Damper Pulley, Flywheel, and Oil Pan**

kg·m(lb.ft./N·m)

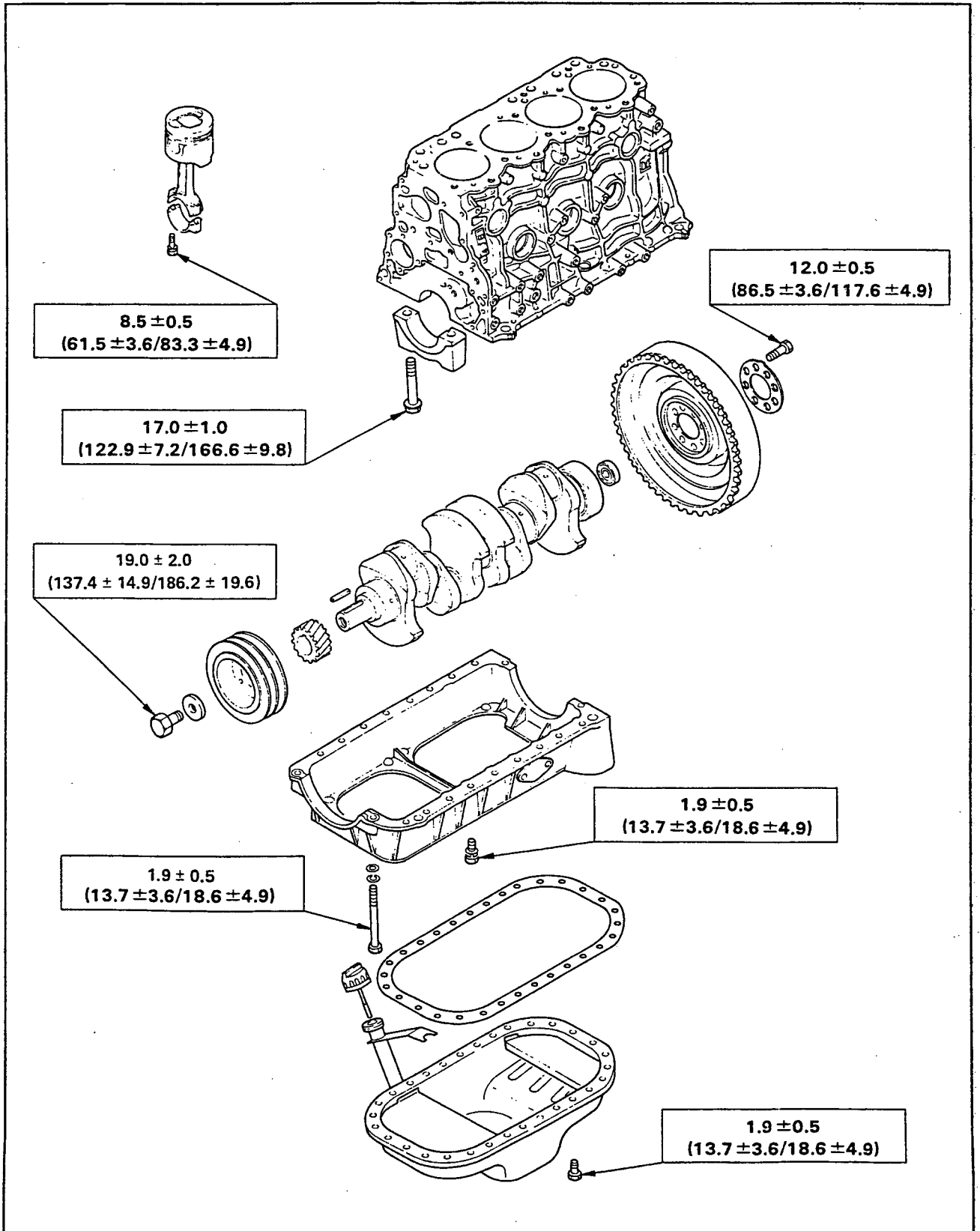



Timing Gear Case, Flywheel Housing, Camshaft, and Timing Gear

kg-m(lb.ft./N-m)

M10x1.25 (0.39x0.05)	5.6 ± 1.0 (40.5 ± 7.2/54.9 ± 9.8)
M10x1.25 (0.39x0.05)	1.6 ± 1.0 (75.9 ± 7.2/102.7 ± 9.8)
M12x1.75 (0.47x0.07)	9.8 ± 1.0 (70.9 ± 7.2/96.0 ± 9.8)

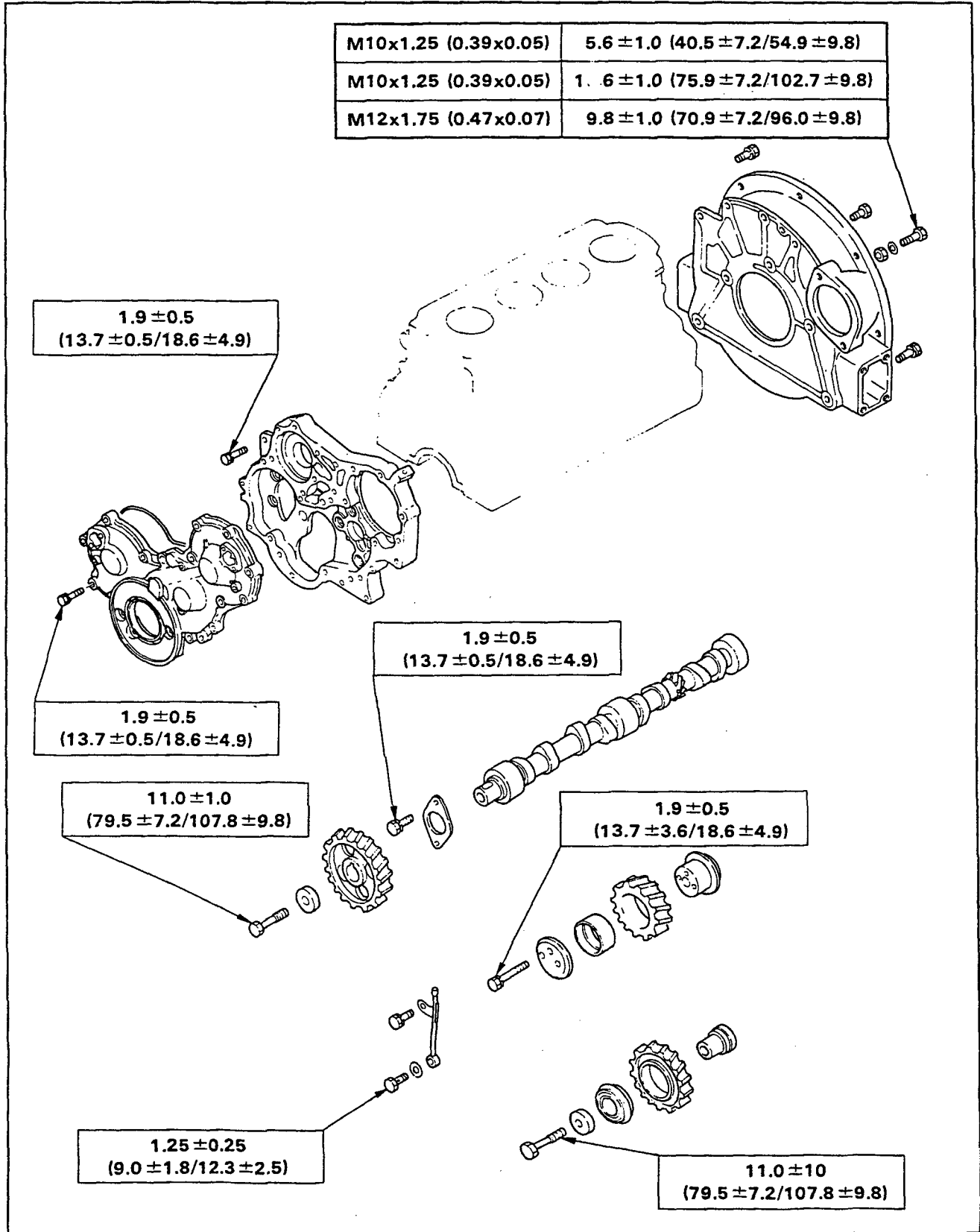



Cooling and Lubricating System

kg-m(lb.ft./N-m)

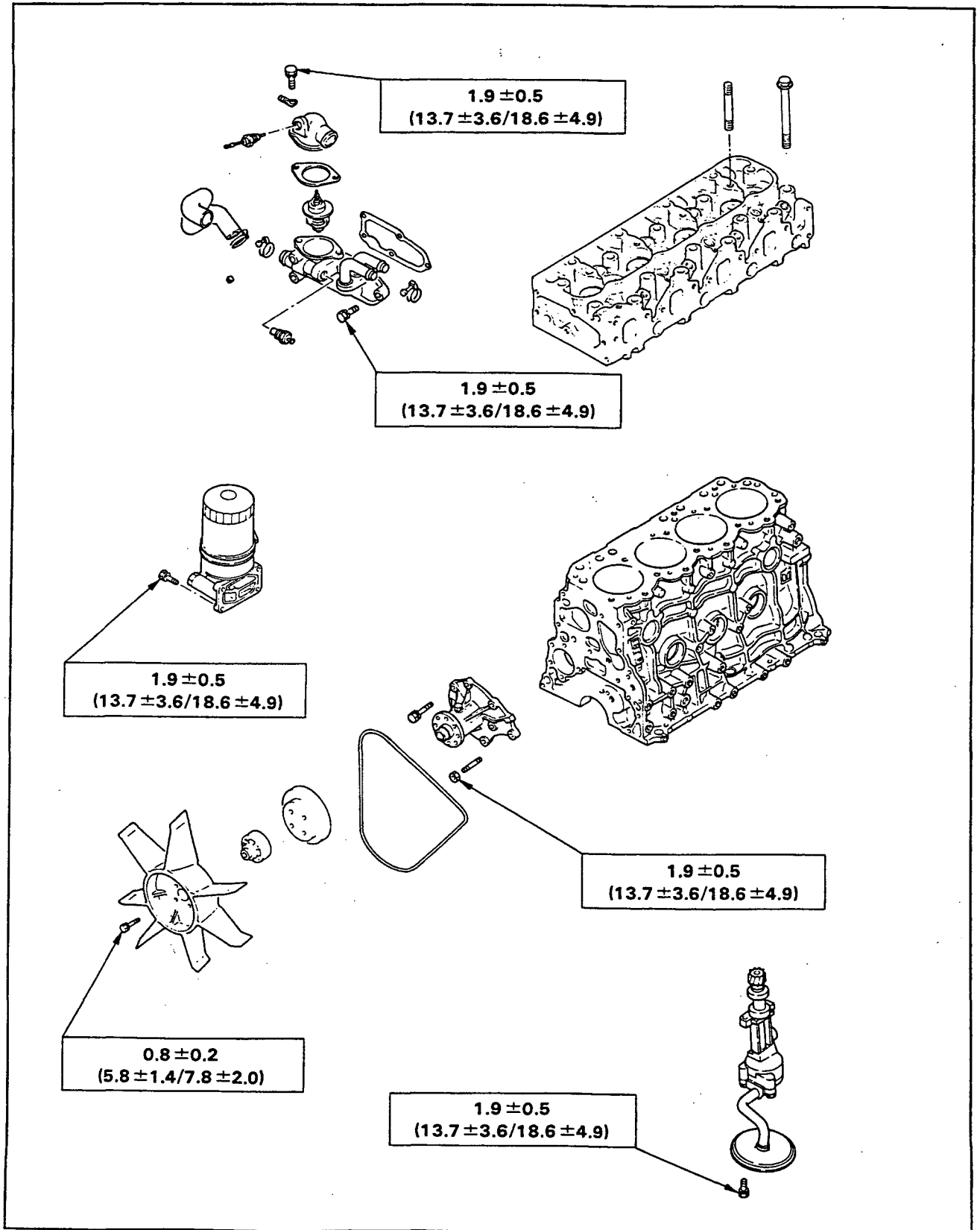



Intake and Exhaust Manifold

kg·m(lb.ft./N·m)

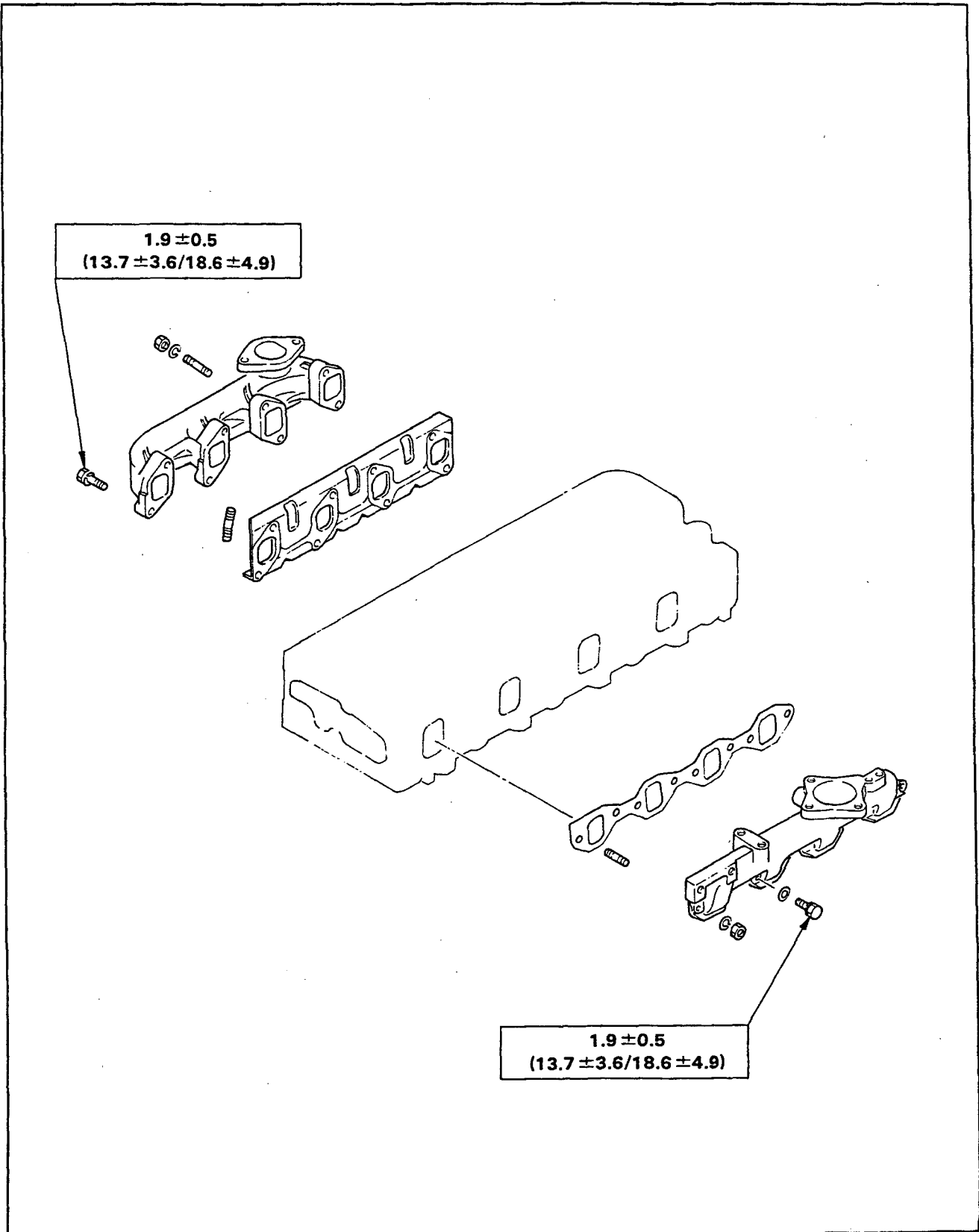



Engine Electrical

kg-m(lb.ft./N-m)

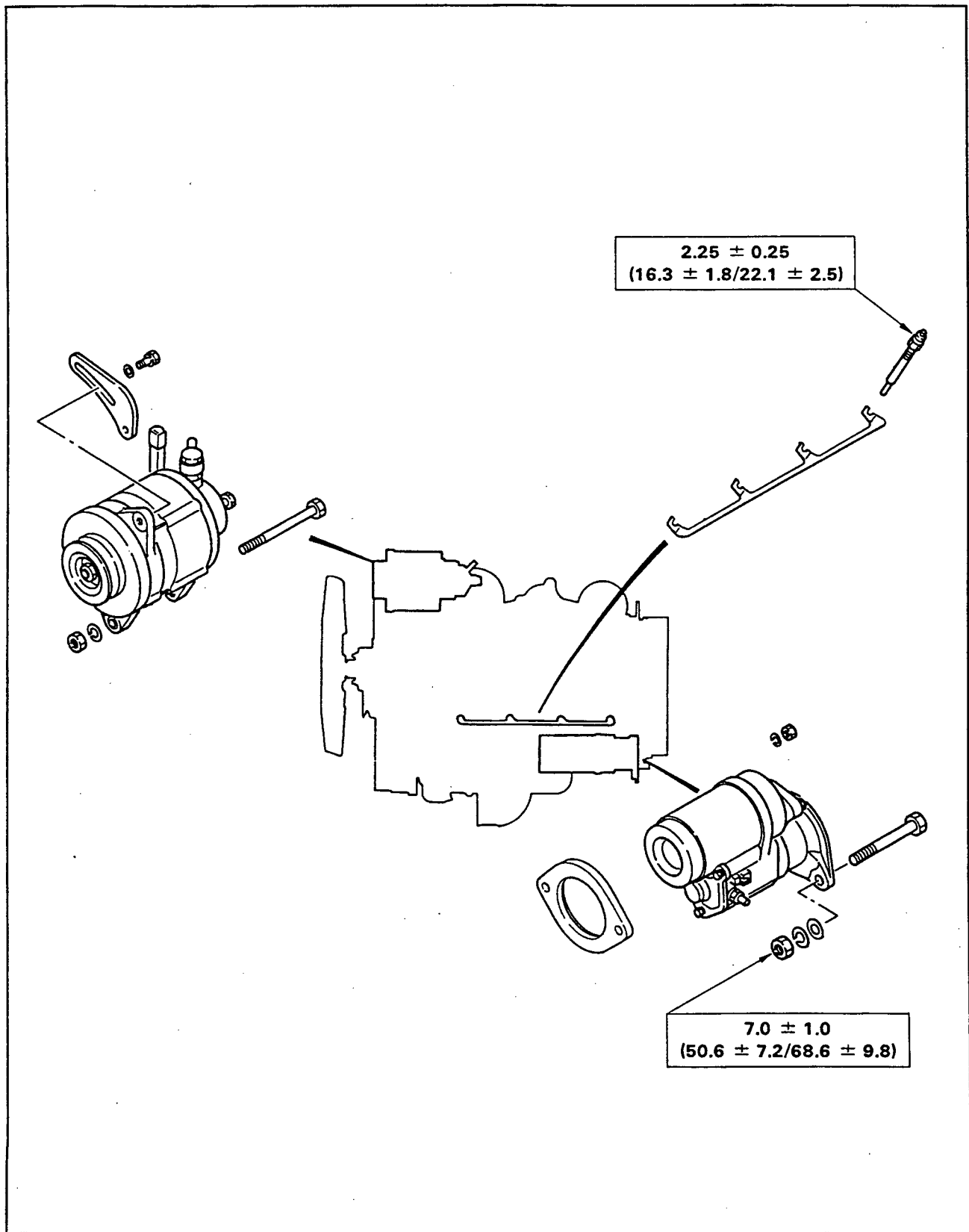



Fuel Injection System

kg-m(lb.ft./N-m)

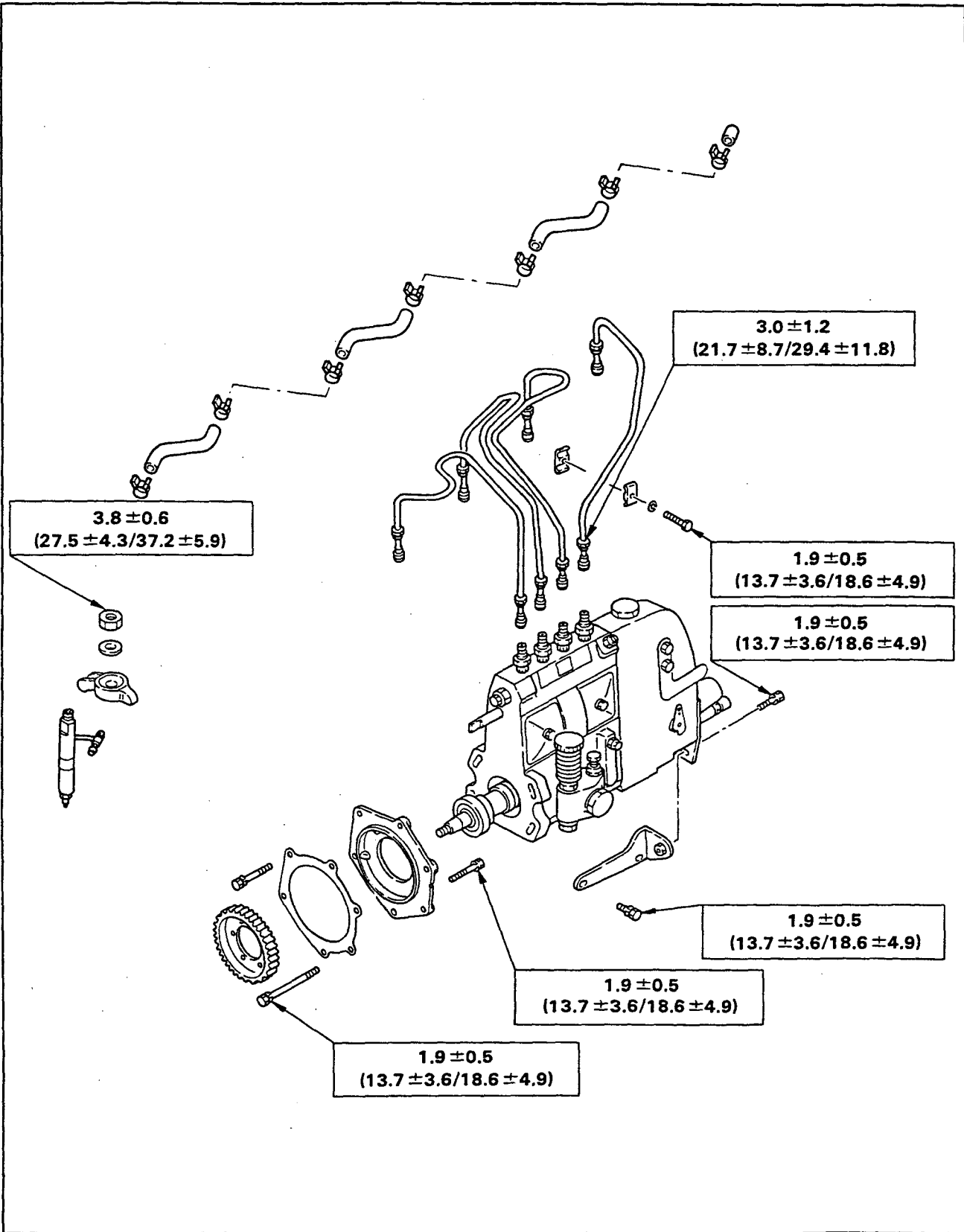

SECTION 2

MAINTENANCE

TABLE OF CONTENTS

ITEM	PAGE
Model identification	2- 2
Injection pump identification	2- 2
Lubricating system	2- 2
Fuel system	2- 3
Cooling system	2- 6
Valve clearance adjustment	2- 7
Injection timing	2- 8
Compression pressure measurement	2- 9
Recommended lubricants	2-10
Repair kits	2-11



Suggest:

For more complete manuals. Please go to the home page.

<https://www.ebooklibonline.com>

If the above button click is invalid. Please download this document first, and then click the above link to download the complete manual.

Thank you so much for reading

MAINTENANCE

Servicing refers to general maintenance procedures to be performed by qualified service personnel. Maintenance interval such as fuel or oil filter changes should be referred to "INSTRUCTION MANUAL".

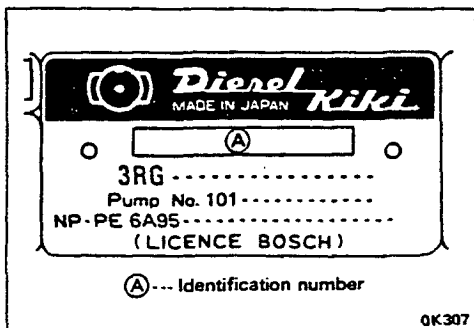
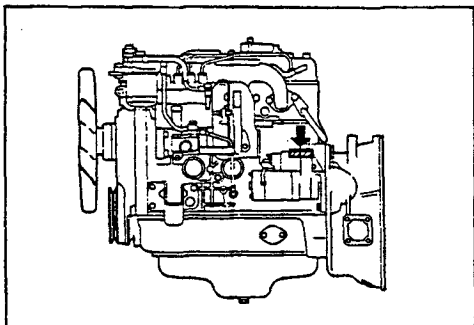

MODEL IDENTIFICATION

Engine Serial Number

The engine number is stamped on the rear left hand side of the cylinder body.

INJECTION PUMP IDENTIFICATION

Injection volume should be adjusted after referring to the adjustment data applicable to the injection pump installed.

The injection pump identification number (A) is stamped on the injection pump identifications plate.

Note:

Always check the identification number before beginning a service operation.

Applicable service data will vary according to the identification number. Use of the wrong service data will result in reduced engine performance and engine damage.

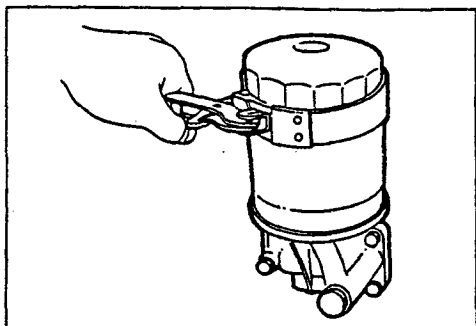

LUBRICATING SYSTEM

Main Oil Filter

Replacement Procedure

1. Loosen the drain plug to drain the engine oil.
2. Wait a few minutes and then retighten the drain plug.
3. Loosen the used oil filter by turning it counterclockwise with a filter wrench.

Filter Wrench



4. Clean the oil cooler fitting face.
This will allow the new oil filter to seat properly.
5. Apply a light coat of engine oil to the O-ring.
6. Turn in the new oil filter until the filter O-ring is fitted against the sealing face.

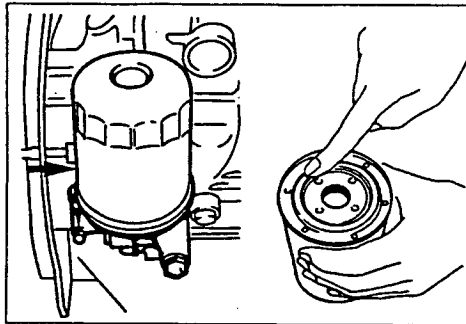

7. Use a filter wrench to turn in the filter an additional 1 and 1/4 turns.

Filter Wrench

8. Check the engine oil level and replenish to the specified level if required.



9. Start the engine and check for oil leakage from the main oil filter.

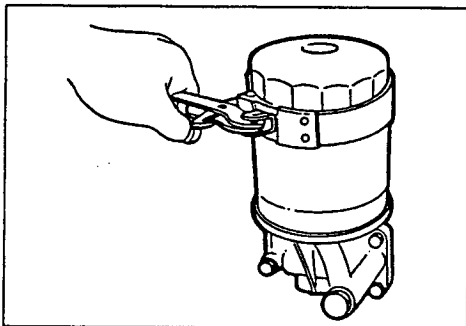

FUEL SYSTEM

Fuel Filter

Replacement Procedure



1. Loosen the used fuel filter by turning it counterclockwise with the filter wrench.

Filter Wrench

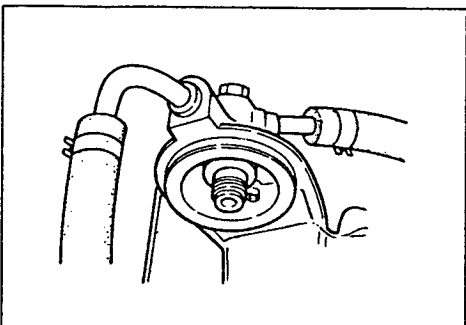

2. Clean the upper cover fitting face.
This will allow the new fuel filter to seat properly.

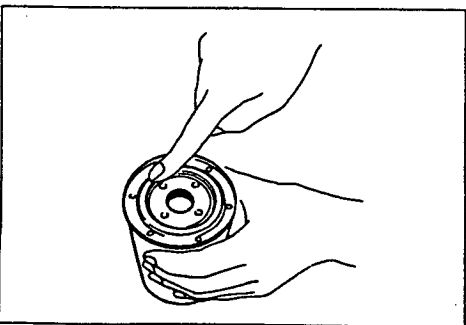

3. Apply a light coat of engine oil to the O-ring.
4. Supply fuel to the new fuel filter to facilitate bleeding.
5. Turn in the new fuel filter until the filter O-ring is fitted against the sealing face.
Be very careful to avoid fuel spillage.



6. Use a filter wrench to turn in the fuel filter an additional 1/3 to 2/3 of a turn.

<https://www.ebooklibonline.com>

Hello dear friend!

Thank you very much for reading.

Enter the link into your browser.

The full manual is available for immediate download.

<https://www.ebooklibonline.com>