

HINO DIESEL ENGINE WORKSHOP MANUAL

J08E-UV



(Shovel)

KSS-Z4J8-002E

2011.2

GENERAL	1
STANDARD VALUE	2
PARTS TO BE PREPARED	3
ENGINE MOUNTING/DISMOUNTING	4
FUEL SYSTEM	5
EMISSION CONTROL	6
ELECTRICAL	7
INTAKE	8
ENGINE MECHANICAL	9
EXHAUST	10
COOLING	11
LUBRICATION	12
STARTING AND CHARGING	13
TURBOCHARGER	14
AIR COMPRESSOR	15
FAILURE DIAGNOSIS FOR EACH ENGINE STATUS	16
ENGINE DIAGNOSIS CODE	17

For your information:

This documentation does not contain any descriptions in regard to the hatched part

"15. Air Compressors".

1 GENERAL

Warning.....	1-2
How to read this manual	1-3
Precautions for work	1-8
Tightening of engine bolts and nuts	1-12
Tightening of flare nuts and hoses.....	1-14
Taper thread sealant for piping	1-15
Assembly of joints and gaskets for piping	1-16
Handling of liquid gasket.....	1-18
Failure diagnosis table for each problem	1-19
Failure diagnosis procedures	1-20
Failure diagnosis using HinoDX.....	1-22
Connection method of HinoDX	1-26
Engine number	1-27

<https://www.ebooklibonline.com>

Hello dear friend!

Thank you very much for reading.

Enter the link into your browser.

The full manual is available for immediate download.

<https://www.ebooklibonline.com>

Warning

JP30ZCE010102001

Observe the following precautions to work safely and to prevent damage to customers' machine.

This manual is prepared for qualified service engineers who are recognized as technical expert. Those who are not qualified, who are not appropriately trained, who performs service without appropriate tool or equipment, or who perform service with the way not specified in this manual may not only damage the vehicle, but also put service engineers and surrounding people in danger.

- Appropriate service and repair are essential to ensure safety of service engineers and safety and reliability of vehicles. Be sure to use Hino genuine parts for replacement of parts. Do not use deteriorated parts in quality.
- Items described in this manual are the procedures to be observed in service and repair. For service and repair according to this procedure, be sure to use the special tools designed for each purpose.
- If a method or a tool not recommended is used, safety of service engineers, and safety and reliability of vehicles may be impaired. Never use a method or tool not recommended.
- This manual shows “Warning” and “Caution” for items that need to be observed so that accidents may not occur during service or repair, or that damage to vehicle due to improper method may not impair safety and reliability of vehicles. These instructions cannot give warning for all possible hazards. Note that items with “Warning” or “Caution” are not absolute for safety.

How to read this manual

JP30ZCE010102002

1. Scope of repair work

- (1) Repair work is classified into three large categories of "Diagnosis", "Mounting/removal, replacement, assembly-disassembly and inspection-adjustment" and "Final inspection".
- (2) This manual describes "Diagnosis" in the first process and "Mounting/removal, replacement, assembly-disassembly and inspection-adjustment" in the second process. Explanation of "Final inspection" in the third process is omitted here.
- (3) Although the following work is not described in this manual, it should be performed in actual work.
 - a. Jacking and lifting
 - b. Cleaning and washing of removed parts as required
 - c. Visual inspection

2. Standard value

- (1) Standard value, limit, action and tightening torque described in the text are summarized in tables.

3. Items to be prepared

- (1) Items to be prepared before work are SST, tools, gauges and lubricant, etc. These are listed in the list section of items to be prepared. Items such as general tools, jack, rigid rack, etc. that are usually equipped in general service shop are omitted.

4. How to read sections and titles

- (1) Sections are classified according to J2008, SAE standard.
- (2) For areas that show system names like "Engine control system", "Inspection", "Adjustment", "Replacement", "Overhaul", etc. of components are described.
- (3) For areas that show part names like "Injection pump", "Mounting/removal and disassembly" is described.
- (4) Illustrations of the parts catalog are shown for part layout. (Part codes in the parts catalog are described in the illustration. Major names and tightening torque are listed in the table.)

 **CAUTION** • **The part layouts in this manual are inserted based on illustrations and part numbers of the parts catalog CD-ROM issued in June, 2010. (Some areas do not show exploded view. They will be additionally issued when the parts catalog CD is revised.) Be sure to use the parts catalog for confirmation of illustrations and part numbers and for ordering parts.**

5. How to read troubleshooting

(1) Failure diagnosis in this manual describes Step 2 and Step 3 below :

(1) Question	"Step 1"	Hear from customers for conditions and environments of failures and check the fact.
(2) Pre-inspection (3) Reproduction method	"Step 2"	Perform diagnosis inspection, status inspection, function inspection and basic inspection. Check the failure status. If it is difficult to reproduce the problem with status inspection, use the reproduction method.
(4) Troubleshooting for each diagnosis code (5) Troubleshooting for each failure status	"Step 3"	Summarize inspection results obtained from Step 2. Perform inspection systematically according to troubleshooting procedures for each diagnosis code or failure status.
(6) Confirmation test	"Step 4"	Check if failure occurs again after repair. If it is difficult to reproduce a failure, perform the confirmation test under the conditions and environment of the failure.

(2) Pre-inspection

Pre-inspection	<ul style="list-style-type: none"> • Pre-inspection is performed in the following steps : Diagnosis inspection → Diagnosis deletion → Failure status check (Use the reproduction method if not reproduced.) → Diagnosis reconfirmation • Estimate the failure system before the reproduction test. Attach a tester and evaluate estimated failure together with failure status. Refer to the troubleshooting chart for estimated cause of a failure. • An error code is displayed if a failure occurs instantaneously. If any specific failure is not found, perform troubleshooting using the reproduction method. • Failure status check If failure is reproduced, perform Step 2 → Step 3 → Step 4. If failure is not reproduced, use the reproduction method (simulation of external conditions or check of each wire harness and connector, etc.)
-----------------------	---

6. How to read explanation details

(1) Part layout

Example

ENGINE MECHANICAL [J08E]

9-17

Timing Gear Cover and Flywheel Housing

Part layout

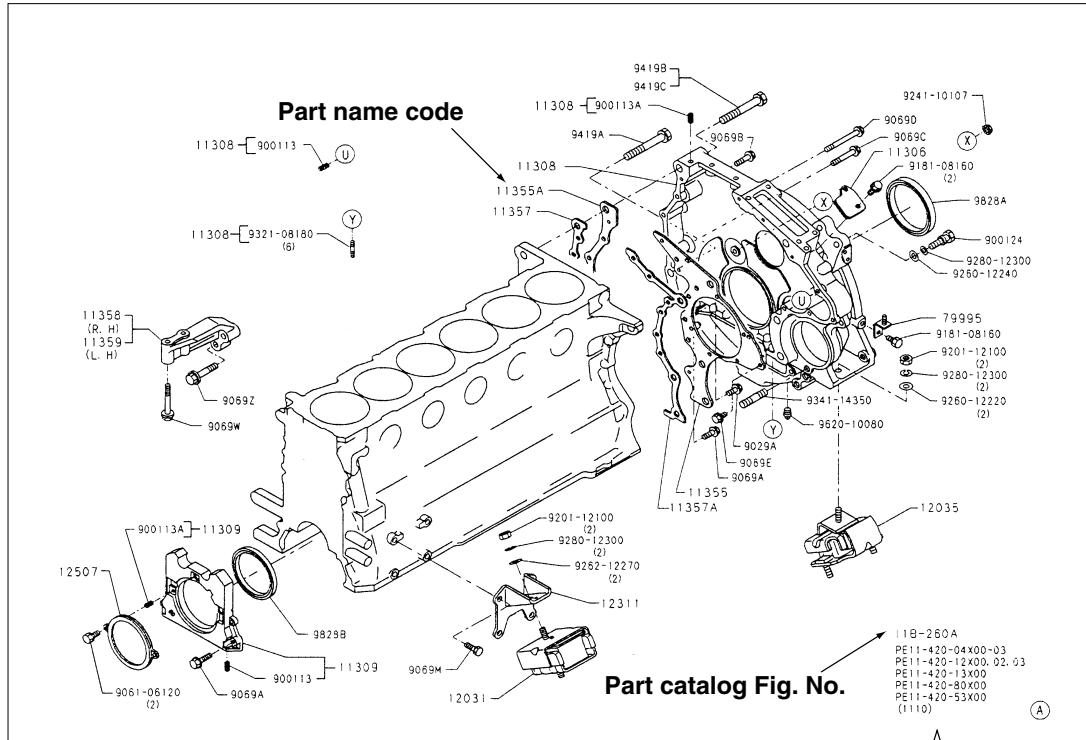

11308	Flywheel housing	11390	End plate
11309	Oil seal retainer	9828A	Front oil seal*
11357	Gasket*	9828B	Rear oil seal*
11357A	Gasket*		

*Parts not to be reused.

Left: Part name code (nut)

Tightening torque

9069H	M14 : 171.5N m{1, 750kgf cm}	9419A	M16 : 196N m{2, 000kgf cm}
9069J	M12 : 97N m{990kgf cm}	9419B	M16 : 196N m{2, 000kgf cm}

☆ It is the ID number for parts to prepare electronic data. It is not required for repair work.

7. Definition of terms

Terms in this manual are defined as follows :

- (1) Direction (Individual unit)
 - Front/back direction
The power input side is front and the output side is back.
 - Rotating direction
When viewed from the rear, the clockwise direction is right rotation and the counterclockwise direction is left rotation.
 - Vertical direction
With a unit mounted on the machine main unit, the upward direction is upper and the downward direction is lower.
 - Left/right direction
When viewed from the rear, the left direction is left and the right direction is right.
- (2) Standard valueBasic dimension excluding tolerance and clearance generated by tolerances when two parts are joined
- (3) Repair limit...It is the value requiring repair. Symbol of + or - with the value means increase or decrease to the standard value.
- (4) Operation limit...It is the value requiring replacement. Symbol of + or - with the value means increase or decrease to the standard value.
- (5) Warning.....It is an item that may result in risk of human life or serious injury by incorrect handling.
- (6) Caution.....It is an item that should not be performed including inhibited work or an item that require attention in working procedures.
- (7) Reference.....It is supplementary explanation in work.

8. Unit

- (1) SI unit is used in this manual. SI unit is the international unit to unify the conventional different international units into one unit per quantity and to promote smooth technical communications.
- (2) This manual shows both the SI unit and conventional units. The conventional units are shown in { }.

Item	SI unit	Conventional unit	Conversion value ^{*1} (1[Conventional unit] = X [SI unit])
Force	N	kgf	1kgf=9.80665N
Torque ^{*2}	N·m	kgf·cm	1kgf·cm=0.0980665N·m
Pressure	Pa	kgf/cm ²	1kgf/cm ² =98.0665kPa =0.0980665MPa
		mmHg	1mmHg=0.133322kPa
Rotational speed	r/min	rpm	1rpm=1r/min
	min ⁻¹		1rpm=1min ⁻¹
Spring constant	N/mm	kgf/mm	1kgf/mm=980665N/mm
Volume	L	cc	1cc=1mL
Efficiency	W	PS	1PS=0.735499kW
Calorific value	W·h	cal	1kcal=1.13279W·h
Fuel consumption rate	g/W·h	g/PS·h	1g/PS·h=1.3596g/kW·h

^{*1} : X means the value when 1 [Conventional unit] is converted to the SI unit.

It is used as the conversion factor from the conventional unit to the SI unit.

^{*2} : The conversion value of the torque may vary depending on the unit.

Observe the standard values described for each unit.

Precautions for work

JP30ZCE0101001

1. General precautions

To ensure safety in work and to prevent accidents, observe the following items :

- (1) Appearance
 - a. Wear safety goggles.
 - b. Do not wear watch, necktie, ring, bracelet, necklace, etc. to prevent accident before work.
 - c. Bind long hair at the back.
 - d. Be sure to wear a cap and safety shoes.
- (2) Safety work
 - a. Do not touch radiator, muffler, exhaust pipe, tail pipe, etc. after stop of the engine to prevent burn.
 - b. Do not put your clothes or tools near the rotating part (in particular, cooling fan or V-belt) during operation of the engine.
 - c. Remove the starter key when the engine is not started.
 - d. Start the engine at a well ventilated place so that carbon monoxide may not be filled.
 - e. Since gas from the fuel or the battery is flammable, do not spark a fire or smoke a cigarette near the area.
 - f. Since the battery fluid is poisonous and corrosive, be careful for handling.
 - g. Do not short-circuit the cable of the battery or starter. Otherwise, the cable may be burned or burn may occur.
 - h. If a tool or rag is left in the engine compartment, it may be bounced with a rotating part of the engine, resulting in injury.
 - i. To tow a failure machine, refer to "Towing" in the "Operation manual" of the machine.

2. Precautions for service work

Pay attention to the following points before service work

- (1) Preparation before disassembly
 - a. Prepare general tools, special tools and gauges before work.
 - b. To disassemble a complicated area, put a stamp or match mark on the location not functionally affected to ease assembly. To repair the electric system, disconnect the cable from the minus terminal of the battery before work.
 - c. Perform inspection according to the procedure in the text before disassembly.
- (2) Inspection during disassembly
Every time parts are removed, check the area where the parts are assembled and check for deformation, damage, wear or scratch.
- (3) Arrangement of disassembled parts
Place removed parts neatly in order. Separate parts to be replaced from parts to be reused.
- (4) Washing of disassembled parts
Clean and wash parts to be reused well.
- (5) Inspection and measurement
Inspect and measure parts to be reused as required.
- (6) Assembly
 - a. Keep the specified standard values (tightening torque, adjusting values, etc.) and assemble correct parts in the correct order.
 - b. Be sure to use genuine parts for parts to be replaced.
 - c. Use new packing, gasket, O-ring and cotter pin.
 - d. Use seal gaskets for some areas where gaskets are used. Apply specified oil or grease to sliding areas where application of oil is required, and apply specified grease to the oil seal lip before assembly.
- (7) Check of adjustment
Make adjustments to the service standard values using a gauge or tester.

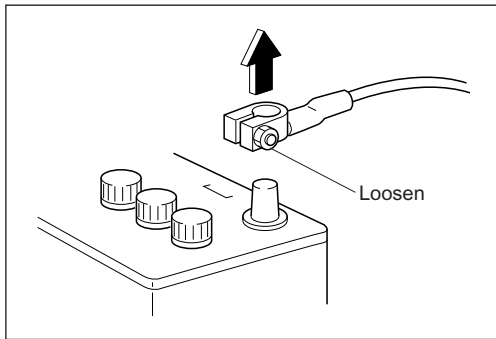

SAPH30ZCE0100002

3. Precautions for electric system

(1) Removal of battery cable

- a. In an electric system, remove the cable from the battery minus (-) terminal to prevent burnout due to short-circuit.
- b. When the battery cable is removed, the battery terminal may be damaged. Loosen the nut completely and never pry it for removal.

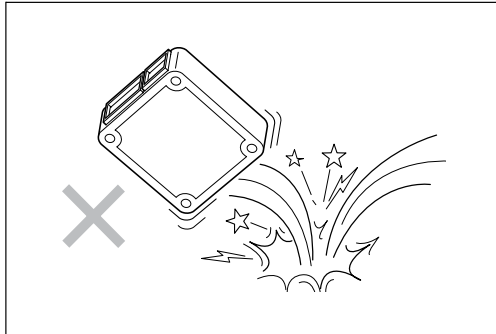

SAPH30ZCE0100003

(2) Handling of electronic parts

- a. Do not give impact on electronic parts such as computer and relay.
- b. Do not place electronic parts at a high temperature and humidity area.
- c. Do not expose electronic parts to water in washing of a vehicle.

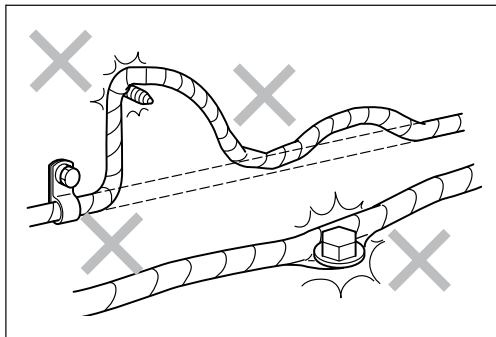

SAPH30ZCE0100004

(3) Handling of wire harness

- a. Mark clamps and clips to prevent interference of a wire harness with body edge, sharp edge and bolts. Be sure to reassemble it to the original position.
- b. When parts are assembled, be careful not to pinch a wire harness.

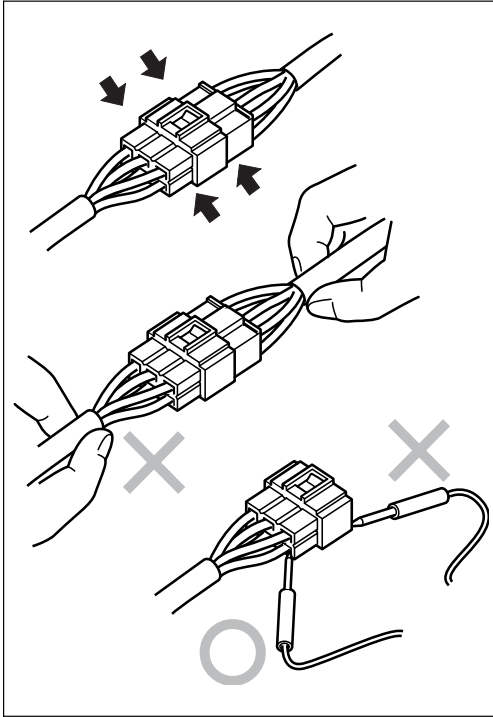

SAPH30ZCE0100005

(4) Handling of connector

- a. When a connector is removed, hold the connector (as shown by the arrow in the left) and pull it out. Do not pull the wire harness.
- b. Unlock the locking connector before pulling.
- c. Insert the locking connector completely until it clicks.
- d. To insert a test lead into the connector, insert it from the back of the connector.
- e. If it is difficult to insert a test lead from the back of the connector, prepare a harness for inspection.

4. Precautions for electric welding

Inadvertent electric welding on a cab or frame may cause reverse welding current from the grounding circuit, resulting in damage to electric and electronic parts. Observe the following items for electric welding.

- (1) Turn "OFF" the starter switch.
- (2) Make sure that switches are "OFF".
- (3) Disconnect the minus (-) terminal of the battery according to the removal procedure of the battery cable.
- (4) Disconnect connectors of each computer.
- (5) Remove all fuses. (For locations of fuses, refer to "Electrical Chapter".)
- (6) Be sure to connect grounding of the electric welding machine near the welding area.
Connect grounding from a bolt (plated bolt) or a frame near the welding area.
Remove paint of the frame for connection of grounding from the frame.
The seal and the bearing etc. that please make sure do not enter between the weld and the ground section.
- (7) Other precautions
 - a. Put a cover on rubber hoses, wire harnesses, pipes, tires, etc. around the welding area so that they may not be exposed to spatter.
 - b. Perform welding under appropriate conditions and minimize heat effect in the peripheral area. Also maintain welding quality.
- (8) After welding, connect and assemble in the order of the fuse and the minus terminal of the battery disassembled. When paint is removed from a frame or cab, apply rust preventive coating with the same color.
- (9) After reassembly, check the function if it operates correctly.

Tightening of engine bolts and nuts

JP30ZCE010102003

1. Tightening torque of general standard bolts

(1) For bolts with seatings

Unit : N·m{kgf·cm, lbf·ft}

Screw diameter x Pitch	7T	9T
M8 x 1.25 (Coarse thread)	28.5 {290, 21}	36 {370, 27}
M10 x 1.25 (Fine thread)	60 {610, 44}	74.5 {760, 55}
M10 x 1.5 (Coarse thread)	55 {560, 41}	68.5 {700, 51}
M12 x 1.25 (Fine thread)	108 {1100, 80}	136 {1390, 101}
M12 x 1.75 (Coarse thread)	97 {990, 72}	125 {1280, 93}
M14 x 1.5 (Fine thread)	171.5 {1750, 127}	216 {2210, 160}
M14 x 2 (Coarse thread)	154 {1570, 114}	199 {2030, 147}
Remark	Bolt with number "7" on the head	Bolt with number "9" on the head

⚠ CAUTION • 8T bolt is in accordance with 7T bolt.

(2) For bolts with washers

Unit : N·m{kgf·cm, lbf·ft}

Screw diameter x Pitch	4T	7T	9T
M6 x 1 (Coarse thread)	6 {60, 4}	10 {100, 7}	13 {130, 9}
M8 x 1.25 (Coarse thread)	14 {140, 10}	25 {250, 18}	31 {320, 23}
M10 x 1.25 (Fine thread)	29 {300, 22}	51 {520, 38}	64 {650, 47}
M10 x 1.5 (Coarse thread)	26 {270, 20}	47 {480, 35}	59 {600, 43}
M12 x 1.25 (Fine thread)	54 {550, 40}	93 {950, 69}	118 {1200, 88}
M12 x 1.75 (Coarse thread)	49 {500, 36}	83 {850, 61}	108 {1100, 80}
M14 x 1.5 (Fine thread)	83 {850, 61}	147 {1500, 108}	186 {1900, 137}
M14 x 2 (Coarse thread)	74 {750, 54}	132 {1350, 98}	172 {1750, 127}
Remark	Bolt with number "4" on the head Projection bolt Stud with R surface at free end	Bolt with number "7" on the head Stud with C surface at free end	Bolt with number "9" on the head

⚠ CAUTION • 8T bolt is in accordance with 7T bolt.

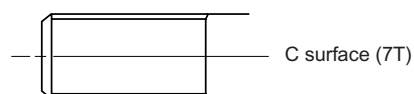
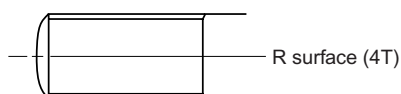

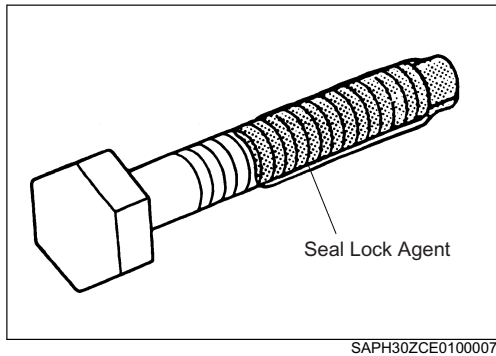

SAPH30ZCE0100007

2. Precoated bolt

Precoated bolt is the bolt with application of seal lock agent at the thread.

- (1) When re-application of lock agent is required
 - a. When precoated bolts are removed
 - b. When precoated bolts are moved due to tightening check (for loosening or tightening)

NOTICE

- **Check torque with the lower limit of the tightening torque allowable value. If movement is found, tighten the bolt according to the procedure below.**

- (2) Re-use method of precoated bolt lock
 - a. Clean bolt and screw holes. (Clean screw holes for replacement.)
 - b. Dry completely by blowing air.
 - c. Apply the specified seal lock agent to the thread of the bolt.

3. Plastic region tightening method (angle method)

- CAUTION**
- **Some engines are tightened with the plastic region tightening method.**
 - **Since it is different from the conventional method, tighten it according to the instruction in the text.**

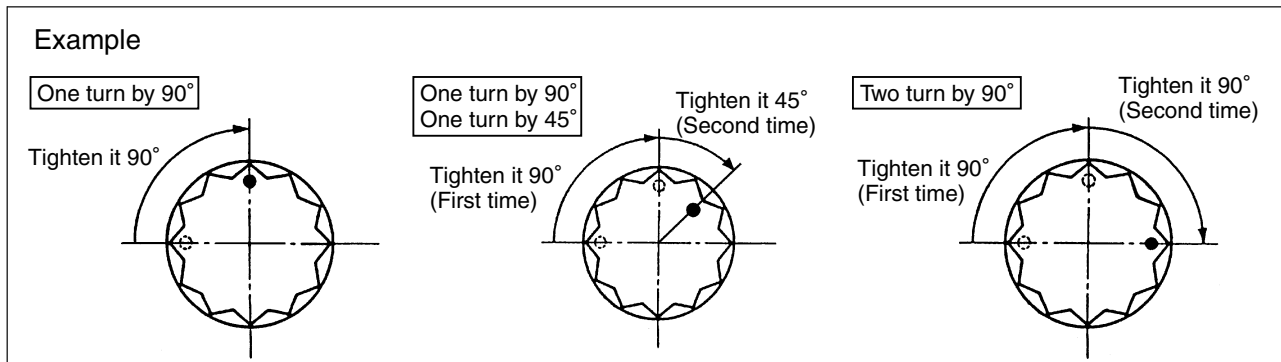

SAPH30ZCE0100008

- (1) Parts tightened
Cylinder head bolt, crankshaft main bearing cap bolt, connecting rod bearing cap bolt, etc.

- CAUTION**
- **Measure the overall length of the bolt before assembly and replace the bolt if the length exceeds the operation limit.**
 - **Apply engine oil to bolt seating and bolt thread in assembly.**

- (2) Tightening method after tightening to seating torque
Tightening of 90°, 135°(90°once and 45°once) and 180°(90°twice) is available.

Tightening of flare nuts and hoses

JP30ZCE010102004

1. Tightening torque of pipe flare nut

Unit : N·m{kgf·cm, lbf·ft}

Pipe outer diameter	$\phi 4.76$	$\phi 6.35$	$\phi 8$	$\phi 10$	$\phi 12$	$\phi 15$
Tightening torque	15±5 {153±50, 11±3.6}	21±1 {214±10, 15±0.7}	32±3 {326±31, 24±2.2}	44±5 {449±51, 32±3.6}	64±5 {653±51, 47±3.6}	66±2.5 {673±25, 47±1.8}

2. Tightening torque of hoses

Unit : N·m{kgf·cm, lbf·ft}

Type	Hose outer diameter $\phi 10.5$ fitting	Hose outer diameter $\phi 13, \phi 20, \phi 22$, fitting at packing	Hose outer diameter PF3/8 fitting
Air hose	21.5±1.5 {215±15, 15±1}	46±2.5 {469±25, 33±1.8}	—
	Only meter gauge 10 {100, 7}		
Brake hose	Packing 51.5±7.5 {525±75, 15±1}	46±2.5 {469±25, 33±1.8}	—

3. Lock nut tightening torque of brass joint

Unit : N·m{kgf·cm, lbf·ft}

Screw nominal size	M14	M16	M20	M22	M24
Tightening torque	48±10 {489±102, 35±7}	66±13 {673±204, 47±14}	120±36 {1224±367, 89±26}	130±30 {1326±306, 96±22}	150±30 {1530±306, 110±22}

Taper thread sealant for piping

JP30ZCE010102005

The taper thread of the air pipe joint has application of sealant [Loctite # 575 (by Japan Loctite)]. Follow the procedures below for connection or disconnection of pipes.

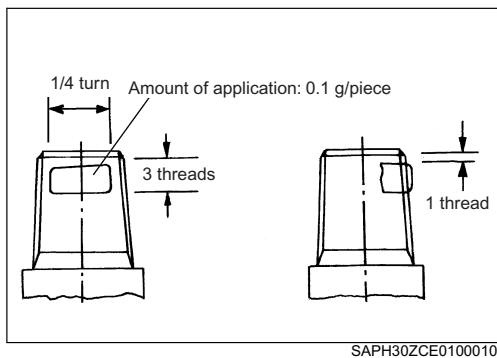
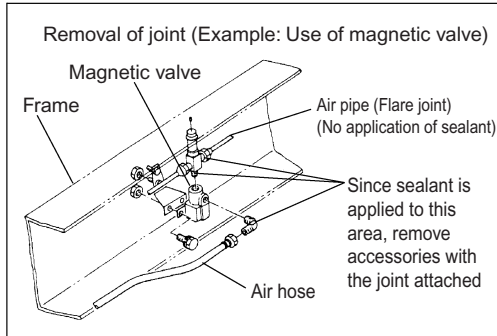

1. For disconnection

- (1) The sealant (# Loctite 575) has strong sealing feature. The return torque of the taper joint is increased about 1.5 times the initial tightening torque. When the joint is disconnected, use a long wrench for disconnection
- (2) When a joint at a poorly accessible area is replaced, remove accessories first and disconnect the joint.

2. For connection

- (1) For application of sealant (# Loctite 575), wipe the sealing area completely with a rag or thinner. Apply sealant directly to about three ridges for quarter round with offset of one ridge from the end. Tighten it according to the tightening torque in the table below. Remove dirt completely from the mating part (female) before tightening.

CAUTION • If your eye or skin comes in contact with sealant, wash it off immediately with water.

Tightening torque of taper joint

Unit : N·m{kgf·cm, lbf·ft}

Material	Screw diameter		
	1/4	3/8	1/2
Steel	49±10 {500±100, 36±7}	64±15 {650±150, 47±10}	
Aluminum or brass	25±5 {250±50, 18±3}	34±5 {350±50, 25±3}	44±5 {450±50, 32±3}

- (2) When a sealing tape is replaced with sealant, remove the tape completely first as in (1).

CAUTION • Be careful to prevent entry of dirt or foreign matter in the pipe.

- (3) If air leak is found after assembly with application of sealant, air leak cannot be stopped with additional tightening. Assemble the part again according to (1) and (2).

Assembly of joints and gaskets for piping

JP30ZCE010102006

1. Tightening torque of joints

Unit : N·m{kgf·cm, lbf·ft}

Screw size	Sealing method		
	Gasket sealing method (Aluminum + Rubber or Copper)	Metal sealing method (Flare pipe type, nipple connector type)	
		Type A	Type B
M8	13 {130, 9}		
M10	20 {200, 14}		11 {110, 8}
M12	25 {250, 18}	20 {200, 14}	
M14	25 {250, 18}	31 {320, 23}	
M16	29 {300, 22}	39 {400, 29}	
M18	39 {400, 29}	59 {600, 43}	
M20	*39 {400, 29}	64 {650, 47}	20 {200, 14}
M24	69 {700, 51}		
M28	*127 {1300, 94}		

2. Joint assembly procedure and subsequent inspection

- (1) Before assembly, make sure that there is no dirt or burr on the seating surface (mating part, pipe joint, gasket, etc.).
- (2) Since pipes have some degrees of freedom for assembly, the seating surface tends to incline. Tighten pipes finally after temporary tightening to prevent leak.
- (3) After tightening, apply the specified pressure to each pipe joint to ensure that there is no leak.
- (4) Observe the values above for each tightening torque.

*When assembled soft washer # 4840FR-N (aluminum and rubber carbon pressure bonding) is loosened or removed, be sure to replace it with a new part. This is not necessary for normal retightening.

3. Examples of joint methods in various pipes

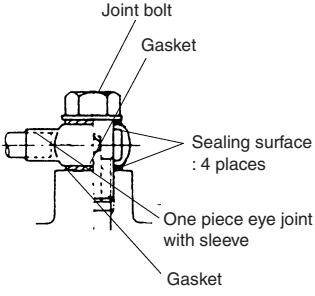
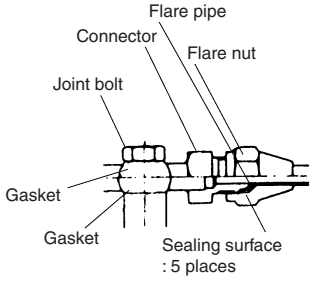
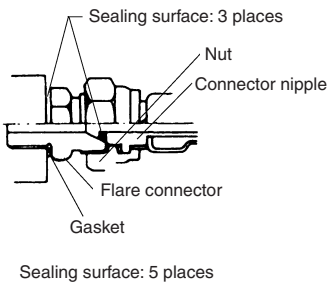
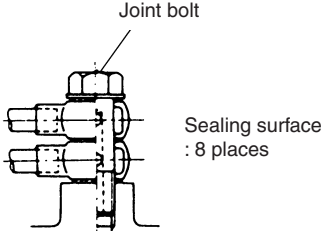
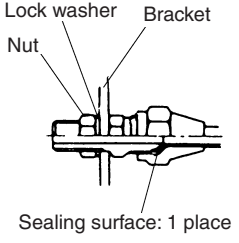
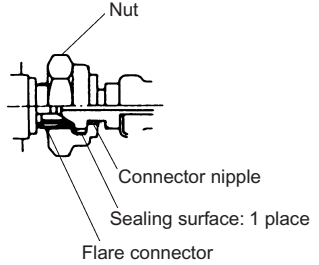
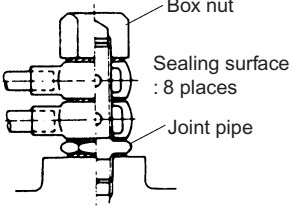
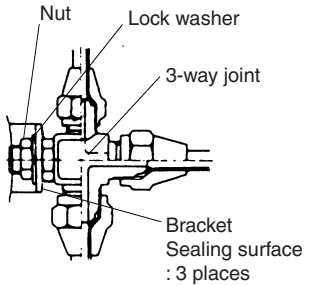
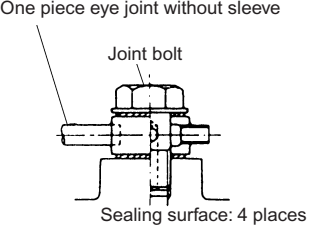
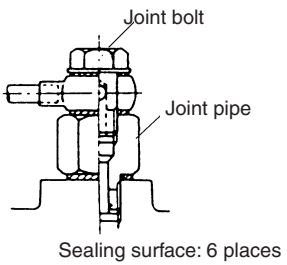
Gasket sealing method	Metal sealing method	
	Type A (Flare pipe type)	Type B (Nipple connector type)
 <p>Joint bolt Gasket Sealing surface : 4 places One piece eye joint with sleeve Gasket</p>	 <p>Flare pipe Connector Flare nut Joint bolt Gasket Gasket Sealing surface : 5 places</p>	 <p>Sealing surface: 3 places Nut Connector nipple Flare connector Gasket Sealing surface: 5 places</p>
 <p>Joint bolt Sealing surface : 8 places</p>	 <p>Lock washer Bracket Nut Sealing surface: 1 place</p>	 <p>Nut Connector nipple Sealing surface: 1 place Flare connector</p>
 <p>Box nut Sealing surface : 8 places Joint pipe</p>	 <p>Nut Lock washer 3-way joint Bracket Sealing surface : 3 places</p>	
 <p>One piece eye joint without sleeve Joint bolt Sealing surface: 4 places</p>		
 <p>Joint bolt Joint pipe Sealing surface: 6 places</p>		



Suggest:

For more complete manuals. Please go to the home page.

<https://www.ebooklibonline.com>

If the above button click is invalid. Please download this document first, and then click the above link to download the complete manual.

Thank you so much for reading

Handling of liquid gasket

JP30ZCE010102007

1. Application of liquid gasket and part assembly procedure

- (1) Remove old liquid gasket on each part and mating part completely. Clean the parts with a rag to prevent deposit of oil, moisture, dirt, etc.
Be sure to overlap parts at the beginning and at the end of application.
- (2) Be careful for offset with the mating part when a part applied with liquid gasket is assembled. Apply the liquid gasket again if offset occurs.
- (3) Assemble parts within 20 minutes after application of the liquid gasket.
If 20 minutes has passed, remove the liquid gasket and apply it again.
- (4) Start the engine at least 15 minutes or more after assembly of parts.

2. Removal of parts

- (1) When parts are removed, do not pry one place only. Remove parts by prying each other using collar or clearance on the flange. When gasket is removed, be careful to prevent entry of gasket offal into the engine.

3. Others

- (1) When the liquid gasket is contained in a tube, use the accompanying winding tool. When it is contained in a cartridge, use the application gun.

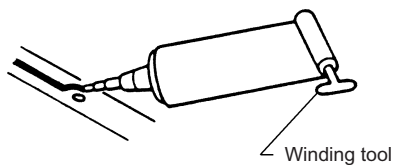

Tube: 150 g

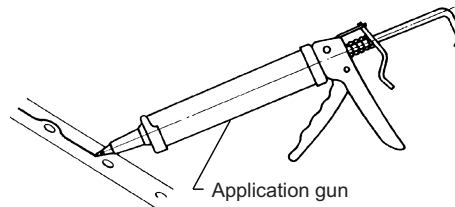

Cartridge type: 300 g

For a tube, desired application width may be obtained from the cut position at the nozzle end.

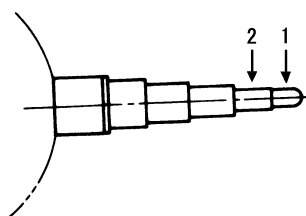

Nozzle of tube

- 1 : Approx. 2 mm at the 1st section cut
- 2 : Approx. 5 mm at the 2nd section cut

Failure diagnosis table for each problem

JP30ZCE010301001

Engine mechanical		Causes and actions are described for each item.	
Status	Cause	Action	
Engine overheat (coolant)	Insufficient coolant	Replenish coolant	
	Faulty thermostat	Replace thermostat	
	Water leak from cooling system	Correction	
	Faulty coolant pump	Repair or replace	
	Faulty head gasket	Replace head gasket	
Engine overheat (radiator)	Clogging of radiator	Cleaning of radiator	
	Corrosion of cooling system	Clean and repair cooling system	
	Clogging of radiator core front part	Clean radiator	
	Faulty radiator cap	Replace radiator cap	
Engine overheat (compression pressure)	Non-synchronous injection timing	Adjust injection timing.	
	Faulty fuel injection pressure	Adjust injection pressure	
	Faulty fuel	Replace with correct fuel	
	Faulty injector	Replace injector	
Engine overheat (lubrication unit)	Deterioration of engine oil	Replace engine oil	
	Faulty oil pump	Replace oil pump	
	Insufficient engine oil	Replenish engine oil	
Large engine oil consumption (piston, cylinder liner and piston ring)	Wear of piston ring and cylinder liner	Replace piston ring and cylinder liner	
	Damage to piston ring	Replace piston ring and cylinder liner	
	Faulty fixing of piston ring	Replace piston ring and cylinder liner	
	Faulty assembly of piston ring	Replace piston ring and cylinder liner	
	Faulty engine oil	Replace engine oil	
	Faulty piston ring joint	Reassemble piston ring	
Large engine oil consumption (valve and valve guide)	Wear of valve stem	Replace valve and valve guide	
	Wear of valve guide	Replace valve guide	
	Faulty assembly of valve stem seal	Replace stem seal	
	Excessive oil lubrication to rocker arm	Inspection of clearance between rocker arm and rocker arm shaft	
Large engine oil consumption (others)	Faulty oil level gauge	Replace with correct level gauge	
	Excessive filling of engine oil	Fill with appropriate amount of oil.	
	Leak of engine oil	Repair or replace the part of oil leak.	
Piston seizure (in operation)	Sudden stop of engine	Perform warm-up before stop of engine	
Piston seizure (lubrication unit)	Insufficient engine oil	Replenish engine oil	
	Deterioration of engine oil	Replace engine oil	
	Incorrect engine oil	Replace with correct engine oil.	
	Low oil pressure	Inspection of lubrication unit	
	Faulty oil pump	Replace oil pump	
Piston seizure	Abnormal combustion	Refer to overheat section.	
Piston seizure	Cooling unit	Refer to overheat section.	

JP03Z01020601001

SAPH30ZCE0100024

<https://www.ebooklibonline.com>

Hello dear friend!

Thank you very much for reading.

Enter the link into your browser.

The full manual is available for immediate download.

<https://www.ebooklibonline.com>