

PD 5700
Precision Air Hoe Drill

SERVICE MANUAL

Part number 87492432
1st edition English
April 2011



Contents

INTRODUCTION

HYDRAULIC, PNEUMATIC, ELECTRICAL, ELECTRONIC SYSTEMS A

PRIMARY HYDRAULIC POWER SYSTEM.....	A.10.A
LIGHTING SYSTEM.....	A.40.A
ELECTRONIC SYSTEM	A.50.A
FAULT CODES.....	A.50.A

AXLES, BRAKES AND STEERING..... D

FRONT AXLE	D.10.A
WHEELS AND TRACKS Wheels.....	D.50.C

FRAME AND CAB

FRAME Primary frame	E.10.B
---------------------------	--------

FRAME POSITIONING

TRAVELLING Folding	F.10.E
FRAME LEVELLING	F.30.A

FIELD PROCESSING

SEEDING Mechanical system.....	L.10.B
SEEDING Electronic system	L.10.C
SEEDING Air system.....	L.10.E
SOIL PREPARATION Planting	L.50.D



INTRODUCTION

<https://www.ebooklibonline.com>

Hello dear friend!

Thank you very much for reading.

Enter the link into your browser.

The full manual is available for immediate download.

<https://www.ebooklibonline.com>

Contents

INTRODUCTION

Advice	3
Foreword	4
FRAME - Safety signs	8
Basic instructions	16
Torque	18
Torque – Hydraulic Tubes and Fittings	20
Dimension	21
Weight	23
Product identification	24
Product identification	25

Advice

All repair and maintenance works listed in this manual must be carried out only by qualified dealership personnel, strictly complying with the instructions given; and using, whenever possible, the special tools.

Anyone who carries out the above operations without complying with the procedures shall be responsible for the subsequent damages.

The manufacturer and all the organizations of its distribution chain, including - without limitation - national, regional, or local dealers, reject any responsibility for damages due to the anomalous behavior of parts and/or components not approved by the manufacturer himself, including those used for the servicing or repair of the product manufactured or marketed by the manufacturer. In any case, no warranty is given or attributed on the product manufactured or marketed by the manufacturer in case of damages due to an anomalous behavior or parts and/or components not approved by the manufacturer.

The information in this manual is up-to-date at the date of the publication. It is the policy of the manufacturer for continuous improvement. Some information could not be updated due to modifications of a technical or commercial type, as well as to suit the law regulations of different countries.

In case of disagreement, refer to your Sales and Service Networks.

Foreword

Technical Information and ICE

This information in this manual has been structured using the Integrated Coding Environment (ICE). ICE is the way in which technical information is created, stored and retrieved in the Technical Information Database.

ICE coding classifies all information in three ways.

The first category is the Location, the second category is the Information Type and the third category is the Product:

- LOCATION - is the component, or function on the machine, that the piece of technical information is going to describe e.g. Fuel tank.
- INFORMATION TYPE - is the piece of technical information that has been written for a particular component or function on the machine. e.g., Capacity would be a type of Technical Data that would describe the amount of fuel held by the Fuel tank.
- PRODUCT - is the model that the piece of technical information is written for. e.g.,

Every piece of technical information will have those 3 categories attached to it. You will be able to use any combination of those categories to find the right piece of technical information you need to resolve that customers concern on his machine.

That information could be:

- the description of how to remove the cylinder head
- a table of specifications for a hydraulic pump
- a fault code
- a troubleshooting table
- a special tool

How to Use this Manual

This manual is divided into Sections. Each Section is then divided into Chapters. Contents pages are included at the beginning of the manual, then inside every Section and inside every Chapter. An alphabetical Index is included at the end of a Chapter. Page number references are included for every piece of technical information listed in the Chapter Contents or Chapter Index.

Each Chapter is divided into four Information types:

- Technical Data (specifications) for all the mechanical, electrical, or hydraulic devices, components, and assemblies.
- Functional Data (how it works) for all the mechanical, electrical, or hydraulic devices, components, and assemblies.
- Diagnostic Data (fault codes, electrical and hydraulic troubleshooting) for all the mechanical, electrical, or hydraulic devices, components, and assemblies.
- Service data (remove, disassemble, assemble, install) for all the mechanical, electrical, or hydraulic devices, components, and assemblies.

Sections

Sections are grouped according to the main functions or systems on the machine. Each Section is identified by a letter A, B, C etc. The number of Sections included in the manual will depend on the type and function of the machine that the manual is written for. Each Section has a Contents page listed in alphabetic/numeric order. This table illustrates which Sections could be included in a manual for a particular product.

INTRODUCTION

	SECTION											
	A - Hydraulic, Pneumatic, Electrical, Electronic Systems											
	B - Power Production											
	C - Power Train											
	D - Travelling											
	E - Body and Structure											
	F - Frame Positioning											
	G - Tool Positioning											
	H - Working Arm											
	J - Tools and Couplers											
	K - Crop Processing											
	L - Field Processing											
PRODUCT												
Tractors	X	X	X	X	X	X		X	X			
Vehicles with working arms: backhoes, excavators, skid steers,	X	X	X	X	X	X	X	X	X			
Combines, forage harvesters, balers, ...	X	X	X	X	X	X			X	X		
Seeding, planting, floating, spraying equipment, ...	X	X	X	X	X	X	X		X			X
Mounted equipment and tools,					X	X	X		X			

SECTION	LETTER	DESCRIPTION
HYDRAULIC, PNEUMATIC, ELECTRICAL ELECTRONIC SYSTEMS	A	This Section covers the main systems that interact with most of the functions of the product. It includes the central parts of the hydraulic, electrical, electronic, pneumatic, lighting and grease lubrication systems. The components that are dedicated to a specific function are listed in the Chapter where all the technical information for that function is included.
POWER PRODUCTION	B	This Section covers all the functions related to the production of power to move the machine and to drive various devices. In the case of a pulled-type machine, this Section covers the power take-off function where power is provided from the towing machine.
POWER TRAIN	C	This Section covers all the functions related to the transmission of power from the engine to the axles and to internal or external devices. This Section also covers the power take-off function where power is provided to the pull-type machine and additional Process Drive functions.
TRAVELLING	D	This Section covers all the functions related to moving the machine, including tracks, wheels, steering and braking. It covers all the axles; both driven axles and non-driven axles, including any axle suspension.
BODY AND STRUCTURE	E	This Section covers all the main functions and systems related to the structure and the body of the machine, including the frame, the shields, the operators cab and the platform. The functions related to the positioning of the machine frame are included in Section F, Frame Positioning.
FRAME POSITIONING	F	This Section covers all the main functions and systems related to positioning of the machine frame or to positioning the attachment on the supporting machine frame.
TOOL POSITIONING	G	This Section covers all the functions related to the final and/or automatic positioning of the tool once the tool is positioned using the Working Arm or the machine frame.
WORKING ARM	H	This Section covers all the functions related to the articulated or single arms mounted on the front or rear of the machine. A working arm can have various tools and quick couplers mounted on to it. The tools and quick couplers are included in Section J, Tools and Couplers.

INTRODUCTION

SECTION	LETTER	DESCRIPTION
TOOLS AND COUPLERS	J	This Section covers all the functions related to the specific tools that mount on the front, rear or beside the machine. The tools described here can be mounted with the positioning systems (lifting, side shift, swing) listed in Section G Tool Positioning. This Section covers all the quick coupling systems, located between the tool and the positioning system. The tools used for field preparation, soil preparation and treatment, planting and seeding are included.
CROP PROCESSING	K	This Section covers all the functions related to crop processing. Examples of crop processing include threshing, baling, windrowing, cutting and conditioning.
FIELD PROCESSING	L	This Section covers all the field processing functions of the machine. Examples of field process include seeding, fertilizer application, seedbed preparation and chemical application.

This manual contains these sections.

Contents

INTRODUCTION	
HYDRAULIC, PNEUMATIC, ELECTRICAL ELECTRONIC SYSTEMS	A
TRAVELLING	D
BODY AND STRUCTURE	E
FRAME POSITIONING	F
FIELD PROCESSING	L

Your manual contains these Sections. The contents of each Section are explained over the following pages.

Section Contents

SECTION A, HYDRAULIC, PNEUMATIC, ELECTRICAL ELECTRONIC SYSTEMS

SECTION D, TRAVELLING

SECTION E, BODY AND STRUCTURE

SECTION F, FRAME POSITIONING

SECTION L, FIELD PROCESSING

Chapters

Each Chapter is identified by a letter and number combination e.g. Seeding L.10.B. The first letter is identical to the Section letter i.e. Chapter L.10.B is inside Section L, Field Processing. The Chapter Contents lists all the "Technical Data" (specifications), "Functional Data" (how it works), "Service Data" (remove, install, adjust, etc.) and "Diagnostic Data" (fault codes and troubleshooting) that have been written in that Chapter for that function or system on the machine.

The Chapter Index lists in alphabetical order all the types of information (called Information Units) that have been written in that Chapter for that function or system on the machine.

Information Units and Information Search

Each chapter is composed of information units. The ICE coding is not included in the Information Unit title.

Page Header and Footer

The page header will contain the following references:

- Section and Chapter description

The page footer will contain the following references.

Printed references found at the base of each page then equate to

- The publication number for that Manual, Section, or Chapter
- Revision number of the publication
- Publication date
- Chapter reference (n/a)
- Page number

FRAME - Safety signs

KEEP SAFETY DECALS CLEAN.

Wipe clean when necessary.

REPLACE missing or unreadable decals. New decals are available from your dealer.

To replace decals:

1. Remove old decal and clean area.
2. Remove the decal backing and carefully affix the decal to the implement.
3. Using a clean piece of paper or the backing itself, work the air bubbles out from under the decal.

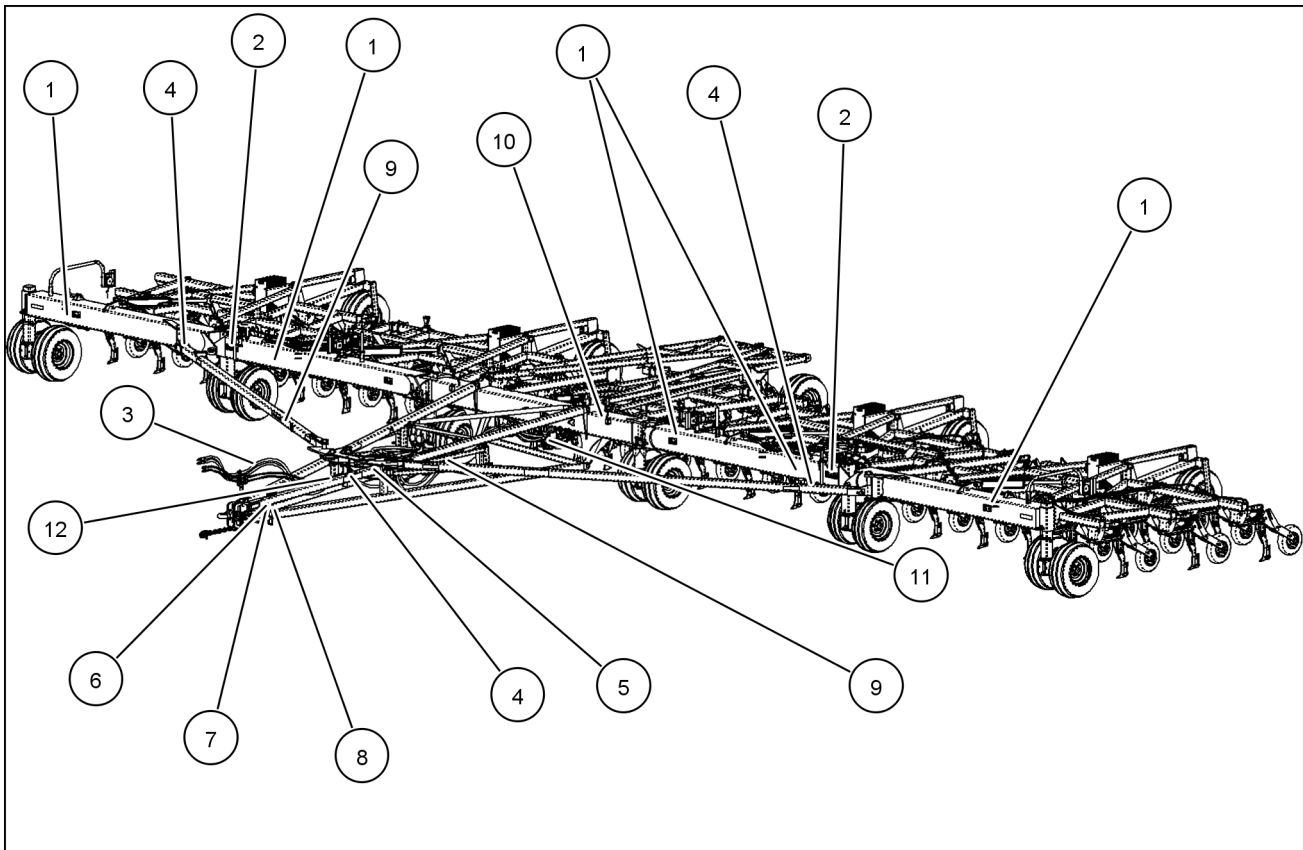

209154C 1

REF	Decal Description
(1)	DANGER- Keep clear of machine
(2)	WARNING - Drill may become unstable
(3)	Read your Operator's Manual
(4)	DANGER - Stay out of fold zone
(5)	DANGER - Rollover hazard
(6)	Do not ride.
(7)	CAUTION - Escaping fluid hazard
(8)	DANGER - Hitch upending hazard
(9)	IMPORTANT - Latches must be engaged
(10)	ATTENTION - To avoid unnecessary frame loading
(11)	CAUTION - Unauthorized removal of this decal will void warranty
(12)	WARNING - Hydraulic accumulator contains gas and oil under pressure.

DANGER

Keep clear of machine when folding or unfolding. Mechanical or hydraulic failure can allow wings to fall. Wing lock pins must be installed for transport, storage or when servicing.

Quantity: 4
English: 87503980

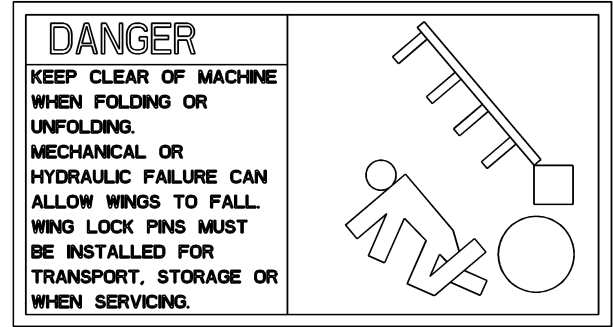

0687503980 2

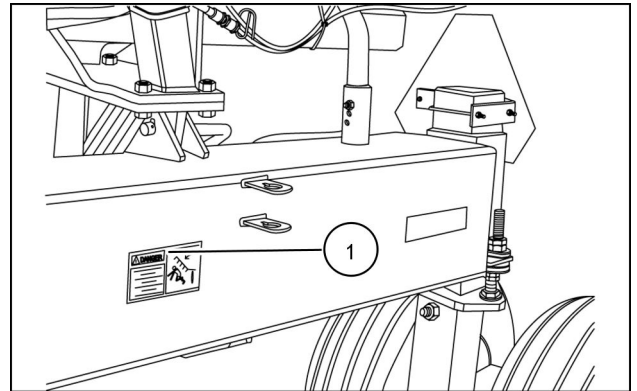

209241S 3

(1) two locations on each boom near wing lock pin storage locations.

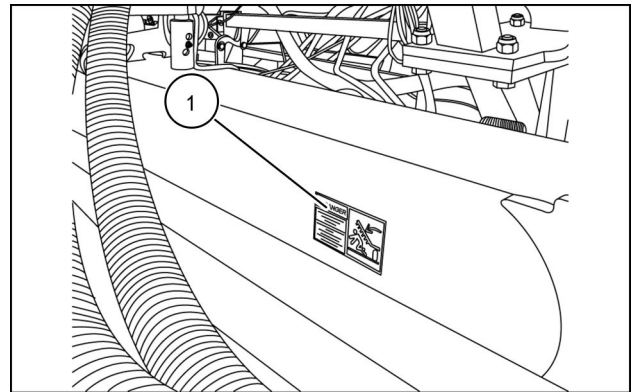

209242S 4

INTRODUCTION

WARNING

Drill may become unstable if caster locks are not engaged during transport.
Read manual, understand, maintain.

Quantity: 2
English: 87503996

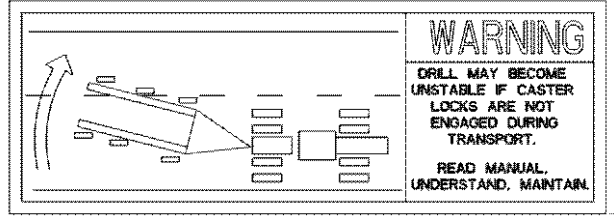

0687503996 5

(2) on left and right books near locking casters.

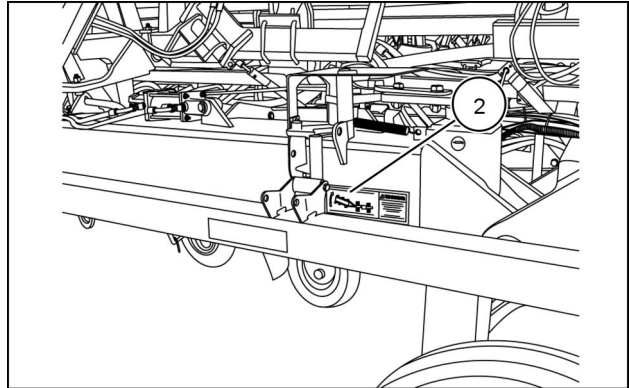

209240S 6

Read Your Operator's Manual
Quantity: 1.
English: 256147A1

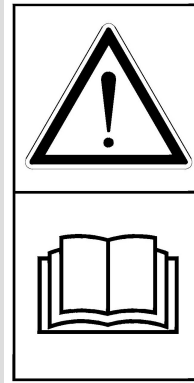

06256147A1 7

(3) on front hitch.

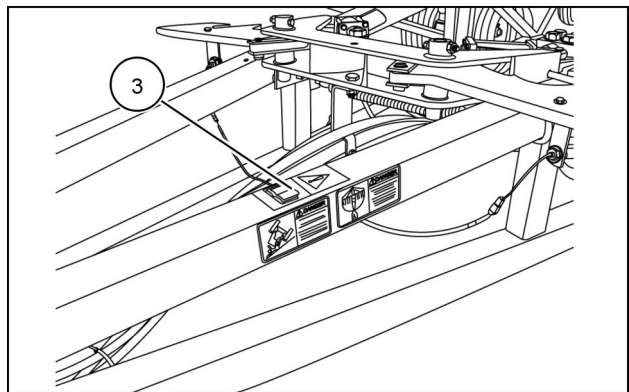

209236S 8

DANGER

**Stay out of fold zone.
Make sure everyone is clear of implements before
activating hydraulics.
Failure to follow instructions will result in serious
injury or death.**

**Quantity: 2
English: 87503802**

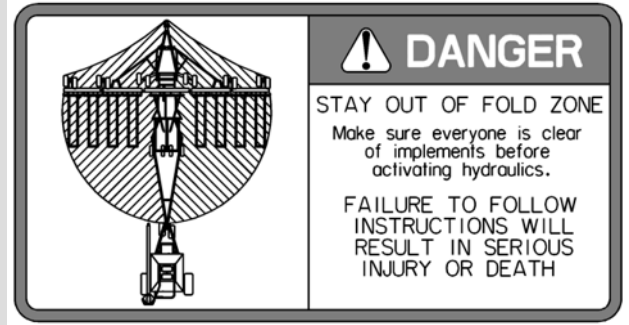

0687503802 9

(4) on hitch near boom latches.

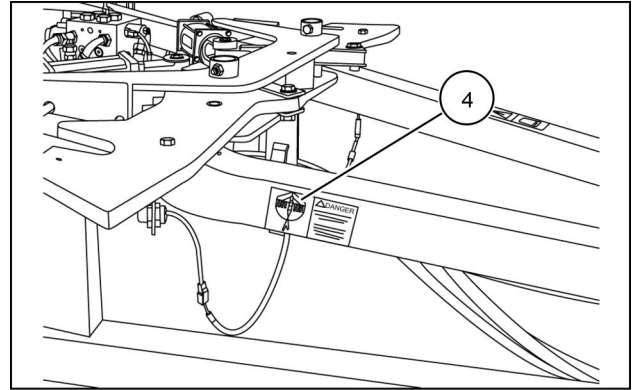

209243S 10

DANGER

**Rollover hazard.
Avoid excessive side slopes during transport.
Failure to follow instructions will result in serious
injury or death.**

**Quantity: 1
English: 87503829**

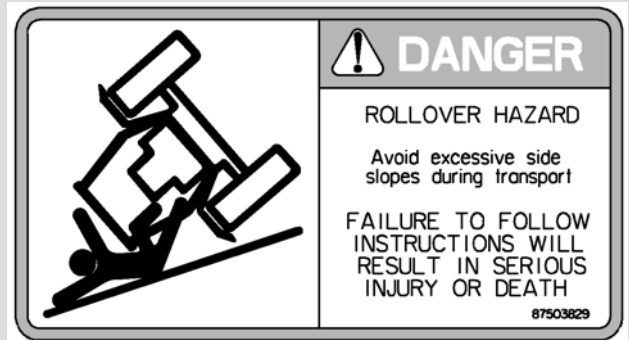

0687503829 11

(5) on front hitch.

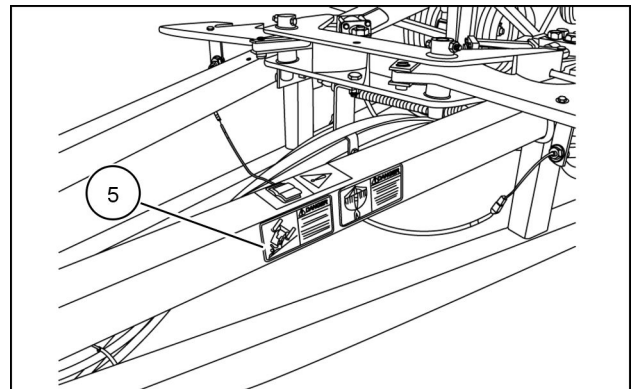

209235S 12

Warning - Do Not Ride
Quantity: 1
English: 182270A1



06182270A1 13

(6) on front hitch

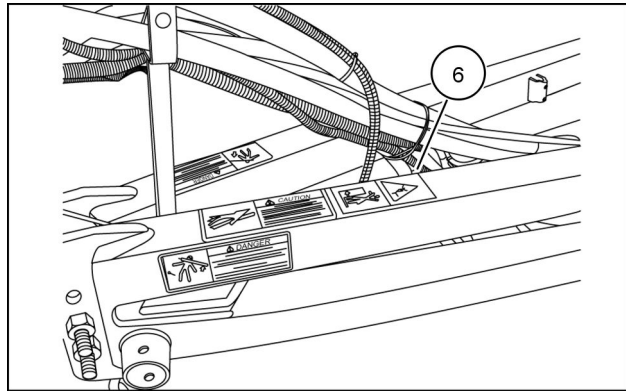

209236S 14

CAUTION

Escaping fluid hazard

Escaping hydraulic fluid under pressure can penetrate the skin causing serious injury. Relieve pressure before disconnecting hydraulic lines. Check / Tighten all connections **BEFORE** applying pressure. Use a piece of cardboard or paper to search for leaks. Do not use your hand.

IF ANY fluid is injected into the skin, it must be surgically removed within a few hours or **GANGRENE MAY RESULT**. Failure to follow these instructions could result in minor to moderate injury.

Quantity: 1
English: GD-500.77

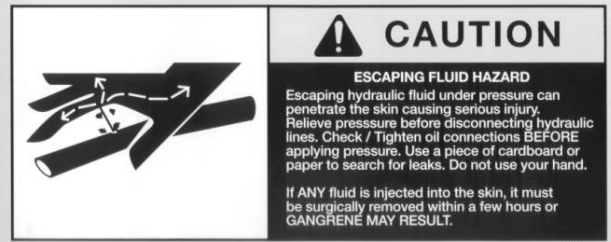

GD50077 15

(7) on hitch.

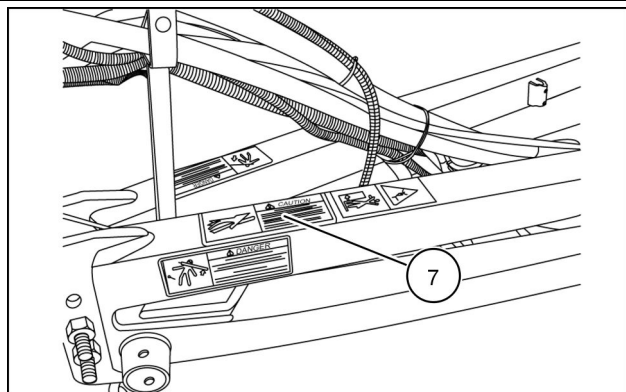

209236S 16

DANGER

Hitch upending hazard.
 To prevent hitch from rising abruptly, do not unpin implement if hitch is exerting upward pressure on the tractor drawbar.
 Refer to Operator's manual
 Failure to follow these instructions will result in serious injury or death.

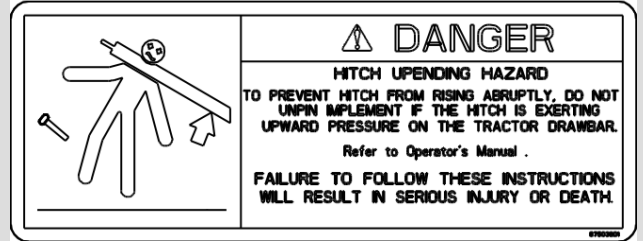

0687503801 17

Quantity: 2
English: 87503801

(8) on front hitch.

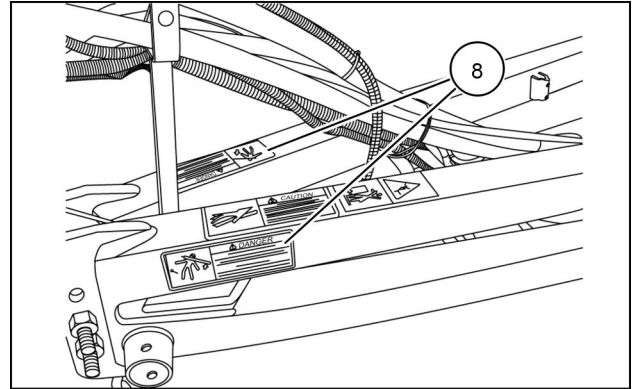

209236S 18

IMPORTANT

Latches must be engaged or damage to drill will occur.

Quantity:2
English: 87503994

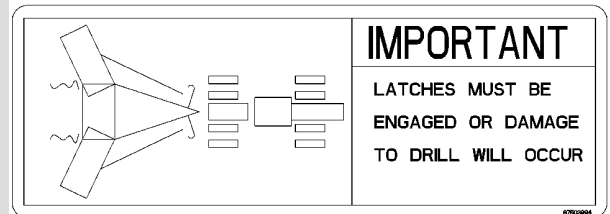

209178C 19

(9) on the left and right boom draw tubes.

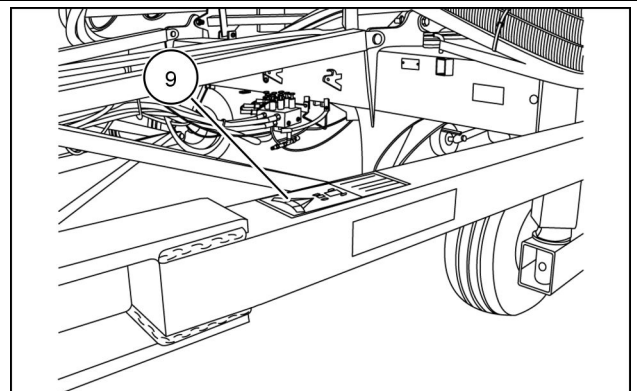

209239S 20

ATTENTION

To avoid unnecessary frame loading, casters must be in normal forward travel position (tires behind caster pivot) before raising or lowering wings. See Operator's manual

Quantity: 2
English: 87504060

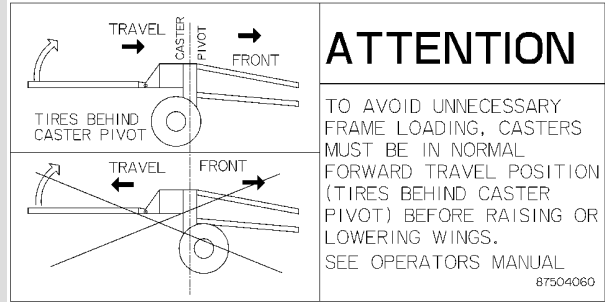

209181C 21

(10) on center boom on left and right sides, near caster.

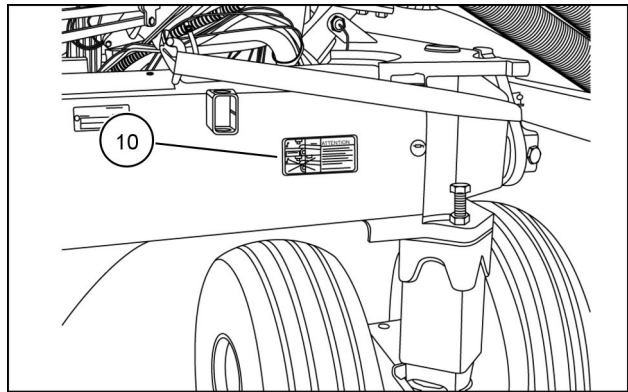

209238S 22

CAUTION

Unauthorized removal of this decal will void warranty. Contact service.
Overriding valves may cause machine to move suddenly and unexpectedly. Damage may occur. Failure to comply may result in death or serious injury.

Quantity: 2
English: 84260445

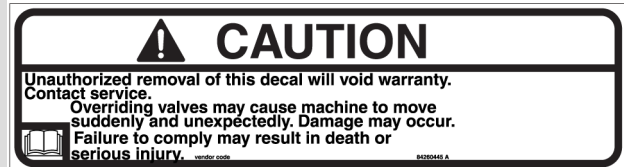

84260445 23

(11) on valve cover plate.

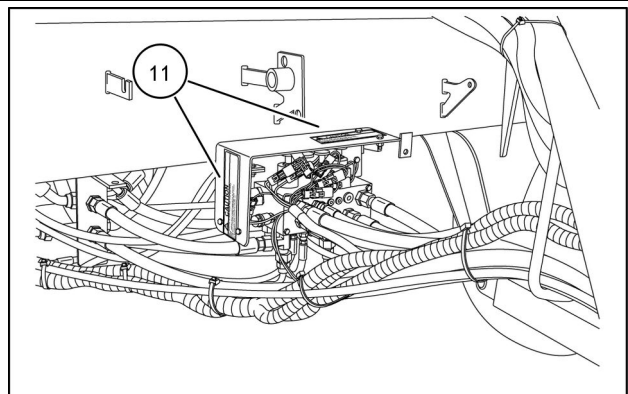

210627S 24

WARNING

Hydraulic accumulator contains gas and oil under pressure.

Service or repair must be performed only by trained service technician.

Failure to comply could result in death or serious injury.

Quantity: 1
English: 87054976



87054976N 25

(12) on accumulator mount plate.

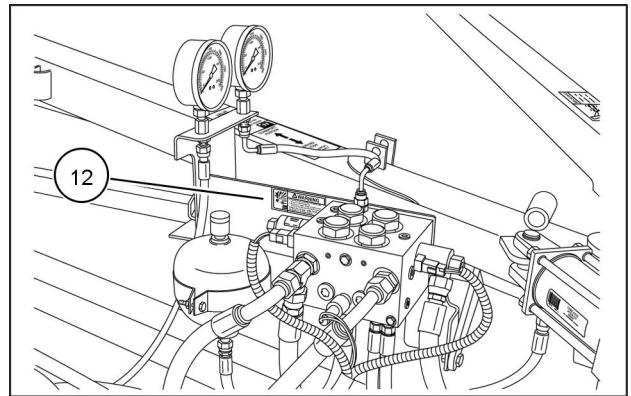

210626S 26

Basic instructions

HOW TO MEASURE VOLTAGES IN THE ELECTRONICS SYSTEM

When asked to measure a voltage, the voltage being measured is always at one point with respect to (relative to) the voltage at another point.

Example: To measure the voltage at point A with respect to point B, place one meter probe (typically red in color, and connected to the meter connector labeled "V"). Place the other meter probe (typically black in color, and connected to the meter connector labeled "COM").

If the units of voltage are specified as "volts dc", be sure your meter is set to "dc". If the units of voltage are specified as "volts ac", be sure your meter is set to "ac".

North American automotive electrical systems often use the chassis (metal frame) of the automobile as the return path (often referred to as ground) for electrical current. The electronics system does not use the chassis for a return path, and no voltage measurements should be made with respect to the chassis. All components in the electronics system should be considered to be electrically isolated from the chassis, although at the tractor the electronics system return is connected to the battery negative terminal which is in turn connected to the tractor chassis.

NOTE: On VR air carts with a battery and a hydraulic motor driven alternator, the air cart battery negative terminal is electrically isolated from the air cart chassis.

ELECTRICAL ISOLATION

Two points are electrically isolated when the resistance between them is "infinite" (very large, greater than **10,000,000 ohms**). To verify two points are electrically isolated.

1. Set your meter to measure resistance (usually labeled with the ohm symbol).
2. Hold the two probes apart from each other in the air. The meter must indicate infinite resistance (usually indicated by the infinity symbol or on digital multimeters, "++++" or "OL" for overload).
3. Hold the two probes together. The meter must indicate a very low resistance, less than **1.0 ohms**. The resistance measured will vary depending on what scale the meter is set to.
4. Place one probe on one point and the other probe on the other point. It does not matter which probe is placed on which point when measuring resistance. The meter must indicate infinite resistance as it did in 2 above for the two points to be electrically isolated.

ELECTRICAL CONTINUITY

Two points have electrical continuity when the resistance between them is very small, less than **0.1 ohms**. To verify two points have electrical continuity

1. Set your meter to measure resistance (usually labeled with the ohm symbol).
2. Since we are expecting to measure a resistance of **0 ohms**, set the scale to the lowest available.
3. Hold the two probes apart from each other in the air. The meter must indicate infinite resistance (usually indicated by the infinity symbol or on digital multimeters, "++++" or "OL" for overload).
4. Hold the two probes together. The meter must indicate a very low resistance, less than **1.0 ohms**. Record or memorize this resistance. This is the probe resistance.
5. Place one probe on one point and the other probe on the other point. It does not matter which probe is placed on which point when measuring resistance. Subtract the probe resistance measured in 4 above from the meter reading. If the meter reading minus the probe resistance is less than **0.1 ohms**, the two points have electrical continuity.

RESISTANCE

To measure the resistance between two points.

1. Set your meter to measure resistance (usually labeled with the ohm symbol).
2. Hold the two probes apart from each other in the air. The meter must indicate infinite resistance (usually indicated by the infinity symbol or on digital multimeters, "++++" or "OL" for overload).



Suggest:

For more complete manuals. Please go to the home page.

<https://www.ebooklibonline.com>

If the above button click is invalid. Please download this document first, and then click the above link to download the complete manual.

Thank you so much for reading



INTRODUCTION

3. Hold the two probes together. The meter must indicate a very low resistance, less than **1.0 ohms**. The resistance measured will vary depending on what scale the meter is set to
4. If the expected resistance is less than **20.0 ohms** ohms, go to 6.
5. Place one probe on one point and the other probe on the other point. It does not matter which probe is placed on which point when measuring resistance. Read the resistance indicated in the meter
6. Since we are expecting to measure a resistance less than **20.0 ohms**, set the meter to an appropriate scale, likely the lowest available.
7. Hold the two probes together. The meter must indicate a very low resistance, less than **1.0 ohms**. Record or memorize this resistance. This is the probe resistance.
8. Place one probe on one point and the other probe on the other point. It does not matter which probe is placed on which point when measuring resistance. Subtract the probe resistance measured in 7 above from the meter reading. The meter reading minus the probe resistance is the resistance between the two points.

Torque

BOLT TORQUE INFORMATION

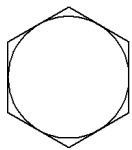
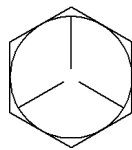
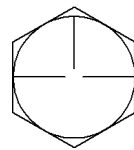
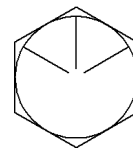
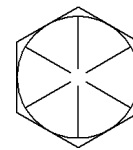
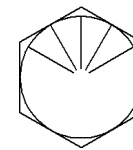
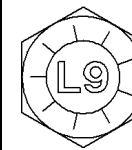
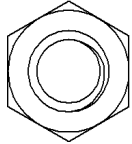
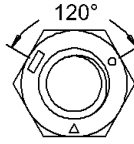
1. Fasteners should be replaced with the same or higher grade fasteners. If higher grade fasteners are used, these should only be tightened to the strength of the original.
2. Make sure the fastener's threads are clean and that thread engagement is started. This will prevent them from failing when being tightened.
3. Tighten plastic insert or crimped steel-type lock nuts to approximately **50 %** of the dry torque, applied to the nut, not to the bolt head. Tighten toothed or serrated-type lock nuts to the full torque value.
4. The L9 (Alloy) fasteners torque values are for a bolt, nut, and two washers. When using L9 (Alloy) fasteners, do not use the values in this table for tapped holes.

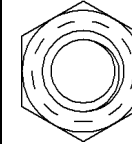
	GRADE						
	1 or 2	5	5.1	5.2	8	8.2	L9 (Alloy)
SAE Markings for Bolts and Cap Screws							
	2	5			8		L9 (Alloy)
SAE Markings for Hex Nuts							

SIZE	GRADE 2*		GRADE 5, 5.1 or 5.2		GRADE 8 or 8.2		GRADE L9 (Alloy)	
	Dry **	Lubricated **	Dry**	Lubricated **	Dry**	Lubricated **	Head	Nut
1/4 UNF	7.5 Nm	5.7 Nm	10.8 Nm	8.5 Nm	16.3 Nm	12.2 Nm	13.6 Nm	14.9 Nm
	5.5 lb ft	4.2 lb ft	8 lb ft	6.3 lb ft	12 lb ft	9 lb ft	10 lb ft	11 lb ft
1/4 UNC	8.5 Nm	6.4 Nm	13.6 Nm	9.8 Nm	19 Nm	13.6 Nm	16.3 Nm	17.6 Nm
	6.3 lb ft	4.7 lb ft	10 lb ft	7.2 lb ft	14 lb ft	10 lb ft	12 lb ft	13 lb ft
5/16 UNF	15 Nm	11 Nm	23 Nm	18 Nm	33 Nm	24 Nm	26 Nm	28 Nm
	11 lb ft	8 lb ft	17 lb ft	13 lb ft	24 lb ft	18 lb ft	19 lb ft	21 lb ft
5/16 UNC	16 Nm	12 Nm	26 Nm	19 Nm	37 Nm	27 Nm	27 Nm	31 Nm
	12 lb ft	9 lb ft	19 lb ft	14 lb ft	27 lb ft	20 lb ft	20 lb ft	23 lb ft
3/8 UNF	27 Nm	20 Nm	41 Nm	31 Nm	61 Nm	47 Nm	41 Nm	45 Nm
	20 lb ft	15 lb ft	30 lb ft	23 lb ft	45 lb ft	35 lb ft	30 lb ft	33 lb ft
3/8 UNC	31 Nm	23 Nm	47 Nm	34 Nm	68 Nm	47 Nm	47 Nm	52 Nm
	23 lb ft	17 lb ft	35 lb ft	25 lb ft	50 lb ft	35 lb ft	35 lb ft	38 lb ft
7/16 UNF	43 Nm	33 Nm	68 Nm	47 Nm	95 Nm	68 Nm	75 Nm	81 Nm
	32 lb ft	24 lb ft	50 lb ft	35 lb ft	70 lb ft	50 lb ft	55 lb ft	60 lb ft
7/16 UNC	49 Nm	37 Nm	75 Nm	54 Nm	108 Nm	81 Nm	81 Nm	88 Nm
	36 lb ft	27 lb ft	55 lb ft	40 lb ft	80 lb ft	60 lb ft	60 lb ft	65 lb ft
1/2 UNF	68 Nm	47 Nm	102 Nm	75 Nm	149 Nm	108 Nm	115 Nm	129 Nm
	50 lb ft	35 lb ft	75 lb ft	55 lb ft	110 lb ft	80 lb ft	85 lb ft	95 lb ft
1/2 UNC	75 Nm	54 Nm	115 Nm	88 Nm	163 Nm	122 Nm	129 Nm	142 Nm
	55 lb ft	40 lb ft	85 lb ft	65 lb ft	120 lb ft	90 lb ft	95 lb ft	105 lb ft
9/16 UNF	95 Nm	75 Nm	149 Nm	108 Nm	203 Nm	149 Nm	163 Nm	190 Nm
	70 lb ft	55 lb ft	110 lb ft	80 lb ft	150 lb ft	110 lb ft	120 lb ft	140 lb ft
9/16 UNC	108 Nm	81 Nm	163 Nm	122 Nm	231 Nm	176 Nm	183 Nm	203 Nm
	80 lb ft	60 lb ft	120 lb ft	90 lb ft	170 lb ft	130 lb ft	135 lb ft	150 lb ft
5/8 UNF	136 Nm	102 Nm	203 Nm	149 Nm	285 Nm	217 Nm	231 Nm	251 Nm
	100 lb ft	75 lb ft	150 lb ft	110 lb ft	210 lb ft	160 lb ft	170 lb ft	185 lb ft
5/8 UNC	149 Nm	115 Nm	231 Nm	176 Nm	325 Nm	244 Nm	258 Nm	278 Nm
	110 lb ft	85 lb ft	170 lb ft	130 lb ft	240 lb ft	180 lb ft	190 lb ft	205 lb ft

<https://www.ebooklibonline.com>

Hello dear friend!

Thank you very much for reading.

Enter the link into your browser.

The full manual is available for immediate download.

<https://www.ebooklibonline.com>