

# **DAVID BROWN**

**3-CYLINDER  
GASOLINE ENGINES**

## **REPAIR MANUAL**

PUBLICATION TP 665

**DAVID BROWN TRACTORS LIMITED  
MELTHAM · YORKSHIRE · ENGLAND · HD7 3AR**

March 1970



**Suggest:**

**For more complete manuals. Please go to the home page.**

**<https://www.ebooklibonline.com>**

**If the above button click is invalid. Please download this document first, and then click the above link to download the complete manual.**

**Thank you so much for reading**

# Introduction

This manual covers the maintenance and repair of gasoline engines fitted in David Brown 4600 and 3800 Selectamatic Tractors. As the 4600 Tractor is a gasoline engined version of the David Brown 880 Diesel Tractor and the 3800 Tractor a gasoline engined version of the David Brown 780 Diesel Tractor, Repair Manual TP 619 is also applicable to the clutch, transmission and hydraulic system, etc., of 4600 and 3800 Tractors.

## Engine Designation and Tractor Models

<i>Engine Series</i>	<i>Tractor Model</i>	<i>Tractor Number</i>
<b>349101</b>	<b>3800 Selectamatic Livedrive</b>	<b>650001 onward</b>
<b>355101</b>	<b>4600 Selectamatic Livedrive</b>	<b>900001 onward</b>

**<https://www.ebooklibonline.com>**

Hello dear friend!

Thank you very much for reading.

Enter the link into your browser.

The full manual is available for immediate download.

**<https://www.ebooklibonline.com>**

# CONTENTS

SECTION	Page
Maintenance .. .. .	2
Fuel System.. .. .	6
Ignition System .. .. .	13
Distributor .. .. .	14
Lubrication System .. .. .	16
Cooling System .. .. .	20
Repair Operations	
Engine Tune .. .. .	22
Decarbonising .. .. .	23
Pistons and Connecting Rods .. .. .	25
Crankshaft and Bearings .. .. .	26
Timing Gears.. .. .	27
Governor .. .. .	30
Engine Removal .. .. .	34
Dimensional Data .. .. .	36
Summary of Design Changes .. .. .	41
Approved Lubricants .. .. .	42

# MAINTENANCE

## Daily

Check engine oil level. Top up if necessary.

Check air cleaner. Remove filter bowl and examine the oil. In dusty conditions the air cleaner oil should be changed frequently, the detachable wire mesh element removed, washed in kerosene, and allowed to stand until all oil has drained off. (See note regarding air cleaner maintenance.)

If a paper element pre-cleaner is fitted, remove the cover and examine the element. If it is dirty, remove the element and tap it on the side to shake off dust. (Fig. 1.). **Do not attempt to wash a paper element.** Examine for any water, fuel or lubricating oil leaks.

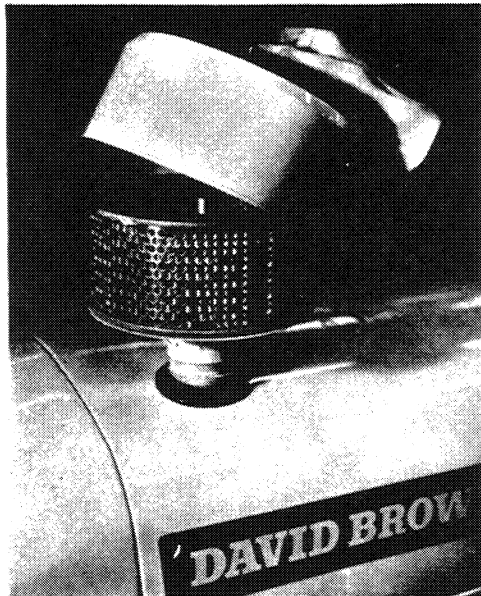

Figure 1. PAPER ELEMENT PRE-CLEANER

## Every 60 hours

Check engine oil level. Top up to the "full" mark on dipstick if required.

Check radiator water level and top up to within 1 in. (2.5 cm) from top if required. If the engine is hot, remove radiator cap slowly as the system is pressurised and may scald the hand if opened quickly.

Visually check the feed pump sediment bowl. Remove and clean if there is any accumulation of dirt or water.

## Air Cleaner

**Air Cleaner Oil:** Air cleaner oil should be changed and the detachable wire mesh element removed and in dusty conditions washed frequently.

The maximum dust deposit in the cleaner bowl should never be allowed to exceed  $\frac{1}{2}$  in., checked after standing overnight, otherwise oil pullover into the induction manifold will take place, due to the raised oil level. This pullover is highly detrimental and must be prevented by adequate cleaner maintenance.

An SAE 30 grade of straight mineral oil is less susceptible to frothing, and usually cheaper, than the detergent oils used in the engine. In climates where the ambient temperature often exceeds 32° C (90° F) an SAE 50 grade oil may be used. Care should be taken not to overfill the bowl. Only fill to the level mark — not above or below it.

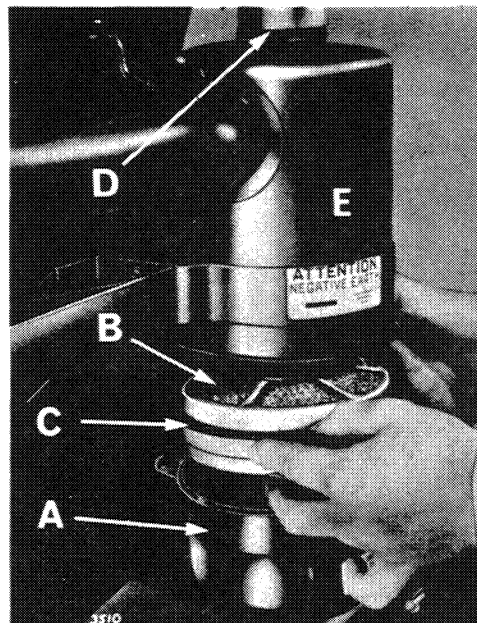

Figure 2. AIR CLEANER

- A. Oil bowl    B. Wire mesh    C. Rubber sealing rings  
D. Cleaner inlet pipe    E. Cleaner body

**Air Cleaner 'O' Rings:** When assembling the air cleaner care should be taken to ensure that the 'O' rings between the cleaner body, lower element and oil bowl are correctly fitted to ensure an air-tight seal. The fit of these 'O' rings is particularly important, as the upper ring may be easily displaced when the oil bowl and lower element are being fitted. The 'O' ring should not be twisted and should fit securely on the small notched register on the lower edge of the air cleaner body. If the 'O' rings are damaged during assembly new rings must be fitted. (Fig. 2.)

## Paper Element Pre-cleaner

This is an alternative fitting to the centrifugal type pre-cleaner and incorporates a replaceable paper

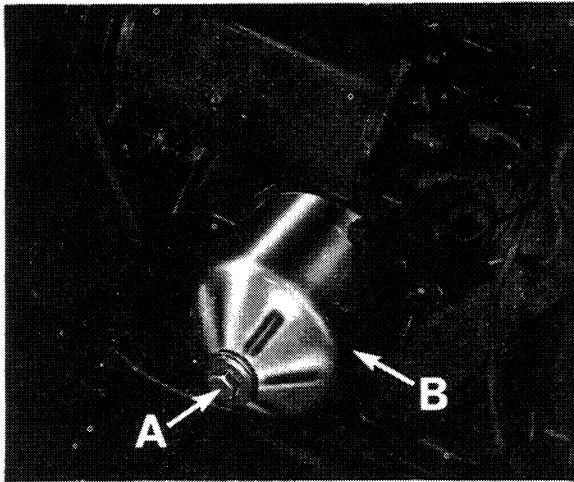

Figure 3. ENGINE OIL FILTER  
A. Securing bolt B. Filter bowl

element. Frequency of attention depends on working conditions and in dusty climates the cover should be removed every few hours of use and the element examined. The element can be cleaned by tapping its side to shake off the loose dust. If the element becomes very dirty, or contaminated with oil or water, it should be renewed. **Do not attempt to wash an element.**

### Every 125 hours

**Engine Oil:** Drain the oil, while it is still warm, through the sump plug on the underside of the sump plate. Refill with approved oil to within the safe marks on the dipstick. For list of approved lubricants see Page 42.

### Every 250 hours

**Engine Oil and Filter:** Drain the oil when warm and remove filter bowl. Discard the old element and

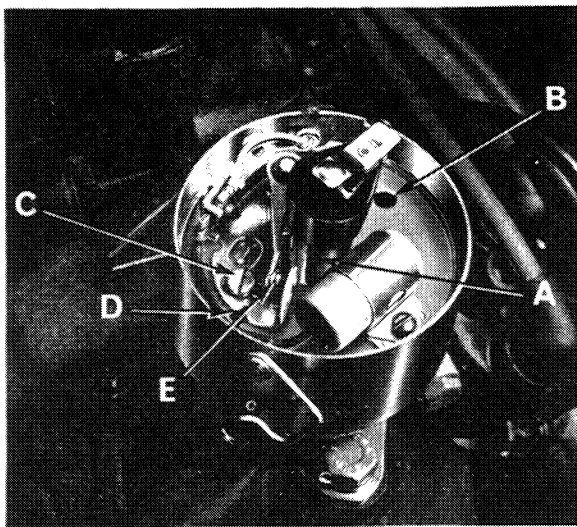

Figure 4. DISTRIBUTOR  
A. Cam B. Oil hole C. Fixed point screw  
D. Screwdriver slot E. Contact points

clean bowl out with clean kerosene, using a brush to make sure that the by-pass valve is perfectly clean. Fit a new element and check the sealing ring in the cylinder block groove; fit a new ring if it is damaged or distorted. Do not overtighten the bowl securing bolt — 10 lb ft is sufficient. (Fig. 3.)

Refill the sump with new oil, start engine to fill the filter then recheck the oil level.

**Distributor:** Remove the contact-breaker points and clean the contact faces. Renew the points if badly pitted. After refitting the points turn the engine until the points are fully open then set the gap to 0.020 in.

Apply a small quantity of high-melting-point grease to the cam and a few drops of oil into the centre of the shaft and through the oil-holes in the baseplate. (Fig. 4.)

Replace the rotor and distributor cap. Wipe all oil and dirt from the ignition coil, distributor cap and high-tension wiring.

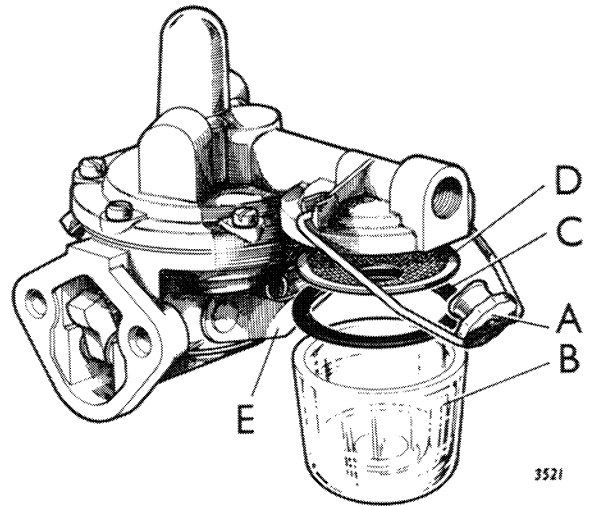

Figure 5. FUEL FEED PUMP SEDIMENT BOWL  
A. Bowl securing nut B. Sediment bowl  
C. Sealing ring D. Filter screen  
E. Pump priming lever

**Spark Plugs:** Remove, clean and re-set the gaps to 0.025 in. by adjusting the side electrode. Do not attempt to bend the centre electrode.

### Every 500 hours

**Sediment Bowl:** Remove the sediment bowl and filter screen, wash in gasoline and replace. (Fig. 5.)

**Spark Plugs:** Remove the spark plugs and fit a new set of plugs of the correct type (see Page 39). Set the plug gaps to 0.025 in. before fitting.

**Valve Clearance:** Remove valve rocker cover and check valve clearances when engine is cold. The valve clearance should be set cold to inlet 0.010 in. and exhaust 0.007 in. The clearance between the tip of rocker arm and the end of valve stem should be checked with a feeler gauge as

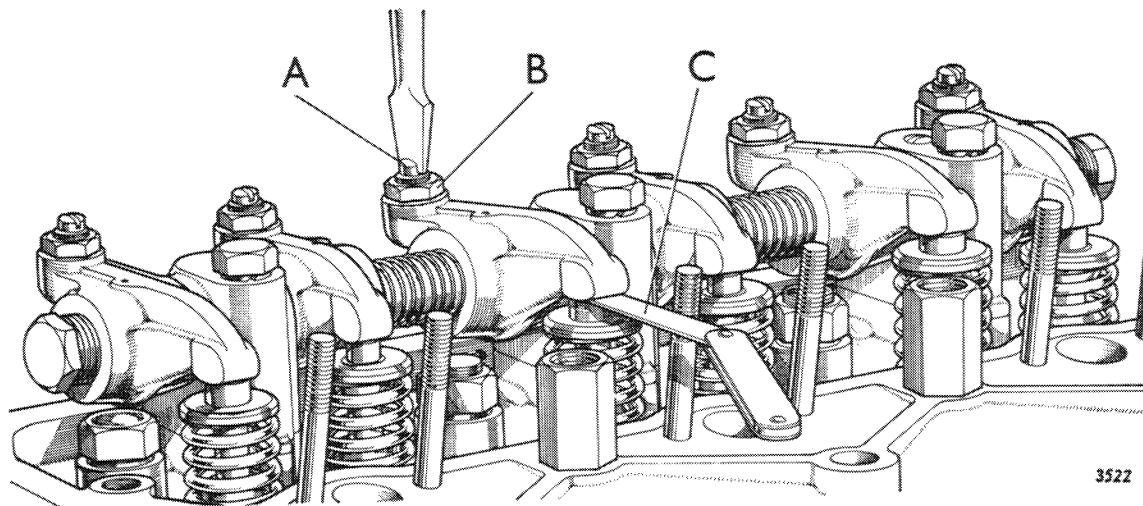

3522

Figure 6. SETTING THE VALVE CLEARANCES

A. Adjusting screw B. Locknut C. Feeler gauge

shown on Fig. 6 and adjusted, if necessary, to the correct clearance. Adjustment is made by slackening the locknut and turning the adjusting screw until correct clearance is obtained. When tightening the locknut hold adjusting screw firmly with a screwdriver, then re-check the clearance. As it is important that the tappet is on the base of the cam when valve clearance is set, the valves should be adjusted in the manner described below. (Fig. 6.)

Relative position of valves is as follows:

No. 1 Cylinder (Front)		No. 2 Cylinder (Centre)		No. 3 Cylinder (Rear)	
Exhaust	Inlet	Exhaust	Inlet	Exhaust	Inlet

Using a  $\frac{1}{8}$  AF socket and suitable bar, turn engine slowly forward and observe which exhaust valve is

closing and continue turning until the inlet valve of the same cylinder starts to open. When these two valves are open by the same amount stop turning. It is possible to turn the engine backwards and forwards to attain the correct point. This position is known as having the valves "rocking". Set the clearance of the corresponding valves and repeat the procedure on the other two cylinders.

Order of Valve Setting:

Valves Rocking

No. 1 cylinder  
No. 2 cylinder  
No. 3 cylinder

Set Valves

No. 2 inlet and No. 3 exhaust  
No. 3 inlet and No. 1 exhaust  
No. 1 inlet and No. 2 exhaust

**Fan Belt:** Check tension by deflecting belt midway between the dynamo and crankshaft pulleys. It should deflect approximately 1 in. and if necessary may be adjusted by releasing the three dynamo mounting bolts and swinging dynamo on the two lower bolts. Tighten upper bolt first, as this will hold dynamo in position whilst the lower bolts are tightened. Do not overtighten the belt. A taut belt will place excessive load on the dynamo and water pump bearings and cause rapid belt wear. If the belt has insufficient tension when dynamo has been

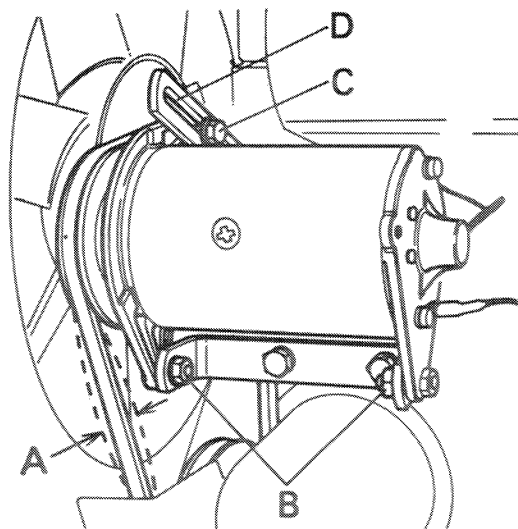
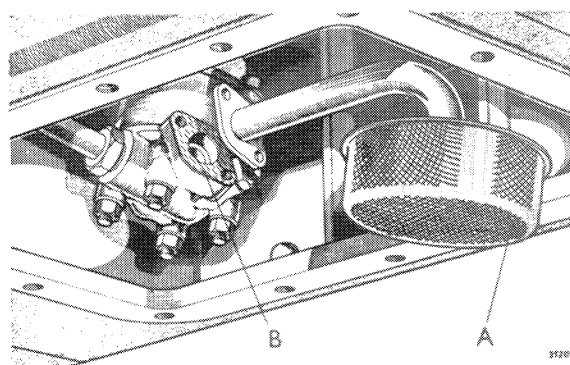

Figure 7. FAN BELT ADJUSTMENT

A. Belt deflection (1 in.) B. Lower mounting bolts  
C. Upper mounting bolt D. Adjustment slot



3520

Figure 8. ENGINE OIL PUMP SCREEN

A. Filter screen B. Gasket

**<https://www.ebooklibonline.com>**

Hello dear friend!

Thank you very much for reading.

Enter the link into your browser.

The full manual is available for immediate download.

**<https://www.ebooklibonline.com>**