

# SC101 Pivot Tongue Frame

## Service Manual

84207376 2/09  
1st Printing



# **SC101 SERVICE MANUAL CONTENTS**

**SECTION 00 - GENERAL INFORMATION**

**SECTION 35 - HYDRAULIC SYSTEM**

**SECTION 39 - FRAME AND TONGUE**

**SECTION 44 - AXLES AND WHEELS**

**SECTION 55 - ELECTRICAL SYSTEM**

**SECTION 90 - SAFETY DECALS**

**The sections used through out all Case IH product Service manuals may not be used for each product. Each Service manual will be made up of one or several books. Each book will be labeled as to which sections are in the overall Service manual and which sections are in each book.**

**The sections listed above are the sections utilized for the SC101.**

## SECTION 00 - GENERAL INFORMATION

### Chapter 1 - General Information

#### CONTENTS

Section	Description	Page
	Precautionary Statements .....	2
	Safety .....	3
	Ecology and the Environment .....	4
	Universal Symbols .....	5
	Lubrication .....	6
	General Information .....	6
	Grease Fittings .....	6
	Chains .....	6
	Recommended Lubricants and Coolants .....	7
	Lubrication and Service Points .....	8
	Minimum Hardware Tightening Torques .....	11
	Installation of Adjustable Fittings in Straight Thread O Ring Bosses .....	13
	Standard Torque Data for Hydraulic Tubes and Fittings .....	13
	Pipe Thread Fitting Torque .....	14
	Installation of ORFs (O Ring Flat Faced) Fittings .....	14
	Introduction .....	15
	Product Identification Number Locations .....	15
	Frame Product Identification Number .....	15
	Tongue Product Identification Number .....	15
	Toolbox .....	16
	Manual Holder .....	16
	Safety Chain .....	17
	Jack Assembly .....	18
	Tractor Requirements .....	19
	Tractor Drawbar Dimensions .....	19
	Attaching to the Tractor .....	20
	Drawbar Extension .....	21
	Transporting the Mower-Conditioner .....	22
	Safety Chain .....	22
	SMV Emblem .....	22
	Trailing Lights .....	22
	Towing with a Tractor .....	23
	Towing with a Truck .....	24
	Parking the Machine .....	25
	Specifications .....	26

**<https://www.ebooklibonline.com>**

Hello dear friend!

Thank you very much for reading.

Enter the link into your browser.

The full manual is available for immediate download.

**<https://www.ebooklibonline.com>**

# PRECAUTIONARY STATEMENTS

## PERSONAL SAFETY

Throughout this manual and on machine decals, you will find precautionary statements (“**DANGER**”, “**WARNING**”, and “**CAUTION**”) followed by specific instructions. These precautions are intended for the personal safety of you and those working with you. Please take the time to read them.

---

 **DANGER** 

---

This word “**DANGER**” indicates an immediate hazardous situation that, if not avoided, will result in death or serious injury. The color associated with Danger is RED.

M1169

---

---

 **WARNING** 

---

This word “**WARNING**” indicates a potentially hazardous situation that, if not avoided, could result in death or serious injury. The color associated with Warning is ORANGE.

M1170

---

---

 **CAUTION** 

---

This word “**CAUTION**” indicates a potentially hazardous situation that, if not avoided, may result in minor or moderate injury. It may also be used to alert against unsafe practices. The color associated with Caution is YELLOW.

M1171

---

**FAILURE TO FOLLOW THE “DANGER”, “WARNING”, AND “CAUTION” INSTRUCTIONS MAY RESULT IN DEATH OR SERIOUS BODILY INJURY.**

## MACHINE SAFETY

The precautionary statement (“**IMPORTANT**”) is followed by specific instructions. This statement is intended for machine safety.

**IMPORTANT:** *The word “IMPORTANT” is used to inform the reader of something he needs to know to prevent minor machine damage if a certain procedure is not followed.*

## INFORMATION

**NOTE:** *Instructions used to identify and present supplementary information.*

# SAFETY

## PRECAUTIONARY STATEMENTS

A careful operator is the best operator. Most accidents can be avoided by observing certain precautions. To help prevent accidents, read the following precautions before operating this equipment. Equipment should be operated only by those who are responsible and instructed to do so.

Carefully review the procedures given in this manual with all operators. It is important that all operators be familiar with and follow safety precautions.

1. **Always disengage the PTO, lock the tractor brakes, and shut off the tractor engine before:**
  - Leaving the tractor seat.
  - Lubricating.
  - Cleaning or unplugging any part of the machine.
  - Adjusting the machine.
2. **Always lower the header to the ground or engage the transport stops when parking.**
3. **Always use the header transport stops and spring-loaded tongue safety lock when transporting the machine.**
4. **Never work under a raised header unless it is securely locked with the header transport stops.**
5. **Always block the wheels before working on or under the machine.**
6. **Do not start the machine until you know that everyone is clear of the machine and have made sure no tools are lying on it.**
7. **Keep all shields in place. Never work around the machine in loose clothing that could catch in a moving part.**
8. **Do not modify any shields or operate the machine with any shields removed.**
9. **Always use adequate lights and safety warning devices when transporting the machine on public roads or after dark. Check with your local law enforcement agencies for specific requirements.**
10. **Limit towing speeds to 32 km/hr (20 mph) maximum.**
11. **Never stand behind the trail frame while it is running.**
12. **Operate the machine only at the PTO speed for which it is designed. Attach a 540 rpm implement only to a 540 rpm PTO and a 1000 rpm implement to a 1000 rpm PTO.**
13. **Long exposure to loud noise can damage your hearing. Wear a suitable hearing protection device such as earmuffs or ear plugs if you are exposed to uncomfortable noise levels.**
14. **Be sure no one is standing near or touching the machine before raising or lowering the header.**
15. **Use the safety chain when transporting the unit on a public road.**
16. **DO NOT weld on wheels. Welding on wheels may cause high stress and a wheel failure.**
17. **DO NOT weld on wheels with a mounted tire. Welding on wheels with a mounted tire may cause the tire to burst, causing serious injury or death.**

## ECOLOGY AND THE ENVIRONMENT

Soil, air, and water are vital factors of agriculture and life in general. When legislation does not yet rule on the treatment of some of the substances which are required by advanced technology, common sense should govern the use and disposal of products of a chemical and petrochemical nature.

The following are recommendations which may be of assistance:

























- Become acquainted with and ensure that you understand the relative legislation applicable to your country.
- Where no legislation exists, obtain information from suppliers of oils, filters, batteries, fuels, antifreeze, cleaning agents, etc., with regard to their effect on man and nature and how to safely store, use and dispose of these substances. Agricultural consultants will, in many cases, be able to help you as well.

### HELPFUL HINTS

1. Avoid filling tanks using cans or inappropriate pressurized fuel delivery systems which may cause considerable spillage.
2. In general, avoid skin contact with all fuels, oils, acids, solvents, etc. Most of them contain substances which may be harmful to your health.
3. Modern oils contain additives. Do not burn contaminated fuels and or waste oils in ordinary heating systems.
4. Avoid spillage when draining off used engine coolant mixtures, engine, gearbox and hydraulic oils, brake fluids, etc. Do not mix drained brake fluids or fuels with lubricants. Store them safely until they can be disposed of in a proper way to comply with local legislation and available resources.
5. Modern coolant mixtures, i.e. antifreeze and other additives, should be replaced every two years. They should not be allowed to get into the soil but should be collected and disposed of safely.
6. Do not open the air-conditioning system yourself. It contains gases which should not be released into the atmosphere. Your dealer or air conditioning specialist has a special extractor for this purpose and will have to recharge the system properly.
7. Repair any leaks or defects in the engine cooling or hydraulic system immediately.
8. Do not increase the pressure in a pressurized circuit as this may lead to a component failure.
9. Protect hoses during welding as penetrating weld splatter may burn a hole or weaken them, allowing the loss of oils, coolant, etc.

## UNIVERSAL SYMBOLS

As a guide to the operation of your tractor, various universal symbols have been utilized on the instruments, controls, switches, and fuse box. The symbols are shown below with an indication of their meaning.

	Thermostart starting aid		Radio		P.T.O.		Position Control
	Alternator charge	<b>KAM</b>	Keep alive memory	<b>N</b>	Transmission in neutral		Draft Control
	Fuel level		Turn signals		Creeper gears		Accessory socket
	Automatic Fuel shut-off		Turn signals -one trailer		Slow or low setting		Implement socket
	Engine speed (rev/min x 100)		Turn signals -two trailers		Fast or high setting		%age slip
	Hours recorded		Front wind-screen wash/wipe		Ground speed		Hitch raise (rear)
	Engine oil pressure		Rear wind-screen wash/wipe		Differential lock		Hitch lower (rear)
	Engine coolant temperature		Heater temperature control		Rear axle oil temperature		Hitch height limit (rear)
	Coolant level		Heater fan		Transmission oil pressure		Hitch height limit (front)
	Tractor lights		Air conditioner		FWD engaged		Hitch disabled
	Headlamp main beam		Air filter blocked		FWD disengaged		Hydraulic and transmission filters
	Headlamp dipped beam		Parking brake		Warning!		Remote valve extend
	Work lamps		Brake fluid level		Hazard warning lights		Remote valve retract
	Stop lamps		Trailer brake		Variable control		Remote valve float
	Horn		Roof beacon		Pressurized! Open carefully		Malfunction! See Operator's Manual
			Warning! Corrosive substance				Malfunction! (alternative symbol) See Operator's Manual

## LUBRICATION

Adequate lubrication and maintenance on a regular schedule is vital to maintaining your equipment. To ensure long service and efficient operation, follow the lubrication and maintenance schedules outlined in this manual. The use of proper fuels, oils, grease and filters, as well as keeping the systems clean, will also extend machine and component life.

**IMPORTANT:** Always use genuine **New Holland** replacement parts, oils and filters to ensure proper operation, filtration of engine and hydraulic systems. See your **New Holland** dealer for additional oil quantities.

### GENERAL INFORMATION

Regular lubrication is the best insurance against delays and repairs. Proper lubrication will extend machine life. Refer to the following charts for lubricants and service intervals.

**IMPORTANT:** Failure to complete the required maintenance at the recommended intervals can cause unnecessary downtime.

The intervals listed in the Lubrication Chart are guidelines to be used when operating in normal conditions. Adjust the intervals for operating in adverse environmental and working conditions. The intervals should be shortened for sandy, dusty and extremely hot operating conditions.

---

### WARNING

---

**All Service, Lubrication and Adjustment procedures in this manual should be performed with the machine on a FIRM level surface, with all attachments down on the surface, engine off and key removed, unless otherwise specified. Failure to comply could result in death or serious injury.**

M1404

---

---

### WARNING

---

**Some illustrations in this manual show shields opened or removed to display areas being serviced. Replace all shields before operating the machine. Failure to comply could result in death or serious injury.**

M1213

---

Always clean the area around dipsticks, fill caps, and check plugs when checking fluid levels. Failure to clean these areas may allow contamination to enter the system. Drain, flush and refill the system anytime you suspect it is contaminated.

### Grease Fittings

Wipe dirt from fittings before greasing.

Pump fresh grease into fitting to adequately lubricate the component and force out any contamination from the grease passage.

Wipe off excess grease.

Use a grease gun containing clean high grade of multipurpose grease.

### Chains

Stop all drives before lubricating chains.

SECTION 00 - GENERAL INFORMATION - CHAPTER 1

**RECOMMENDED LUBRICANTS AND COOLANTS**

<b>Lubricant</b>	<b>Type and Description</b>	<b>Container Size</b>
<b>Engine Oil</b>	Case Akcela No. 1 Engine Oil 10W30	1QT / .946L
		1G / 3.785L
		2.5G / 9.46L
		5G / 18.93L
<b>Hydraulic Oil</b>	Case Nexplore	1QT / .946L
		1G / 3.785L
		2.5G / 9.46L
		5G / 18.93L
<b>Gear Oil</b>	Case Akcela 135 H EP 80W90	1QT / .946L
		2.5G / 9.46L
		16G / 60.6L
<b>Grease</b>	Case Akcela 251 H EP	TUBE - 14 OZ.



**Suggest:**

**For more complete manuals. Please go to the home page.**

**<https://www.ebooklibonline.com>**

**If the above button click is invalid. Please download this document first, and then click the above link to download the complete manual.**

**Thank you so much for reading**

## LUBRICATION AND SERVICE POINTS

Lubrication points and service points are shown on the following pages along with the interval of service to be done. Grease points are indicated by a grease gun symbol with the hour interval following. Under adverse conditions, shorten the lubrication intervals.



Some illustrations in this manual show shields opened or removed to display areas being serviced. Replace all shields before operating the machine. Failure to comply could result in death or serious injury.

M1213

### EVERY 10 HOURS OF OPERATION OR DAILY

Grease the header lift arms, 1.  
(1 fitting right-hand side, 1 fitting left-hand side)

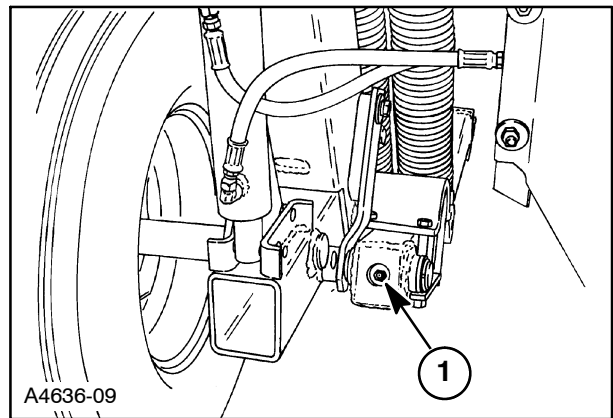

1

Grease the wheel arms, 1.  
(1 fitting right-hand side, 1 fitting left-hand side)

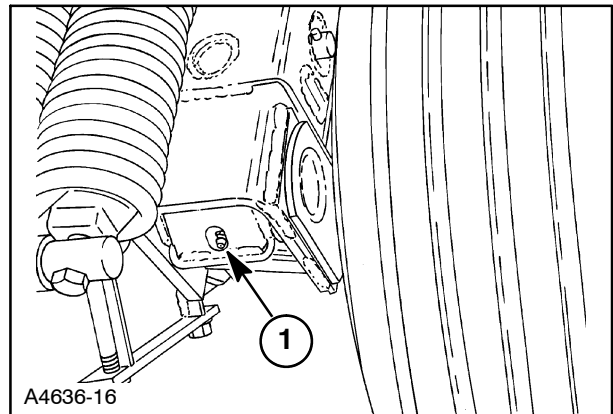

2

**AFTER THE FIRST 50 HOURS OF OPERATION**

**Change the Oil in the Pump Step-up Gearbox**

Place a pan under the gearbox. Remove drain plug, 1, from the bottom of the gearbox. Remove the filler plug, 2, so the oil will drain.

The oil is checked using dipstick, 3. Add oil through plug, 2, until the oil is at the proper level. Use only Case Akcela 135 H EP 80W90.

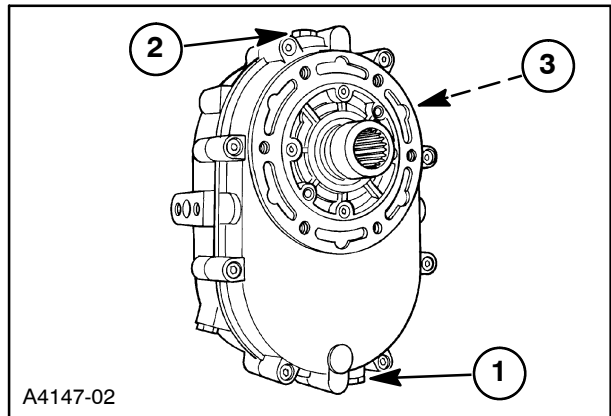

A4147-02

3

**EVERY 50 HOURS OF OPERATION OR WEEKLY**

**Check the Oil in the Pump Step-up Gearbox**

The oil is checked using dipstick, 3. Add oil through plug, 2, until the oil is at the proper level. Use only Case Akcela 135 H EP 80W90 oil to refill the gearbox.

**Oil all hinges and latches.**

**Grease the tongue pivot, 1. (One fitting).**

**Lubricate the tractor PTO shaft with general purpose grease.**

**EVERY 100 HOURS OF OPERATION OR MONTHLY**

**Check Hydrostatic Reservoir Oil Level**

**IMPORTANT:** Lower the header when checking the oil level in the hydrostatic reservoir. The top of the tongue must be level. Clean the area around the filler cap to prevent oil contamination.

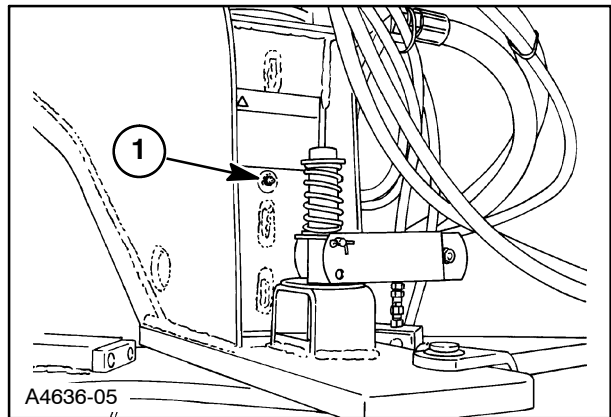

A4636-05

4

**CAUTION**

**Pressurized hydraulic system. Before you replace the hydraulic filter or service the hydraulic system, slowly loosen the hydraulic reservoir fill cap to relieve the air pressure. If you do not follow these instructions, you can be injured.**

SA047

Raise or lower the jackstand to position the top surface of the tongue as level as possible.

Remove the filler cap/dipstick, 1. Replace it finger tight and remove it to check the oil level. The oil level should be between the two marks on the dipstick.

Capacity: 105 L (28 gal.)

Add hydraulic oil to maintain oil at the proper level. Replace the filler cap/dipstick.

**IMPORTANT:** Not all oils are compatible. Be sure to flush all oil from the hydrostatic/hydraulic system before replacing the fluid with a different type.

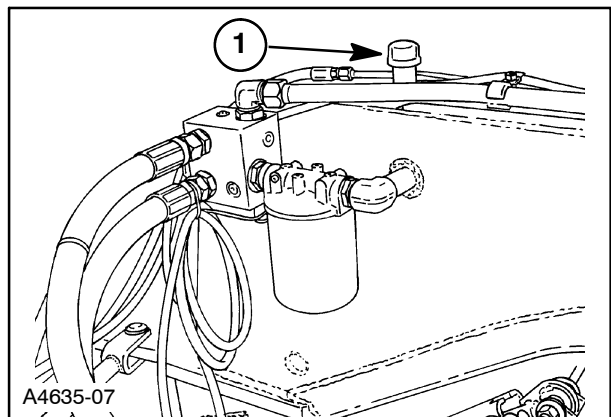

A4635-07

5

**<https://www.ebooklibonline.com>**

Hello dear friend!

Thank you very much for reading.

Enter the link into your browser.

The full manual is available for immediate download.

**<https://www.ebooklibonline.com>**