

# RD162, RDX181 Disc Headers

## Repair Manual

87755425 4/08  
1st Printing



# **RD162, RDX181 REPAIR MANUAL CONTENTS**

- SECTION 00 - GENERAL INFORMATION**
- SECTION 35 - HYDRAULICS**
- SECTION 58 - ATTACHMENTS/HEADERS**
- SECTION 88 - OPTIONAL EQUIPMENT**
- SECTION 90 - DECALS**

**The sections used through out all Caes IH product Repair manuals may not be used for each product. Each Repair manual will be made up of one or several books.**

**The sections listed above are the sections utilized for the RD162 and RDX181 Disc Headers.**

---

# COMPLETE CONTENTS

## SECTION 00 - GENERAL INFORMATION

### Chapter 1 - General Information

#### CONTENTS

Section	Description	Page
	Forward .....	2
	Precautionary Statements .....	3
	Personal Safety .....	3
	Machine Safety .....	3
	Information .....	3
	Safety .....	4
	Precautionary Statements .....	4
	Introduction .....	5
	Product Identification Number (PIN) .....	5
	Jack Assembly .....	6
	Shielding .....	6
	Lights .....	7
	Storing the Header .....	7
	Header (WDX1902, WD1903/RD162, WDX2302, WD2303/RD162, WDX2302, WD2303/RDX181) .....	8
	Installation .....	8
	Removal .....	10
	Electrical Connections .....	13
	Hydraulic Connections .....	13
	Specifications .....	14
	Hardware Torque Values .....	16
	Ecology and the Environment .....	21
	Universal Symbols .....	22

**<https://www.ebooklibonline.com>**

Hello dear friend!

Thank you very much for reading.

Enter the link into your browser.

The full manual is available for immediate download.

**<https://www.ebooklibonline.com>**

---

# SECTION 00 - GENERAL INFORMATION

## Chapter 2 - Adjustments

### CONTENTS

Section	Description	Page
	Swathing .....	2
	Auger Height .....	3
	Auger Paddles .....	4
	Header Floor Pan .....	4
	Conditioner Roll Gap - Rubber Rolls .....	4
	Conditioner Roll Gap/Roll Engagement - Steel Parallel Slats .....	5
	Conditioner Roll Pressure .....	6
	Windrow Shields .....	6
	Conditioner Rolls .....	7
	Unplugging the Conditioner Rolls .....	7
	Roll Timing - Rubber Rolls .....	8
	Adjust Timing .....	8
	Roll Timing - Steel Parallel Slats .....	8
	Reset Timing .....	8
	Conditioner Belt .....	9
	Adjust Belt Tension .....	9
	Cutting Height .....	10
	Tilt Adjustment .....	10
	Header Speed Sensor .....	10
	Adjustments .....	10

---

## SECTION 00 - GENERAL INFORMATION

### Chapter 3 - Lubrication

#### CONTENTS

<b>Section</b>	<b>Description</b>	<b>Page</b>
	Overview .....	2
	General Information .....	2
	Grease Fittings .....	2
	Gearboxes .....	2
	Miscellaneous .....	2
	Lubrication and Service Schedule .....	3
	Lubricated Components .....	4
	Auger Drive Chain .....	4
	Cutter Bar Driveshafts .....	4
	Header Drive Idler Pivot .....	4
	Auger Drive Idler Pivots .....	5
	Conditioner Driveshafts .....	5
	Conditioner Roll Driveshafts .....	5
	Upper Conditioner Roll Arm Pivots .....	6
	Conditioner Roll Pressure Crank .....	6
	Header Drive Gearbox .....	6
	Cutter Bar Modules .....	7
	Conditioner Drive Gearbox .....	9
	Cutter Bar Pivot Points .....	9

## SECTION 00 - GENERAL INFORMATION

### Chapter 4 - Troubleshooting

#### CONTENTS

<b>Section</b>	<b>Description</b>	<b>Page</b>
	Troubleshooting .....	2
	Charts .....	2

---

## SECTION 35 - HYDRAULICS

### Chapter 1 - Hydraulics

#### CONTENTS

Section	Description	Page
	Description of Operation .....	2
	Hydraulic Motors .....	2
	Left Side Motor and Coupling .....	3
	Removal .....	3
	Right Side Motor .....	3
	Removal .....	3
	Field Overhaul .....	4
	Motor .....	4
	Coupling .....	4
	Disassembly .....	4
	Left Side Motor Coupling Housing .....	5
	Assembly .....	5
	Installation .....	5
	Right Side Motor .....	6
	Installation .....	6
	Hydraulic Hoses and Fittings .....	6

## SECTION 35 - HYDRAULICS

### Chapter 2 - Header Drive Motors - RD162

#### CONTENTS

Section	Description	Page
	Overview .....	2
	Special Tools .....	2
	Specifications .....	2
	Fixed Displacement Motors - After PIN 1130000 .....	2
	Lubrication .....	2
	Fixed Displacement Motor .....	3
	Overhaul .....	4
	Hydraulic Motor .....	4
	Disassembly .....	4
	Inspection .....	6
	Assembly .....	7
	Hydraulic Hoses and Fittings .....	10

---

## SECTION 35 - HYDRAULICS

### Chapter 3 - Header Drive Motors - RDX181

#### CONTENTS

Section	Description	Page
	Overview .....	2
	Special Tools .....	2
	Specifications .....	2
	Fixed Displacement Motors .....	2
	Lubrication .....	2
	Overhaul .....	4
	Hydraulic Motor .....	4
	Removal .....	4
	Inspection .....	4
	Installation .....	4
	Back Plate .....	5
	Disassembly .....	5
	Inspection .....	6
	Assembly .....	7
	Main Shaft .....	9
	Removal .....	9
	Inspection .....	13
	Assembly .....	14
	Troubleshooting .....	19

---

## SECTION 58 - ATTACHMENTS/HEADERS

### Chapter 1 - Bevel Gearbox Header Drive

#### CONTENTS

<b>Section</b>	<b>Description</b>	<b>Page</b>
	Introduction .....	2
	Overhaul .....	2
	Bevel Gearbox .....	2
	Disassembly .....	2
	Upper Bearing .....	7
	Removal - (RD162), RDX181 .....	7
	Installation .....	8
	Lower Bearing - (RD162), RDX181 .....	9
	Removal .....	9
	Installation .....	9
	Vertical Shaft (Gearbox) - (RD162), RDX181 .....	10
	Assembly .....	10
	Side Shaft .....	11
	Assembly .....	11
	Gearbox .....	12
	Installation .....	12

---

# SECTION 58 - ATTACHMENTS/HEADERS

## Chapter 2 - Cutter Bar

### CONTENTS

Section	Description	Page
	Introduction .....	2
	Cutter Bar .....	2
	Cutter Bar Analysis .....	5
	Inspection/Failure .....	5
	Top Cap .....	7
	Removal .....	7
	Inspection .....	8
	Installation .....	9
	Cutter Bar .....	10
	Removal - WDX1902 - WD1903/RD162, WDX2302 - WDX2303/RDX181, WDX2302 - WD2303/RD162 .....	10
	Installation .....	12
	Cutter Bar Bayonet Bushing .....	13
	Removal .....	13
	Inspection .....	14
	Installation .....	14
	Cutter Bar .....	15
	Disassembly .....	15
	Assembly .....	15
	Disc Module .....	19
	Disassembly .....	19
	Assembly .....	21

---

## SECTION 58 - ATTACHMENTS/HEADERS

### Chapter 3 - Cutter Bar Drive

#### CONTENTS

Section	Description	Page
	Overhaul .....	2
	Cutter Bar Driveshaft .....	2
	Disassembly .....	2
	Reassembly .....	4

## SECTION 58 - ATTACHMENTS/HEADERS

### Chapter 4 - Auger and Auger Drive

#### CONTENTS

Section	Description	Page
	Introduction .....	2
	Auger and Auger Drive .....	2
	Removal .....	2
	Installation .....	6

## SECTION 58 - ATTACHMENTS/HEADERS

### Chapter 5 - Conditioner Drive Gearbox

#### CONTENTS

Section	Description	Page
	Conditioner Drive Gearbox .....	2
	Removal .....	2
	Disassembly .....	3
	Inspection .....	4
	Reassembly .....	5
	Installation .....	7

---

## SECTION 58 - ATTACHMENTS/HEADERS

### Chapter 6 - Conditioner Roll Drive

#### CONTENTS

Section	Description	Page
	Conditioner Roll Drive Shaft .....	2
	Removal .....	2
	Disassembly .....	2
	Reassembly .....	4
	Installation .....	5

## SECTION 58 - ATTACHMENTS/HEADERS

### Chapter 7 - Conditioner Rolls

#### CONTENTS

Section	Description	Page
	Lower Rubber or Steel Conditioner Roll RD162/RDX181 .....	2
	Removal .....	2
	Installation .....	4
	Upper Rubber or Steel Conditioner Roll RD162/RDX181 .....	6
	Removal .....	6
	Installation .....	8
	Rubber Conditioning Rolls .....	10
	Steel Parallel Slats .....	10
	Timing and Gap for Steel .....	10
	Conditioner Assembly WD1903/RD162, WD2303/RD162, WD2303/RDX181 .....	11
	Removal .....	11
	Installation .....	15
	Lower Conditioner Roll WD1903/RD162, WD2303/RD162, WD2303/RDX181 .....	17
	Removal .....	17
	Upper Conditioner Roll WD1903/RD162, WD2303/RD162, WD2303/RDX181 .....	19
	Removal .....	19

---

## SECTION 58 - ATTACHMENTS/HEADERS

### Chapter 8 - Conditioner Roll Tension System

#### CONTENTS

Section	Description	Page
	Overhaul .....	2
	Conditioner Roll Tension System .....	2
	Removal .....	2
	Right Side Torsion Arm and Bar .....	2
	Disassembly .....	2
	Left Side Torsion Arm and Bar .....	4
	Disassembly .....	4
	Left Side Torsion Arm and Bar .....	7
	Reassembly .....	7
	Right Side Torsion Arm and Bar .....	9
	Assembly .....	9

---

## SECTION 88 - OPTIONAL EQUIPMENT

### Chapter 1 - Optional Equipment

#### CONTENTS

<b>Section</b>	<b>Description</b>	<b>Page</b>
	Optional Equipment .....	2
	Field Installed Options .....	2
	High Stubble Kit .....	2
	Header Closure Kit .....	3
	Steel Slatted Conditioning Rolls .....	3
	Gauge Wheel Kit .....	4
	Rolling Crop Dividers .....	4
	Push Bar and Dividers .....	4
	Replacement Disc Knives .....	5

## SECTION 90 - DECALS

### Chapter 1 - Decals

#### CONTENTS

<b>Section</b>	<b>Description</b>	<b>Page</b>
	Safety Decals .....	2



**SECTION 00 - GENERAL INFORMATION**

**Chapter 1 - General Information**

**CONTENTS**

<b>Section</b>	<b>Description</b>	<b>Page</b>
	Forward .....	2
	Precautionary Statements .....	3
	Personal Safety .....	3
	Machine Safety .....	3
	Information .....	3
	Safety .....	4
	Precautionary Statements .....	4
	Introduction .....	5
	Product Identification Number (PIN) .....	5
	Jack Assembly .....	6
	Shielding .....	6
	Lights .....	7
	Storing the Header .....	7
	Header (WDX1902, WD1903/RD162, WDX2302, WD2303/RD162, WDX2302, WD2303/RDX181) .....	8
	Installation .....	8
	Removal .....	10
	Electrical Connections .....	13
	Hydraulic Connections .....	13
	Specifications .....	14
	Hardware Torque Values .....	16
	Ecology and the Environment .....	21
	Universal Symbols .....	22

## **FORWARD**

Appropriate service methods and correct repair procedures are essential for the safe, reliable operation of all equipment, as well as the personal safety of the individual performing the repair.

This Repair Manual provides troubleshooting and overhaul instructions using recommended procedures and equipment. Following these instructions will ensure the safe, efficient, and timely completion of the service or repair.

The manual is divided into sections which are subdivided into chapters. Each chapter contains information on general operating principals, detailed inspection, overhaul and, where applicable, specific troubleshooting, special tools, and specifications.

Any reference in this manual to right, left, rear, front, top, or bottom is determined by standing behind the machine and looking in the direction of travel.

All data and illustrations in this manual are subject to variations in build specification. This information was correct at the time of issue, but Case IH policy is one of continuous improvement, and the right to change specifications, equipment, or design at any time, without notice, is reserved.

# PRECAUTIONARY STATEMENTS

## PERSONAL SAFETY

Throughout this manual and on machine decals, you will find precautionary statements (“**DANGER**”, “**WARNING**”, and “**CAUTION**”) followed by specific instructions. These precautions are intended for the personal safety of you and those working with you. Please take the time to read them.



**DANGER**



This word “**DANGER**” indicates an immediate hazardous situation that, if not avoided, will result in death or serious injury. The color associated with Danger is RED.

---



**WARNING**



This word “**WARNING**” indicates a potentially hazardous situation that, if not avoided, could result in death or serious injury. The color associated with Warning is ORANGE.

---



**CAUTION**



This word “**CAUTION**” indicates a potentially hazardous situation that, if not avoided, may result in minor or moderate injury. It may also be used to alert against unsafe practices. The color associated with Caution is YELLOW.

---

**FAILURE TO FOLLOW THE “DANGER”, “WARNING”, AND “CAUTION” INSTRUCTIONS MAY RESULT IN DEATH OR SERIOUS BODILY INJURY.**

## MACHINE SAFETY

The precautionary statement (“**IMPORTANT**”) is followed by specific instructions. This statement is intended for machine safety.

**IMPORTANT:** *The word “IMPORTANT” is used to inform the reader of something he needs to know to prevent minor machine damage if a certain procedure is not followed.*

## INFORMATION

**NOTE:** *Instructions used to identify and present supplementary information.*

# SAFETY

## PRECAUTIONARY STATEMENTS

A careful operator is the best operator. Most accidents can be avoided by observing certain precautions. To help prevent accidents, read the following precautions before operating this equipment. Equipment should be operated only by those who are responsible and instructed to do so.

Carefully review the procedures given in this manual with all operators. It is important that all operators be familiar with and follow safety precautions.

1. **Do not operate the disc auger header without all the cutter bar shields down, cover skirts installed and is good condition, and cover skirts snapped together. Immediately replace any skirt that is torn or has a hole in it.**
2. **Header locks are built into the header lift system to lock the header in the raised position. Lock the header on both sides before working under a raised header.**
3. **Use the amber flashing safety lights and road lights when driving the self-propelled windrower and header on the highway. Be sure to use the road lights, not the work lights, because the rear work lights could be mistaken for an oncoming vehicle.**
4. **Instruct inexperienced operators to read the operator's manual, safety signs, and become familiar with the handling of the unit which the disc auger header is attached. Operate the unit in uncongested areas where there is no likelihood of personal injury or property damage.**
5. **Never make any adjustments or attempt to work on the unit with the engine running. Disengage the header drive, lower the header to the ground, or lock it in the transport position, shut off the engine, and engage the parking brake before attempting any adjustments or trying to work on the header.**
6. **Tilt the cutter bar back in fields where stones and foreign objects are present, to raise the cutting knives, minimize debris deflected from the knives and reduce knife damage.**
7. **STAND CLEAR! Rotating elements may cause serious bodily injury.**
8. **Do not attempt to remove material from the disc auger header while it is in operation. Shut the windrower off and allow the rotating discs to stop before leaving the windrower cab.**
9. **Always operate the disc auger header with the covers and shields in place. Do not lean against or stand on the covers or shields.**
10. **Do not attempt to adjust the lift linkage with a header attached. Header will drop suddenly if clevis pin is driven out, causing header damage and/or personal injury.**
11. **Observe the following precautions before adjusting or lubricating the header.**
  - **Disengage the header drive.**
  - **Lower the header to the ground, or raise the header and engage the header locks.**
  - **Stop the engine and engage the parking brake before leaving the cab.**
  - **Reinstall and close all shielding before operating the unit.**
12. **Do not attempt to clean, lubricate, or adjust the machine while it is running.**
13. **Replace damaged knives, knife hardware or discs immediately to prevent an accident.**
14. **The bottom leading edge of worn discs can become very sharp. Wear gloves to prevent injury.**

## INTRODUCTION

The RD162 disc auger header is a disc mower-conditioner designed to be used with the WDX1902, WDX2302, WD1903, and the WD2303 self-propelled windrowers. The RDX181 disc auger header is designed to be used only with the WDX2302 and WD2303. The two operate together as an integral unit. The valves and cylinders for lifting and tilting the header are mounted on the windrower, as are all the hydraulic controls.

The RD162 header contains 12 disc mowing modules, while the RDX181 header contains 14 disc mowing modules. An auger feeds the crop to two molded rubber inter-meshing chevron conditioner rolls. A hydraulic pump on the windrower supplies all power for the header.

The windrower controls the speed of the header in either automatic or manual mode. In the automatic mode, the speed is held constant regardless of the speed of the windrower. In the manual mode, the speed varies with the windrower engine speed. The mode is set from the windrower cab.

**NOTE:** On this equipment, left and right are determined by standing behind the unit, looking in the direction of travel.

## PRODUCT IDENTIFICATION NUMBER (PIN)

The PIN plate, 1, for the disc mower-conditioner is located at the back on the left side of the frame.

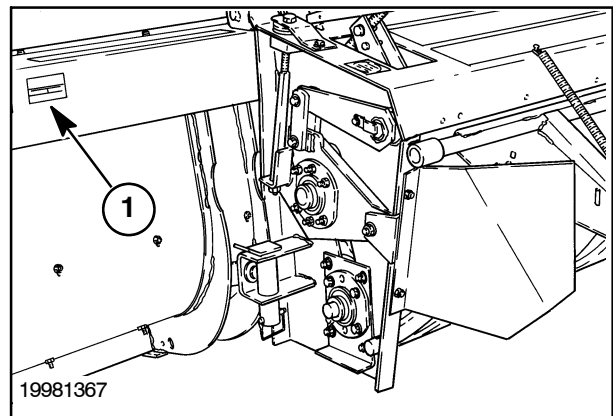

1

### JACK ASSEMBLY

There are two jack stands built into the header, 1, one on each side of the unit.

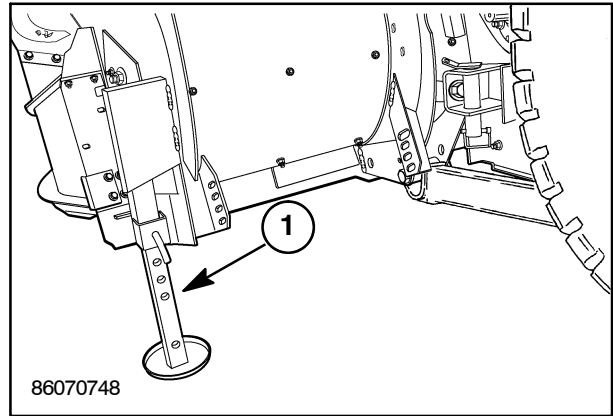

2

### SHIELDING

**NOTE:** Before raising either of the front shields, unhook the cutter bar shield skirt spring snaps, 1, at the skirt overlaps. Be sure that the skirts are reattached before using the header again.

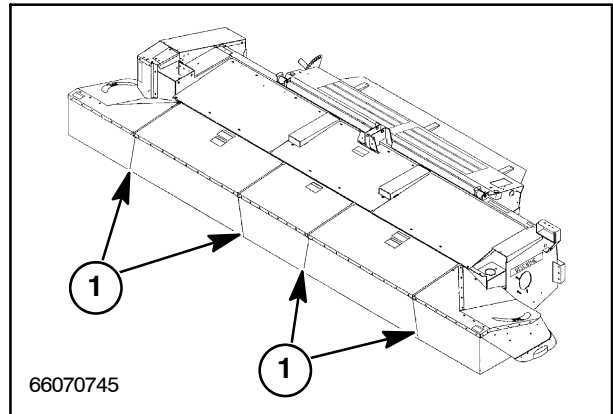

3

When raised, the front shields are held in place by a lever, 1. The lever automatically springs into the lock as the shield is raised. To lower the shield, release the lever by pushing it to the side.

— **⚠ WARNING ⚠** —

**Close shields prior to operating the machine. Failure to comply could result in death or serious injury.**

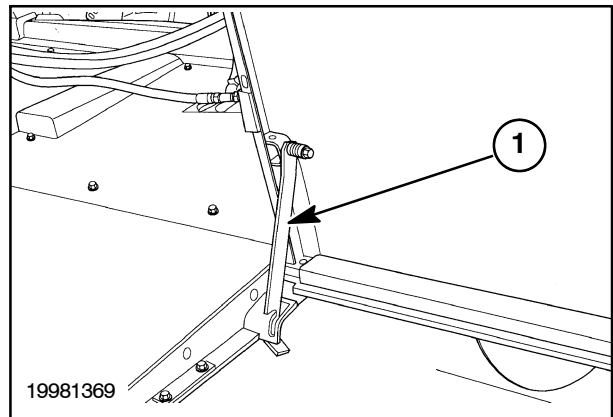

4



**Suggest:**

**For more complete manuals. Please go to the home page.**

**<https://www.ebooklibonline.com>**

**If the above button click is invalid. Please download this document first, and then click the above link to download the complete manual.**

**Thank you so much for reading**

The right side shield can be lifted by releasing two rubber straps, 1, on the front and rear of the shield, and pivoting the shield upward. Lift the shield part way and remove the latch rod, 2, from the slot in the shield. Raise the shield fully and hook the rod into the slot in the top of the shield to support the shield.

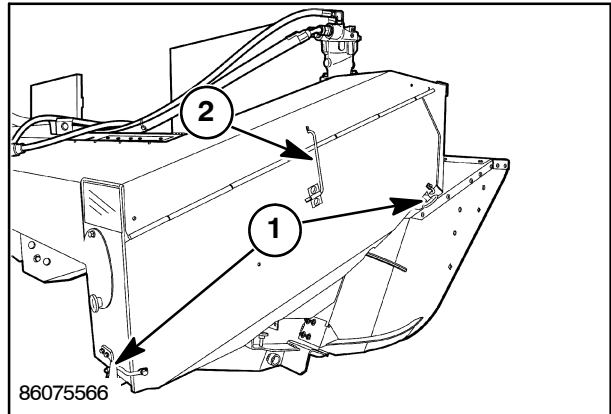

5

## LIGHTS

There are two warning lights on the header, 1; one on each outboard side. These act as hazard flashers and turn signal lights. They are operated from the cab of the windrower.

## STORING THE HEADER

When preparing the header for storage:

1. Clean the header thoroughly. Remove any build-up of debris and any wrapped material from the cutter bar and the conditioner rolls.
2. Lubricate the header.
3. Drain the oil from all gearboxes and refill with clean oil of the correct specification to the correct level. Run the header for a few minutes.
4. Inspect for worn or broken parts. Replace with genuine factory parts.
5. Relieve roll pressure.
6. Remove tension from the roll drive belt.
7. Clean rusted or abraded areas and touch up with factory paint. Spray cans are available from your authorized dealer.
8. Store the header where it is not exposed to weather.

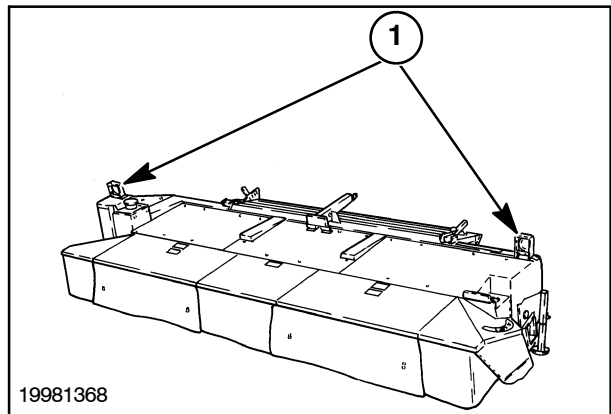

6

**HEADER**

(WDX1902, WD1903/RD162, WDX2302,  
WD2303/RD162, WDX2302,  
WD2303/RDX181)

**Installation**

1. Lower the lift arms as much as possible. Apply a liberal coating of multi-purpose grease to the lift cups, 1.
2. Drive the tractor up to the header so the lifting cups on the lift arms are directly below the lift bushings, 2. Raise the lift arms until they are firmly in place. Raise the jack stands into the storage position.

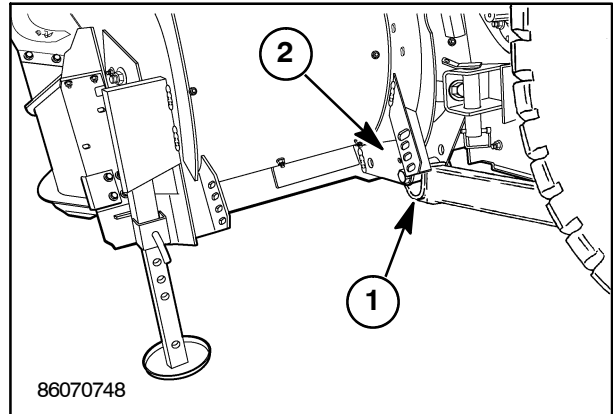

3. Remove the pin holding the header tilt cylinder in the storage position and connect it to the header using a clevis pin. On the RDX181 header the cylinder only has one hole to connect to on the header. When the header tilt channel is installed in the rearward holes, 1, this provides a cutting range of 1-1/2" to 3". When installed in the forward holes, 2, the cutting range is 1" to 2-1/4". The forward holes on the tilt channel should be used for most crops.

**IMPORTANT:** Do not use this hole, 3, to store a pin while the header is attached. Damage to the tilt cylinder and base unit will result.

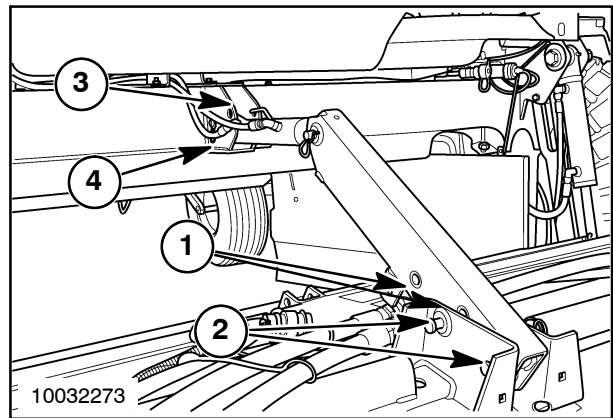

4. Retract the tilt cylinder or raise the header to cause the sliding link to move to the operating position. Install the retaining pin, 4. Connect the wire harness for the header speed sensor and flashers.

**<https://www.ebooklibonline.com>**

Hello dear friend!

Thank you very much for reading.

Enter the link into your browser.

The full manual is available for immediate download.

**<https://www.ebooklibonline.com>**